

SPIRIT II

E-210 GBS · S-210 GBS · E-310 GBS



Gratis download | Kostenloser download
Téléchargement gratuit | Download gratuito

MONTAGE-INSTRUCTIES

MONTAGEANLEITUNG

ENSEMBLE GUIDE

GUIDA ALL'ASSEMBLAGGIO

40810

110119

NL / DE / FR / IT



NL

- △ Monteer de grill op een vlak, horizontaal en zacht oppervlak.
- △ Gebruik geen elektrisch gereedschap bij de montage.
- △ Er zijn twee mensen nodig voor de montage.
- △ Er kunnen uiterlijke verschillen bestaan tussen de illustraties en het aangeschafte model.

DE

- △ Den Grill auf einer flachen, ebenen und weichen Fläche aufbauen.
- △ Keine Elektrowerkzeuge bei der Montage verwenden.
- △ Die Montage muss von 2 Personen durchgeführt werden.
- △ Das erworbene Grillmodell kann geringfügig von der Darstellung abweichen.

FR

- △ Montez le barbecue sur une surface plane, horizontale et souple.
- △ N'utilisez pas d'outils électriques pour l'assemblage.
- △ L'assemblage doit être effectué par deux personnes.
- △ Le modèle acheté peut différer visuellement des illustrations.

IT

- △ Assemblare il barbecue su una superficie piana, livellata e morbida.
- △ Non utilizzare utensili elettrici per l'assemblaggio.
- △ Due persone sono necessarie per l'assemblaggio.
- △ Differenze visive potrebbero essere presenti tra le illustrazioni e il modello acquistato.

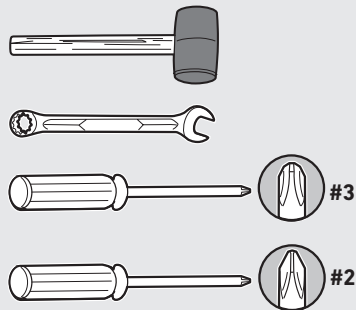
BENODIGD GEREEDSCHAP:**ERFORDERLICHES WERKZEUG:****OUTILS NÉCESSAIRES :****ATTREZZI NECESSARI:**

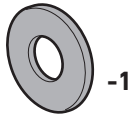
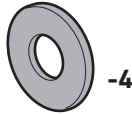
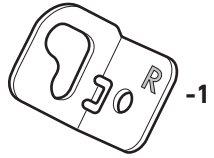
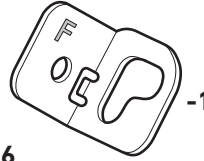
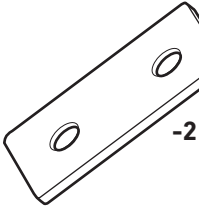
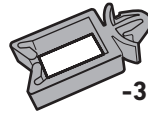
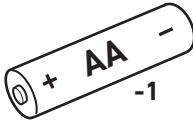
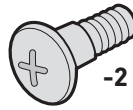
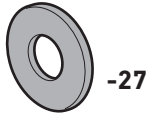

- Extra onderdelen
- Zusätzlich benötigte Teile
- Vis supplémentaire
- Minuteria aggiuntiva

210

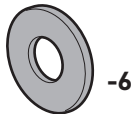

- Alleen modellen: 210
- Nur folgende modelle: 210
- Modèles seulement: 210
- Solo modelli: 210

310

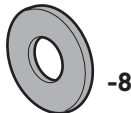

- Alleen modellen: 310
- Nur folgende modelle: 310
- Modèles seulement: 310
- Solo modelli: 310

1

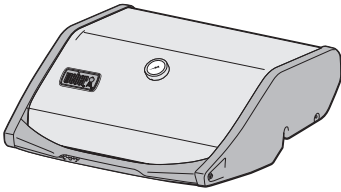

1

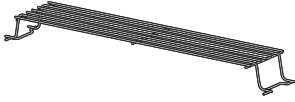

2

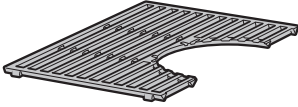

1



1

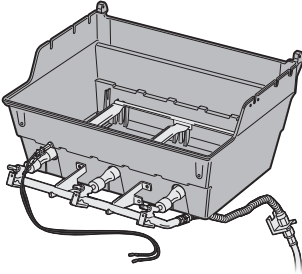

1

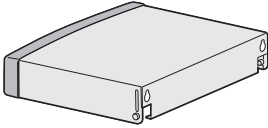

1

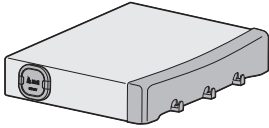

1

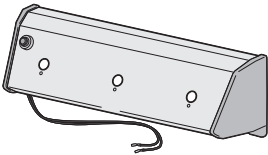

1

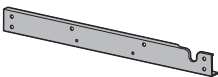

1

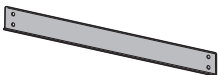

1

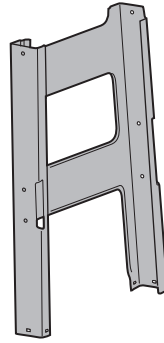

1

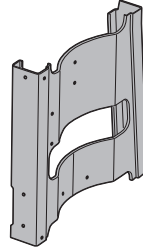

1

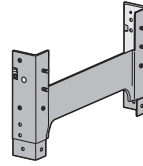

1

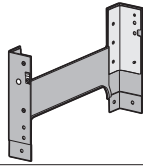

1

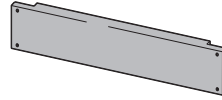

1

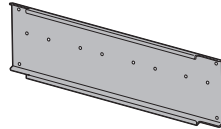

1



1

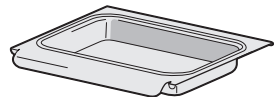

1

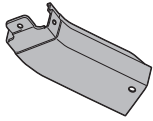

1

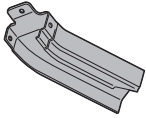

1



2



2



1

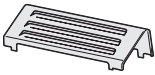

1



1

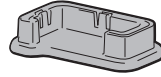

1

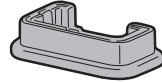

1

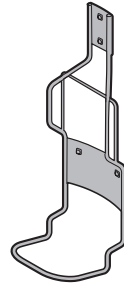

210

3

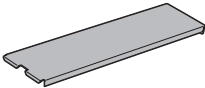

2



3

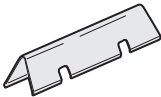

310

4

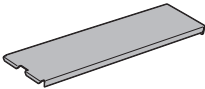

3



5

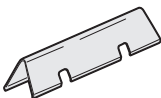

1



- Download de gratis BILT-app voor stapsgewijze 3D-instructies.
- Lade die kostenlose BILT-App herunter, um dir eine Schritt-für-Schritt-Anleitung in 3-D anzeigen zu lassen.
- Téléchargez l'appli gratuite BILT qui vous expliquera le montage étape par étape en 3D.
- Scaricare l'app BILT gratuita per istruzioni 3D passo passo.

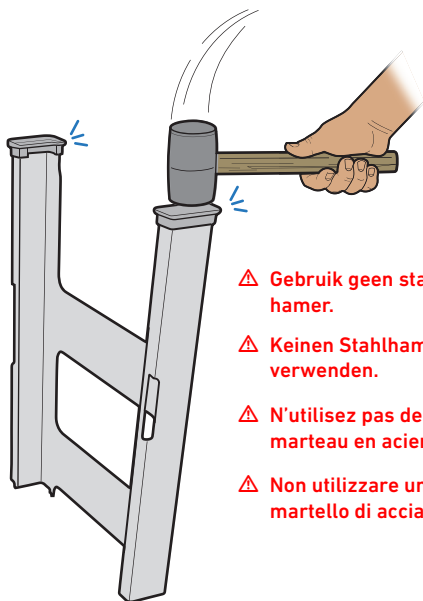
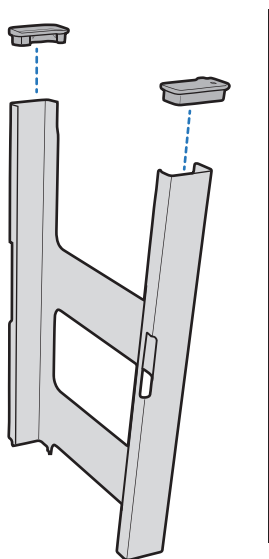

2

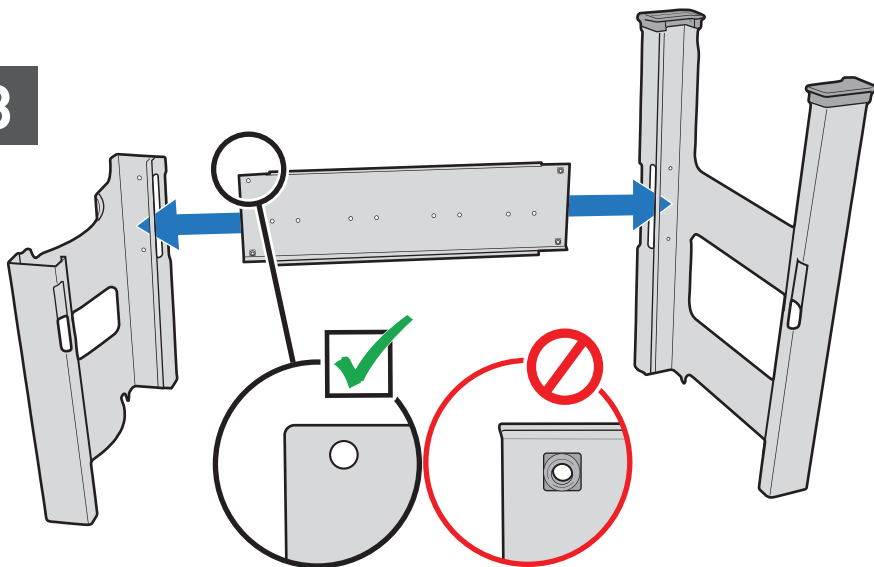

- ⚠ Gebruik geen stalen hamer.
- ⚠ Keinen Stahlhammer verwenden.
- ⚠ N'utilisez pas de marteau en acier.
- ⚠ Non utilizzare un martello di acciaio.

3

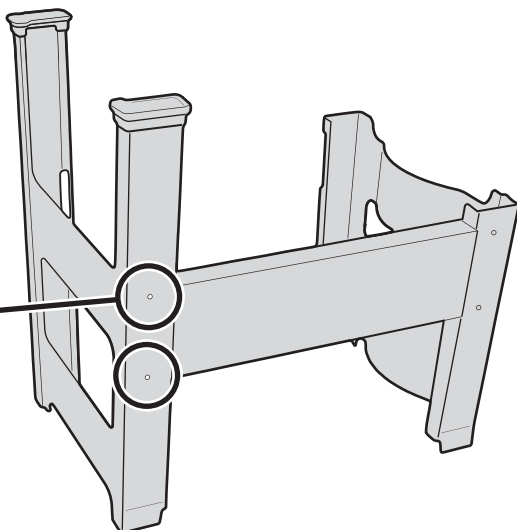
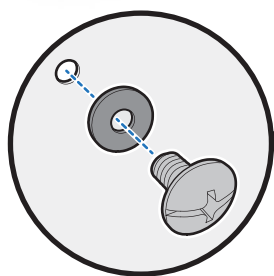
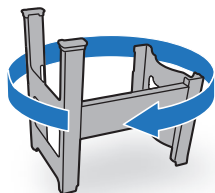
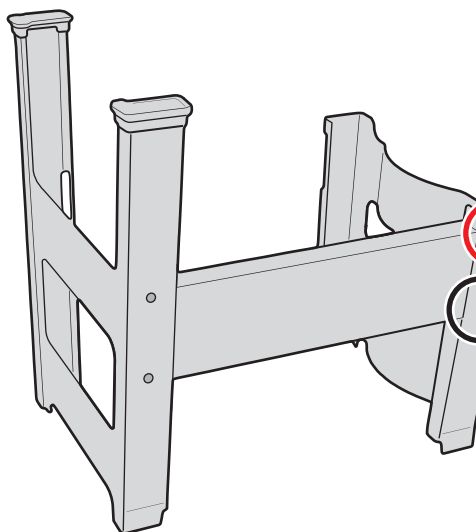

42- 2- **5**1- 1- 

⚠ GEEN schroef en sluitring.
 ⚠ KEINE Schrauben und Unterlegscheiben.
 ⚠ N'utilisez PAS de vis ou rondelle ici.
 ⚠ NON necessita di vite e rondella.

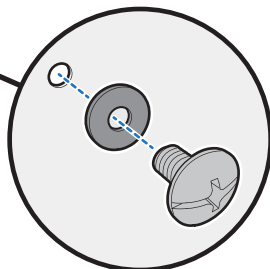

6

3-



3-

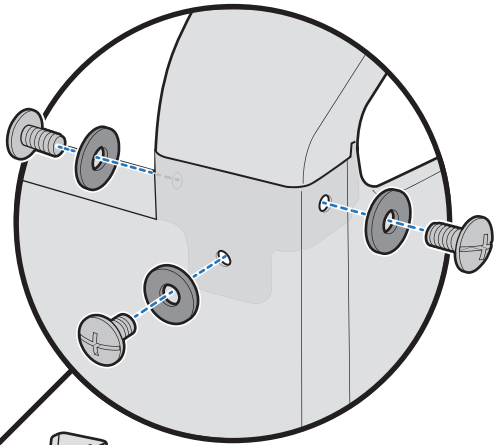
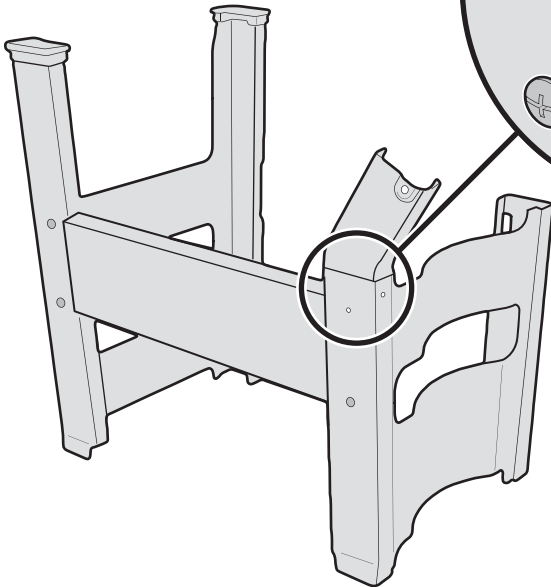
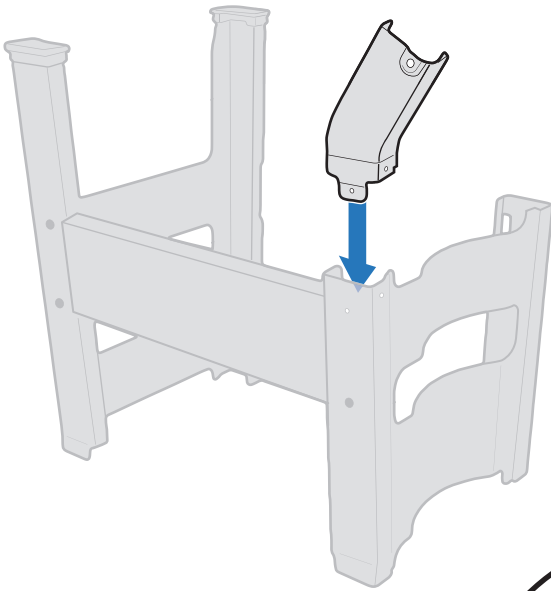

7

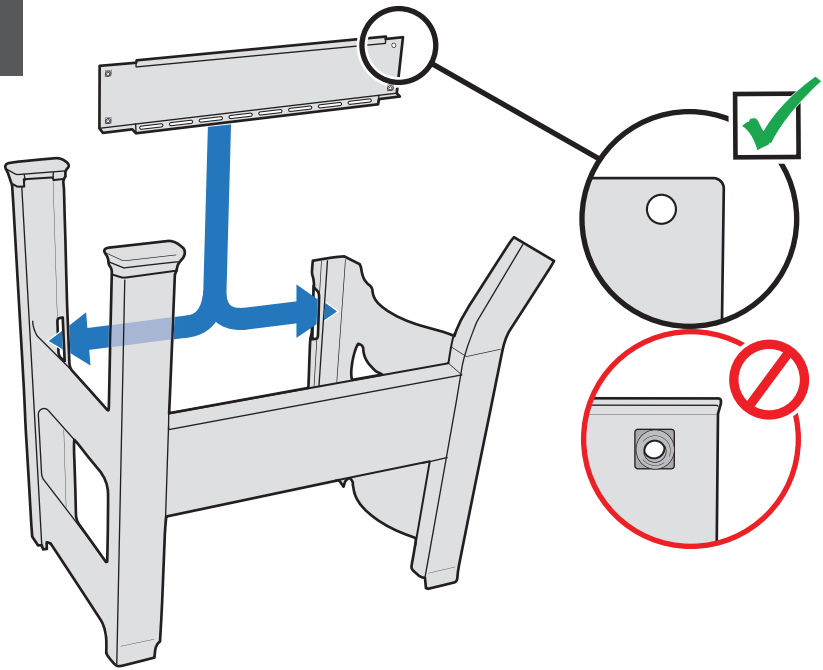

8

2- 

2- 

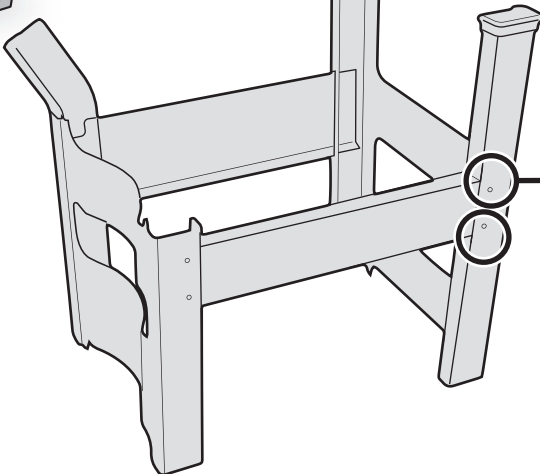
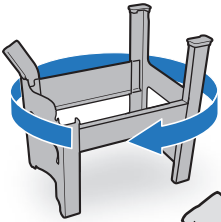

9

1- 

1- 



- ⚠ GEEN schroef en sluitring.
- ⚠ KEINE Schrauben und Unterlegscheiben.
- ⚠ N'utilisez PAS de vis ou rondelle ici.
- ⚠ NON necessita di vite e rondella.

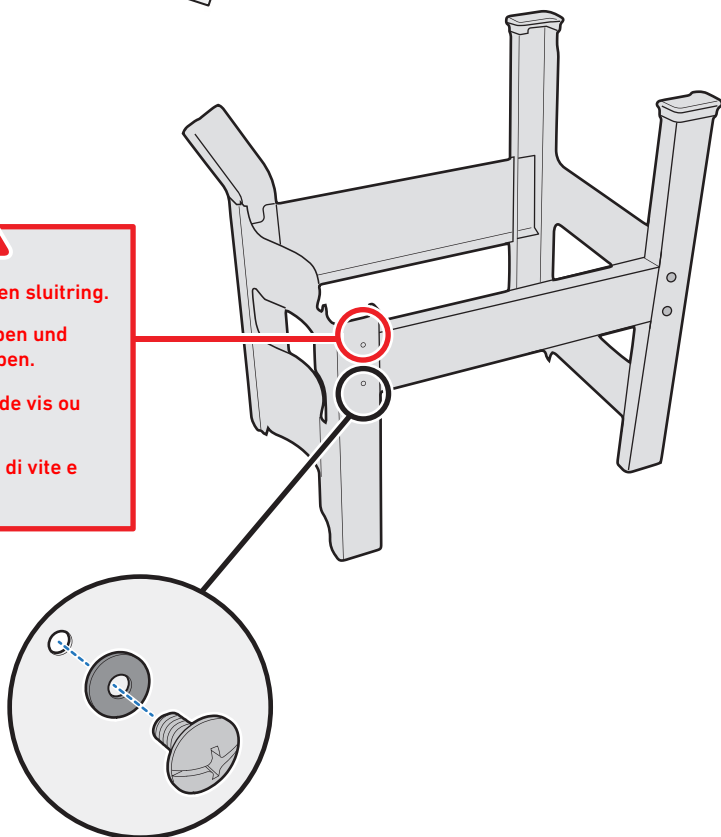

10

3- 

3- 

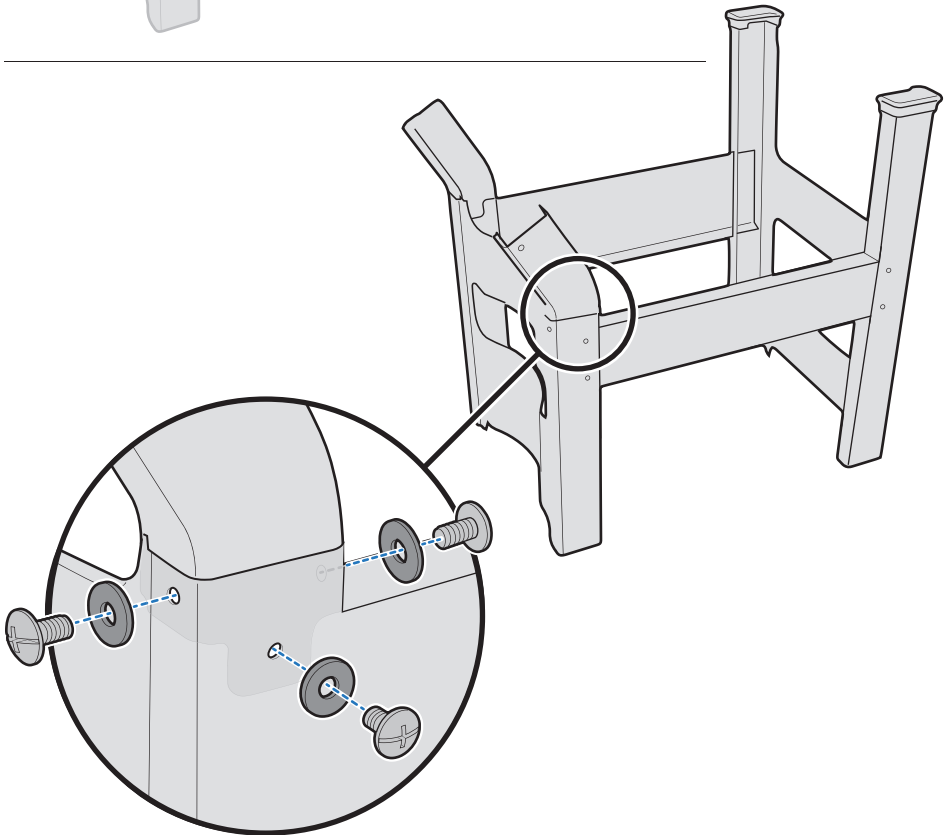
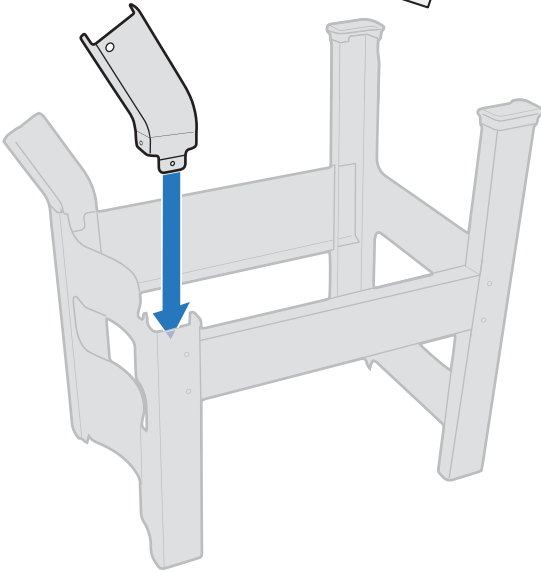

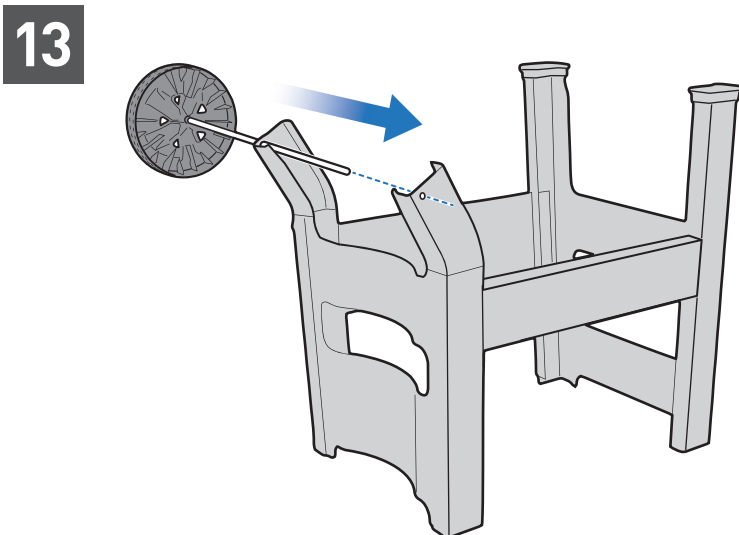
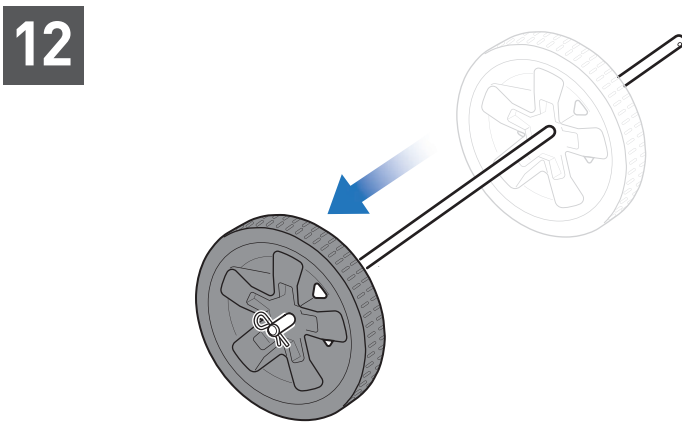
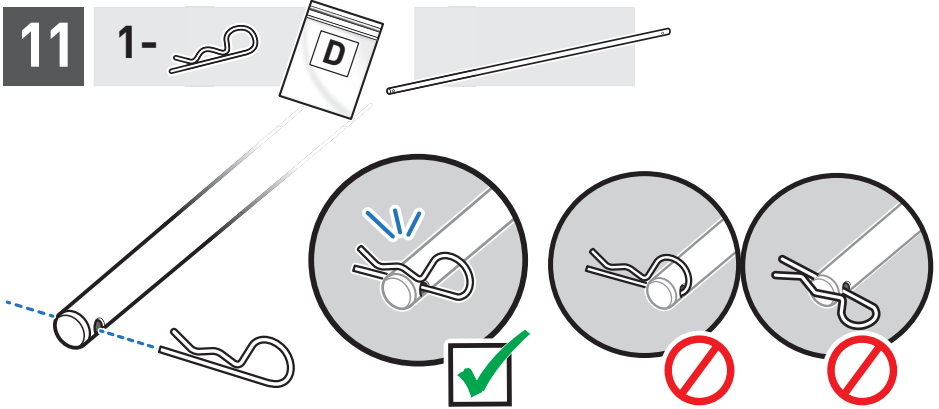

14

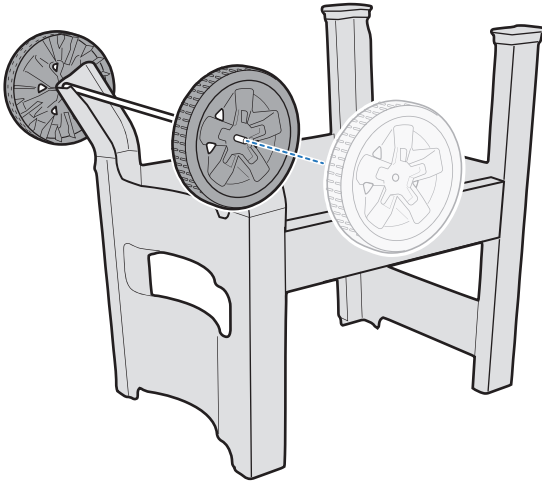

15

1-

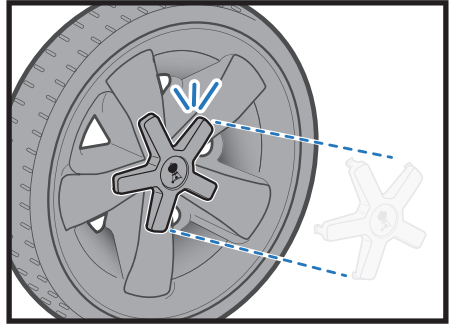
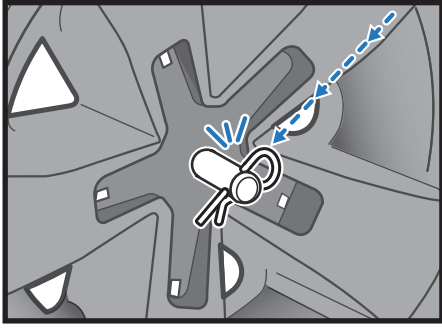
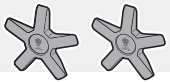

16

210

3-

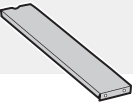

310

4-

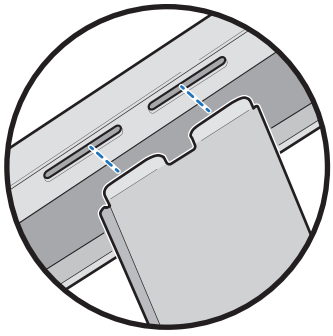
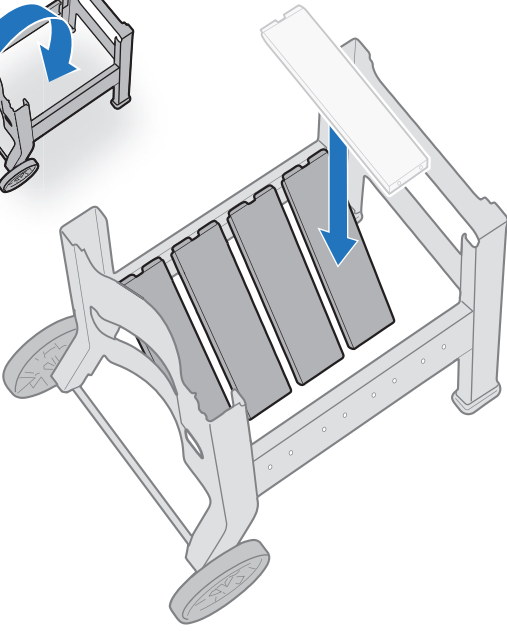
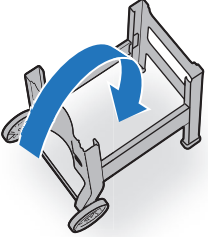
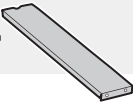

17

210

6-



6-



310

8-



8-

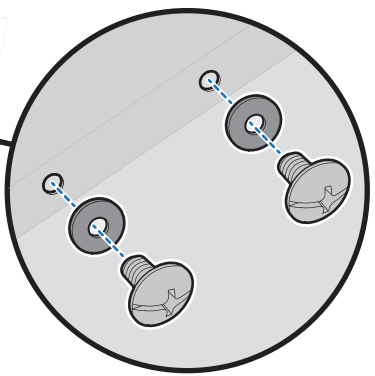
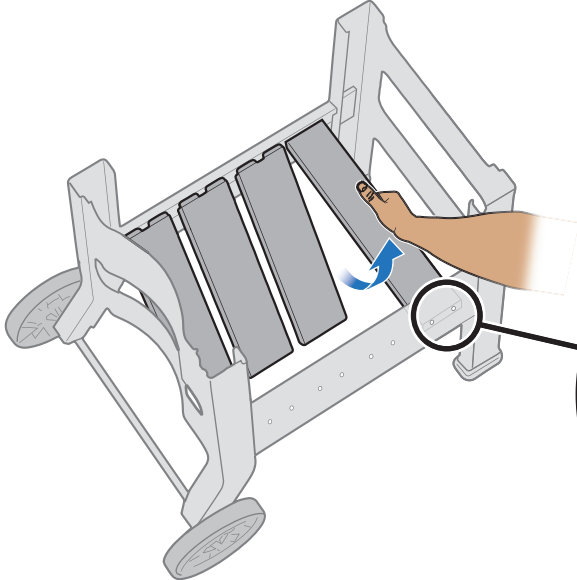

188- 8- 

- ⚠ De wielen moeten aan de RECHTERKANT staan.
- ⚠ Die Räder müssen sich RECHTS befinden.
- ⚠ Les roues doivent se trouver à DROITE.
- ⚠ Le ruote devono essere sulla DESTRA.

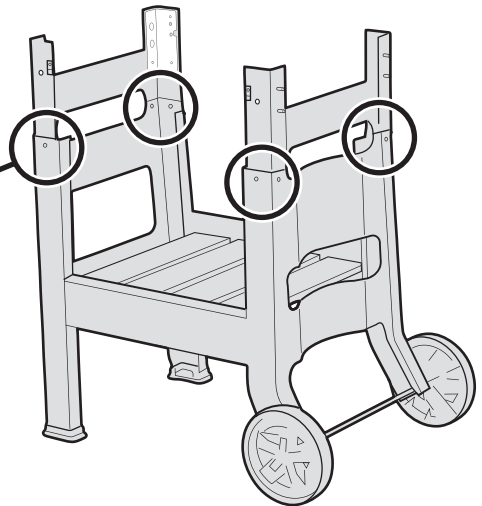
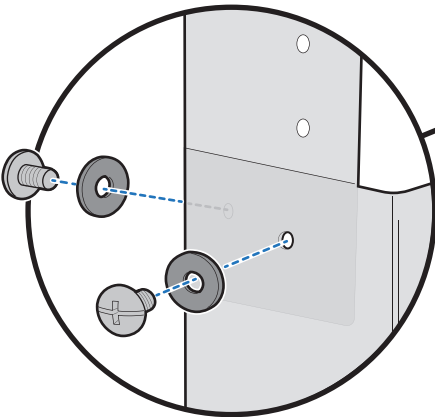
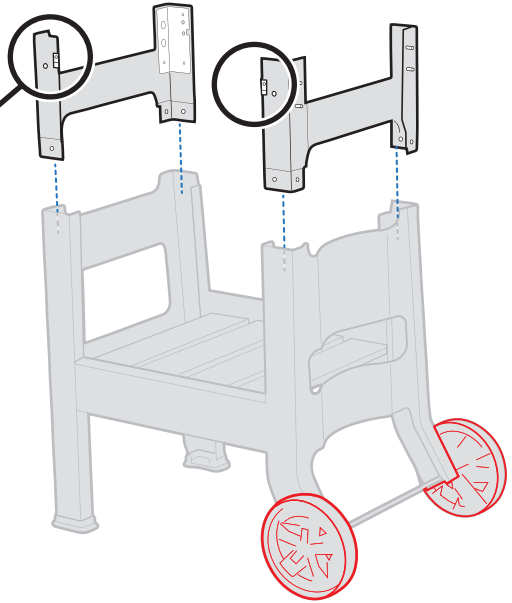
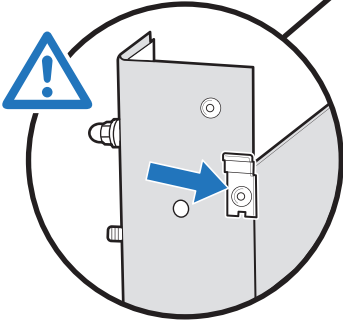
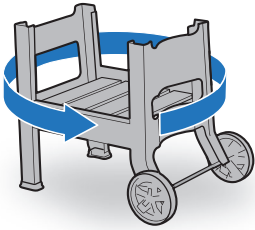

19

2-

2-

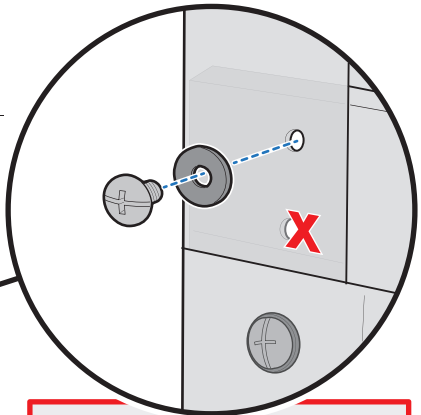
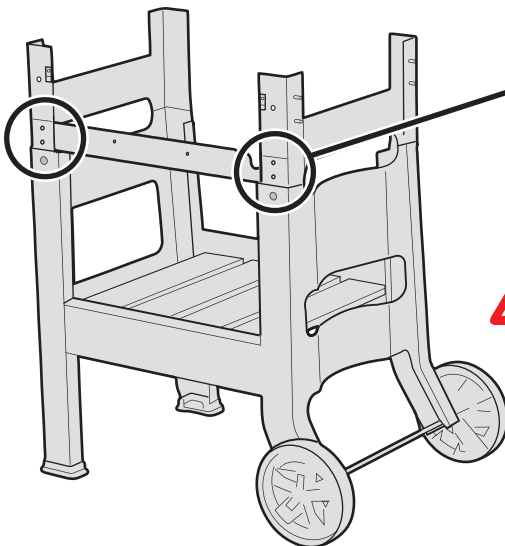
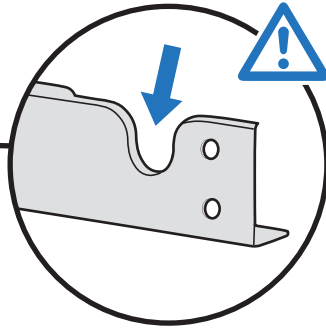
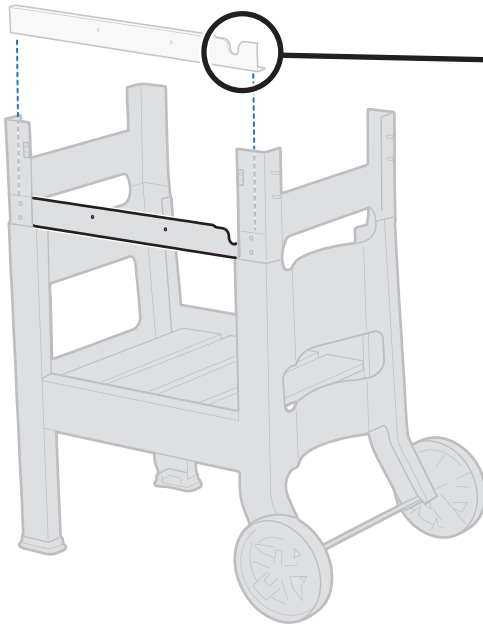

⚠ Monteer ALLEEN de bovenste schroef en sluitring.

⚠ NUR obere Schraube und Unterlegscheibe montieren.

⚠ Installez UNIQUEMENT la vis supérieure et une rondelle.

⚠ Montare SOLO la vite superiore e la rondella.

20

4-  4- 



a.

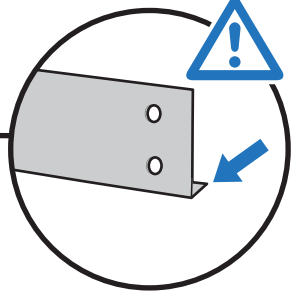
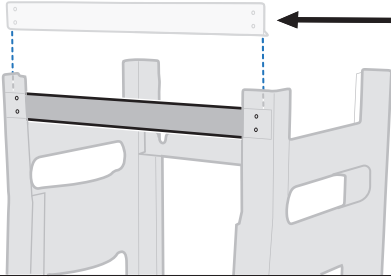

b.

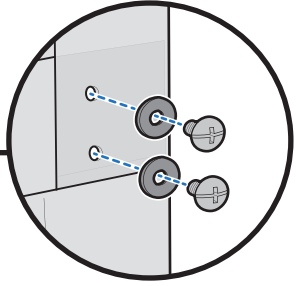
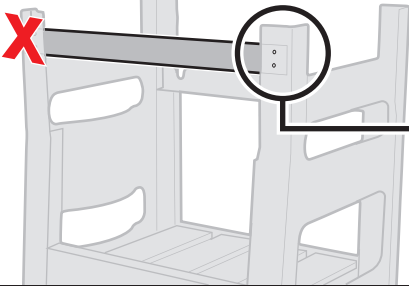

c.

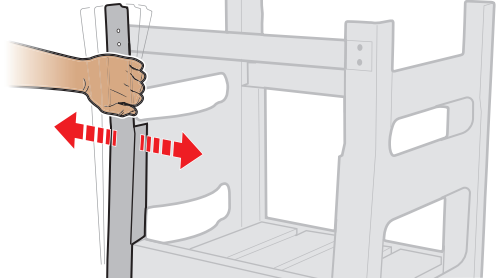

d.

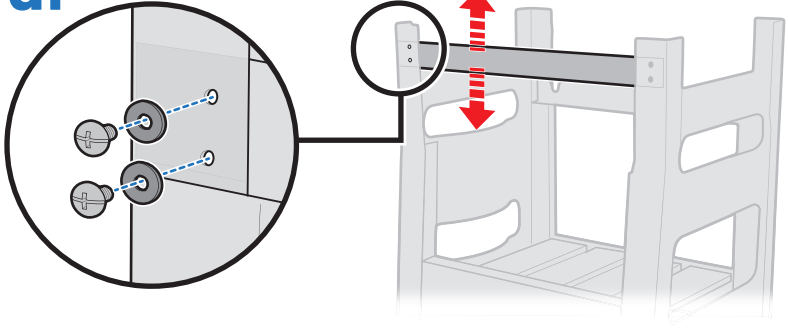

21

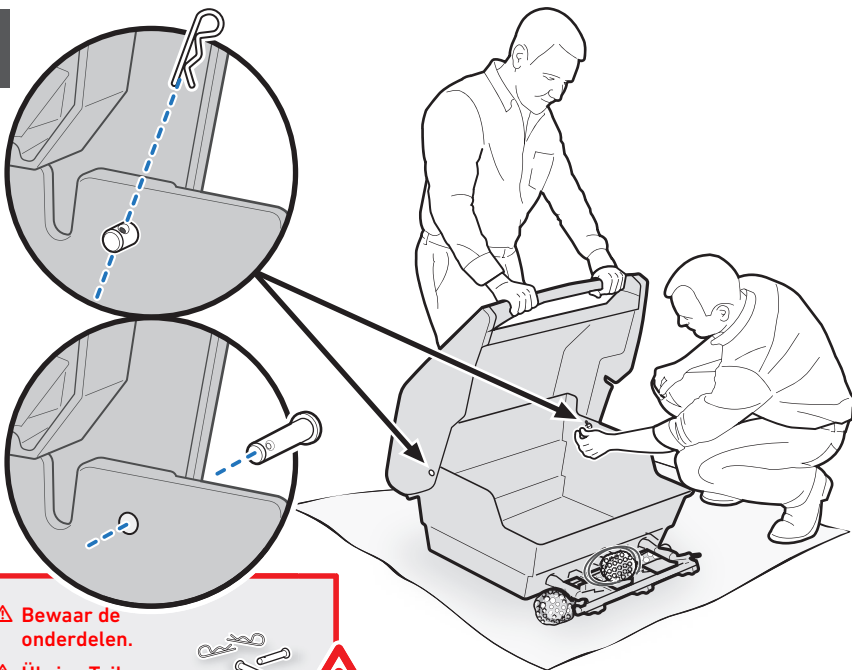

⚠ Bewaar de onderdelen.

⚠ Übrige Teile aufbewahren.

⚠ Conservez la quincaillerie restante.

⚠ Conservare la minuteria.

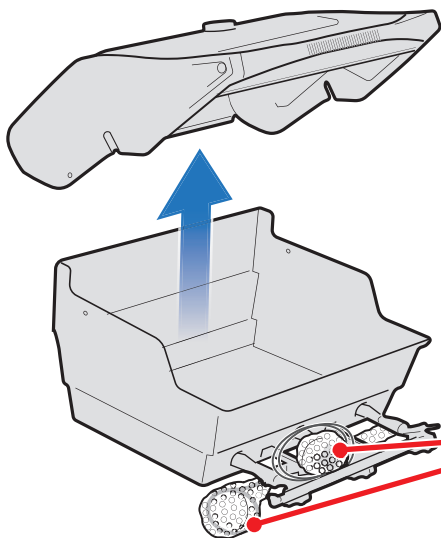

⚠ Verwijder al het verpakkingsmateriaal.

⚠ Sämtliches Verpackungsmaterial entfernen.

⚠ Retirez tous les matériaux d'emballage.

⚠ Rimuovere tutto il materiale di imballaggio.

22

2-

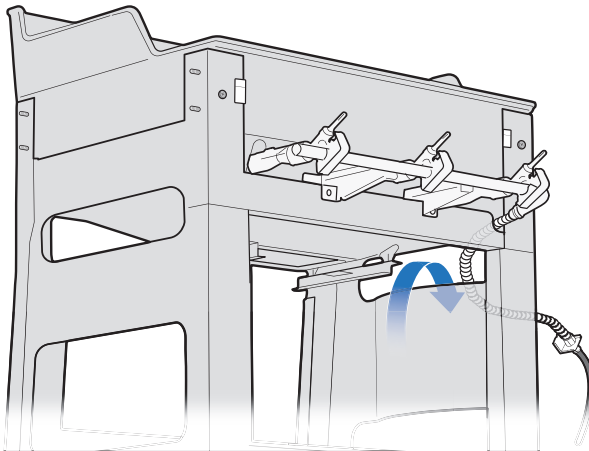
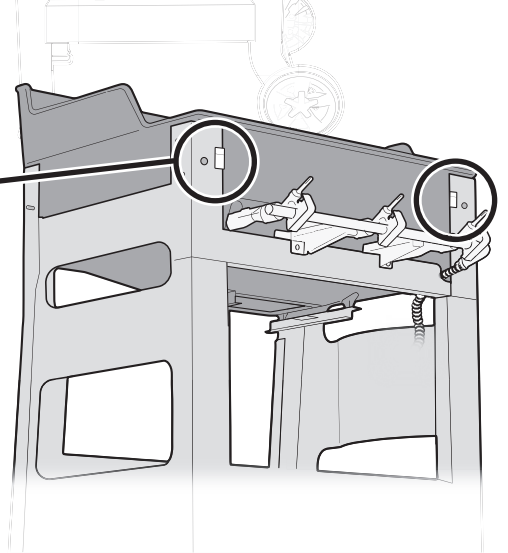
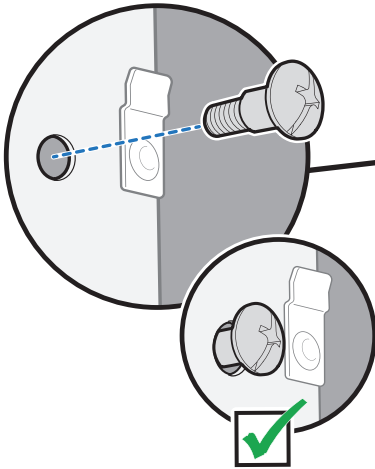
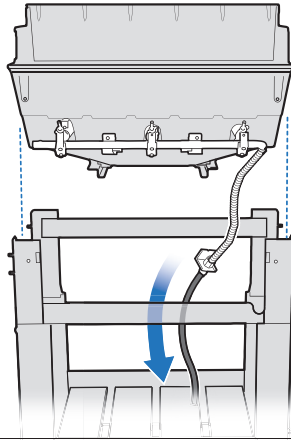
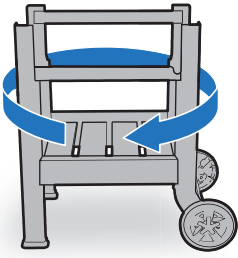

23

1- 

1- 

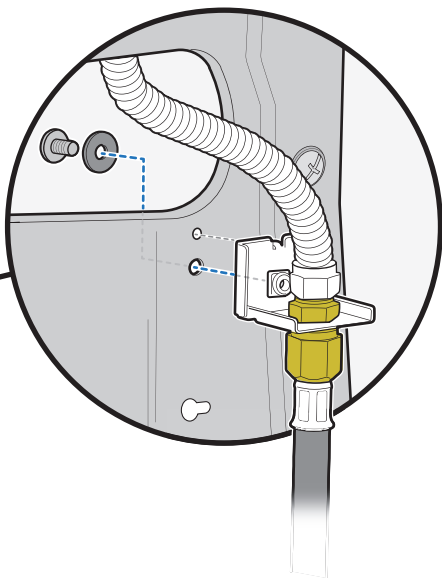
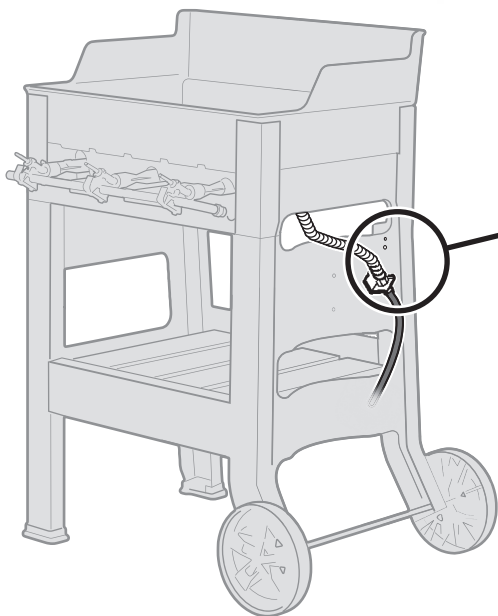

24

2- 

2- 

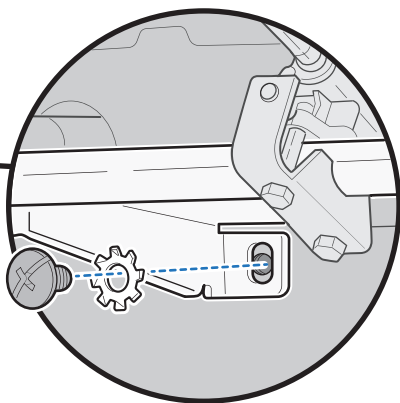
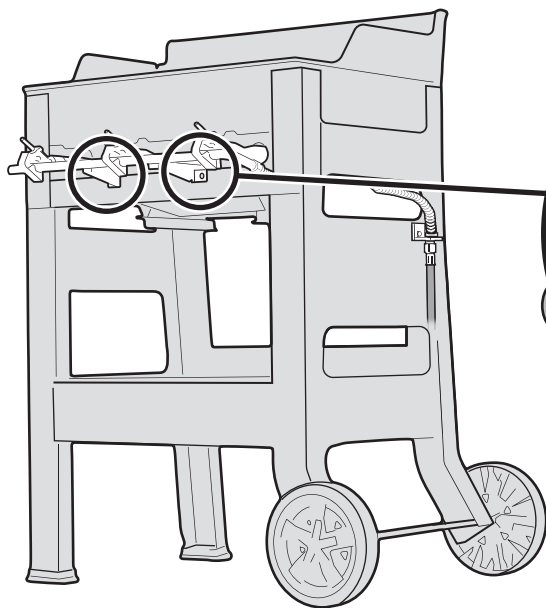

25

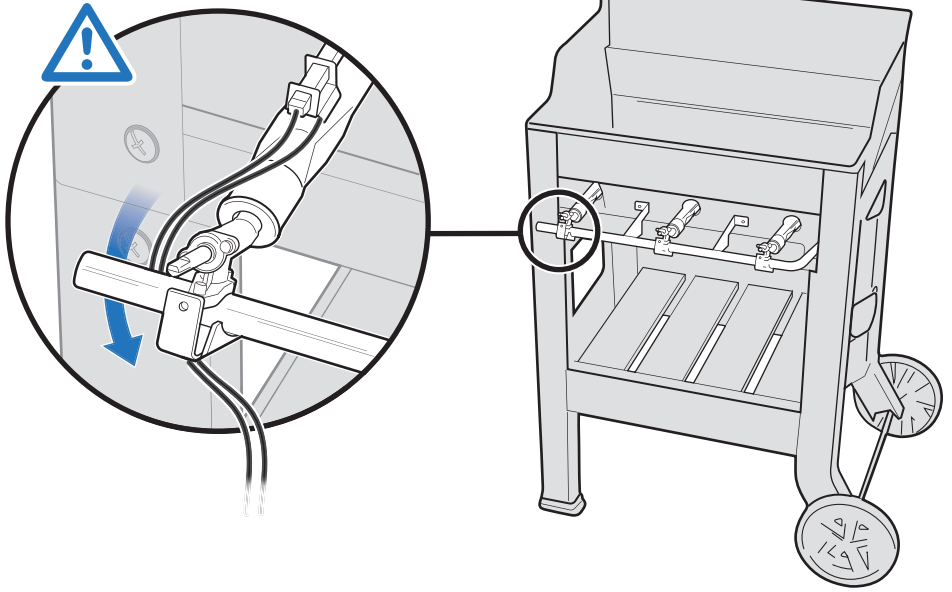

26

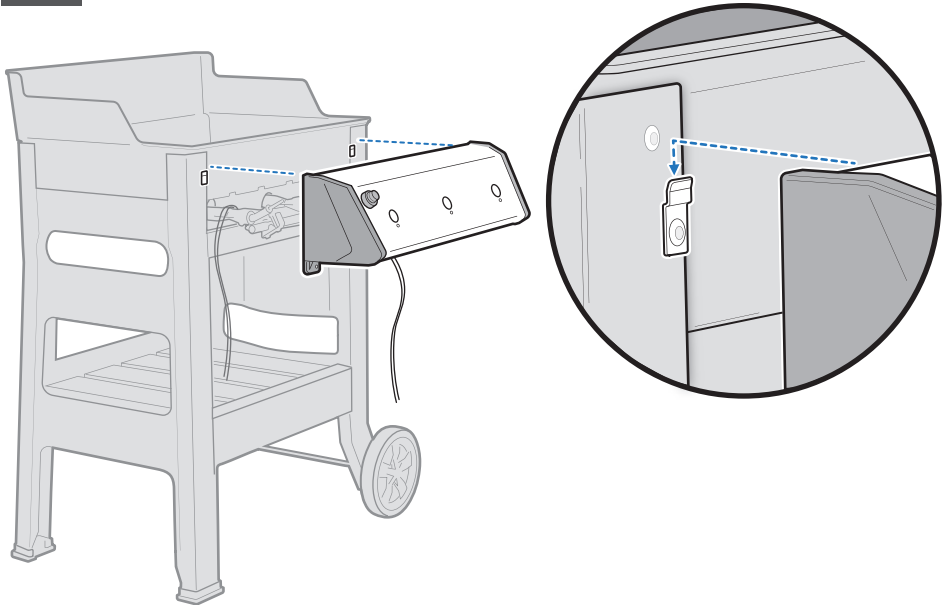

27

210

2-



2-



310

2-

3-

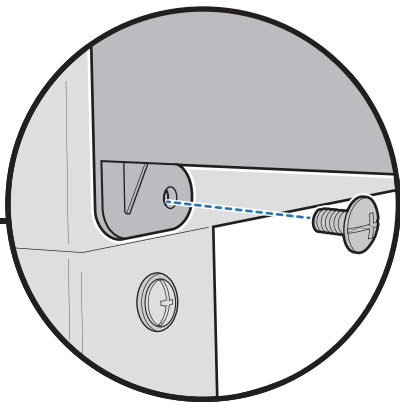
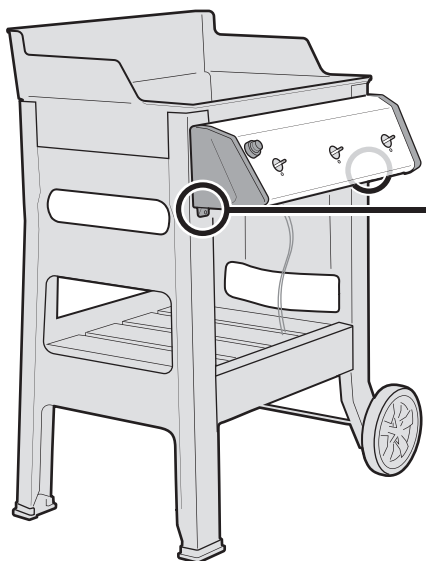
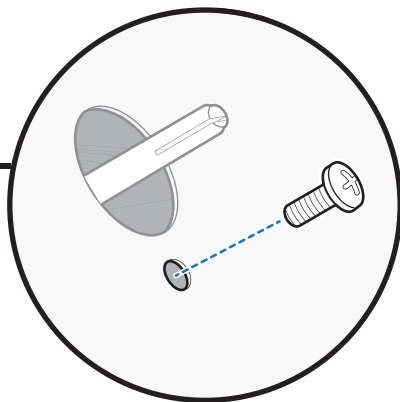
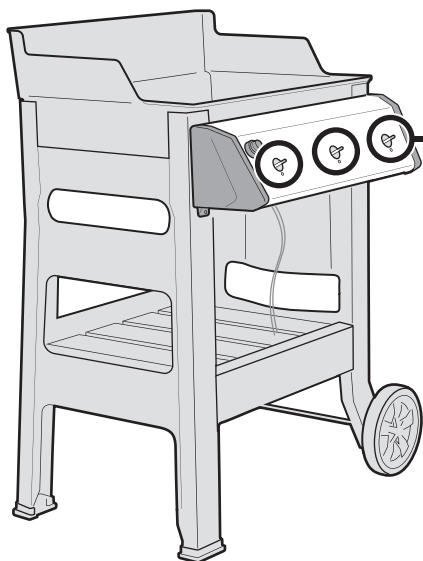

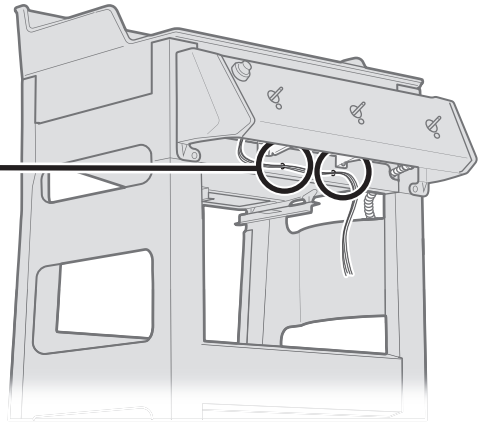
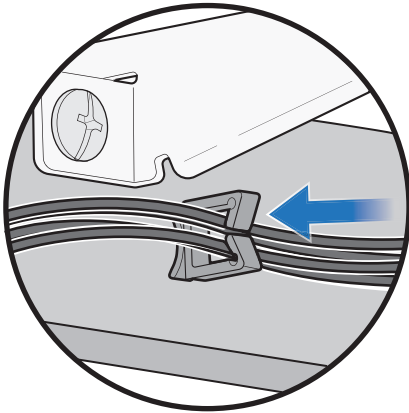
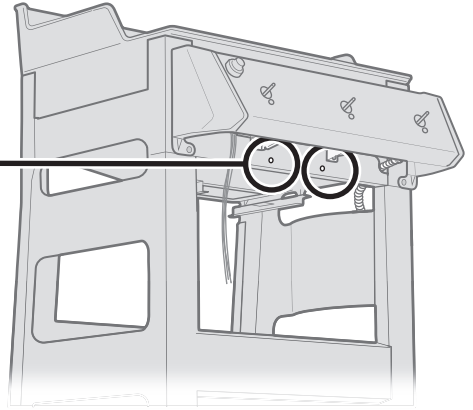
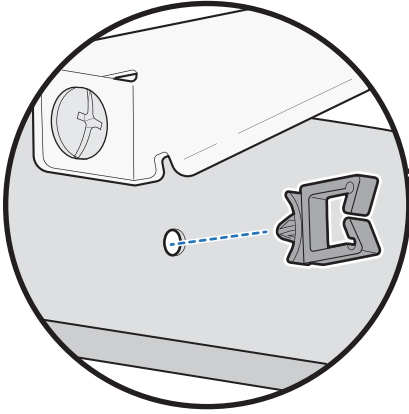

29



⚠ De bedrading moet **OM** de stalen gasleiding **HEEN** en **ACHER** de stalen gasleiding worden geleid.

⚠ Kabel müssen **UM** die Stahlgasleitung **HERUM** und **DAHINTER** verlegt werden.

⚠ Les câbles doivent **CONTOURNER** et passer **DERRIÈRE** la conduite de gaz en acier.

⚠ I cavi devono essere instradati **INTORNO** e **DIETRO** le linee del gas in acciaio.

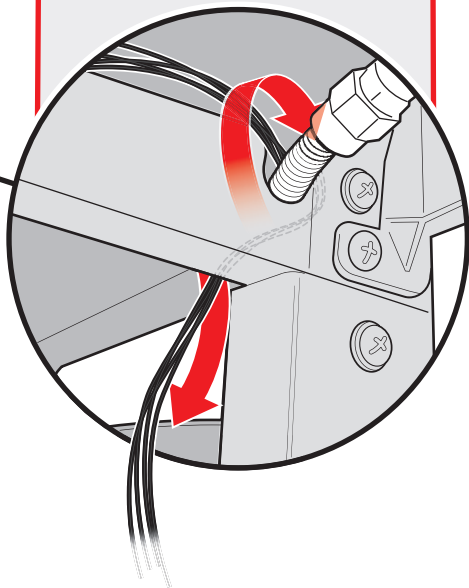
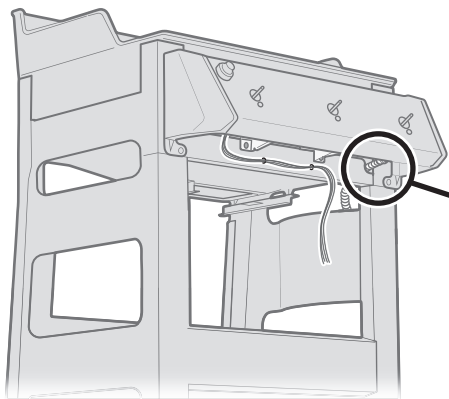

30

2-

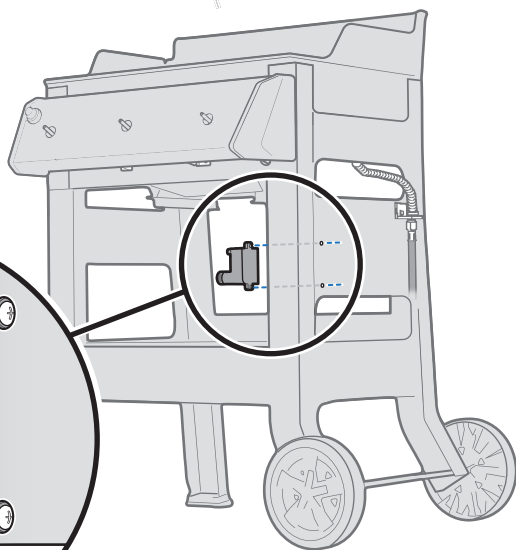
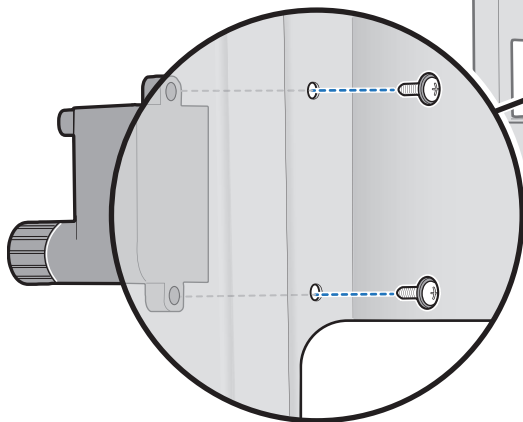

31

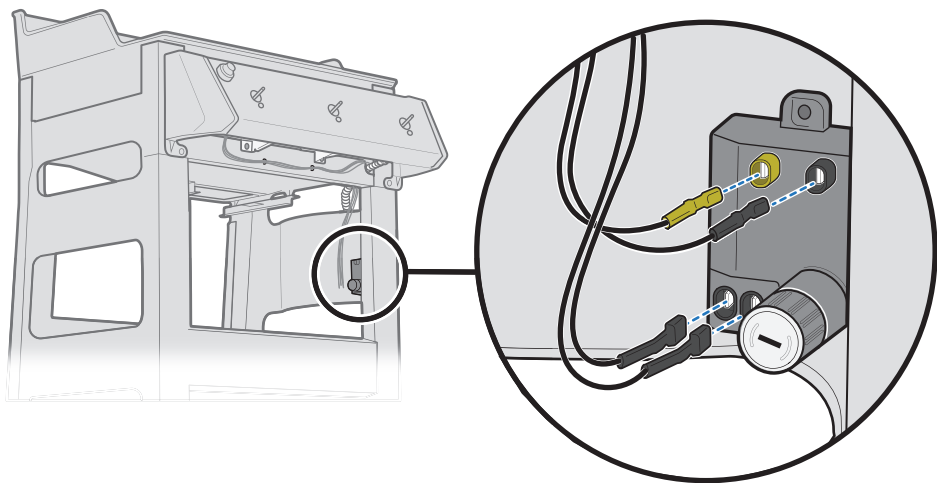

32

1-

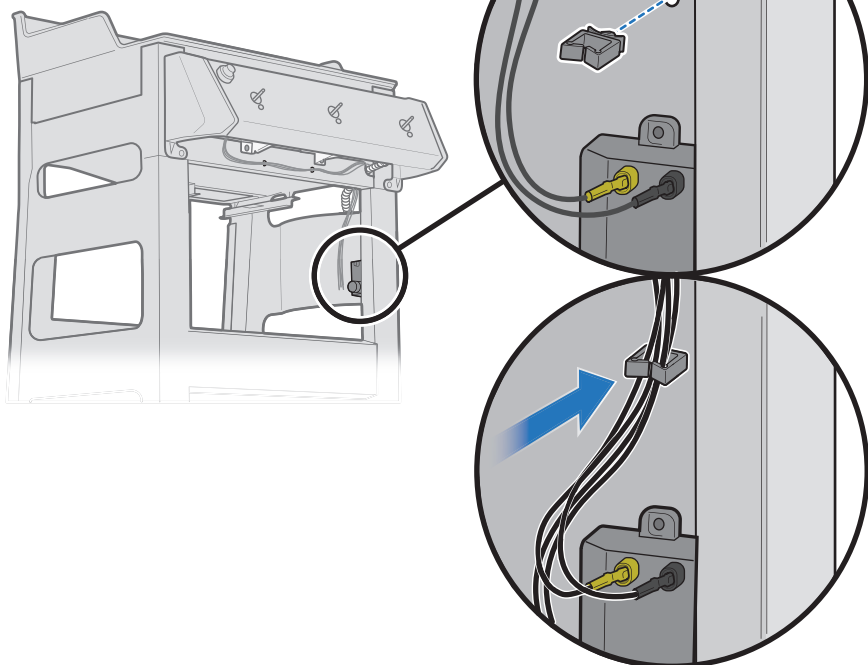

33

1-



D

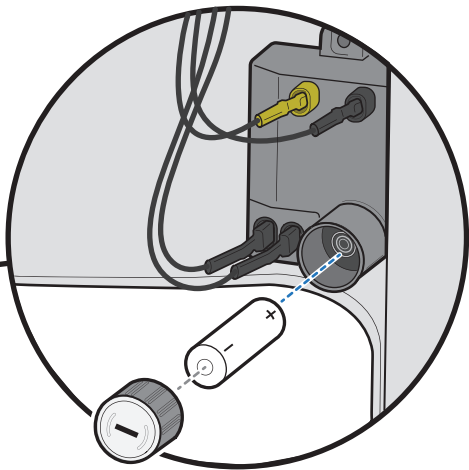
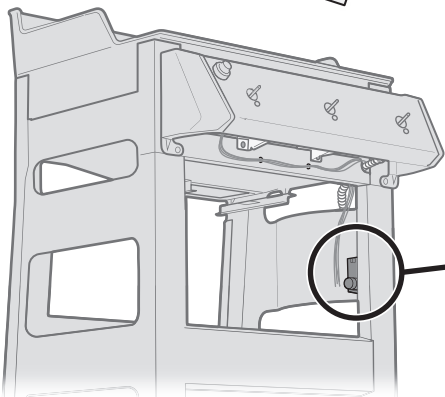

34

4-



2-



E

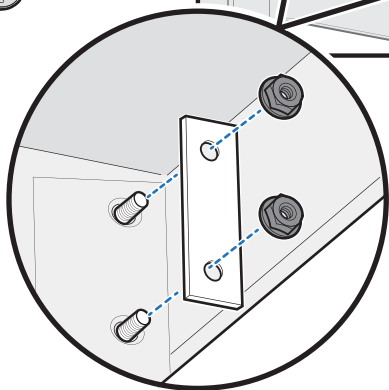
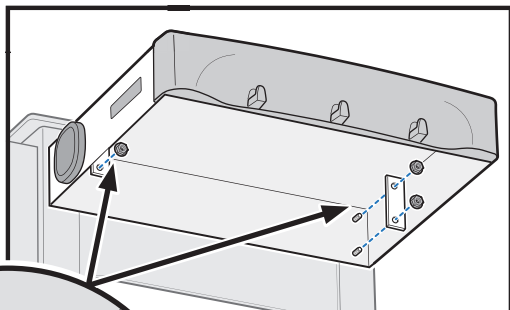
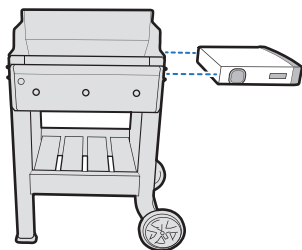

35

1-

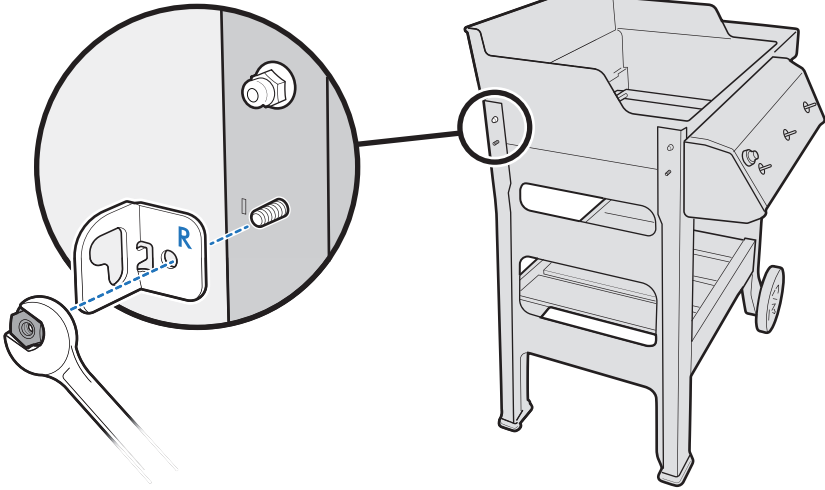

1-

**36**

1-



1-

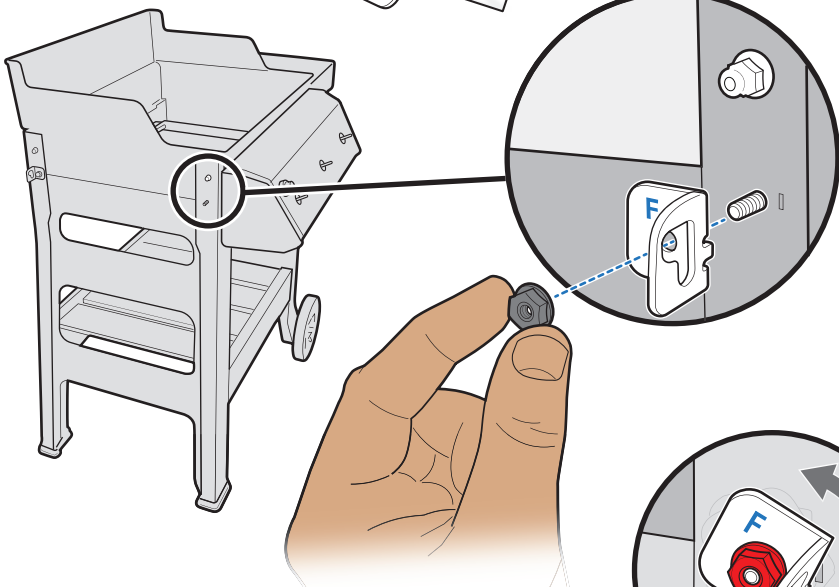

⚠ Draai de moer NIET volledig vast.

⚠ Mutter NICHT vollständig festziehen.

⚠ NE serrez PAS entièrement l'écrou.

⚠ NON serrare completamente il dado.

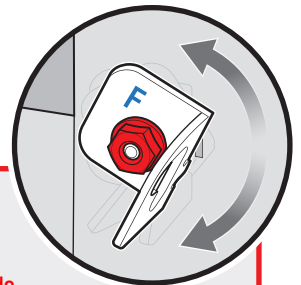

37

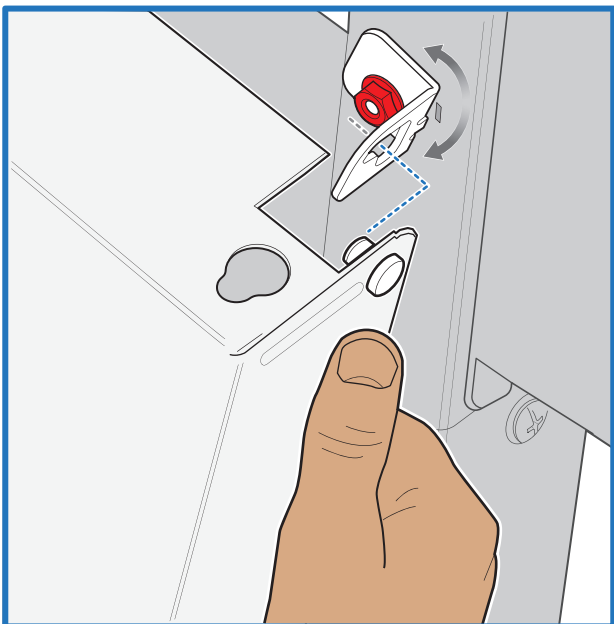
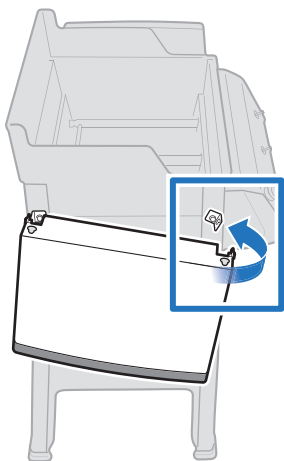
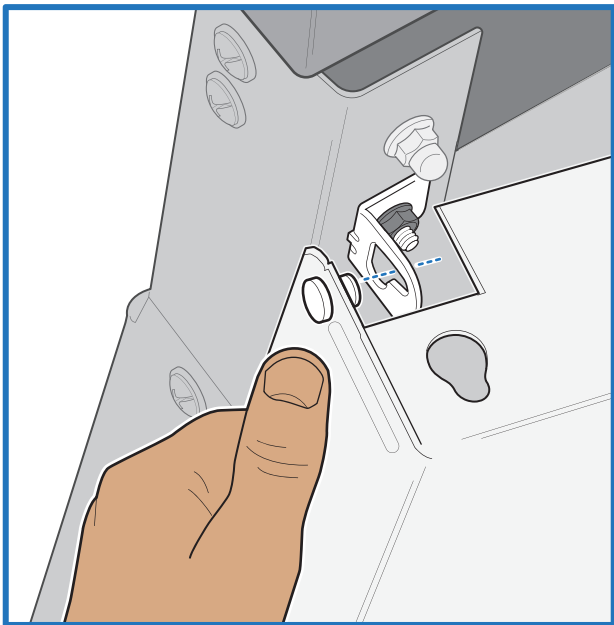
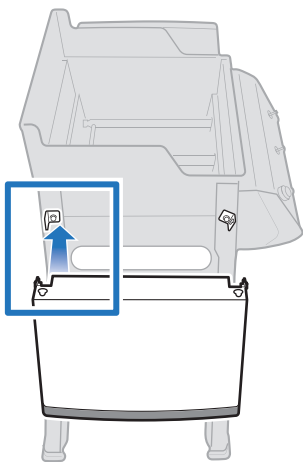



- ⚠ Klap het werkblad **VOORZICHTIG** omhoog en draai vervolgens de moer volledig vast.
- ⚠ Seitentisch **VORSICHTIG** anheben und dann Mutter vollständig festziehen.
- ⚠ Levez le plan de travail latéral **AVEC PRÉCAUTION** puis serrez complètement l'écrou.
- ⚠ Alzare **CON MOLTA ATTENZIONE** il ripiano laterale e quindi serrare completamente il dado.

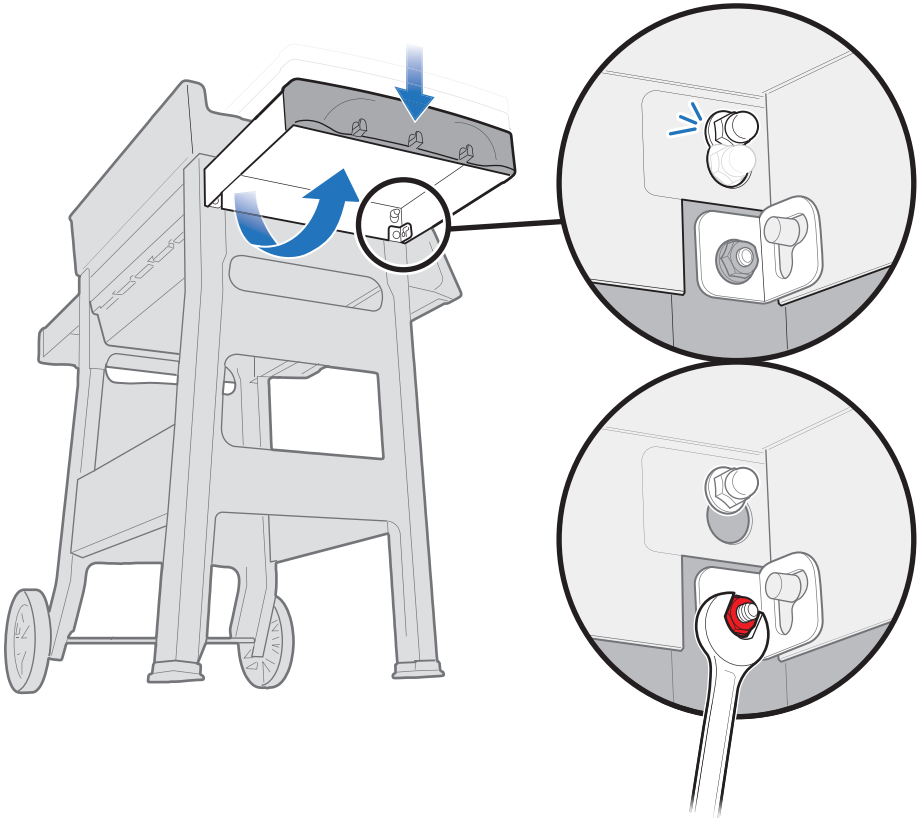

39

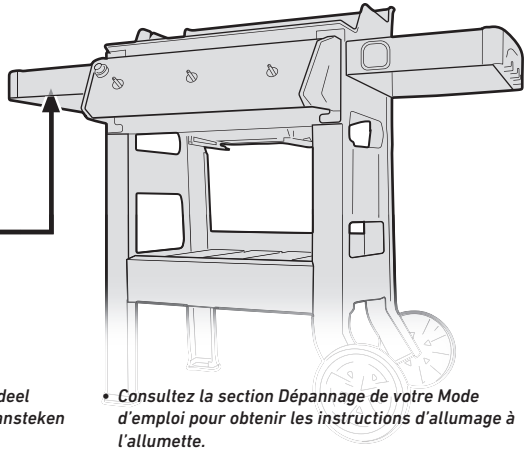
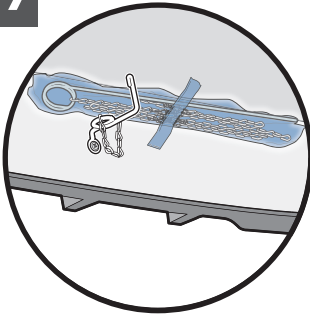

• Ga in de gebruikershandleiding naar het onderdeel Probleemoplossing voor instructies voor het aansteken met lucifers.

• Consultez la section Dépannage de votre Mode d'emploi pour obtenir les instructions d'allumage à l'allumette.

• Eine Anleitung zum manuellen Anzünden mit Streichhölzern findest du im Abschnitt „Fehlerbehebung“ in deinem Benutzerhandbuch.

• Per istruzioni sull'accensione con un fiammifero, fare riferimento alla sezione "Risoluzione dei problemi" nel Manuale utente.

40

4-  4- 

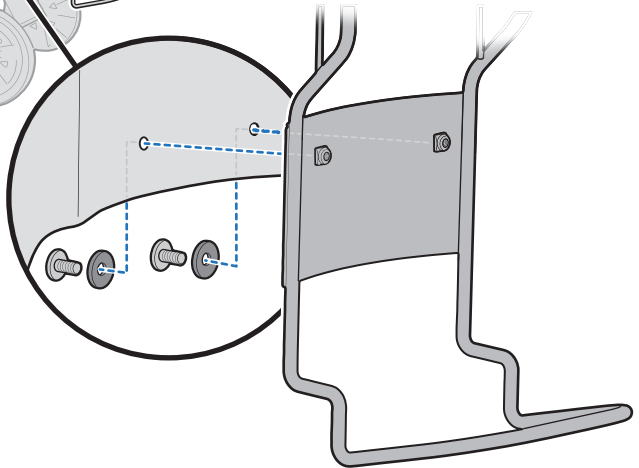
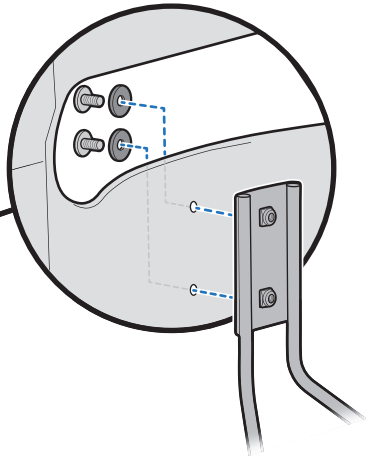
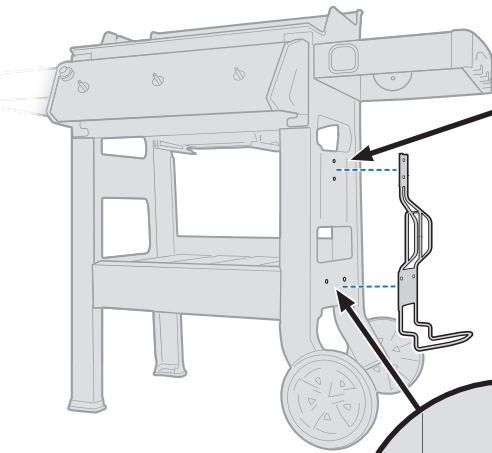

41

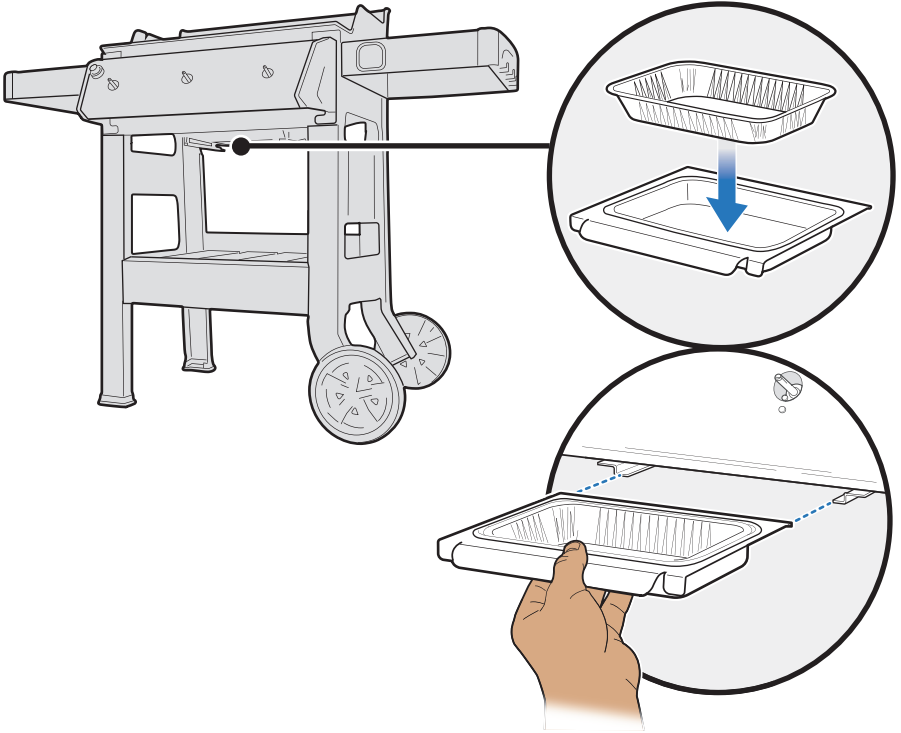

42

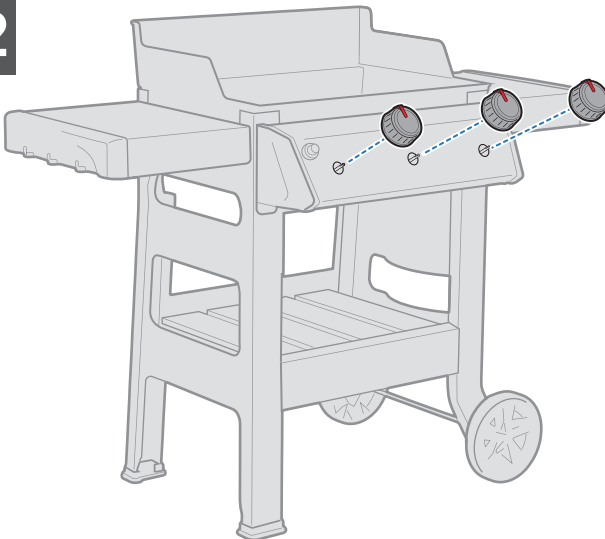

43

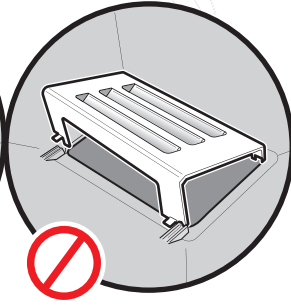
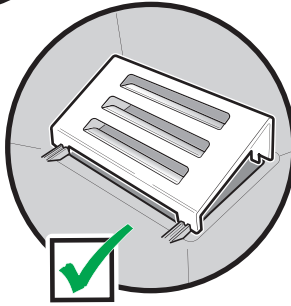
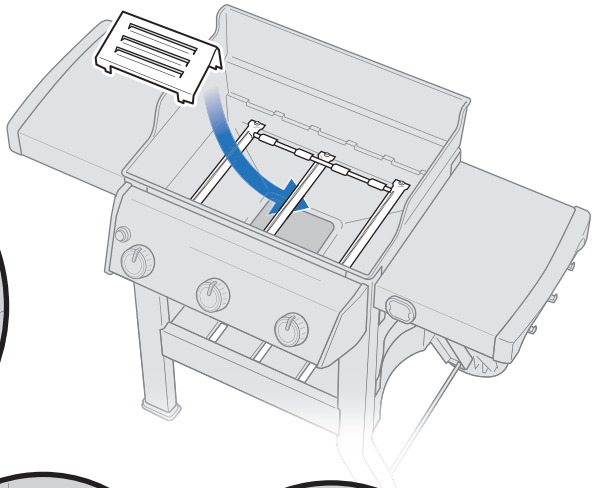
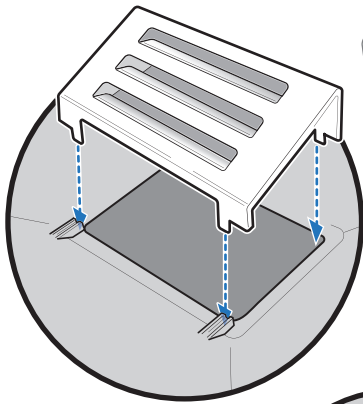

44

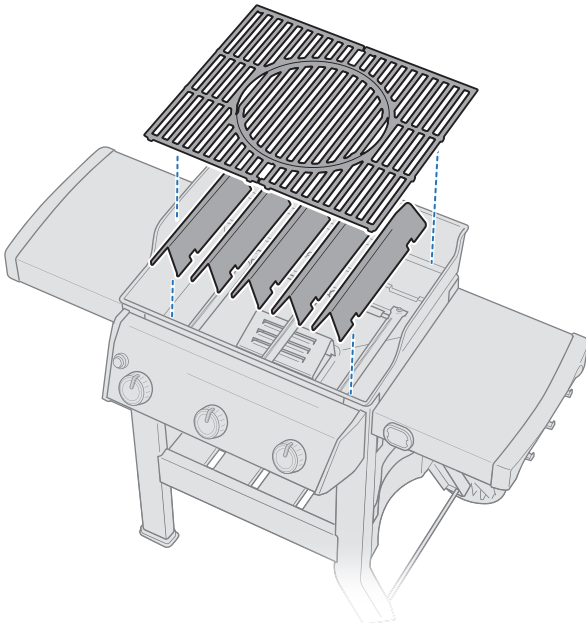

45

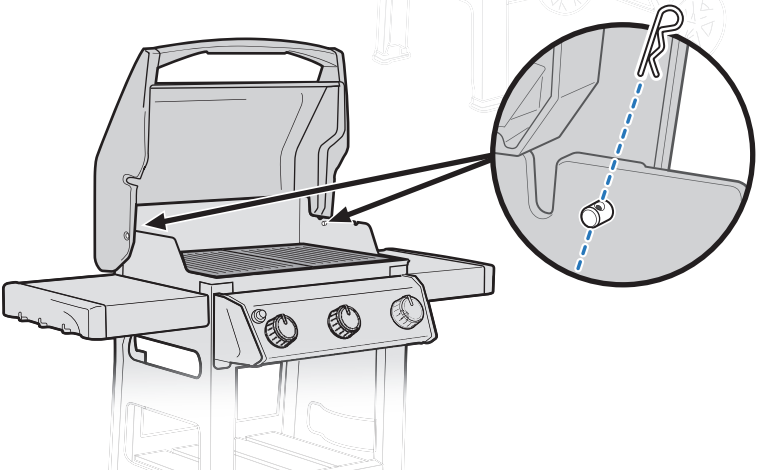
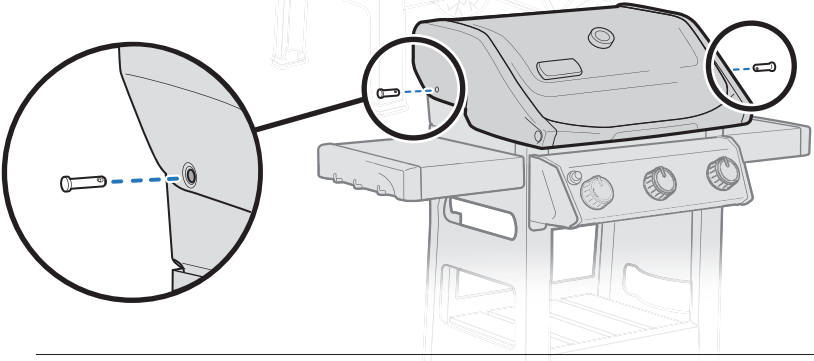
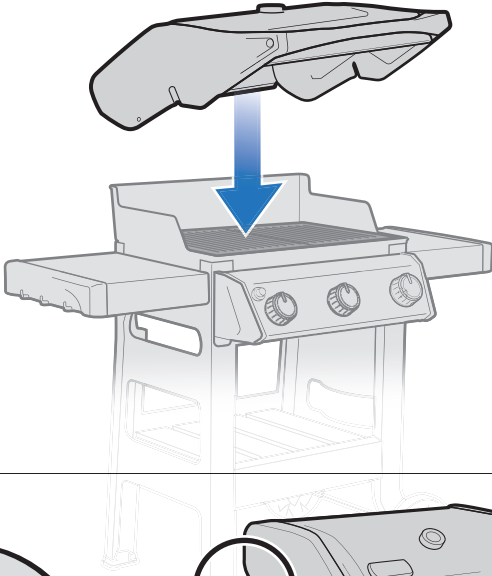

46

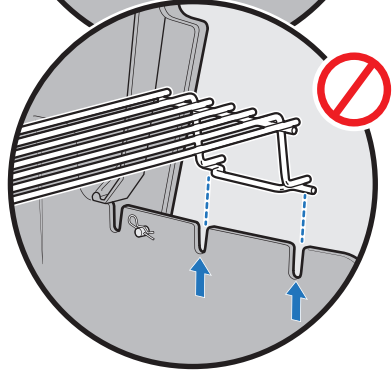
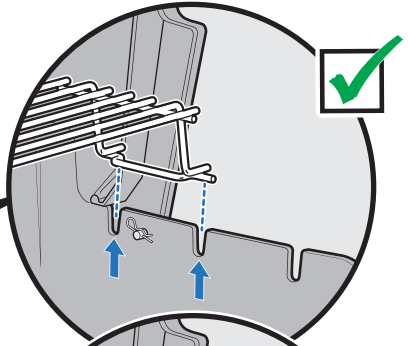
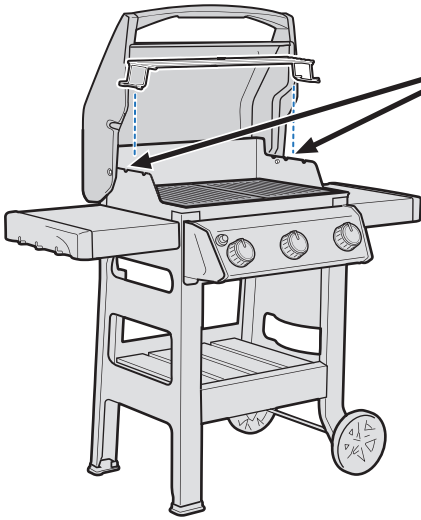
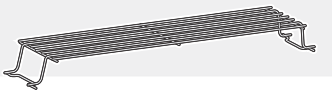

47

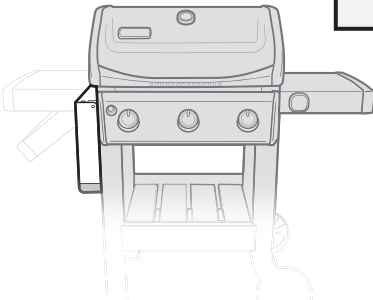
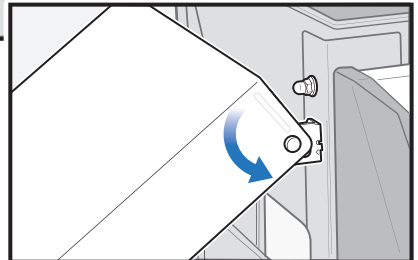
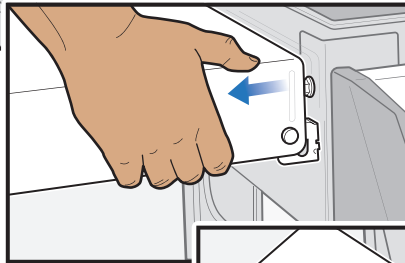
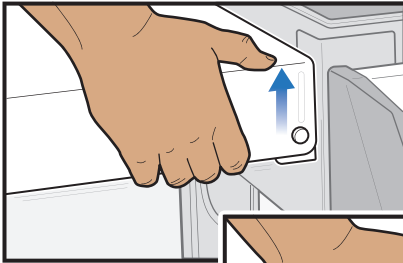

48

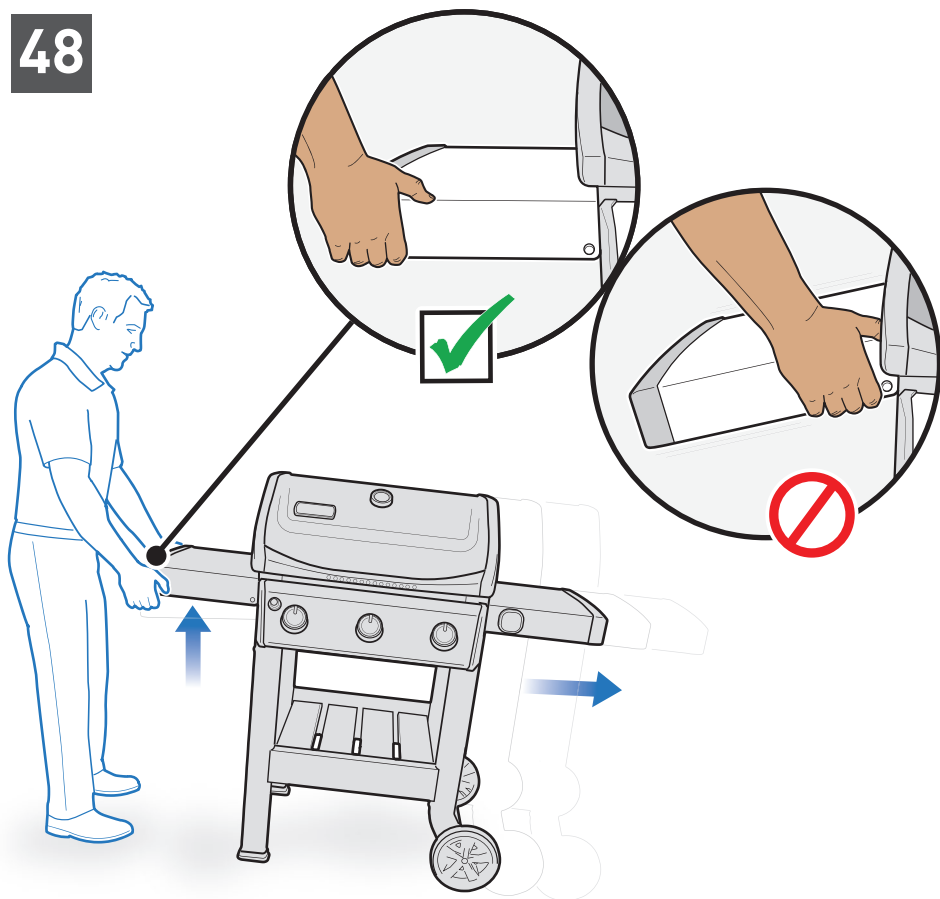

49

- Ga in de gebruikershandleiding naar het onderdeel Aan de slag voor meer informatie over gasaansluitingen en het controleren op lekken.
- Informationen zu den Gasanschlüssen und zur Leckageprüfung findest du im Abschnitt „Erste Schritte“ deines Benutzerhandbuchs.
- Consultez la section « Démarrage » de votre Mode d'emploi pour brancher l'alimentation en gaz et en vérifier l'étanchéité.
- Per l'allacciamento del gas e il controllo delle perdite, consultare la sezione "Operazioni preliminari" del manuale utente.

Registreeer Vandaag.
Registrieren Sie sich noch heute.
Enregistrez-le aujourd'hui.
Registrati oggi.

