

Test Report issued under the responsibility of:

**SGS Fimko Ltd.**

**TEST REPORT  
IEC 60335-2-80  
Safety of household and similar electrical appliances  
Part 2 : Particular requirements for fans**

**Report Number** ..... : GZES140901116201

**Date of issue** ..... : 2014-10-21

**Applicant's name** ..... : Techxin Electric Appliance Manufacture Co., Ltd.

**Address** ..... : 36 Haitanwei Zone, Zhoujun, Tangxia, Jiangmen, Guangdong, China

**Test specification:**

**Standard** ..... : IEC 60335-2-80:2002 (Second edition) + A1:2004 + A2:2008 in conj. With IEC 60335-1:2010 (Fifth Edition)

**Test procedure**..... : CB Scheme

**Non-standard test method**.....: N/A

**Test Report Form No.**..... : IEC60335\_2\_80E

**Test Report Form(s) Originator**.... : DEKRA Certification B.V.

**Master TRF** ..... : Dated 2012-09

**Copyright © 2012 Worldwide System for Conformity Testing and Certification of Electrotechnical Equipment and Components (IECEE), Geneva, Switzerland. All rights reserved.**

This publication may be reproduced in whole or in part for non-commercial purposes as long as the IECEE is acknowledged as copyright owner and source of the material. IECEE takes no responsibility for and will not assume liability for damages resulting from the reader's interpretation of the reproduced material due to its placement and context.

If this Test Report Form is used by non-IECEE members, the IECEE/IEC logo and the reference to the CB Scheme procedure shall be removed.

**This report is not valid as a CB Test Report unless signed by an approved CB Testing Laboratory and appended to a CB Test Certificate issued by an NCB in accordance with IECEE 02.**

**Test item description** ..... : Fan

**Trade Mark** ..... : **TECHXIN**

**Manufacturer** ..... : Same as applicant

**Model/Type reference**..... : TX-1208, TX-1208A, TX-1208B, TX-1608, TX-1608A, TX-1608B, TX-1608V, TX-1609, TX-1611, TX-1608BR, TX-1608VR, TX-1610R, TX-1611R, TX-1808A, TX-1811

**Ratings**..... : 220 V – 240 V; 50 Hz / 60 Hz; Class II; T  
TX-1208, TX-1208A, TX-1208B: 40W;  
TX-1608, TX-1608A, TX-1608B, TX-1608V, TX-1609, TX-1611, TX-1608BR, TX-1608VR, TX-1610R, TX-1611R: 45 W;  
TX-1808A, TX-1811: 60 W

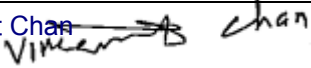
Testing procedure and testing location:		
<input checked="" type="checkbox"/>	<b>CB Testing Laboratory:</b>	SGS-CSTC Standards Technical Services Co., Ltd. - E&E Lab Guangzhou
Testing location/ address .....		198 Kezhu Road, Sciencetech Park, Guangzhou Economic & Technology Development District, Guangzhou, Guangdong, China 510663
<input checked="" type="checkbox"/>	<b>Associated Laboratory:</b>	SGS-CSTC Standards Technical Services Co., Ltd. - E&E Lab Shunde
Testing location/ address.....		1st Floor, Building 1 of European Industrial Park No. 1 Shunhenan Road Wusha Section, Daliang Town 528333 Shunde of Foshan Guangdong Province CHINA
	Tested by (name + signature):	Allen Zhang 
	Approved by (+ signature).....:	Vincent Chan 
<input type="checkbox"/>	<b>Testing procedure: TMP</b>	N/A
	Tested by (name + signature):	
	Approved by (+ signature).....:	
Testing location/ address.....		
<input type="checkbox"/>	<b>Testing procedure: WMT</b>	N/A
	Tested by (name + signature):	
	Witnessed by (+ signature):	
	Approved by (+ signature).....:	
Testing location/ address.....		
<input type="checkbox"/>	<b>Testing procedure: SMT</b>	N/A
	Tested by (name + signature):	
	Approved by (+ signature).....:	
	Supervised by (+ signature) .....	
Testing location/ address.....		
<input type="checkbox"/>	<b>Testing procedure: RMT</b>	N/A
	Tested by (name + signature):	
	Approved by (+ signature).....:	
	Supervised by (+ signature) .....	
Testing location/ address.....		

**List of Attachments:**

Attachment 1 includes IEC 60335-1: 2010/A1:2013.  
 Attachment 2 includes eu\_gd\_iec60335\_2\_80e.  
 Attachment 3 includes EN 60335-1 2012/A11:2014.  
 Attachment 4 includes photo documentation.  
 Attachment 5 includes circuit diagram.

**Summary of testing:**

**Tests performed (name of test and test clause):**

Tests according to the following standards were carried out:  
 IEC 60335-2-80: 2002 + A1: 2004 + A2: 2008  
 IEC 60335-1: 2010 + A1: 2013  
 EN 60335-2-80: 2003 + A1: 2004 + A2: 2009  
 EN 60335-1: 2012 + A11: 2014  
 EN 62233: 2008  
 After review, TX-1208A and TX-1808A were subjected to full tests.  
 TX-1610R with Synchronous motor WYJ50-8A1 was subjected to full tests and TX-1611R with synchronous motor TDY-50 was subjected to tests of clause 10, 11, 13, 19.7, 19.11.2, 23.3 and construction check.  
 The other models were subjected to construction check.  
 The submitted samples fulfil the requirements of above standards.

**Testing location:**

See page 2 of ACTL

**Summary of compliance with National Differences**

CENELEC common modifications and national differences for Germany were taken into account. Requirements in German legislation ProdSG and EK decisions for electrical equipment have been taken into account. Risk analysis and evaluation for PAH has been performed (ref. ZEK 01.4-08, EK1 374-08e Rev2).

**Copy of marking plate:**

The artwork below may be only a draft. The use of certification marks on a product must be authorized by the respective NCBs that own these marks.

**English**

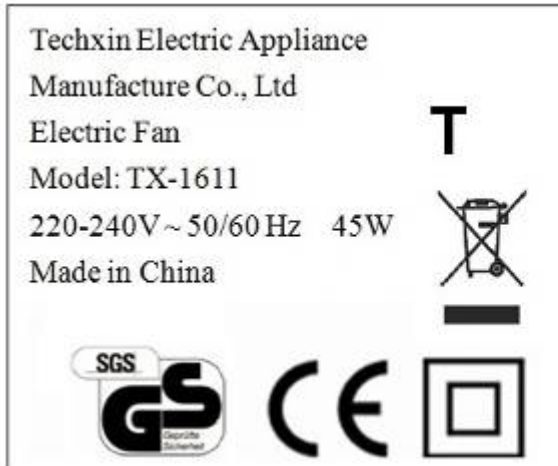

**German**



Remark: Other marking plates are same as above except model name and ratings.

<b>Test item particulars</b> .....	
Classification of installation and use.....	Portable appliance for household use
Supply Connection .....	Non-detachable cord fitted with a plug
<b>Possible test case verdicts:</b>	
- test case does not apply to the test object.....	N/A
- test object does meet the requirement.....	P (Pass)
- test object does not meet the requirement.....	F (Fail)
<b>Testing</b> .....	
Date of receipt of test item .....	2014-09-29
Date (s) of performance of tests .....	2014-09-30 to 2014-10-18
<b>General remarks:</b>	
<p><b>The test results presented in this report relate only to the object tested.</b>  <b>This report shall not be reproduced, except in full, without the written approval of the Issuing testing laboratory.</b>  <b>"(see Enclosure #)" refers to additional information appended to the report.</b>  <b>"(see appended table)" refers to a table appended to the report.</b></p> <p><b>Throughout this report a <input checked="" type="checkbox"/> comma / <input type="checkbox"/> point is used as the decimal separator.</b></p> <p>This document is issued by the Company subject to its General Conditions of Service, available on request or accessible at <a href="http://www.sgs.com/en/Terms-and-Conditions.aspx">http://www.sgs.com/en/Terms-and-Conditions.aspx</a> and, for electronic format documents, subject to Terms and Conditions for Electronic Documents at <a href="http://www.sgs.com/en/Terms-and-Conditions/Terms-e-Document.aspx">http://www.sgs.com/en/Terms-and-Conditions/Terms-e-Document.aspx</a>. Attention is drawn to the limitation of liability, indemnification and jurisdiction issues defined therein. Any holder of this document is advised that information contained hereon reflects the Company's findings at the time of its intervention only and within the limits of Client's instructions, if any. The Company's sole responsibility is to its Client and this document does not exonerate parties to a transaction from exercising all their rights and obligations under the transaction documents. This document cannot be reproduced except in full, without prior written approval of the Company. Any unauthorized alteration, forgery or falsification of the content or appearance of this document is unlawful and offenders may be prosecuted to the fullest extent of the law.</p> <p>Unless otherwise stated the results shown in this test report refer only to the sample(s) tested and such sample(s) are retained for 12 months only.</p>	
<b>Manufacturer's Declaration per sub-clause 6.2.5 of IEC60335-1:</b>	
<p><b>The application for obtaining a CB Test Certificate includes more than one factory location and a declaration from the Manufacturer stating that the sample(s) submitted for evaluation is (are) representative of the products from each factory has been provided</b> .....</p>	<p><input type="checkbox"/> Yes  <input checked="" type="checkbox"/> Not applicable</p>
<b>When differences exist; they shall be identified in the General product information section.</b>	
<b>Name and address of factory (ies)</b> .....	Same as applicant

**General product information:**

Fan for household and indoor use only.

The power cords H03VVH2-F are applicable for models which do not exceed 3kg after installing with alternative fan guard or pedestal. Details see attachment 4 photo documentation.

For detail information about the difference of all models, please see below table and attachment 4 photo documentation. For relevant tests, see “summary of testing”.

Model number	Mechanical type	Incorporated with timer	Electronic type	Incorporated with synchronous motor	Pedestal	Rating power input	Motor
TX-1608A	Yes	Yes	--	--	“+” shape	45 W	M-1608
TX-1608B	Yes	--	--	--	“+” shape	45 W	M-1608
TX-1608BR	--	--	Yes	--	“+” shape	45 W	M-1608
TX-1610R	--	--	Yes	Yes	Round	45 W	M-1608
TX-1611R	--	--	Yes	Yes	Round	45 W	M-1608
TX-1608	Yes	--	--	--	“+” shape	45 W	M-1608
TX-1808A	Yes	Yes	--	--	Round	60 W	M-1808
TX-1811	Yes	Yes	--	--	Round	60 W	M-1808
TX-1208	Yes	--	--	--	“+” shape	40 W	M-1208
TX-1208A	Yes	Yes	--	--	“+” shape	40 W	M-1208
TX-1208B	Yes	--	--	--	“+” shape	40 W	M-1208
TX-1608V	Yes	--	--	--	“+” shape or Round	45 W	M-1608
TX-1609	Yes	--	--	--	“+” shape or Round	45 W	M-1608
TX-1611	Yes	Yes	--	--	“+” shape or Round	45 W	M-1608
TX-1608VR	--	--	Yes	--	“+” shape or Round	45 W	M-1608

IEC 60335-2-80			
Clause	Requirement - Test	Result - Remark	Verdict
5	GENERAL CONDITIONS FOR THE TESTS		--
	Tests performed according to clause 5, e.g. nature of supply, sequence of testing, etc.		P
5.7	Fans to be used in tropical climates, the tests of clause 10,11 and 13 are carried out at 40 °C +/- 2 °C (IEC 60335-2-80)		P
	Fans marked with ambient operating temperature, the tests of clause 10, 11 and 13 are carried out at marked value +/- 2 °C (IEC 60335-2-80/A1)		N/A
6	CLASSIFICATION		--
6.1	Protection against electric shock: Class 0, 0I, I, II, III .....	Class II	P
6.2	Protection against harmful ingress of water	IPX0	N/A
	At least IPX2 for Duct fans (IEC 60335-2-8)		N/A
6.101	Classification to climatic conditions : temperature climates, tropical climates (IEC 60335-2-8)	Tropical climates	P
7	MARKING AND INSTRUCTIONS		--
7.1	Rated voltage or voltage range (V) .....	220 V – 240 V	P
	Symbol for nature of supply, or .....	~	P
	Rated frequency (Hz) .....	50 Hz / 60 Hz	P
	Rated power input (W), or .....	See page 1	P
	Rated current (A) .....		N/A
	Manufacturer's or responsible vendor's name, trademark or identification mark.....	<b>TECHXIN</b>	P
	Model or type reference .....	See page 1	P
	Symbol IEC 60417-5172, for class II appliances		P
	IP number, other than IPX0.....		N/A
	Symbol IEC 60417-5180, for class III appliances, unless		N/A
	the appliance is operated by batteries only		N/A
	Symbol IEC 60417-5036, for the enclosure of electrically-operated water valves in external hose-sets for connection of an appliance to the water mains, if the working voltage exceeds extra-low voltage		N/A

IEC 60335-2-80			
Clause	Requirement - Test	Result - Remark	Verdict
	For tropical climates marked with letter T (IEC 60335-2-80)		P
	Fans intended for operation in location where the local temperature exceeds 40 °C shall be marked with the ambient operating temperature. (IEC 60335-2-80/A1)		N/A
7.2	Warning for stationary appliances for multiple supply		N/A
	Warning placed in vicinity of terminal cover		N/A
7.3	Range of rated values marked with the lower and upper limits separated by a hyphen		P
	Different rated values marked with the values separated by an oblique stroke		N/A
7.4	Appliances adjustable for different rated voltages, the voltage setting is clearly discernible		N/A
	Requirement met if frequent changes are not required and the rated voltage to which the appliance is to be adjusted is determined from a wiring diagram		N/A
7.5	Appliances with more than one rated voltage or one or more rated voltage ranges		P
	marked with rated input or rated current for each rated voltage or range, unless		N/A
	the power input is related to the arithmetic mean value of the rated voltage range		P
	Relation between marking for upper and lower limits of rated power input or rated current and voltage is clear		N/A
7.6	Correct symbols used		P
	Symbol for nature of supply placed next to rated voltage		P
	Symbol for class II appliances placed unlikely to be confused with other marking		P
	Units of physical quantities and their symbols according to international standardized system		P
7.7	Connection diagram fixed to appliances to be connected to more than two supply conductors and appliances for multiple supply, unless		N/A
	correct mode of connection is obvious		N/A
7.8	Except for type Z attachment, terminals for connection to the supply mains indicated as follows:		--



IEC 60335-2-80			
Clause	Requirement - Test	Result - Remark	Verdict
	- marking of terminals exclusively for the neutral conductor (letter N)		N/A
	- marking of protective earthing terminals (symbol IEC 60417-5019)		N/A
	- marking not placed on removable parts		N/A
7.9	Marking or placing of switches which may cause a hazard		P
7.10	Indications of switches on stationary appliances and controls on all appliances by use of figures, letters or other visual means .....	By use of figures and letters	P
	This applies also to switches which are part of a control		P
	If figures are used, the off position indicated by the figure 0		P
	The figure 0 indicates only OFF position, unless no confusion with the OFF position		P
7.11	Indication for direction of adjustment of controls		P
7.12	Instructions for safe use provided		P
	Details concerning precautions during user maintenance		P
	The instructions state that:		--
	- the appliance is not to be used by persons (including children) with reduced physical, sensory or mental capabilities, or lack of experience and knowledge, unless they have been given supervision or instruction		P
	- children being supervised not to play with the appliance		P
	For a part of class III construction supplied from a detachable power supply unit, the instructions state that the appliance is only to be used with the unit provided		N/A
	Instructions for class III appliances state that it must only be supplied at SELV, unless		N/A
	it is a battery-operated appliance, the battery being charged outside the appliance		N/A
	For the guards have to be removed purpose for cleaning should: (IEC 60335-2-80/A1)		--
	Ensure that the fan is switched off from the supply mains before removing the guard.		P
7.12.1	Sufficient details for installation supplied		P

IEC 60335-2-80			
Clause	Requirement - Test	Result - Remark	Verdict
	For an appliance intended to be permanently connected to the water mains and not connected by a hose-set, this is stated		N/A
	The installation instructions include the substance of the following: (IEC 60335-2-80)		--
	- the model or type reference of a luminaire		N/A
	- mounting location for partition fans		N/A
	- The installation height for fans intended to be mounted at high level		N/A
	- that precautions for duct and partition fans.		N/A
7.12.2	Stationary appliances not fitted with means for disconnection from the supply mains having a contact separation in all poles that provide full disconnection under overvoltage category III, the instructions state that means for disconnection must be incorporated in the fixed wiring in accordance with the wiring rules	Portable appliance	N/A
7.12.3	Insulation of the fixed wiring in contact with parts exceeding 50 K during clause 11; instructions state that the fixed wiring must be protected		N/A
7.12.4	Instructions for built-in appliances:		--
	- dimensions of space		N/A
	- dimensions and position of supporting and fixing		N/A
	- minimum distances between parts and surrounding structure		N/A
	- minimum dimensions of ventilating openings and arrangement		N/A
	- connection to supply mains and interconnection of separate components		N/A
	- allow disconnection of the appliance after installation, by accessible plug or a switch in the fixed wiring, unless		N/A
	a switch complying with 24.3		N/A
7.12.5	Replacement cord instructions, type X attachment with a specially prepared cord		N/A
	Replacement cord instructions, type Y attachment		P
	Replacement cord instructions, type Z attachment		N/A
7.12.6	Caution in the instructions for appliances incorporating a non-self-resetting thermal cut-out that is reset by disconnection of the supply mains, if this cut-out is required to comply with the standard		N/A

IEC 60335-2-80			
Clause	Requirement - Test	Result - Remark	Verdict
7.12.7	Instructions for fixed appliances stating how the appliance is to be fixed		N/A
7.12.8	Instructions for appliances connected to the water mains:		--
	- max. inlet water pressure (Pa).....:		N/A
	- min. inlet water pressure, if necessary (Pa).....:		N/A
	Instructions concerning new and old hose-sets for appliances connected to the water mains by detachable hose-sets		N/A
7.13	Instructions and other texts in an official language	English and German	P
7.14	Marking clearly legible and durable, rubbing test as specified		P
7.15	Markings on a main part		P
	Marking clearly discernible from the outside, if necessary after removal of a cover		P
	For portable appliances, cover can be removed or opened without a tool		N/A
	For stationary appliances, name, trademark or identification mark and model or type reference visible after installation		N/A
	For fixed appliances, name, trademark or identification mark and model or type reference visible after installation according to the instructions		N/A
	Indications for switches and controls placed on or near the components. Marking not on parts which can be positioned or repositioned in such a way that the marking is misleading		P
7.16	Marking of a possible replaceable thermal link or fuse link clearly visible with regard to replacing the link		N/A
8	PROTECTION AGAINST ACCESS TO LIVE PARTS		--
8.1	Adequate protection against accidental contact with live parts		P
8.1.1	Requirement applies for all positions, detachable parts removed		P
	Lamps behind a detachable cover not removed, if conditions met		N/A
	Insertion or removal of lamps, protection against contact with live parts of the lamp cap		N/A
	Use of test probe B of IEC 61032, with a force not exceeding 1 N: no contact with live parts		P

IEC 60335-2-80			
Clause	Requirement - Test	Result - Remark	Verdict
	Lamps are not removed. However, during insertion or removal of lamps, no contact with live parts of the lamp cap. (IEC 60335-2-80)		N/A
8.1.2	Use of test probe 13 of IEC 61032, with a force not exceeding 1 N, through openings in class 0 appliances and class II appliances/constructions: no contact with live parts		P
	Test probe 13 also applied through openings in earthed metal enclosures having a non-conductive coating: no contact with live parts		N/A
8.1.3	For appliances other than class II, use of test probe 41 of IEC 61032, with a force not exceeding 1 N: no contact with live parts of visible glowing heating elements		N/A
8.1.4	Accessible part not considered live if:		--
	- safety extra-low a.c. voltage: peak value not exceeding 42.4 V		N/A
	- safety extra-low d.c. voltage: not exceeding 42.4 V		N/A
	- or separated from live parts by protective impedance		N/A
	If protective impedance: d.c. current not exceeding 2 mA, and		N/A
	a.c. peak value not exceeding 0.7 mA		N/A
	- for peak values over 42.4 V up to and including 450 V, capacitance not exceeding 0,1 μF		N/A
	- for peak values over 450 V up to and including 15 kV, discharge not exceeding 45 μC		N/A
	- for peak values over 15kV, the energy in the discharge not exceeding 350 mJ		N/A
8.1.5	Live parts protected at least by basic insulation before installation or assembly:		--
	- built-in appliances		N/A
	- fixed appliances		N/A
	- appliances delivered in separate units		N/A
8.2	Class II appliances and constructions constructed so that there is adequate protection against accidental contact with basic insulation and metal parts separated from live parts by basic insulation only		P
	Only possible to touch parts separated from live parts by double or reinforced insulation		P

IEC 60335-2-80			
Clause	Requirement - Test	Result - Remark	Verdict
8.2	Remove the detachable parts for user maintenance purpose, the basic insulation of internal wiring may be touched provide the equivalent insulating of cords complying with IEC 60227 or IEC 60245. (IEC 60335-2-80/A1)		N/A
9	STARTING OF MOTOR-OPERATED APPLIANCES		--
	Requirements and tests are specified in part 2 when necessary		N/A
10	POWER INPUT AND CURRENT		--
10.1	Power input at normal operating temperature, rated voltage and normal operation not deviating from rated power input by more than shown in table 1 .:	(see appended table)	P
	Test carried out at upper and lower limits of the ranges for appliances with one or more rated voltage ranges, unless		N/A
	the rated power input is related to the arithmetic mean value		P
	Appliances are tested with shutters or similar devices in the open position.(IEC 60335-2-80)		N/A
10.2	Current at normal operating temperature, rated voltage and normal operation not deviating from rated current by more than shown in table 2.....:		N/A
	Test carried out at upper and lower limits of the ranges for appliances with one or more rated voltage ranges, unless		N/A
	the rated current is related to the arithmetic mean value of the range		N/A
	Appliances are tested with shutters or similar devices in the open position. (IEC 60335-2-80)		N/A
11	HEATING		--
11.1	No excessive temperatures in normal use		P
11.2	The appliance is held, placed or fixed in position as described .....	Placed on floor	P
11.3	Temperature rises, other than of windings, determined by thermocouples		P
	Temperature rises of windings determined by resistance method, unless		P
	the windings are non-uniform or it is difficult to make the necessary connections		N/A
11.4	Heating appliances operated under normal operation at 1.15 times rated power input (W) .....		N/A

IEC 60335-2-80			
Clause	Requirement - Test	Result - Remark	Verdict
11.5	Motor-operated appliances operated under normal operation at most unfavourable voltage between 0.94 and 1.06 times rated voltage (V) .....	254,4 V	P
11.6	Combined appliances operated under normal operation at most unfavourable voltage between 0.94 and 1.06 times rated voltage (V) .....		N/A
11.7	Appliances are operated until steady conditions are established. (IEC 60335-2-80)		P
11.8	Temperature rises monitored continuously and not exceeding the values in table 3 .....	(see appended table)	P
	If the temperature rise of a motor winding exceeds the value of table 3, or		N/A
	if there is doubt with regard to classification of insulation,		N/A
	tests of Annex C are carried out		N/A
	Sealing compound does not flow out		P
	Protective devices do not operate, except		P
	components in protective electronic circuits tested for the number of cycles specified in 24.1.4		N/A
	The temperature rise limits for appliances for tropical climates are reduced by 15 K. (IEC 60335-2-80)		P
	The temperature rise limits for fans marked with an ambient operating temperature are reduced by the difference between the marked value and 25 °C. (IEC 60335-2-80/A1)		N/A
13	LEAKAGE CURRENT AND ELECTRIC STRENGTH AT OPERATING TEMPERATURE		--
13.1	Leakage current not excessive and electric strength adequate		P
	Heating appliances operated at 1.15 times the rated power input (W) .....		N/A
	Motor-operated appliances and combined appliances supplied at 1.06 times the rated voltage (V) .....	254,4 V	P
	Protective impedance and radio interference filters disconnected before carrying out the tests		N/A
13.2	For class 0, class II and class III appliances, leakage current measured by means of the circuit described in figure 4 of IEC 60990	Class II	P
	For other appliances, a low impedance ammeter may be used		N/A

IEC 60335-2-80			
Clause	Requirement - Test	Result - Remark	Verdict
	Leakage current measurements .....	(see appended table)	P
13.3	The appliance is disconnected from the supply		P
	Electric strength tests according to table 4 .....	(see appended table)	P
	No breakdown during the tests		P
14	TRANSIENT OVERVOLTAGES		--
	Appliances withstand the transient over-voltages to which they may be subjected		N/A
	Clearances having a value less than specified in table 16 subjected to an impulse voltage test, the test voltage specified in table 6 .....		N/A
	No flashover during the test, unless		N/A
	of functional insulation if the appliance complies with clause 19 with the clearance short-circuited		N/A
15	MOISTURE RESISTANCE		--
15.1	Enclosure provides the degree of moisture protection according to classification of the appliance	IPX0	N/A
	Compliance checked as specified in 15.1.1, taking into account 15.1.2, followed by the electric strength test of 16.3		N/A
	No trace of water on insulation which can result in a reduction of clearances or creepage distances below values specified in clause 29		N/A
15.1.1	Appliances, other than IPX0, subjected to tests as specified in IEC 60529 .....		N/A
	Water valves containing live parts in external hoses for connection of an appliance to the water mains tested as specified for IPX7 appliances		N/A
	The outer part of fans to be installed in the external structure is subjected to subclause 14.2.4(a) of IEC 60529. The outer part of fans is not to be installed in the external structure is protected against the water. (IEC 60335-2-80/A1)		N/A
	The fans supplied as rated voltage with shutters or similar devices being the open position. (IEC 60335-2-80/A1)		N/A
15.1.2	Hand-held appliance turned continuously through the most unfavourable positions during the test		N/A
	Built-in appliances installed according to the instructions		N/A

IEC 60335-2-80			
Clause	Requirement - Test	Result - Remark	Verdict
	Appliances placed or used on the floor or table placed on a horizontal unperforated support		N/A
	Appliances normally fixed to a wall and appliances with pins for insertion into socket-outlets are mounted on a wooden board		N/A
	For IPX3 appliances, the base of wall mounted appliances is placed at the same level as the pivot axis of the oscillating tube		N/A
	For IPX4 appliances, the horizontal centre line of the appliance is aligned with the pivot axis of the oscillating tube, and		N/A
	for appliances normally used on the floor or table, the movement is limited to two times 90° for a period of 5 min, the support being placed at the level of the pivot axis of the oscillating tube		N/A
	Wall-mounted appliances, take into account the distance to the floor stated in the instructions		N/A
	Appliances normally fixed to a ceiling are mounted underneath a horizontal unperforated support, the pivot axis of the oscillating tube located at the level of the underside of the support, and		N/A
	for IPX4 appliances, the movement of the tube is limited to two times 90° from the vertical for a period of 5 min		N/A
	Appliances with type X attachment fitted with a flexible cord as described		N/A
	Detachable parts subjected to the relevant treatment with the main part		N/A
	However, if a part has to be removed for user maintenance and a tool is needed, this part is not removed		N/A
15.2	Spillage of liquid does not affect the electrical insulation		N/A
	Appliances with type X attachment fitted with a flexible cord as described		N/A
	Appliances incorporating an appliance inlet tested with or without an connector, whichever is most unfavourable		N/A
	Detachable parts are removed		N/A
	Overfilling test with additional amount of water, over a period of 1 min (l) .....		N/A
	The appliance withstands the electric strength test of 16.3		N/A



IEC 60335-2-80			
Clause	Requirement - Test	Result - Remark	Verdict
	No trace of water on insulation that can result in a reduction of clearances or creepage distances below values specified in clause 29		N/A
15.3	Appliances proof against humid conditions		P
	Checked by test Cab: Damp heat steady state in IEC 60068-2-78		P
	Detachable parts removed and subjected, if necessary, to the humidity test with the main part		P
	Humidity test for 48 h in a humidity cabinet	25 °C, 93 % R.H.	P
	Reassembly of those parts that may have been removed		P
	The appliance withstands the tests of clause 16	(see appended table)	P
16	LEAKAGE CURRENT AND ELECTRIC STRENGTH		--
16.1	Leakage current not excessive and electric strength adequate		P
	Protective impedance disconnected from live parts before carrying out the tests		N/A
	Tests carried out at room temperature and not connected to the supply		P
16.2	Single-phase appliances: test voltage 1.06 times rated voltage (V).....:	254,4 V	P
	Three-phase appliances: test voltage 1.06 times rated voltage divided by $\sqrt{3}$ (V) .....		N/A
	Leakage current measurements .....	(see appended table)	P
	Limit values doubled if:		--
	- all controls have an off position in all poles, or		N/A
	- the appliance has no control other than a thermal cut-out, or		N/A
	- all thermostats, temperature limiters and energy regulators do not have an off position, or		N/A
	- the appliance has radio interference filters		N/A
	With the radio interference filters disconnected, the leakage current do not exceed limits specified		N/A
16.3	Electric strength tests according to table 7 .....	(see appended table)	P
	Test voltage applied between the supply cord and inlet bushing and cord guard and cord anchorage as specified		P
	No breakdown during the tests		P
17	OVERLOAD PROTECTION OF TRANSFORMERS AND ASSOCIATED CIRCUITS		--

IEC 60335-2-80			
Clause	Requirement - Test	Result - Remark	Verdict
	No excessive temperatures in transformer or associated circuits in event of short-circuits likely to occur in normal use .....		N/A
	Appliance supplied with 1.06 or 0.94 times rated voltage under the most unfavourable short-circuit or overload likely to occur in normal use (V) .....		N/A
	Basic insulation is not short-circuited		N/A
	Temperature rise of insulation of the conductors of safety extra-low voltage circuits not exceeding the relevant value specified in table 3 by more than 15 K		N/A
	Temperature of the winding not exceeding the value specified in table 8		N/A
	However, limits do not apply to fail-safe transformers complying with sub-clause 15.5 of IEC 61558-1		N/A
18	ENDURANCE		--
	Requirements and tests are specified in part 2 when necessary		N/A
19	ABNORMAL OPERATION		--
19.1	The risk of fire, mechanical damage or electric shock under abnormal or careless operation obviated		P
	Electronic circuits so designed and applied that a fault will not render the appliance unsafe		P
	Appliances incorporating heating elements subjected to the tests of 19.2 and 19.3, and		N/A
	if the appliance also has a control that limit the temperature during clause 11 it is subjected to the test of 19.4, and		N/A
	if applicable, to the test of 19.5		N/A
	Appliances incorporating PTC heating elements are also subjected to the test of 19.6		N/A
	Appliances incorporating motors subjected to the tests of 19.7 to 19.10, as applicable		P
	Appliances incorporating electronic circuits subjected to the tests of 19.11 and 19.12, as applicable		P
	Appliances incorporating contactors or relays subjected to the test of 19.14, being carried out before the tests of 19.11		N/A

IEC 60335-2-80			
Clause	Requirement - Test	Result - Remark	Verdict
	Appliances incorporating voltage selector switches subjected to the test of 19.15		N/A
	Unless otherwise specified, the tests are continued until a non-self-resetting thermal cut-out operates, or		P
	until steady conditions are established		P
	If a heating element or intentionally weak part becomes open-circuited, the relevant test is repeated on a second sample		N/A
	Fans incorporating shutters or similar subjected to the test of cl. 19.101 (IEC 60335-2-80)		N/A
19.2	Test of appliances with heating elements with restricted heat dissipation; test voltage (V), power input of 0.85 times rated power input (W) .....		N/A
19.3	Test of 19.2 repeated; test voltage (V), power input of 1.24 times rated power input (W) .....		N/A
19.4	Test conditions as in clause 11, any control limiting the temperature during tests of clause 11 short-circuited		N/A
19.5	Test of 19.4 repeated on Class 0I and I appliances with tubular sheathed or embedded heating elements. No short-circuiting, but one end of the element connected to the sheath		N/A
	The test repeated with reversed polarity and the other end of the heating element connected to the sheath		N/A
	The test is not carried out on appliances intended to be permanently connected to fixed wiring and on appliances where an all-pole disconnection occurs during the test of 19.4		N/A
19.6	Appliances with PTC heating elements tested at rated voltage, establishing steady conditions		N/A
	The working voltage of the PTC heating element is increased by 5% and the appliance is operated until steady conditions are re-established. The voltage is then increased in similar steps until 1.5 times working voltage or until the PTC heating element ruptures (V) .....		N/A
19.7	Stalling test by locking the rotor if the locked rotor torque is smaller than the full load torque, or		N/A
	locking moving parts of other appliances		P
	Locked rotor, capacitors open-circuited one at a time		P

IEC 60335-2-80			
Clause	Requirement - Test	Result - Remark	Verdict
	Test repeated with capacitors short-circuited one at a time, unless		N/A
	capacitor is of class P2 of IEC 60252-1		P
	Appliances with timer or programmer supplied with rated voltage for each of the tests, for a period equal to the maximum period allowed.....:		P
	Other appliances supplied with rated voltage for a period as specified .....	240 V	P
	Winding temperatures not exceeding values specified in table 8.....:	(see appended table)	P
	Mounting of separate control (IEC 60335-2-8)		N/A
	Approximately 50 % of the area of each ventilating opening is blocked. (IEC 60335-2-8)		N/A
	Winding temperatures not exceeding values specified in table 8 (IEC 60335-2-80)		N/A
	The temperature rise of the board not exceed: (IEC 60335-2-80)		--
	– 50 K, for appliances with T marking;		N/A
	– 65 K, for other appliances.		N/A
19.8	Multi-phase motors operated at rated voltage with one phase disconnected		N/A
19.9	Not applicable. (IEC 60335-2-80)		P
19.10	Series motor operated at 1.3 times rated voltage for 1 min (V).....:		N/A
	During the test, parts not being ejected from the appliance		N/A
19.11	Electronic circuits, compliance checked by evaluation of the fault conditions specified in 19.11.2 for all circuits or parts of circuits, unless		P
	they comply with the conditions specified in 19.11.1		P
	Appliances incorporating an electronic circuit that relies upon a programmable component to function correctly, subjected to the test of 19.11.4.8, unless	Not possible unsafe operation	N/A
	restarting does not result in a hazard		N/A
	Appliances having a device with an off position obtained by electronic disconnection, or a device placing the appliance in a stand-by mode, subjected to the tests of 19.11.4		N/A
	If the safety of the appliance under any of the fault conditions depends on the operation of a miniature fuse-link complying with IEC 60127, the test of 19.12 is carried out		P

IEC 60335-2-80			
Clause	Requirement - Test	Result - Remark	Verdict
	During and after each test the following is checked:		--
	- the temperature of the windings do not exceed the values specified in table 8		P
	- the appliance complies with the conditions specified in 19.13		P
	- any current flowing through protective impedance not exceeding the limits specified in 8.1.4		N/A
	If a conductor of a printed board becomes open-circuited, the appliance is considered to have withstood the particular test, provided both of the following conditions are met:		--
	- the base material of the printed circuit board withstands the test of Annex E		N/A
	- any loosened conductor does not reduce clearance or creepage distances between live parts and accessible metal parts below the values specified in clause 29		N/A
19.11.1	Fault conditions a) to g) in 19.11.2 are not applied to circuits or parts of circuits meeting both of the following conditions:		--
	- the electronic circuit is a low-power circuit, that is, the maximum power at low-power points does not exceed 15 W according to the tests specified	PCB for TX-1611R, after C6: 5,7 W	P
	- the protection against electric shock, fire hazard, mechanical hazard or dangerous malfunction of other parts of the appliance does not rely on the correct functioning of the electronic circuit		P
19.11.2	Fault conditions applied one at a time, the appliance operating under conditions specified in clause 11, but supplied at rated voltage, duration of the tests as specified:		--
	a) short circuit of functional insulation if clearances or creepage distances are less than the values specified in clause 29		N/A
	b) open circuit at the terminals of any component	C6: appliance stop working; R17, C7, RV: normal operation	P
	c) short circuit of capacitors, unless		N/A
	they comply with IEC 60384-14		P
	d) short circuit of any two terminals of an electronic component, other than integrated circuits	R17: normal operation; RV: fuse link operated.	P
	This fault condition is not applied between the two circuits of an optocoupler		N/A
	e) failure of triacs in the diode mode	Corresponding functions operated until steady, no hazards.	P

IEC 60335-2-80			
Clause	Requirement - Test	Result - Remark	Verdict
	f) failure of microprocessors and integrated circuits		N/A
	g) failure of an electronic power switching device		N/A
	Each low power circuit is short-circuited by connecting the low-power point to the pole of the supply source from which the measurements were made		P
19.11.3	If the appliance incorporates a protective electronic circuit which operates to ensure compliance with clause 19, the relevant test is repeated with a single fault simulated, as indicated in a) to g) of 19.11.2		N/A
19.11.4	Appliances having a device with an off position obtained by electronic disconnection, or		N/A
	a device that can be placed in the stand-by mode,		N/A
	subjected to the tests of 19.11.4.1 to 19.11.4.7, the device being set in the off position or in the stand-by mode		N/A
	Appliances incorporating a protective electronic circuit subjected to the tests of 19.11.4.1 to 19.11.4.7, the tests being carried out after the protective electronic circuit has operated, except that		N/A
	appliances operated for 30 s or 5 min during the test of 19.7 are not subjected to the tests for electromagnetic phenomena.		N/A
	Surge protective devices disconnected, unless		N/A
	They incorporate spark gaps		N/A
19.11.4.1	The appliance is subjected to electrostatic discharges in accordance with IEC 61000-4-2, test level 4		N/A
19.11.4.2	The appliance is subjected to radiated fields in accordance with IEC 61000-4-3, test level 3		N/A
19.11.4.3	The appliance is subjected to fast transient bursts in accordance with IEC 61000-4-4, test level 3 or 4 as specified		N/A
19.11.4.4	The power supply terminals of the appliance subjected to voltage surges in accordance with IEC 61000-4-5, test level 3 or 4 as specified		N/A
	Earthed heating elements in class I appliances disconnected		N/A
19.11.4.5	The appliance is subjected to injected currents in accordance with IEC 61000-4-6, test level 3		N/A

IEC 60335-2-80			
Clause	Requirement - Test	Result - Remark	Verdict
19.11.4.6	Appliances having a rated current not exceeding 16 A are subjected to the Class 3 voltage dips and interruptions in accordance with IEC 61000-4-11		N/A
	Appliances having a rated current exceeding 16 A are subjected to the Class 3 voltage dips and interruptions in accordance with IEC 61000-4-34		N/A
19.11.4.7	The appliance is subjected to mains signals in accordance with IEC 61000-4-13, test level class 2		N/A
19.11.4.8	The appliance is supplied at rated voltage and operated under normal operation. After 60s the power supply is reduced to a level such that the appliance ceases to respond or parts controlled by the programmable component cease to operate		N/A
	The appliance continues to operate normally, or		N/A
	requires a manual operation to restart		N/A
19.12	If the safety of the appliance for any of the fault conditions specified in 19.11.2 depends on the operation of a miniature fuse-link complying with IEC 60127, the test is repeated, measuring the current flowing through the fuse-link; measured current (A); rated current of the fuse-link (A).....:	Rated current: 1 A; Measured current: 20 A	P
19.13	During the tests the appliance does not emit flames, molten metal, poisonous or ignitable gas in hazardous amounts		P
	Temperature rises not exceeding the values shown in table 9.....:	(see appended table)	P
	Compliance with clause 8 not impaired		P
	If the appliance can still be operated it complies with 20.2		P
	Insulation, other than of class III appliances or class III constructions that do not contain live parts, withstands the electric strength test of 16.3, the test voltage as specified in table 4:		--
	- basic insulation (V).....:		N/A
	- supplementary insulation (V).....:		N/A
	- reinforced insulation (V).....:	3000 V	P
	After operation or interruption of a control, clearances and creepage distances across the functional insulation withstand the electric strength test of 16.3, the test voltage being twice the working voltage		P
	The appliance does not undergo a dangerous malfunction, and		P

IEC 60335-2-80			
Clause	Requirement - Test	Result - Remark	Verdict
	no failure of protective electronic circuits, if the appliance is still operable		N/A
	Appliances tested with an electronic switch in the off position, or in the stand-by mode:		N/A
	- do not become operational, or		N/A
	- if they become operational, do not result in a dangerous malfunction during or after the tests of 19.11.4		N/A
	If the appliance contains lids or doors that are controlled by one or more interlocks, one of the interlocks may be released provided that:		N/A
	- the lid or door does not move automatically to an open position when the interlock is released, and		N/A
	- the appliance does not start after the cycle in which the interlock was released		N/A
19.14	Appliances operated under the conditions of clause 11, any contactor or relay contact operating under the conditions of clause 11 being short-circuited		N/A
	For a relay or contactor with more than one contact, all contacts are short-circuited at the same time		N/A
	A relay or contactor operating only to ensure the appliance is energized for normal use is not short-circuited		N/A
	If more than one relay or contactor operates in clause 11, they are short-circuited in turn		N/A
19.15	For appliances with a mains voltage selector switch, the switch is set to the lowest rated voltage position and the highest value of rated voltage is applied		N/A
19.101	Fans incorporating shutters or similar that are operated automatically are supplied at rated voltage in the closed or open position, whichever is more unfavourable (IEC 60335-2-80)		N/A
20	STABILITY AND MECHANICAL HAZARDS		--
20.1	Appliances having adequate stability		P
	Tilting test through an angle of 10°, appliance placed on an inclined plane/horizontal support, not connected to the supply mains; appliance does not overturn		P
	Tilting test repeated on appliances with heating elements, angle of inclination increased to 15°		N/A
	Possible heating test in overturned position; temperature rise does not exceed values shown in table 9		N/A



IEC 60335-2-80			
Clause	Requirement - Test	Result - Remark	Verdict
	Portable pedestal fans exceeding 1,7 m and exceeding 10 kg tested with a force of 40 N at 1,5 m. (IEC 60335-2-80)	Not exceeding 1,7 m	N/A
20.2	Moving parts adequately arranged or enclosed as to provide protection against personal injury		P
	Protective enclosures, guards and similar parts are non-detachable, and		P
	have adequate mechanical strength		P
	Enclosures that can be opened by overriding an interlock are considered to be detachable parts		N/A
	Self-resetting thermal cut-outs and overcurrent protective devices not causing a hazard by unexpected closure		N/A
	Not possible to touch dangerous moving parts with the test probe described		P
20.101	Fan blades, other than those for mounting at high level, shall be guarded, unless: (IEC 60335-2-80)		P
	-they have a hardness less than D 60 Shore, or		N/A
	-they have a peripheral speed less than 15 m/s when the fan is supplied at rated voltage, or		N/A
	-the fan has a power output not exceeding 2 W when supplied at rated voltage.		N/A
21	MECHANICAL STRENGTH		--
21.1	Appliance has adequate mechanical strength and is constructed as to withstand rough handling		P
	Checked by applying 3 blows to every point of the enclosure like to be weak, in accordance with test Ehb of IEC 60068-2-75, spring hammer test, with an impact energy of 0,5 J		P
	The appliance shows no damage impairing compliance with this standard, and		P
	compliance with 8.1, 15.1 and clause 29 not impaired		P
	If doubt, supplementary or reinforced insulation subjected to the electric strength test of 16.3		N/A
	If necessary, repetition of groups of three blows on a new sample		N/A
21.2	Accessible parts of solid insulation having strength to prevent penetration by sharp implements		P
	Test not applicable if the thickness of supplementary insulation is at least 1 mm and reinforced insulation at least 2 mm	Plastic enclosure: 1,2 mm; Control panel: 2,4 mm	P

IEC 60335-2-80			
Clause	Requirement - Test	Result - Remark	Verdict
	The insulation is tested as specified, and does withstand the electric strength test of 16.3		N/A
21.101	Fan guards are subjected to a push and pull force of 20 N. Dangerous moving parts are not accessible (IEC 60335-2-80)		P
	The test probe is applied with a force not exceeding 5N. (IEC 60335-2-80/A2)		P
21.102	Ceiling fans have adequate strength. Load four times mass (.....) (IEC 60335-2-80)		N/A
22	CONSTRUCTION		--
22.1	Appliance marked with the first numeral of the IP system, relevant requirements of IEC 60529 are fulfilled		N/A
	NOTE 101 The enclosure defined in IEC 60529 does not include guards for fan blades. (IEC 60335-2-80)		N/A
22.2	Stationary appliance: means to ensure all-pole disconnection from the supply being provided:		--
	- a supply cord fitted with a plug, or		N/A
	- a switch complying with 24.3, or		N/A
	- a statement in the instruction sheet that a disconnection incorporated in the fixed wiring is to be provided, or		N/A
	- an appliance inlet		N/A
	Singe-pole switches and single-pole protective devices for the disconnection of heating elements in single-phase, permanently connected class 01 and class I appliances, connected to the phase conductor		N/A
22.3	Appliance provided with pins: no undue strain on socket-outlets		N/A
	Applied torque not exceeding 0.25 Nm		N/A
	Pull force of 50N to each pin after the appliance has being placed in the heating cabinet; when cooled to room temperature the pins are not displaced by more than 1mm		N/A
	Each pin subjected to a torque of 0.4Nm; the pins are not rotating, unless		N/A
	rotating does not impair compliance with this standard		N/A

IEC 60335-2-80			
Clause	Requirement - Test	Result - Remark	Verdict
22.4	Appliance for heating liquids and appliance causing undue vibration not provided with pins for insertion into socket-outlets		N/A
22.5	No risk of electric shock when touching the pins of the plug, for appliances having a capacitor with rated capacitance exceeding 0,1µF, the appliance being disconnected from the supply at the instant of voltage peak		P
	Voltage not exceeding 34 V (V)	TX-1208A: 8 V; TX-1808A: 12 V; TX-1610R: 12 V	P
22.6	Electrical insulation not affected by condensing water or leaking liquid		N/A
	Electrical insulation of Class II appliances not affected if a hose ruptures or seal leaks		N/A
	In case of doubt, test as described		N/A
22.7	Adequate safeguards against the risk of excessive pressure in appliances containing liquid or gases or having steam-producing devices		N/A
22.8	Electrical connections not subject to pulling during cleaning of compartments to which access can be gained without the aid of a tool, and that are likely to be cleaned in normal use		N/A
22.9	Insulation, internal wiring, windings, commutators and slip rings not exposed to oil, grease or similar substances, unless		P
	the substance has adequate insulating properties		N/A
22.10	Not possible to reset voltage-maintained non-self-resetting thermal cut-outs by the operation of an automatic switching device incorporated within the appliance, if:		N/A
	- a non-self-resetting thermal cut-out is required by the standard, and		N/A
	- a voltage maintained non-self-resetting thermal cut-out is used to meet it		N/A
	Non-self-resetting thermal motor protectors have a trip-free action, unless		N/A
	they are voltage maintained		N/A
	Reset buttons of non-self-resetting controls so located or protected that accidental resetting is unlikely		N/A

IEC 60335-2-80			
Clause	Requirement - Test	Result - Remark	Verdict
22.11	Reliable fixing of non-detachable parts that provide the necessary degree of protection against electric shock, moisture or contact with moving parts		P
	Obvious locked position of snap-in devices used for fixing such parts		P
	No deterioration of the fixing properties of snap-in devices used in parts that are likely to be removed during installation or servicing		P
	The 50 N force is not applied to clips used to fasten fan guards. (IEC 60335-2-80)		P
	Instead, a force of 15 N is applied in any direction to the clips in an attempt to release them. (IEC 60335-2-80)		P
	Tests as described		P
22.12	Handles, knobs etc. fixed in a reliable manner		P
	Fixing in wrong position of handles, knobs etc. indicating position of switches or similar components not possible		P
	Axial force 15 N applied to parts, the shape being so that an axial pull is unlikely to be applied		N/A
	Axial force 30 N applied to parts, the shape being so that an axial pull is likely to be applied		P
22.13	Unlikely that handles, when gripped as in normal use, make the operator's hand touch parts having a temperature rise exceeding the value specified for handles which are held for short periods only		P
22.14	No ragged or sharp edges creating a hazard for the user in normal use, or during user maintenance		P
	No exposed pointed ends of self-tapping screws or other fasteners, likely to be touched by the user in normal use or during user maintenance		P
22.15	Storage hooks and the like for flexible cords smooth and well rounded		N/A
22.16	Automatic cord reels cause no undue abrasion or damage to the sheath of the flexible cord, no breakage of conductors strands and no undue wear of contacts		N/A
	Cord reel tested with 6000 operations, as specified		N/A
	Electric strength test of 16.3, voltage of 1000 V applied		N/A
22.17	Spacers not removable from the outside by hand or by means of a screwdriver or a spanner		N/A

IEC 60335-2-80			
Clause	Requirement - Test	Result - Remark	Verdict
22.18	Current-carrying parts and other metal parts resistant to corrosion		P
22.19	Driving belts not relied upon to provide the required level of insulation, unless		N/A
	constructed to prevent inappropriate replacement		N/A
22.20	Direct contact between live parts and thermal insulation effectively prevented, unless	No thermal insulation used	N/A
	material used is non-corrosive, non-hygroscopic and non-combustible		N/A
22.21	Wood, cotton, silk, ordinary paper and fibrous or hygroscopic material not used as insulation, unless		P
	impregnated		N/A
	This requirement does not apply to magnesium oxide and mineral ceramic fibres used for the electrical insulation of heating elements	No magnesium oxide and mineral ceramic fibres used	N/A
22.22	Appliances not containing asbestos		P
22.23	Oils containing polychlorinated biphenyl (PCB) not used		P
22.24	Bare heating elements, except in class III appliances or class III constructions that do not contain live parts, adequately supported		N/A
	In case of rupture, the heating conductor is unlikely to come in contact with accessible metal parts		N/A
22.25	Sagging heating conductors, except in class III appliances or class III constructions that do not contain live parts, cannot come into contact with accessible metal parts		N/A
22.26	For class III constructions the insulation between parts operating at safety extra-low voltage and other live parts complies with the requirements for double or reinforced insulation		N/A
22.27	Parts connected by protective impedance separated by double or reinforced insulation		N/A
22.28	Metal parts of Class II appliances conductively connected to gas pipes or in contact with water, separated from live parts by double or reinforced insulation		N/A
22.29	Class II appliances permanently connected to fixed wiring so constructed that the required degree of access to live parts is maintained after installation		N/A

IEC 60335-2-80			
Clause	Requirement - Test	Result - Remark	Verdict
22.30	Parts serving as supplementary or reinforced insulation fixed so that they cannot be removed without being seriously damaged, or		N/A
	so constructed that they cannot be replaced in an incorrect position, and so that if they are omitted, the appliance is rendered inoperable or manifestly incomplete		P
22.31	Neither clearances nor creepage distances over supplementary and reinforced insulation reduced below values specified in clause 29 as a result of wear		P
	Neither clearances nor creepage distances between live parts and accessible parts reduced below values for supplementary insulation if wires, screws etc. become loose		P
22.32	Supplementary and reinforced insulation constructed or protected against pollution so that clearances or creepage distances are not reduced below the values in clause 29		P
	Supplementary insulation of natural or synthetic rubber resistant to ageing, or arranged and dimensioned so that creepage distances are not reduced below values specified in 29.2		N/A
	Ceramic material not tightly sintered, similar materials or beads alone not used as supplementary or reinforced insulation		N/A
	Insulating material in which heating conductors are embedded is considered to be basic insulation, not reinforced insulation		N/A
	Oxygen bomb test at 70 °C for 96 h and 16 h at room temperature		N/A
22.33	Conductive liquids that are or may become accessible in normal use and conductive liquids that are in contact with unearthed accessible metal parts are not in direct contact with live parts		N/A
	Electrodes not used for heating liquids		N/A
	For class II constructions, conductive liquids that are or may become accessible in normal use and conductive liquids that are in contact with unearthed accessible metal parts, not in direct contact with basic or reinforced insulation, unless		N/A
	the reinforced insulation consists of at least 3 layers		N/A

IEC 60335-2-80			
Clause	Requirement - Test	Result - Remark	Verdict
	For class II constructions, conductive liquids which are in contact with live parts, not in direct contact with reinforced insulation, unless		N/A
	the reinforced insulation consists of at least 3 layers		N/A
	An air layer not used as basic or supplementary insulation in a double insulation system if likely to be bridged by leaking liquid		N/A
22.34	Shafts of operating knobs, handles, levers etc. not live, unless		P
	the shaft is not accessible when the part is removed		N/A
22.35	For other than class III constructions, handles, levers and knobs, held or actuated in normal use, not becoming live in the event of a failure of basic insulation		P
	Such parts being of metal, and their shafts or fixings are likely to become live in the event of a failure of basic insulation, are either adequately covered by insulation material or their accessible parts are separated from their shafts or fixings by supplementary insulation		N/A
	This requirement does not apply to handles, levers and knobs on stationary appliances, other than those of electrical components, provided they are reliably connected to an earthing terminal or earthing contact, or separated from live parts by earthed metal		N/A
	Insulating material covering metal handles, levers and knobs withstand the electric strength test of 16.3 for supplementary insulation		N/A
22.36	For appliances other than class III, handles continuously held in the hand in normal use so constructed that when gripped as in normal use, the operators hand is not likely to touch metal parts, unless		N/A
	they are separated from live parts by double or reinforced insulation		N/A
22.37	Capacitors in Class II appliances not connected to accessible metal parts and their casings, if of metal, separated from accessible metal parts by supplementary insulation, unless		P
	the capacitors comply with 22.42		N/A
22.38	Capacitors not connected between the contacts of a thermal cut-out		P

IEC 60335-2-80			
Clause	Requirement - Test	Result - Remark	Verdict
22.39	Lamp holders used only for the connection of lamps		N/A
22.40	Motor-operated appliances and combined appliances intended to be moved while in operation, or having accessible moving parts, fitted with a switch to control the motor. The actuating member of the switch being easily visible and accessible	Not intended to be moved while in operation; Have no accessible moving parts	N/A
	If the appliance cannot operate continuously, automatically or remotely without giving rise to a hazard, appliances for remote operation being fitted with a switch for stopping the operation. The actuating member of the switch being easily visible and accessible		N/A
22.41	No components, other than lamps, containing mercury		N/A
22.42	Protective impedance consisting of at least two separate components		N/A
	Values specified in 8.1.4 not exceeded if any one of the components are short-circuited or open-circuited		N/A
	Resistors checked by the test of 14.1 a) in IEC 60065		N/A
	Capacitors checked by the tests for class Y capacitors in IEC 60384-14		N/A
22.43	Appliances adjustable for different voltages, accidental changing of the setting of the voltage unlikely to occur		N/A
22.44	Appliances not having an enclosure that is shaped or decorated like a toy		P
22.45	When air is used as reinforced insulation, clearances not reduced below the values specified in 29.1.3 due to deformation as a result of an external force applied to the enclosure		P
22.46	For programmable protective electronic circuits used to ensure compliance with the standard, the software contains measures to control the fault/error conditions in table R.1		N/A
	Software that contains measures to control the fault/error conditions specified in table R.2 is to be specified in parts 2 for particular constructions or to address specific hazards		N/A
	These requirements are not applicable to software used for functional purpose or compliance with clause 11		N/A



IEC 60335-2-80			
Clause	Requirement - Test	Result - Remark	Verdict
22.47	Appliances connected to the water mains withstand the water pressure expected in normal use		N/A
	No leakage from any part, including any inlet water hose		N/A
22.48	Appliances connected to the water mains constructed to prevent backsiphonage of non-potable water		N/A
22.49	For remote operation, the duration of operation is to be set before the appliance can be started, unless		N/A
	the appliance switches off automatically or can operate continuously without hazard		N/A
22.50	Controls incorporated in the appliance take priority over controls actuated by remote operation		N/A
22.51	There is a control on the appliance manually adjusted to the setting for remote operation before the appliance can be operated in this mode		N/A
	There is a visual indication showing that the appliance is adjusted for remote operation		N/A
	These requirements not necessary on appliances that can operate as follows, without giving rise to a hazard:		--
	- continuously, or		N/A
	- automatically, or		N/A
	- remotely		N/A
22.52	Socket-outlets on appliances accessible to the user in accordance with the socket-outlet system used in the country in which the appliance is sold		N/A
22.101	Appliances having provision for attaching a luminaire incorporate appropriate terminals and internal wiring. (IEC 60335-2-80)		N/A
23	INTERNAL WIRING		--
23.1	Wireways smooth and free from sharp edges		P
	Wires protected against contact with burrs, cooling fins etc.		P
	Wire holes in metal well-rounded or provided with bushings		N/A
	Wiring effectively prevented from coming into contact with moving parts		P
23.2	Beads etc. on live wires cannot change their position, and are not resting on sharp edges	No such structure	N/A

IEC 60335-2-80			
Clause	Requirement - Test	Result - Remark	Verdict
	Beads inside flexible metal conduits contained within an insulating sleeve		N/A
23.3	Electrical connections and internal conductors movable relatively to each other not exposed to undue stress		P
	Flexible metallic tubes not causing damage to insulation of conductors		N/A
	Open-coil springs not used		P
	Adequate insulating lining provided inside a coiled spring, the turns of which touch one another		N/A
	No damage after 100 000 flexings for conductors flexed during normal use and at rated voltage, or (IEC 60335-2-80)		P
	100 flexings for conductors flexed during user maintenance		P
	Electric strength test of 16.3, 1000 V between live parts and accessible metal parts		P
	Not more than 10% of the strands of any conductor broken, and		P
	not more than 30% for wiring supplying circuits that consume no more than 15W		N/A
23.4	Bare internal wiring sufficiently rigid and fixed	No bare internal wiring used	N/A
23.5	The insulation of internal wiring subjected to the supply mains voltage withstanding the electrical stress likely to occur in normal use		P
	Basic insulation electrically equivalent to the basic insulation of cords complying with IEC 60227 or IEC 60245, or		N/A
	no breakdown when a voltage of 2000 V is applied for 15 min between the conductor and metal foil wrapped around the insulation		P
23.6	Sleeving used as supplementary insulation on internal wiring retained in position by clamping at both ends, or		P
	be such that it can only be removed by breaking or cutting		N/A
23.7	The colour combination green/yellow only used for earthing conductors		N/A
23.8	Aluminium wires not used for internal wiring	No aluminium wires used	N/A
23.9	Stranded conductors not consolidated by soldering where they are subjected to contact pressure, unless		P

IEC 60335-2-80			
Clause	Requirement - Test	Result - Remark	Verdict
	the contact pressure is provided by spring terminals		N/A
23.10	The insulation and sheath of internal wiring, incorporated in external hoses for the connection of an appliance to the water mains, at least equivalent to that of light polyvinyl chloride sheathed flexible cord (60227 IEC 52)		N/A
24	COMPONENTS		--
24.1	Components comply with safety requirements in relevant IEC standards		P
	List of components .....	(see appended table)	P
	If components have not been tested and found to comply with relevant IEC standard for the number of cycles specified, they are tested in accordance with 24.1.1 to 24.1.9		N/A
	For components mentioned in 24.1.1 to 24.1.9 no additional tests specified in the relevant component standard are necessary other than those specified in 24.1.1 to 24.1.9		P
	Components not tested and found to comply with relevant IEC standard and components not marked or not used in accordance with its marking, tested under the conditions occurring in the appliance		P
	Lampholders and starterholders that have not being tested and found to comply with the relevant IEC standard, tested as a part of the appliance and additionally according to the gauging and interchangeability requirements of the relevant IEC standard		N/A
	No additional tests specified for nationally standardized plugs such as those detailed in IEC/TR 60083 or connectors complying with the standard sheets of IEC 60320-1 and IEC 60309		P
24.1.1	Capacitors likely to be permanently subjected to the supply voltage and used for radio interference suppression or for voltage dividing, complying with IEC 60384-14		P
	If the capacitors have to be tested, they are tested according to Annex F		N/A
24.1.2	Safety isolating transformers complying with IEC 61558-2-6		N/A
	If they have to be tested, they are tested according to Annex G		N/A
24.1.3	Switches complying with IEC 61058-1, the number of cycles of operation being at least 10 000		P

IEC 60335-2-80			
Clause	Requirement - Test	Result - Remark	Verdict
	If they have to be tested, they are tested according to Annex H		N/A
	If the switch operates a relay or contactor, the complete switching system is subjected to the test		N/A
	If the switch only operates a motor starting relay complying with IEC 60730-2-10 with the number of cycles of a least 10 000 as specified, the complete switching system need not be tested		N/A
24.1.4	Automatic controls complying with IEC 60730-1 with the relevant part 2. The number of cycles of operation being at least:		--
	- thermostats: 10 000		N/A
	- temperature limiters: 1 000		N/A
	- self-resetting thermal cut-outs: 300		N/A
	- voltage maintained non-self-resetting thermal cut-outs: 1 000		N/A
	- other non-self-resetting thermal cut-outs: 30		N/A
	- timers: 3 000		P
	- energy regulators: 10 000		N/A
	The number of cycles for controls operating during clause 11 need not be declared, if the appliance meets the requirements of this standard when they are short-circuited		N/A
	Thermal motor protectors are tested in combination with their motor under the conditions specified in Annex D		N/A
	For water valves containing live parts and that are incorporated in external hoses for connection of an appliance to the water mains, the degree of protection declared for subclause 6.5.2 of IEC 60730-2-8 is IPX7		N/A
24.1.5	Appliance couplers complying with IEC 60320-1		N/A
	However, for appliances classified higher than IPX0, the appliance couplers complying with IEC 60320-2-3		N/A
	Interconnection couplers complying with IEC 60320-2-2		N/A
24.1.6	Small lamp holders similar to E10 lampholders complying with IEC 60238, the requirements for E10 lampholders being applicable		N/A

IEC 60335-2-80			
Clause	Requirement - Test	Result - Remark	Verdict
24.1.7	For remote operation of the appliance via a telecommunication network, the relevant standard for the telecommunication interface circuitry in the appliance is IEC 62151		N/A
24.1.8	The relevant standard for thermal links is IEC 60691		P
	Thermal links not complying with IEC 60691 are considered to be an intentionally weak part for the purposes of Clause 19		N/A
24.1.9	Contactors and relays, other than motor starting relays, tested as part of the appliance		N/A
	They are also tested in accordance with Clause 17 of IEC 60730-1, the number of cycles of operations in 24.1.4 selected according to the contactor or relay function in the appliance		N/A
24.2	Appliances not fitted with:		--
	- switches or automatic controls in flexible cords		P
	- devices causing the protective device in the fixed wiring to operate in the event of a fault in the appliance		P
	- thermal cut-outs that can be reset by soldering, unless		P
	the solder has a melting point of at least 230 °C		N/A
	Switches or automatic controls in flexible cords are allowed for appliances not exceeding 25 W. (IEC 60335-2-80)		N/A
24.3	Switches intended for all-pole disconnection of stationary appliances are directly connected to the supply terminals and have a contact separation in all poles, providing full disconnection under overvoltage category III conditions		N/A
24.4	Plugs and socket-outlets for extra-low voltage circuits and heating elements, not interchangeable with plugs and socket-outlets listed in IEC/TR 60083 or IEC 60906-1 or with connectors and appliance inlets complying with the standard sheets of IEC 60320-1		N/A
24.5	Capacitors in auxiliary windings of motors marked with their rated voltage and capacitance, and used accordingly		P

IEC 60335-2-80			
Clause	Requirement - Test	Result - Remark	Verdict
	Voltage across capacitors in series with a motor winding does not exceed 1,1 times rated voltage, when the appliance is supplied at 1,1 times rated voltage under minimum load	Rated voltage of motor capacitor: 450 V; Measure voltage: TX-1208A: 370,6 V; TX-1808A: 390,3 V; TX-1610R: 362,2 V (Limit: 495 V)	P
24.6	Working voltage of motors connected to the supply mains and having basic insulation that is inadequate for the rated voltage of the appliance, not exceeding 42 V		N/A
	In addition, the motors comply with the requirements of Annex I		N/A
24.7	Detachable hose-sets for connection of appliances to the water mains comply with IEC 61770		N/A
	They are supplied with the appliance		N/A
	Appliances intended to be permanently connected to the water mains not connected by a detachable hose-set		N/A
24.8	Motor running capacitors in appliances for which 30.2.3 is applicable and that are permanently connected in series with a motor winding, not causing a hazard in event of a failure		P
	One or more of the following conditions are to be met:		--
	- the capacitors are of class P2 according to IEC 60252-1		P
	- the capacitors are housed within a metallic or ceramic enclosure		N/A
	- the distance of separation of the outer surface to adjacent non-metallic parts exceeds 50 mm		N/A
	- adjacent non-metallic parts within 50 mm withstand the needle-flame test of Annex E		N/A
	- adjacent non-metallic parts within 50 mm classified as at least V-1 according to IEC 60695-11-10		N/A
24.101	Thermal cut-outs in duct fans in order to comply with cl. 19 are not self-resetting (IEC 60335-2-80)		N/A
25	SUPPLY CONNECTION AND EXTERNAL FLEXIBLE CORDS		--
25.1	Appliance not intended for permanent connection to fixed wiring, means for connection to the supply:		P
	- supply cord fitted with a plug,		P

IEC 60335-2-80			
Clause	Requirement - Test	Result - Remark	Verdict
	- an appliance inlet having at least the same degree of protection against moisture as required for the appliance, or		N/A
	- pins for insertion into socket-outlets		N/A
25.2	Appliance not provided with more than one means of connection to the supply mains		P
	Stationary appliance for multiple supply may be provided with more than one means of connection, provided electric strength test of 1250 V for 1 min between each means of connection causes no breakdown		N/A
25.3	Appliance intended to be permanently connected to fixed wiring provided with one of the following means for connection to the supply mains:		--
	- a set of terminals allowing the connection of a flexible cord		N/A
	- a fitted supply cord		N/A
	- a set of supply leads accommodated in a suitable compartment		N/A
	- a set of terminals for the connection of cables of fixed wiring, cross-sectional areas specified in 26.6, and the appliance allows the connection of the supply conductors after the appliance has been fixed to its support		N/A
	- a set of terminals and cable entries, conduit entries, knock-outs or glands, allowing connection of appropriate types of cable or conduit, and the appliance allows the connection of the supply conductors after the appliance has been fixed to its support		N/A
	For a fixed appliance constructed so that parts can be removed to facilitate easy installation, this requirement is met if it is possible to connect the fixed wiring without difficulty after a part of the appliance has been fixed to its support		N/A
25.4	Cable and conduit entries, rated current of appliance not exceeding 16 A, dimension according to table 10 (mm) .....		N/A
	Introduction of conduit or cable does not reduce clearances or creepage distances below values specified in clause 29		N/A
25.5	Method for assembling the supply cord to the appliance:		--
	- type X attachment		N/A
	- type Y attachment		P

IEC 60335-2-80			
Clause	Requirement - Test	Result - Remark	Verdict
	- type Z attachment, if allowed in relevant part 2		N/A
	Type X attachment, other than those with a specially prepared cord, not used for flat twin tinsel cords		N/A
	For multi-phase appliances supplied with a supply cord and that are intended to be permanently connected to fixed wiring, the supply cord is assembled to the appliance by type Y attachment		N/A
	- type Z attachment is allowed for portable fans (IEC 60335-2-80)		N/A
25.6	Plugs fitted with only one flexible cord		P
25.7	Supply cords, other than for class III appliances, being one of the following types:		--
	- rubber sheathed (at least 60245 IEC 53)		N/A
	- polychloroprene sheathed (at least 60245 IEC 57)		N/A
	- cross-linked polyvinyl chloride sheathed (at least 60245 IEC 88)		N/A
	- polyvinyl chloride sheathed. Not used if they are likely to touch metal parts having a temperature rise exceeding 75 K during the test of clause 11		--
	<ul style="list-style-type: none"> <li>light polyvinyl chloride sheathed cord (60227 IEC 52), for appliances not exceeding 3 kg</li> </ul>	H03VVH2-F	P
	<ul style="list-style-type: none"> <li>ordinary polyvinyl chloride sheathed cord (60227 IEC 53), for other appliances</li> </ul>	H05VVH2-F	P
	- heat resistant polyvinyl chloride sheathed. Not used for type X attachment other than specially prepared cords		--
	<ul style="list-style-type: none"> <li>heat-resistant light polyvinyl chloride sheathed cord (60227 IEC 56), for appliances not exceeding 3 kg</li> </ul>		N/A
	<ul style="list-style-type: none"> <li>heat-resistant polyvinyl chloride sheathed cord (60227 IEC 57), for other appliances</li> </ul>		N/A
	Supply cords for class III appliances adequately insulated		N/A
	Test with 500 V for 2 min for supply cords of class III appliances that contain live parts		N/A
25.8	Nominal cross-sectional area of supply cords not less than table 11; rated current (A); cross-sectional area (mm <sup>2</sup> ).....:	TX-1208A: 0,127 A; TX-1808A: 0,293 A; TX-1610R: 0,246 A; 0,5 mm <sup>2</sup> or 0,75 mm <sup>2</sup>	P
25.9	Supply cords not in contact with sharp points or edges		P



IEC 60335-2-80			
Clause	Requirement - Test	Result - Remark	Verdict
25.10	Supply cord of class I appliances have a green/yellow core for earthing		N/A
25.11	Conductors of supply cords not consolidated by soldering where they are subject to contact pressure, unless		P
	the contact pressure is provided by spring terminals		N/A
25.12	Insulation of the supply cord not damaged when moulding the cord to part of the enclosure		N/A
25.13	Inlet openings so constructed as to prevent damage to the supply cord		P
	If the enclosure at the inlet opening is not of insulating material, a non-detachable lining or bushing complying with 29.3 for supplementary insulation provided	inlet opening is of insulating material	N/A
	If unsheathed supply cord, a similar additional bushing or lining is required, unless the appliance is		N/A
	class 0, or		N/A
	a class III appliance not containing live parts		N/A
25.14	Supply cords moved while in operation adequately protected against excessive flexing		N/A
	Flexing test, as described:		N/A
	- applied force (N).....:		N/A
	- number of flexings.....:		N/A
	The test does not result in:		N/A
	- short-circuit between the conductors, such that the current exceeds a value of twice the rated current		N/A
	- breakage of more than 10% of the strands of any conductor		N/A
	- separation of the conductor from its terminal		N/A
	- loosening of any cord guard		N/A
	- damage to the cord or the cord guard		N/A
	- broken strands piercing the insulation and becoming accessible		N/A
25.15	For appliances with supply cord and appliances to be permanently connected to fixed wiring by a flexible cord, conductors of the supply cord relieved from strain, twisting and abrasion by use of cord anchorage		P

IEC 60335-2-80			
Clause	Requirement - Test	Result - Remark	Verdict
	The cord cannot be pushed into the appliance to such an extent that the cord or internal parts of the appliance can be damaged		P
	Pull and torque test of supply cord, values shown in table 12: mass (kg); pull (N); torque (not on automatic cord reel) (Nm).....:	For TX1208A: pull force: 60 N, 0,25 Nm; For TX-1808A and TX-1610R: pull force: 100 N, 0,35 Nm	P
	Cord not damaged and max. 2 mm displacement of the cord	0,8 mm	P
25.16	Cord anchorages for type X attachments constructed and located so that:		--
	- replacement of the cord is easily possible		N/A
	- it is clear how the relief from strain and the prevention of twisting are obtained		N/A
	- they are suitable for different types of supply cord		N/A
	- cord cannot touch the clamping screws of cord anchorage if these screws are accessible, unless		N/A
	they are separated from accessible metal parts by supplementary insulation		N/A
	- the cord is not clamped by a metal screw which bears directly on the cord		N/A
	- at least one part of the cord anchorage securely fixed to the appliance, unless		N/A
	it is part of a specially prepared cord		N/A
	- screws which have to be operated when replacing the cord do not fix any other component, unless		N/A
	the appliance becomes inoperative or incomplete or the parts cannot be removed without a tool		N/A
	- if labyrinths can be bypassed the test of 25.15 is nevertheless withstood		N/A
	- for class 0, 0I and I appliances they are of insulating material or are provided with an insulating lining, unless		N/A
	failure of the insulation of the cord does not make accessible metal parts live		N/A
	- for class II appliances they are of insulating material, or		N/A
	if of metal, they are insulated from accessible metal parts by supplementary insulation		N/A
	After the test of 25.15, under the conditions specified, the conductors have not moved by more than 1 mm in the terminals		N/A

IEC 60335-2-80			
Clause	Requirement - Test	Result - Remark	Verdict
25.17	Adequate cord anchorages for type Y and Z attachment, test with the cord supplied with the appliance	For type Y	P
25.18	Cord anchorages only accessible with the aid of a tool, or		P
	Constructed so that the cord can only be fitted with the aid of a tool		P
25.19	Type X attachment, glands not used as cord anchorage in portable appliances		N/A
	Tying the cord into a knot or tying the cord with string not used		N/A
25.20	The insulated conductors of the supply cord for type Y and Z attachment additionally insulated from accessible metal parts		N/A
25.21	Space for supply cord for type X attachment or for connection of fixed wiring constructed:		--
	- to permit checking of conductors with respect to correct positioning and connection before fitting any cover		N/A
	- so there is no risk of damage to the conductors or their insulation when fitting the cover		N/A
	- for portable appliances, so that the uninsulated end of a conductor, if it becomes free from the terminal, prevented from contact with accessible metal parts		N/A
	2 N test to the conductor for portable appliances; no contact with accessible metal parts		N/A
25.22	Appliance inlets:		--
	- live parts not accessible during insertion or removal		N/A
	Requirement not applicable to appliance inlets complying with IEC 60320-1		N/A
	- connector can be inserted without difficulty		N/A
	- the appliance is not supported by the connector		N/A
	- not for cold conditions if temp. rise of external metal parts exceeds 75 K during clause 11, unless		N/A
	the supply cord is unlikely to touch such metal parts		N/A
25.23	Interconnection cords comply with the requirements for the supply cord, except that:		N/A

IEC 60335-2-80			
Clause	Requirement - Test	Result - Remark	Verdict
	- the cross-sectional area of the conductors is determined on the basis of the maximum current during clause 11		N/A
	- the thickness of the insulation may be reduced		N/A
	If necessary, electric strength test of 16.3		N/A
25.24	Interconnection cords not detachable without the aid of a tool if compliance with this standard is impaired when they are disconnected		N/A
25.25	Dimensions of pins that are inserted into socket-outlets compatible with the dimensions of the relevant socket-outlet.		N/A
	Dimensions of pins and engagement face in accordance with the dimensions of the relevant plug in IEC/TR 60083		N/A
26	TERMINALS FOR EXTERNAL CONDUCTORS		--
26.1	Appliances provided with terminals or equally effective devices for connection of external conductors		P
	Terminals only accessible after removal of a non-detachable cover, except		P
	for class III appliances that do not contain live parts		N/A
	Earthing terminals may be accessible if a tool is required to make the connections and means are provided to clamp the wire independently from its connection		N/A
26.2	Appliances with type X attachment and appliances for the connection of cables to fixed wiring provided with terminals in which connections are made by means of screws, nuts or similar devices, unless		N/A
	the connections are soldered		N/A
	Screws and nuts not used to fix any other component, except		N/A
	internal conductors, if so arranged that they are unlikely to be displaced when fitting the supply conductors		N/A
	If soldered connections used, the conductor so positioned or fixed that reliance is not placed on soldering alone, unless		N/A
	barriers provided so that neither clearances nor creepage distances between live parts and other metal parts reduced below the values for supplementary insulation if the conductor becomes free at the soldered joint		N/A

IEC 60335-2-80			
Clause	Requirement - Test	Result - Remark	Verdict
26.3	Terminals for type X attachment and for connection of cables of fixed wiring so constructed that the conductor is clamped between metal surfaces with sufficient contact pressure but without damaging the conductor		N/A
	Terminals fixed so that when the clamping means is tightened or loosened:		N/A
	- the terminal does not become loose		N/A
	- internal wiring is not subjected to stress		N/A
	- neither clearances nor creepage distances are reduced below the values in clause 29		N/A
	Compliance checked by inspection and by the test of subclause 9.6 of IEC 60999-1, the torque applied being equal to two-thirds of the torque specified (Nm).....:		N/A
	No deep or sharp indentations of the conductors		N/A
26.4	Terminals for type X attachment, except those having a specially prepared cord and those for the connection of cables of fixed wiring, no special preparation of conductors such as by soldering, use of cable lugs, eyelets or similar, and		N/A
	so constructed or placed that conductors prevented from slipping out when clamping screws or nuts are tightened		N/A
26.5	Terminals for type X attachment so located or shielded that if a wire of a stranded conductor escapes, no risk of accidental connection to other parts that result in a hazard		N/A
	Stranded conductor test, 8 mm insulation removed		N/A
	No contact between live parts and accessible metal parts and,		N/A
	for class II constructions, between live parts and metal parts separated from accessible metal parts by supplementary insulation only		N/A
26.6	Terminals for type X attachment and for connection of cables of fixed wiring suitable for connection of conductors with cross-sectional area according to table 13; rated current (A); nominal cross-sectional area (mm <sup>2</sup> ).....:		N/A
	If a specially prepared cord is used, terminals need only be suitable for that cord		N/A
26.7	Terminals for type X attachment, except in class III appliances not containing live parts, accessible after removal of a cover or part of the enclosure		N/A

IEC 60335-2-80			
Clause	Requirement - Test	Result - Remark	Verdict
26.8	Terminals for the connection of fixed wiring, including the earthing terminal, located close to each other		N/A
26.9	Terminals of the pillar type constructed and located as specified		N/A
26.10	Terminals with screw clamping and screwless terminals not used for flat twin tinsel cords, unless		N/A
	conductors ends fitted with means suitable for screw terminals		N/A
	Pull test of 5 N to the connection		N/A
26.11	For type Y and Z attachment, soldered, welded, crimped or similar connections may be used		P
	For Class II appliances, the conductor so positioned or fixed that reliance is not placed on soldering, welding or crimping alone		P
	If soldering, welding or crimping alone used, barriers provided so that clearances and creepage distances between live parts and other metal parts are not reduced below the values for supplementary insulation if the conductor becomes free		N/A
27	PROVISION FOR EARTHING		--
27.1	Accessible metal parts of Class 0I and I appliances permanently and reliably connected to an earthing terminal or earthing contact of the appliance inlet		N/A
	Earthing terminals and earthing contacts not connected to the neutral terminal		N/A
	Class 0, II and III appliances have no provision for earthing	Class II	P
	Safety extra-low voltage circuits not earthed, unless		N/A
	protective extra-low voltage circuits		N/A
27.2	Clamping means of earthing terminals adequately secured against accidental loosening		N/A
	Terminals for the connection of external equipotential bonding conductors allow connection of conductors of 2.5 to 6 mm <sup>2</sup> , and		N/A
	do not provide earthing continuity between different parts of the appliance, and		N/A
	conductors cannot be loosened without the aid of a tool		N/A

IEC 60335-2-80			
Clause	Requirement - Test	Result - Remark	Verdict
27.3	For a detachable part having an earth connection and being plugged into another part of the appliance, the earth connection is made before and separated after current-carrying connections when removing the part		N/A
	For appliances with supply cords, current-carrying conductors become taut before earthing conductor, if the cord slips out of the cord anchorage		N/A
27.4	No risk of corrosion resulting from contact between parts of the earthing terminal and the copper of the earthing conductor or other metal		N/A
	Parts providing earthing continuity, other than parts of a metal frame or enclosure, have adequate resistance to corrosion		N/A
	If of steel, these parts provided with an electroplated coating with a thickness at least 5 µm		N/A
	Adequate protection against rusting of parts of coated or uncoated steel, only intended to provide or transmit contact pressure		N/A
	In the body of the earthing terminal is a part of a frame or enclosure of aluminium or aluminium alloys, precautions taken to avoid risk of corrosion		N/A
27.5	Low resistance of connection between earthing terminal and earthed metal parts		N/A
	This requirement does not apply to connections providing earthing continuity in the protective extra-low voltage circuit, provided the clearances of basic insulation are based on the rated voltage of the appliance		N/A
	Resistance not exceeding 0,1 Ω at the specified low-resistance test (Ω ) .....		N/A
27.6	The printed conductors of printed circuit boards not used to provide earthing continuity in hand-held appliances.		N/A
	They may be used to provide earthing continuity in other appliances if at least two tracks are used with independent soldering points and the appliance complies with 27.5 for each circuit		N/A
28	SCREWS AND CONNECTIONS		--
28.1	Fixings, electrical connections and connections providing earthing continuity withstand mechanical stresses		P
	Screws not of soft metal liable to creep, such as zinc or aluminium		P

IEC 60335-2-80			
Clause	Requirement - Test	Result - Remark	Verdict
	Diameter of screws of insulating material min. 3 mm		N/A
	Screws of insulating material not used for any electrical connections or connections providing earthing continuity	No screws of insulating material used	N/A
	Screws used for electrical connections or connections providing earthing continuity screwed into metal		N/A
	Screws not of insulating material if their replacement by a metal screw can impair supplementary or reinforced insulation		N/A
	For type X attachment, screws to be removed for replacement of supply cord or for user maintenance, not of insulating material if their replacement by a metal screw impairs basic insulation		N/A
	For screws and nuts; torque-test as specified in table 14.....:		N/A
28.2	Electrical connections and connections providing earthing continuity constructed so that contact pressure is not transmitted through non-ceramic insulating material liable to shrink or distort, unless		P
	there is resiliency in the metallic parts to compensate for shrinkage or distortion of the insulating material		N/A
	This requirement does not apply to electrical connections in circuits of appliances for which:		N/A
	<ul style="list-style-type: none"> <li>30.2.2 is applicable and that carry a current not exceeding 0,5 A</li> </ul>		N/A
	<ul style="list-style-type: none"> <li>30.2.3 is applicable and that carry a current not exceeding 0,2 A</li> </ul>		N/A
28.3	Space-threaded (sheet metal) screws only used for electrical connections if they clamp the parts together		N/A
	Thread-cutting (self-tapping) screws and thread rolling screws only used for electrical connections if they generate a full form standard machine screw thread		N/A
	Thread-cutting (self-tapping) screws not used if they are likely to be operated by the user or installer		N/A
	Thread-cutting, thread rolling and space threaded screws may be used in connections providing earthing continuity provided it is not necessary to disturb the connection:		N/A



IEC 60335-2-80			
Clause	Requirement - Test	Result - Remark	Verdict
	- in normal use,		N/A
	- during user maintenance,		N/A
	- when replacing a supply cord having a type X attachment, or		N/A
	- during installation		N/A
	At least two screws being used for each connection providing earthing continuity, unless		N/A
	the screw forms a thread having a length of at least half the diameter of the screw		N/A
28.4	Screws and nuts that make mechanical connection secured against loosening if they also make electrical connections or connections providing earthing continuity		N/A
	This requirement does not apply to screws in the earthing circuit if at least two screws are used, or		N/A
	if an alternative earthing circuit is provided		N/A
	Rivets for electrical connections or connections providing earthing continuity secured against loosening if the connections are subjected to torsion		N/A
29	CLEARANCES, CREEPAGE DISTANCES AND SOLID INSULATION		--
	Clearances, creepage distances and solid insulation withstand electrical stress		P
	For coatings used on printed circuits boards to protect the microenvironment (Type 1) or to provide basic insulation (Type 2), Annex J applies.....:		N/A
	The microenvironment is pollution degree 1 under type 1 protection		N/A
	For type 2 protection, the spacing between the conductors before the protection is applied is not less than the values specified in Table 1 of IEC 60664-3		N/A
	These values apply to functional, basic, supplementary and reinforced insulation .....		N/A
29.1	Clearances not less than the values specified in table 16, taking into account the rated impulse voltage for the overvoltage categories of table 15, unless .....	(see appended table)	P
	for basic insulation and functional insulation they comply with the impulse voltage test of clause 14		N/A

IEC 60335-2-80			
Clause	Requirement - Test	Result - Remark	Verdict
	However, if the distances are affected by wear, distortion, movement of the parts or during assembly, the clearances for rated impulse voltages of 1500V and above are increased by 0,5 mm and the impulse voltage test is not applicable		P
	Impulse voltage test is not applicable:		--
	- when the microenvironment is pollution degree 3, or		P
	- for basic insulation of class 0 and class 01 appliances		N/A
	Appliances are in overvoltage category II		P
	A force of 2 N is applied to bare conductors, other than heating elements		P
	A force of 30 N is applied to accessible surfaces		P
29.1.1	Clearances of basic insulation withstand the overvoltages, taking into account the rated impulse voltage		P
	The values of table 16 or the impulse voltage test of clause 14 are applicable.....:	(see appended table)	P
	Clearance at the terminals of tubular sheathed heating elements may be reduced to 1,0 mm if the microenvironment is pollution degree 1		N/A
	Lacquered conductors of windings considered to be bare conductors		P
29.1.2	Clearances of supplementary insulation not less than those specified for basic insulation in table 16:	(see appended table)	P
29.1.3	Clearances of reinforced insulation not less than those specified for basic insulation in table 16, using the next higher step for rated impulse voltage.....:	(see appended table)	P
	For double insulation, with no intermediate conductive part between basic and supplementary insulation, clearances are measured between live parts and the accessible surface, and the insulation system is treated as reinforced insulation		P
29.1.4	Clearances for functional insulation are the largest values determined from:		--
	- table 16 based on the rated impulse voltage.....:	(see appended table)	P
	- table F.7a in IEC 60664-1, frequency not exceeding 30 kHz		N/A
	- clause 4 of IEC 60664-4, frequency exceeding 30 kHz		N/A

IEC 60335-2-80			
Clause	Requirement - Test	Result - Remark	Verdict
	If values of table 16 are largest, the impulse voltage test of clause 14 may be applied instead, unless		N/A
	the microenvironment is pollution degree 3, or		P
	the distances can be affected by wear, distortion, movement of the parts or during assembly		P
	However, clearances are not specified if the appliance complies with clause 19 with the functional insulation short-circuited		P
	Lacquered conductors of windings considered to be bare conductors		P
	However, clearances at crossover points are not measured		P
	Clearance between surfaces of PTC heating elements may be reduced to 1mm		N/A
29.1.5	Appliances having higher working voltages than rated voltage, clearances for basic insulation are the largest values determined from:		--
	- table 16 based on the rated impulse voltage .....		P
	- table F.7a in IEC 60664-1, frequency not exceeding 30 kHz		N/A
	- clause 4 of IEC 60664-4, frequency exceeding 30 kHz		N/A
	If clearances for basic insulation are selected from Table F.7a of IEC 60664-1 or Clause 4 of IEC 60664-4, the clearances of supplementary insulation are not less than those specified for basic insulation		N/A
	If clearances for basic insulation are selected from Table F.7a of IEC 60664-1, the clearances of reinforced insulation dimensioned as specified in Table F.7a are to withstand 160% of the withstand voltage required for basic insulation		N/A
	If clearances for basic insulation are selected from Clause 4 of IEC 60664-4, the clearances of reinforced insulation are twice the value required for basic insulation		N/A
	If the secondary winding of a step-down transformer is earthed, or if there is an earthed screen between the primary and secondary windings, clearances of basic insulation on the secondary side not less than those specified in table 16, but using the next lower step for rated impulse voltage		N/A

IEC 60335-2-80			
Clause	Requirement - Test	Result - Remark	Verdict
	Circuits supplied with a voltage lower than rated voltage, clearances of functional insulation are based on the working voltage used as the rated voltage in table 15		N/A
29.2	Creepage distances not less than those appropriate for the working voltage, taking into account the material group and the pollution degree.....:	(see appended table)	P
	Pollution degree 2 applies, unless		N/A
	- precautions taken to protect the insulation; pollution degree 1		N/A
	- insulation subjected to conductive pollution; pollution degree 3		P
	Microenvironment is pollution degree 3 unless insulation is enclosed or located that it is unlikely to be exposed to pollution during normal use. (IEC 60335-2-80)		P
	A force of 2 N is applied to bare conductors, other than heating elements		P
	A force of 30 N is applied to accessible surfaces		P
	In a double insulation system, the working voltage for both the basic and supplementary insulation is taken as the working voltage across the complete double insulation system		P
29.2.1	Creepage distances of basic insulation not less than specified in table 17.....:	(see appended table)	P
	However, if the working voltage is periodic and has a frequency exceeding 30 kHz, the creepage distances are also determined from table 2 of IEC 60664-4, these values being used if exceeding the values in table 17 .....		N/A
	Except for pollution degree 1, corresponding creepage distance not less than the minimum specified for the clearance in table 16, if the clearance has been checked according to the test of clause 14 .....		N/A
29.2.2	Creepage distances of supplementary insulation at least those specified for basic insulation in table 17, or .....	(see appended table)	P
	Table 2 of IEC 60664-4, as applicable .....		N/A
29.2.3	Creepage distances of reinforced insulation at least double those specified for basic insulation in table 17, or .....	(see appended table)	P
	Table 2 of IEC 60664-4, as applicable .....		N/A

IEC 60335-2-80			
Clause	Requirement - Test	Result - Remark	Verdict
29.2.4	Creepage distances of functional insulation not less than specified in table 18.....:	(see appended table)	P
	However, if the working voltage is periodic and has a frequency exceeding 30 kHz, the creepage distances are also determined from table 2 of IEC 60664-4, these values being used if exceeding the values in table 18 .....		N/A
	Creepage distances may be reduced if the appliance complies with clause 19 with the functional insulation short-circuited		P
29.3	Supplementary and reinforced insulation have adequate thickness, or a sufficient number of layers, to withstand the electrical stresses		P
	Compliance checked:		--
	- by measurement, in accordance with 29.3.1, or		P
	- by an electric strength test in accordance with 29.3.2, or		N/A
	- by an assessment of the thermal quality of the material combined with an electric strength test, in accordance with 29.3.3, and		N/A
	for accessible parts of reinforced insulation consisting of a single layer, by measurement in accordance with 29.3.4, or		N/A
	- as specified in subclause 6.3 of IEC 60664-4 for insulation that is subjected to any periodic voltage having a frequency exceeding 30 kHz		N/A
29.3.1	Supplementary insulation have a thickness of at least 1 mm	Plastic enclosure : 1,2 mm; Control panel: 2,4 mm	P
	Reinforced insulation have a thickness of at least 2 mm		N/A
29.3.2	Each layer of material withstand the electric strength test of 16.3 for supplementary insulation		N/A
	Supplementary insulation consist of at least 2 layers		N/A
	Reinforced insulation consist of at least 3 layers		N/A
29.3.3	The insulation is subjected to the dry heat test Bb of IEC 60068-2-2, followed by		N/A
	the electric strength test of 16.3		N/A
	If the temperature rise during the tests of clause 19 does not exceed the value specified in table 3, the test of IEC 60068-2-2 is not carried out		N/A

IEC 60335-2-80			
Clause	Requirement - Test	Result - Remark	Verdict
29.3.4	Thickness of accessible parts of reinforced insulation consisting of a single layer not less than specified in table 19.....:		N/A
30	RESISTANCE TO HEAT AND FIRE		--
30.1	External parts of non-metallic material,		P
	parts supporting live parts, and		P
	parts of thermoplastic material providing supplementary or reinforced insulation		P
	sufficiently resistant to heat		P
	Ball-pressure test according to IEC 60695-10-2		P
	External parts tested at 40 °C plus the maximum temperature rise determined during the test of clause 11, or at 75 °C, whichever is the higher; temperature (°C).....:	(see appended table)	P
	Parts supporting live parts tested at 40°C plus the maximum temperature rise determined during the test of clause 11, or at 125 °C, whichever is the higher; temperature (°C) .....	Certified switch, timer and motor capacitor	P
	Parts of thermoplastic material providing supplementary or reinforced insulation tested at 25 °C plus the maximum temperature rise determined during clause 19, if higher; temperature (°C) .....		N/A
30.2	Parts of non-metallic material resistant to ignition and spread of fire		P
	This requirement does not apply to:		--
	parts having a mass not exceeding 0,5 g, provided the cumulative effect is unlikely to propagate flames that originate inside the appliance by propagating flames from one part to another, or		N/A
	decorative trims, knobs and other parts unlikely to be ignited or to propagate flames that originate inside the appliance		P
	Compliance checked by the tests of 30.2.1 and 30.2.3		P
	For base material of printed circuit boards, 30.2.4 applies		P
30.2.1	Parts of non-metallic material subjected to the glow-wire test of IEC 60695-2-11 at 550 °C	(see appended table)	P
	However, test not carried out if the material is classified as having a glow-wire flammability index according to IEC 60695-2-12 of at least 550 °C, or		N/A

IEC 60335-2-80			
Clause	Requirement - Test	Result - Remark	Verdict
	the material is classified at least HB40 according to IEC 60695-11-10		N/A
	Parts for which the glow-wire test cannot be carried out need to meet the requirements in ISO 9772 for material classified HBF		N/A
30.2.2	Not applicable. (IEC 60335-2-80)		P
30.2.3	Appliances operated while unattended, tested as specified in 30.2.3.1 and 30.2.3.2		P
	The tests are not applicable to conditions as specified .....		N/A
30.2.3.1	Parts of non-metallic material supporting connections carrying a current exceeding 0,2 A during normal operation, and		P
	parts of non-metallic material, other than small parts, within a distance of 3 mm,		P
	subjected to the glow-wire test of IEC 60695-2-11 with a test severity of 850 °C	(see appended table)	P
	Glow-wire applied to an interposed shielding material, if relevant		N/A
	The glow-wire test is not carried out on parts of material classified as having a glow-wire flammability index according to IEC 60695-2-12 of at least 850 °C		N/A
30.2.3.2	Parts of non-metallic material supporting connections, and		P
	parts of non-metallic material within a distance of 3mm,		P
	subjected to glow-wire test of IEC 60695-2-11		P
	The test severity is:		--
	- 750 °C, for connections carrying a current exceeding 0,2 A during normal operation	(see appended table)	P
	- 650 °C, for other connections	(see appended table)	P
	Glow-wire applied to an interposed shielding material, if relevant		N/A
	However, the glow-wire test of 750 °C or 650 °C as appropriate, is not carried out on parts of material fulfilling both or either of the following classifications:		--
	- a glow-wire ignition temperature according to IEC 60695-2-13 of at least:		N/A
	<ul style="list-style-type: none"> <li>775 °C, for connections carrying a current exceeding 0,2 A during normal operation</li> </ul>		N/A

IEC 60335-2-80			
Clause	Requirement - Test	Result - Remark	Verdict
	<ul style="list-style-type: none"> <li>675 °C, for other connections</li> </ul>		N/A
	- a glow-wire flammability index according to IEC 60695-2-12 of at least:		N/A
	- 750 °C, for connections carrying a current exceeding 0,2 A during normal operation		N/A
	- 650 °C, for other connections		N/A
	The glow-wire test is also not carried out on small parts. These parts are to:		--
	- comprise material having a glow-wire ignition temperature of at least 775 °C or 675 °C as appropriate, or		N/A
	- comprise material having a glow-wire flammability index of at least 750 °C or 650 °C as appropriate, or		N/A
	- comply with the needle-flame test of Annex E, or		N/A
	- comprise material classified as V-0 or V-1 according to IEC 60695-11-10		N/A
	The consequential needle-flame test of Annex E applied to non-metallic parts that encroach within the vertical cylinder placed above the centre of the connection zone and on top of the non-metallic parts supporting current-carrying connections, and parts of non-metallic material within a distance of 3 mm of such connections if these parts are those:		--
	- parts that withstood the glow-wire test of IEC 60695-2-11 of 750 °C or 650 °C as appropriate, but produce a flame that persist longer than 2 s, or		N/A
	- parts that comprised material having a glow-wire flammability index of at least 750 °C or 650 °C as appropriate, or		N/A
	- small parts, that comprised material having a glow-wire flammability index of at least 750 °C or 650 °C as appropriate, or		N/A
	- small parts for which the needle-flame test of Annex E was applied, or		N/A
	- small parts for which a material classification of V-0 or V-1 was applied		N/A
	However, the consequential needle-flame test is not carried out on non-metallic parts, including small parts, within the cylinder that are:		--
	- parts having a glow-wire ignition temperature of at least 775 °C or 675 °C as appropriate, or		N/A
	- parts comprising material classified as V-0 or V-1 according to IEC 60695-11-10, or		N/A



IEC 60335-2-80			
Clause	Requirement - Test	Result - Remark	Verdict
	- parts shielded by a flame barrier that meets the needle-flame test of Annex E or that comprises material classified as V-0 or V-1 according to IEC 60695-11-10		N/A
30.2.4	Base material of printed circuit boards subjected to the needle-flame test of Annex E		P
	Test not applicable to conditions as specified.....:		N/A
31	RESISTANCE TO RUSTING		--
	Relevant ferrous parts adequately protected against rusting		P
	Tests specified in part 2 when necessary		N/A
32	RADIATION, TOXICITY AND SIMILAR HAZARDS		--
	Appliance does not emit harmful radiation or present a toxic or similar hazard due to their operation in normal use		P
	Compliance is checked by the limits or tests specified in part 2, if relevant		N/A
A	ANNEX A (INFORMATIVE) ROUTINE TESTS		--
	Description of routine tests to be carried out by the manufacturer		N/A
B	ANNEX B (NORMATIVE) APPLIANCES POWERED BY RECHARGEABLE BATTERIES		--
	The following modifications to this standard are applicable for appliances powered by batteries that are recharged in the appliance		N/A
	This annex does not apply to battery chargers		N/A
3.1.9	Appliance operated under the following conditions:		N/A
	- the appliance, supplied by its fully charged battery, operated as specified in relevant part 2		N/A
	- the battery is charged, the battery being initially discharged to such an extent that the appliance cannot operate		N/A
	-if possible, the appliance is supplied from the supply mains through its battery charger, the battery being initially discharged to such an extent that the appliance cannot operate. The appliance is operated as specified in relevant part 2		N/A

<b>IEC 60335-2-80</b>			
Clause	Requirement - Test	Result - Remark	Verdict
	- if the appliance incorporates inductive coupling between two parts that are detachable from each other, the appliance is supplied from the supply mains with the detachable part removed		N/A
3.6.2	Part to be removed in order to discard the battery is not considered to be detachable		N/A
5.B.101	Appliances supplied from the supply mains tested as specified for motor-operated appliances		N/A
7.1	Battery compartment for batteries intended to be replaced by the user, marked with battery voltage and polarity of the terminals		N/A
	The positive terminal indicated by symbol IEC 60417-5005 and the negative terminal by symbol IEC 60417-5006		N/A
7.6	Symbols 60417-5005 and IEC 60417-5006		N/A
7.12	The instructions give information regarding charging		N/A
	The instructions for appliances incorporating batteries intended to be replaced by the user includes required information		N/A
	Details about how to remove batteries containing materials hazardous to the environment given		N/A
7.15	Markings placed on the part of the appliance connected to the supply mains		N/A
8.2	Appliances having batteries that according to the instruction may be replaced by the user need only have basic insulation between live parts and the inner surface of the battery compartment		N/A
	If the appliance can be operated without batteries, double or reinforced insulation required		N/A
11.7	The battery is charged for the period stated in the instructions or 24 h.....:		N/A
19.1	Appliances subjected to tests of 19.B.101, 19.B.102 and 19.B.103		N/A
19.10	Not applicable		N/A
19.B.101	Appliances supplied at rated voltage for 168 h, the battery being continually charged		N/A
19.B.102	For appliances having batteries that can be removed without the aid of a tool, short-circuit of the terminals of the battery, the battery being fully charged,		N/A

IEC 60335-2-80			
Clause	Requirement - Test	Result - Remark	Verdict
19.B.103	Appliances having batteries replaceable by the user supplied at rated voltage under normal operation with the battery removed or in any position allowed by the construction		N/A
21.B.101	Appliances having pins for insertion into socket-outlets have adequate mechanical strength		N/A
	Part of the appliance incorporating the pins subjected to the free fall test, procedure 2, of IEC 60068-2-31, the number of falls being:		N/A
	- 100, if the mass of the part does not exceed 250 g (g) .....		N/A
	- 50, if the mass of the part exceeds 250 g .....		N/A
	After the test, the requirements of 8.1, 15.1.1, 16.3 and clause 29 are met		N/A
22.3	Appliances having pins for insertion into socket-outlets tested as fully assembled as possible		N/A
25.13	An additional lining or bushing not required for interconnection cords in class III appliances or class III constructions operating at safety extra-low voltage not containing live parts		N/A
30.2	For parts of the appliance connected to the supply mains during the charging period, 30.2.3 applies		N/A
	For other parts, 30.2.2 applies		N/A
C	ANNEX C (NORMATIVE) AGEING TEST ON MOTORS		--
	Tests, as described, carried out when doubt with regard to the temperature classification of the insulation of a motor winding		N/A
	Test conditions as specified		N/A
D	ANNEX D (NORMATIVE) THERMAL MOTOR PROTECTORS		--
	Applicable to appliances having motors that incorporate thermal motor protectors necessary for compliance with the standard		N/A
	Test conditions as specified		N/A
E	ANNEX E (NORMATIVE) NEEDLE-FLAME TEST		--
	Needle-flame test carried out in accordance with IEC 60695-11-5, with the following modifications:		P
7	Severities		--
	The duration of application of the test flame is 30 s ± 1 s		P

IEC 60335-2-80			
Clause	Requirement - Test	Result - Remark	Verdict
9	Test procedure		--
9.1	The specimen so arranged that the flame can be applied to a vertical or horizontal edge as shown in the examples of Figure 1		P
9.2	The first paragraph does not apply		P
	If possible, the flame is applied at least 10 mm from a corner		P
9.3	The test is carried out on one specimen		P
	If the specimen does not withstand the test, the test may be repeated on two additional specimens, both withstanding the test		N/A
11	Evaluation of test results		--
	The duration of burning not exceeding 30 s		N/A
	However, for printed circuit boards, the duration of burning not exceeding 15 s		P
F	ANNEX F (NORMATIVE) CAPACITORS		--
	Capacitors likely to be permanently subjected to the supply voltage, and used for radio interference suppression or voltage dividing, comply with the following clauses of IEC 60384-14, with the following modifications:		N/A
1.5	Terms and definitions		N/A
1.5.3	Class X capacitors tested according to subclass X2		N/A
1.5.4	This subclause is applicable		N/A
1.6	Marking		N/A
	Items a) and b) are applicable		N/A
3.4	Approval testing		N/A
3.4.3.2	Table 3 is applicable as described		N/A
4.1	Visual examination and check of dimensions		N/A
	This subclause is applicable		N/A
4.2	Electrical tests		N/A
4.2.1	This subclause is applicable		N/A
4.2.5	This subclause is applicable		N/A
4.2.5.2	Only table 11 is applicable		N/A
	Values for test A apply		N/A
	However, for capacitors in heating appliances the values for test B or C apply		N/A
4.12	Damp heat, steady state		N/A

IEC 60335-2-80			
Clause	Requirement - Test	Result - Remark	Verdict
	This subclause is applicable		N/A
	Only insulation resistance and voltage proof are checked		N/A
4.13	Impulse voltage		N/A
	This subclause is applicable		N/A
4.14	Endurance		N/A
	Subclauses 4.14.1, 4.14.3, 4.14.4 and 4.14.7 are applicable		N/A
4.14.7	Only insulation resistance and voltage proof are checked		N/A
	No visible damage		N/A
4.17	Passive flammability test		N/A
	This subclause is applicable		N/A
4.18	Active flammability test		N/A
	This subclause is applicable		N/A
G	ANNEX G (NORMATIVE) SAFETY ISOLATING TRANSFORMERS		--
	The following modifications to this standard are applicable for safety isolating transformers:		N/A
7	Marking and instructions		N/A
7.1	Transformers for specific use marked with:		N/A
	-name, trademark or identification mark of the manufacturer or responsible vendor .....		N/A
	-model or type reference .....		N/A
17	Overload protection of transformers and associated circuits		N/A
	Fail-safe transformers comply with subclause 15.5 of IEC 61558-1		N/A
22	Construction		N/A
	Subclauses 19.1 and 19.1.2 of IEC 61558-2-6 are applicable		N/A
29	Clearances, creepage distances and solid insulation		N/A
29.1, 29.2, 29.3	The distances specified in items 2a, 2c and 3 in table 13 of IEC 61558-1 apply		N/A
	For insulated winding wires complying with subclause 19.12.3 of IEC 61558-1 there are no requirements for clearances or creepage distances		N/A

IEC 60335-2-80			
Clause	Requirement - Test	Result - Remark	Verdict
	For windings providing reinforced insulation, the distance specified in item 2c of table 13 of IEC 61558-1 is not assessed		N/A
	For safety isolating transformers subjected to periodic voltages with a frequency exceeding 30 kHz, the clearances, creepage distances and solid insulation values specified in IEC 60664-4 are applicable, if greater than the values specified in items 2a, 2c and 3 in table 13 of IEC 61558-1		N/A
H	ANNEX H (NORMATIVE) SWITCHES		--
	Switches comply with the following clauses of IEC 61058-1, as modified below:		N/A
	The tests of IEC 61058-1 carried out under the conditions occurring in the appliance		N/A
	Before being tested, switches are operated 20 times without load		N/A
8	Marking and documentation		N/A
	Switches are not required to be marked		N/A
	However, a switch that can be tested separately from the appliance marked with the manufacturer's name or trade mark and the type reference		N/A
13	Mechanism		N/A
	The tests may be carried out on a separate sample		N/A
15	Insulation resistance and dielectric strength		N/A
15.1	Not applicable		N/A
15.2	Not applicable		N/A
15.3	Applicable for full disconnection and micro-disconnection		N/A
17	Endurance		N/A
	Compliance is checked on three separate appliances or switches		N/A
	For 17.2.4.4, the number of cycles declared according to 7.1.4 is 10 000, unless		N/A
	otherwise specified in 24.1.3 of the relevant part 2 of IEC 60335 .....		N/A
	Switches for operation under no load and which can be operated only by a tool, and		N/A
	switches operated by hand that are interlocked so that they cannot be operated under load,		N/A
	are not subjected to the tests		N/A

IEC 60335-2-80			
Clause	Requirement - Test	Result - Remark	Verdict
	However, switches without this interlock are subjected to the test of 17.2.4.4 for 100 cycles of operation		N/A
	Subclauses 17.2.2 and 17.2.5.2 not applicable		N/A
	The ambient temperature during the test is that occurring in the appliance during the test of Clause 11 in IEC 60335-1		N/A
	The temperature rise of the terminals not more than 30 K above the temperature rise measured in clause 11 of IEC 60335-1 (K).....:		N/A
20	Clearances, creepage distances, solid insulation and coatings of rigid printed board assemblies		N/A
	This clause is applicable to clearances and creepage distances for functional insulation, across full disconnection and micro-disconnection, as stated in table 24		N/A
I	ANNEX I (NORMATIVE) MOTORS HAVING BASIC INSULATION THAT IS INADEQUATE FOR THE RATED VOLTAGE OF THE APPLIANCE		--
	The following modifications to this standard are applicable for motors having basic insulation that is inadequate for the rated voltage of the appliance:		N/A
8	Protection against access to live parts		N/A
8.1	Metal parts of the motor are considered to be bare live parts		N/A
11	Heating		N/A
11.3	The temperature rise of the body of the motor is determined instead of the temperature rise of the windings		N/A
11.8	The temperature rise of the body of the motor, where in contact with insulating material, not exceeding values in table 3 for the relevant insulating material		N/A
16	Leakage current and electric strength		N/A
16.3	Insulation between live parts of the motor and its other metal parts is not subjected to the test		N/A
19	Abnormal operation		N/A
19.1	The tests of 19.7 to 19.9 are not carried out		N/A
19.I.101	Appliance operated at rated voltage with each of the following fault conditions:		N/A
	- short circuit of the terminals of the motor, including any capacitor incorporated in the motor circuit		N/A

IEC 60335-2-80			
Clause	Requirement - Test	Result - Remark	Verdict
	- short circuit of each diode of the rectifier		N/A
	- open circuit of the supply to the motor		N/A
	- open circuit of any parallel resistor, the motor being in operation		N/A
	Only one fault simulated at a time, the tests carried out consecutively		N/A
22	Construction		N/A
22.1.101	For class I appliances incorporating a motor supplied by a rectifier circuit, the d.c. circuit being insulated from accessible parts of the appliance by double or reinforced insulation		N/A
	Compliance checked by the tests specified for double and reinforced insulation		N/A
J	ANNEX J (NORMATIVE) COATED PRINTED CIRCUIT BOARDS		--
	Testing of protective coatings of printed circuit boards carried out in accordance with IEC 60664-3 with the following modifications:		N/A
5.7	Conditioning of the test specimens		N/A
	When production samples are used, three samples of the printed circuit board are tested		N/A
5.7.1	Cold		N/A
	The test is carried out at -25 °C		N/A
5.7.3	Rapid change of temperature		N/A
	Severity 1 is specified		N/A
5.9	Additional tests		N/A
	This subclause is not applicable		N/A
K	ANNEX K (NORMATIVE) OVERVOLTAGE CATEGORIES		--
	The information on overvoltage categories is extracted from IEC 60664-1		P
	Overvoltage category is a numeral defining a transient overvoltage condition		P
	Equipment of overvoltage category IV is for use at the origin of the installation		N/A
	Equipment of overvoltage category III is equipment in fixed installations and for cases where the reliability and the availability of the equipment is subject to special requirements		N/A



IEC 60335-2-80			
Clause	Requirement - Test	Result - Remark	Verdict
	Equipment of overvoltage category II is energy consuming equipment to be supplied from the fixed installation		P
	If such equipment is subjected to special requirements with regard to reliability and availability, overvoltage category III applies		N/A
	Equipment of overvoltage category I is equipment for connection to circuits in which measures are taken to limit transient overvoltages to an appropriate low level		N/A
L	ANNEX L (INFORMATIVE) GUIDANCE FOR THE MEASUREMENT OF CLEARANCES AND CREEPAGE DISTANCES		--
	Information for the determination of clearances and creepage distances		P
M	ANNEX M (NORMATIVE) POLLUTION DEGREE		--
	The information on pollution degrees is extracted from IEC 60664-1		P
	Pollution		--
	The microenvironment determines the effect of pollution on the insulation, taking into account the macroenvironment		P
	Means may be provided to reduce pollution at the insulation by effective enclosures or similar		P
	Minimum clearances specified where pollution may be present in the microenvironment		P
	Degrees of pollution in the microenvironment		--
	For evaluating creepage distances, the following degrees of pollution in the microenvironment are established:		--
	- pollution degree 1: no pollution or only dry, non-conductive pollution occurs. The pollution has no influence		N/A
	- pollution degree 2: only non-conductive pollution occurs, except that occasionally a temporary conductivity caused by condensation is to be expected		N/A
	- pollution degree 3: conductive pollution occurs or dry non-conductive pollution occurs that becomes conductive due to condensation that is to be expected		P

IEC 60335-2-80			
Clause	Requirement - Test	Result - Remark	Verdict
	- pollution degree 4: the pollution generates persistent conductivity caused by conductive dust or by rain or snow		N/A
N	ANNEX N (NORMATIVE) PROOF TRACKING TEST		--
	The proof tracking test is carried out in accordance with IEC 60112 with the following modifications:		P
7	Test apparatus		--
7.3	Test solutions		--
	Test solution A is used		P
10	Determination of proof tracking index (PTI)		--
10.1	Procedure		--
	The proof voltage is 100V, 175V, 400V or 600V...:	175 V	P
	The test is carried out on five specimens		P
	In case of doubt, additional test with proof voltage reduced by 25V, the number of drops increased to 100		N/A
10.2	Report		--
	The report states if the PTI value was based on a test using 100 drops with a test voltage of (PTI-25) V		N/A
O	ANNEX O (INFORMATIVE) SELECTION AND SEQUENCE OF THE TESTS OF CLAUSE 30		--
	Description of tests for determination of resistance to heat and fire		P
P	ANNEX P (INFORMATIVE) GUIDANCE FOR THE APPLICATION OF THIS STANDARD TO APPLIANCES USED IN WARM DAMP EQUABLE CLIMATES		--
	Modifications applicable for class 0 and 01 appliances having a rated voltage exceeding 150V, intended to be used in countries having a warm damp equable climate and that are marked WDaE		N/A
	Modifications may also be applied to class 1 appliances having a rated voltage exceeding 150V, intended to be used in countries having a warm damp equable climate and that are marked WdaE, if liable to be connected to a supply mains that excludes the protective earthing conductor		N/A
5.7	The ambient temperature for the tests of clauses 11 and 13 is 40 +3/0 °C		N/A
7.1	The appliance marked with the letters WDaE		N/A

IEC 60335-2-80			
Clause	Requirement - Test	Result - Remark	Verdict
7.12	The instructions state that the appliance is to be supplied through a residual current device (RCD) having a rated residual operating current not exceeding 30 mA		N/A
	The instructions state that the appliance is considered to be suitable for use in countries having a warm damp equable climate, but may also be used in other countries		N/A
11.8	The values of Table 3 are reduced by 15 K		N/A
13.2	The leakage current for class I appliances not exceeding 0,5 mA		N/A
15.3	The value of t is 37 °C		N/A
16.2	The leakage current for class I appliances not exceeding 0,5 mA (mA):		N/A
19.13	The leakage current test of 16.2 is applied in addition to the electric strength test of 16.3		N/A
Q	ANNEX Q (INFORMATIVE) SEQUENCE OF TESTS FOR THE EVALUATION OF ELECTRONIC CIRCUITS		--
	Description of tests for appliances incorporating electronic circuits		P
R	ANNEX R (NORMATIVE) SOFTWARE EVALUATION		--
	Programmable electronic circuits requiring software incorporating measures to control the fault/error conditions specified in table R.1 or R.2 validated in accordance with the requirements of this annex		N/A
R.1	Programmable electronic circuits using software		N/A
	Programmable electronic circuits requiring software incorporating measures to control the fault/error conditions specified in table R.1 or R.2 constructed so that the software does not impair compliance with the requirements of this standard		N/A
R.2	Requirements for the architecture		N/A
	Programmable electronic circuits requiring software incorporating measures to control the fault/error conditions specified in table R.1 or R.2 use measures to control and avoid software-related faults/errors in safety-related data and safety-related segments of the software		N/A
R.2.1.1	Programmable electronic circuits requiring software incorporating measures to control the fault/error conditions specified in table R.2 have one of the following structures:		N/A
	- single channel with periodic self-test and monitoring		N/A

IEC 60335-2-80			
Clause	Requirement - Test	Result - Remark	Verdict
	- dual channel (homogenous) with comparison		N/A
	- dual channel (diverse) with comparison		N/A
	Programmable electronic circuits requiring software incorporating measures to control the fault/error conditions specified in table R.1 have one of the following structures:		N/A
	- single channel with functional test		N/A
	- single channel with periodic self-test		N/A
	- dual channel without comparison		N/A
R.2.2	Measures to control faults/errors		N/A
R.2.2.1	When redundant memory with comparison is provided on two areas of the same component, the data in one area is stored in a different format from that in the other area		N/A
R.2.2.2	Programmable electronic circuits with functions requiring software incorporating measures to control the fault/error conditions specified in table R.2 and that use dual channel structures with comparison, have additional fault/error detection means for any fault/errors not detected by the comparison		N/A
R.2.2.3	For programmable electronic circuits with functions requiring software incorporating measures to control the fault/error conditions specified in table R.1 or R.2, means are provided for the recognition and control of errors in transmissions to external safety-related data paths		N/A
R.2.2.4	For programmable electronic circuits with functions requiring software incorporating measures to control the fault/error conditions specified in table R.1 or R.2, the programmable electronic circuits incorporate measures to address the fault/errors in safety-related segments and data indicated in table R.1 and R.2 as appropriate		N/A
R.2.2.5	For programmable electronic circuits with functions requiring software incorporating measures to control the fault/error conditions specified in table R.1 or R.2, detection of a fault/error occur before compliance with clause 19 is impaired		N/A
R.2.2.6	The software is referenced to relevant parts of the operating sequence and the associated hardware functions		N/A
R.2.2.7	Labels used for memory locations are unique		N/A
R.2.2.8	The software is protected from user alteration of safety-related segments and data		N/A

IEC 60335-2-80			
Clause	Requirement - Test	Result - Remark	Verdict
R.2.2.9	Software and safety-related hardware under its control is initialized and terminates before compliance with clause 19 is impaired		N/A
R.3	Measures to avoid errors		N/A
R.3.1	General		N/A
	For programmable electronic circuits with functions requiring software incorporating measures to control the fault/error conditions specified in table R.1 or R.2, the following measures to avoid systematic fault in the software are applied		N/A
	Software that incorporates measures used to control the fault/error conditions specified in table R.2 is inherently acceptable for software required to control the fault/error conditions specified in table R.1		N/A
R.3.2	Specification		N/A
R.3.2.1	Software safety requirements:		N/A
	The specification of the software safety requirements includes the descriptions listed		N/A
R.3.2.2	Software architecture		N/A
R.3.2.2.1	The specification of the software architecture includes the aspects listed - techniques and measures to control software faults/errors (refer to R.2.2); - interactions between hardware and software; - partitioning into modules and their allocation to the specified safety functions; - hierarchy and call structure of the modules (control flow); - interrupt handling; - data flow and restrictions on data access; - architecture and storage of data; - time-based dependencies of sequences and data		N/A
R.3.2.2.2	The architecture specification is validated against the specification of the software safety requirements by static analysis		N/A
R.3.2.3	Module design and coding		N/A
R.3.2.3.1	Based on the architecture design, software is suitably refined into modules		N/A
	Software module design and coding is implemented in a way that is traceable to the software architecture and requirements		N/A
R.3.2.3.2	Software code is structured		N/A

IEC 60335-2-80			
Clause	Requirement - Test	Result - Remark	Verdict
R.3.2.3.3	Coded software is validated against the module specification by static analysis		N/A
	The module specification is validated against the architecture specification by static analysis		N/A
R.3.3.3	Software validation		N/A
	The software is validated with reference to the requirements of the software safety requirements specification		N/A
	Compliance is checked by simulation of:		N/A
	- input signals present during normal operation		N/A
	- anticipated occurrences		N/A
	- undesired conditions requiring system action		N/A

TABLE R.1 – GENERAL FAULT/ERROR CONDITIONS						
Component <sub>1)</sub>	Fault/error	Acceptable measures <sup>2)3)</sup>	Definitions	Document reference for applied measure	Document reference for applied test	Verdict
1 CPU 1.1 Registers	Stuck at	Functional test, or periodic self-test using either: - static memory test, or - word protection with single bit redundancy	H.2.16.5 H.2.16.6 H.2.19.6 H.2.19.8.2			N/A
1.2 VOID						N/A
1.3 Programme counter	Stuck at	Functional test, or Periodic self-test, or Independent time-slot monitoring, or Logical monitoring of the programme sequence	H.2.16.5 H.2.16.6 H.2.18.10.4 H.2.18.10.2			N/A
2 Interrupt handling and execution	No interrupt or too frequent interrupt	Functional test, or time-slot monitoring	H.2.16.5 H.2.18.10.4			N/A

IEC 60335-2-80						
Clause	Requirement - Test		Result - Remark			Verdict
3 Clock	Wrong frequency (for quartz synchronized clock: harmonics/sub-harmonics only)	Frequency monitoring, or time slot monitoring	H.2.18.10.1 H.2.18.10.4			N/A
4. Memory 4.1 Invariable memory	All single bit faults	Periodic modified checksum, or multiple checksum, or word protection with single bit redundancy	H.2.19.3.1 H.2.19.3.2 H.2.19.8.2			N/A
4.2 Variable memory	DC fault	Periodic static memory test, or word protection with single bit redundancy	H.2.19.6 H.2.19.8.2			N/A
4.3 Addressing (relevant to variable and invariable memory)	Stuck at	Word protection with single bit redundancy including the address	H.2.19.8.2			N/A
5 Internal data path	Stuck at DC fault	Word protection with single bit redundancy Comparison of redundant CPUs by either: - reciprocal comparison - independent hardware comparator	H.2.19.8.2  H.2.18.15 H.2.18.3			N/A
5.1 VOID						N/A
5.2 Addressing	Wrong address	Word protection with single bit redundancy including the address	H.2.19.8.2			N/A
6 External communication	Hamming distance 3	Word protection with multi-bit redundancy, or CRC – single work, or Transfer redundancy, or Protocol test	H.2.19.8.1  H.2.19.4.1 H.2.18.2.2 H.2.18.14			N/A
6.1 VOID						N/A
6.2 VOID						N/A

IEC 60335-2-80						
Clause	Requirement - Test		Result - Remark			Verdict
6.3 Timing	Wrong point in time  Wrong sequence	Time-slot monitoring, or scheduled transmission  Time-slot and logical monitoring, or  Comparison of redundant communication channels by either: - reciprocal comparison - independent hardware comparator  Logical monitoring, or time-slot monitoring, or Scheduled transmission (same options as for wrong point in time)	H.2.18.10. 4  H.2.18.18  H.2.18.10. 3  H.2.18.15 H.2.18.3  H.2.18.10. 2 H.2.18.10. 4 H.2.18.18			N/A
7 Input/output periphery	Fault conditions specified in 19.11.2	Plausibility check  Comparison of redundant communication channels by either: - reciprocal comparison - independent hardware comparator	H.2.18.13  H.2.18.15 H.2.18.3			N/A
7.1 VOID						N/A
7.2 Analog I/O 7.2.1 A/D and D/A- converter	Fault conditions specified in 19.11.2	Plausibility check	H.2.18.13			N/A
7.2.2 Analog multiplexer	Wrong addressing	Plausibility check	H.2.18.13			N/A
8 VOID						N/A
9 Custom chips <sup>4)</sup> e.g. ASIC, GAL, Gate array	Any output outside the static and dynamic functional specification	Periodic self-test	H.2.16.6			N/A



IEC 60335-2-80			
Clause	Requirement - Test	Result - Remark	Verdict

NOTE A Stuck-at fault model denotes a fault model representing an open circuit or a non-varying signal level. A DC fault model denotes a stuck-at fault model incorporating short circuit between signal lines.

1) For fault/error assessment, some components are divided into their sub-functions.  
 2) For each sub-function in the table, the Table R.2 measure will cover the software fault/error.  
 3) Where more than one measure is given for a sub-function, these are alternatives.  
 4) To be divided as necessary by the manufacturer into sub-functions.

IEC 60335-2-80			
Clause	Requirement - Test	Result - Remark	Verdict

10.1	TABLE: Power input deviation					P
Input deviation of/at:	P rated (W)	P measured (W)	dP (W, %)	Required dP (W, %)	Remark	
230 V, 50 Hz	40	28,1	-29,8	+20 %	For TX-1208A	
230 V, 60 Hz	40	29,7	-25,8	+20 %		
230 V, 50 Hz	60	57,3	-4,50	+20 %	For TX-1808A	
230 V, 60 Hz	60	68,0	+13,3	+20 %		
230 V, 50 Hz	45	42,9	-4,67	+20 %	For TX-1610R	
230 V, 60 Hz	45	49,7	+10,4	+20 %		
230 V, 50 Hz	45	44,6	-0,89	+20 %	For TX-1611R	
230 V, 60 Hz	45	48,5	+7,80	+20 %		

10.2	TABLE: Current deviation					N/A
Current deviation of/at:	I rated (A)	I measured (A)	dI (A, %)	Required dI (A, %)	Remark	

11.8-a	TABLE: Heating test, thermocouple measurements (For TX-1208A)			P
	Test voltage (V) .....		254,4 V	—
	Ambient, t1 (°C) .....		39,9 °C	—
	Ambient, t2 (°C) .....		39,8 °C	—
Thermocouple locations		Max. temperature rise measured, dT (K)	Max. temperature rise limit, dT (K)	
Supply cord		1,0	50-15=35	
Motor winding		64,6	115-15=100 / Class 155	
Motor running capacitor		5,9	T70-40=30	
External surface of motor cover		2,7	60-15=45	
Motor cover (inside)		5,1	For clause 30.1	
Control panel (inside)		0,6	For clause 30.1	
Timer knob (inside)		0,3	For clause 30.1	
Switch button		0,3	60-15=45	
Timer knob		0,7	60-15=45	
Internal wire		22,8	T80-40=40	
Ambient of switch		0,2	T55-40=15	

IEC 60335-2-80			
Clause	Requirement - Test	Result - Remark	Verdict

Ambient of timer	0,5	T55-40=15
Silicon rubber tube	25,9	145-15=130
Floor of test corner	0,4	65-15=50
Wall of test corner	0,2	65-15=50

<b>11.8-a</b>	<b>TABLE: Heating test, resistance method</b>					<b>P</b>
	Test voltage (V) .....	254,4 V			—	
	Ambient, t <sub>1</sub> (°C) .....	39,9 °C			—	
	Ambient, t <sub>2</sub> (°C) .....	39,8 °C			—	
Temperature rise of winding	R1 (Ω)	R2 (Ω)	dT (K)	Max. dT (K)	Insulation class	
Fan motor winding	2523,6	3254,3	79,6	115-15=100	155	

<b>11.8-b</b>	<b>TABLE: Heating test, thermocouple measurements (For TX-1808A)</b>					<b>P</b>
	Test voltage (V) .....	254,4 V			—	
	Ambient, t <sub>1</sub> (°C) .....	39,0 °C			—	
	Ambient, t <sub>2</sub> (°C) .....	39,7 °C			—	
Thermocouple locations	Max. temperature rise measured, dT (K)		Max. temperature rise limit, dT (K)			
Supply cord	0,5		50-15=45			
Motor winding	61,3		115-15=100 / Class 155			
Motor running capacitor	6,1		T70-40=30			
External surface of motor cover	3,1		60-15=45			
Motor cover (inside)	3,1		For clause 30.1			
Control panel (inside)	0,3		For clause 30.1			
Timer knob (inside)	0,3		For clause 30.1			
Switch button	0,7		60-15=45			
Timer knob	0,6		60-15=45			
Internal wire	32,4		T80-40=40			
Ambient of switch	1,1		T55-40=15			
Ambient of timer	0,8		T55-40=15			
Silicon rubber tube	31,9		145-15=130			
Floor of test corner	0,4		65-15=50			
Wall of test corner	0,1		65-15=50			
<b>11.8-b</b>	<b>TABLE: Heating test, resistance method</b>					<b>P</b>

IEC 60335-2-80						
Clause	Requirement - Test			Result - Remark	Verdict	
	Test voltage (V) .....			254,4 V	—	
	Ambient, t <sub>1</sub> (°C) .....			39,0 °C	—	
	Ambient, t <sub>2</sub> (°C) .....			39,7 °C	—	
Temperature rise of winding		R1 (Ω)	R2 (Ω)	dT (K)	Max. dT (K)	Insulation class
Fan motor winding		1013,9	1322,3	82,5	115-15=100	155

11.8-c	TABLE: Heating test, thermocouple measurements (For TX-1611R with synchronous motor TDY50)			P	
	Test voltage (V) .....			254,4 V	—
	Ambient, t <sub>1</sub> (°C) .....			38,8 °C	—
	Ambient, t <sub>2</sub> (°C) .....			39,7 °C	—
Thermocouple locations		Max. temperature rise measured, dT (K)		Max. temperature rise limit, dT (K)	
Supply cord		1,6		50-15=35	
Synchronous motor winding		13,4		80-15=65 / Class 120	
Motor winding		44,3		115-15=100 / Class 155	
Motor running capacitor		8,0		T70-40=30	
Press button surface (metal paint)		1,0		35-15=20	
External surface of motor cover		0,4		60-15=45	
Internal wire		2,5		T80-40=40	
PCB		5,0		120-15=105	
X2 capacitor		5,0		T85-40=45	
Varistor		3,6		T85-40=45	
Motor cover (inside)		4,6		For clause 30.1	
Control panel (inside)		1,8		For clause 30.1	
Press button (inside)		2,1		For clause 30.1	
Floor of test corner		0,3		65-15=50	
Wall of test corner		0,5		65-15=50	
11.8-c	TABLE: Heating test, resistance method			P	
	Test voltage (V) .....			254,4 V	—
	Ambient, t <sub>1</sub> (°C) .....			38,8 °C	—
	Ambient, t <sub>2</sub> (°C) .....			39,7 °C	—

IEC 60335-2-80					
Clause	Requirement - Test			Result - Remark	Verdict
Temperature rise of winding	R1 (Ω)	R2 (Ω)	dT (K)	Max. dT (K)	Insulation class
Motor winding	1753,2	2253,9	77,2	115-15=100	155
Synchronous motor winding	9559,0	11095,0	43,0	90-15=75	120

11.8-d	TABLE: Heating test, thermocouple measurements (For TX-1610R with synchronous motor WYJ50-8A1)				P
	Test voltage (V) .....	:	254,4 V		—
	Ambient, t <sub>1</sub> (°C) .....	:	39,0 °C		—
	Ambient, t <sub>2</sub> (°C) .....	:	39,7 °C		—
Thermocouple locations			Max. temperature rise measured, dT (K)	Max. temperature rise limit, dT (K)	
Supply cord			1,8	50-15=35	
Synchronous motor winding			19,3	80-15=65 / Class 120	
Motor winding			60,2	115-15=100 / Class 150	
Motor running capacitor			17,6	T70-40=30	
Press button surface(metal paint)			0,9	35-15=20	
External surface of motor winding			3,5	60-15=45	
Internal wire			25,3	T80-40=40	
PCB			5,9	120-40=80	
X2 capacitor			5,5	T85-40=45	
Varistor			2,7	T85-40=45	
Motor cover (inside)			6,1	For clause 30.1	
Control panel (inside)			2,5	For clause 30.1	
Press button (inside)			2,3	For clause 30.1	
Floor of test corner			1,2	65-15=50	
Wall of test corner			0,8	65-15=50	
11.8-d	TABLE: Heating test, resistance method				P
	Test voltage (V) .....	:	254,4 V		—
	Ambient, t <sub>1</sub> (°C) .....	:	39,0 °C		—
	Ambient, t <sub>2</sub> (°C) .....	:	39,7 °C		—
Temperature rise of winding	R1 (Ω)	R2 (Ω)	dT (K)	Max. dT (K)	Insulation class
Motor winding	1631,2	2068,7	72,7	115-15=100	155

IEC 60335-2-80					
Clause	Requirement - Test			Result - Remark	Verdict

Synchronous motor winding	10694	13065	59,9	90-15=75	120
---------------------------	-------	-------	------	----------	-----

13.2	TABLE: Leakage current			P
	Heating appliances: 1.15 x rated input (W).....:		--	—
	Motor-operated and combined appliances: 1.06 x rated voltage (V).....:		254,4 V	—
Leakage current between		I (mA)	Max. allowed I (mA)	
Live part and control panel		0,01	0,35 Peak	
Live part and plastic enclosure of motor		0,01	0,35 Peak	
Supplementary information: The highest value of leakage current was marked.				

13.3	TABLE: Electric strength		P
Test voltage applied between:		Voltage (V)	Breakdown (Yes/No)
Live part and control panel		3000	No
Live part and plastic enclosure of motor		3000	No

14	TABLE: Transient overvoltages					N/A
Clearance between:		CI (mm)	Required CI (mm)	Rated impulse voltage (V)	Impulse test voltage (V)	Flashover (Yes/No)

16.2	TABLE: Leakage current			P
	Single phase appliances: 1.06 x rated voltage (V).....:		254,4V	—
	Three phase appliances 1.06 x rated voltage divided by $\sqrt{3}$ (V).....:		--	—
Leakage current between		I (mA)	Max. allowed I (mA)	
Live part and control panel		0,02	0,25	
Live part and plastic enclosure of motor		0,03	0,25	
Supplementary information: The highest value of leakage current was marked.				

IEC 60335-2-80			
Clause	Requirement - Test	Result - Remark	Verdict

16.3	TABLE: Electric strength		P
Test voltage applied between:		Voltage (V)	Breakdown (Yes/No)
Live part and control panel		3000	No
Live part and plastic enclosure of motor		3000	No

17	TABLE: Overload protection, thermocouple measurements		N/A
Temperature rise of part/at:		dT (K)	Max. dT (K)

17	TABLE: Overload protection, resistance method				N/A
Temperature of winding	R1 (Ω)	R2 (Ω)	dT (K)	T (°C)	Max. T (°C)

19	Abnormal operation conditions						N/A
Operational characteristics		YES/NO	Operational conditions				
Are there electronic circuits to control the appliance operation?							
Are there "off" or "stand-by" position?							
The unintended operation of the appliance results in dangerous malfunction?							
Sub-clause	Operating conditions description	Test results description	PEC description	EMP 19.11.4	Software type required	19.11.3 PEC	Final result
19.2							
19.3							
19.4							
19.5							
19.6							
19.7							
19.8							
19.10							
19.11.2							
19.11.4.8							

IEC 60335-2-80			
Clause	Requirement - Test	Result - Remark	Verdict

19.10X							
--------	--	--	--	--	--	--	--

<b>19.13</b>	<b>TABLE: Abnormal operation, temperature rises</b>	<b>P</b>
--------------	---	----------

Thermocouple locations	Max. temperature rise measured, dT (K)					Max. temperature rise limit, dT (K)
	(a)	(b)	(c)	(d)	(e)	
Motor winding	101,9	97,7	111,4	—	—	240-25=215 / Class 155
Synchronous motor winding	—	—	—	25,3	20,8	165-25=140 / Class 120
Motor cover (inside)	39,9	32	34,8	24,4	2,3	For clause 30.1
Control panel (inside)	0,8	1,9	2,9	2,6	2,5	For clause 30.1
Press button (inside)	—	—	4,7	1,9	2,8	For clause 30.1
Plastic enclosure	—	2,0	—	—	—	For clause 30.1
Timer knob (inside)	0,9	—	—	—	—	For clause 30.1

Supplementary information:  
 (a) TX-1208A was tested with fan motor M-1208 locked and motor running capacitor open-circuit;  
 (b) TX-1808A was tested with fan motor M-1808 locked and motor running capacitor open-circuit;  
 (c) TX-1611R was tested with fan motor M-1608 locked and motor running capacitor open-circuit;  
 (d) TX-1611R was tested with Synchronous motor TDY-50 locked;  
 (e) TX-1610R was tested with Synchronous motor WYJ50-8A1 locked.



IEC 60335-2-80			
Clause	Requirement - Test	Result - Remark	Verdict

24.1	TABLE: Components					P
Component	Manufacturer/ trademark	Type/model	Value / rating	Standard	Approval/ Reference	
Plug	Shenzhen YeTatsu Electrical Co., Ltd	YTV11	AC 250 V, 2,5 A	DIN VDE 0620-1 IEC 60884-1	VDE 40040232	
Alt.	Zhongshan Guzhen Hong Li Cable & Appliance Factory	HL-6	AC 250 V, 2,5 A	DIN VDE 0620-1 IEC 60884-1	VDE 40009738	
Alt.	Jiangmen Gomentech Electrical Co., Ltd.	GM-02	AC 250 V, 2,5 A	DIN VDE 0620-1 IEC 60884-1	VDE 40022512	
BS Plug	Luen Tai (Ip's) Electrical Manufactory	9518	AC 250 V, 3,0 A	BS1363-1	KM 40790	
Alt.	Zhongshan Guzhen Hong Li Cable & Appliance Factory.	HL-17	AC 250 V, 3,0 A	BS1363-1	ASTA 882	
Power cord*	Shenzhen YeTatsu Electrical. Co., Ltd	H03VVH2-F H05VVH2-F	2 x 0,5mm <sup>2</sup> 2 x 0,75mm <sup>2</sup>	IEC 60227-5	VDE 40039926	
Alt.	Jiangmen Gomentech Electrical Co., Ltd.	H03VVH2-F H05VVH2-F	2 x 0,5mm <sup>2</sup> 2 x 0,75mm <sup>2</sup>	IEC 60227-5	VDE 40018946	
Alt.	Zhongshan Guzhen Hong Li Cable & Appliance Factory.	H03VVH2-F H05VVH2-F	2 x 0,5mm <sup>2</sup> 2 x 0,75mm <sup>2</sup>	IEC 60227-5	VDE 139259	
Fan motor (for TX-1208, TX-1208A, TX-1208B)	Jiangmen Techxin Electric Appliance Manufacture Co., Ltd.	M-1208	AC 220-240 V, 40 W, Class 155 (Class F)	IEC/EN 60335-1 IEC/EN 60335-2-80	Tested with appliance	
Fan motor (for TX-1608, TX-1608A, TX-1608B, TX-1608V, TX-1609, TX-1611, TX-1608BR, TX-1608VR, TX-1610R, TX-1611R)	Jiangmen Techxin Electric Appliance Manufacture Co., Ltd.	M-1608	AC 220-240 V, 45 W, Class 155 (Class F)	IEC/EN 60335-1 IEC/EN 60335-2-80	Tested with appliance	
Fan motor (for TX-1808A, TX-1811)	Jiangmen Techxin Electric Appliance Manufacture Co., Ltd.	M-1808	AC 220-240 V, 60 W, Class 155 (Class F)	IEC/EN 60335-1 IEC/EN 60335-2-80	Tested with appliance	
Thermal link built in fan motor	Hubei Honghu Blue Light Electronic Co., Ltd.	RH130-2	AC 250 V, 2 A, Tf130°C	IEC/EN 60691	TUV R 50077755	

IEC 60335-2-80					
Clause	Requirement - Test		Result - Remark		Verdict
Thermal link built in fan motor (Alternative)	Aupo Electronics Ltd	A4-F	AC 250 V, 2 A, Tf130°C	IEC/EN 60691	VDE 40008720
Motor capacitor (for TX-1208, TX-1208A, TX-1208B)	Guangdong Fengming Electronic Tech. Co., Ltd.	CBB61-P2	0,8µF or 1,0µF or 1,2µF, AC 450V, T85	IEC/EN 60252-1	TUV R 50163114
Alt.	Foshan Shunde Hongye Electrical Appliance Co., Ltd.	CBB61	0,8µF or 1,0µF or 1,2µF, AC 450V, T85	IEC/EN 60252-1	TUV R 50281536
Alt.	Jiangmen Global Electronic Co., Ltd.	CBB61F	0,8µF or 1,0µF or 1,2µF, AC 450V, T85	IEC/EN 60252-1	TUV R 50277584
Alt.	Foshan City Shunde District Ronggui Sunbird Electrical Equipment Co., Ltd.	CBB61-2	0,8µF or 1,0µF or 1,2µF, AC 450V, T85	IEC/EN 60252-1	TUV R 50283769
Motor capacitor (for TX-1608, TX-1608A, TX-1608B, TX-1608V, TX-1609, TX-1611, TX-1608BR, TX-1608VR, TX-1610R, TX-1611R)	Guangdong Fengming Electronic Tech. Co., Ltd.	CBB61-P2	1,0µF or 1,2µF or 1,5µF, AC 450V, T85	IEC/EN 60252-1	TUV R 50163114
Alt.	Foshan Shunde Hongye Electrical Appliance Co., Ltd.	CBB61	1,0µF or 1,2µF or 1,5µF, AC 450V, P2, T85	IEC/EN 60252-1	TUV R 50281536
Alt.	Jiangmen Global Electronic Co., Ltd.	CBB61F	1,0µF or 1,2µF or 1,5µF, AC 450V, P2, T85	IEC/EN 60252-1	TUV R 50277584
Alt.	Foshan City Shunde District Ronggui Sunbird Electrical Equipment Co., Ltd.	CBB61-2	1,0µF or 1,2µF or 1,5µF, AC 450V, P2, T85	IEC/EN 60252-1	TUV R 50283769
Motor capacitor (for TX-1808A, TX-1811)	Guangdong Fengming Electronic Tech. Co., Ltd.	CBB61-P2	1,5µF or 1,8µF or 2,0µF, AC 450V, T85	IEC/EN 60252-1	TUV R 50163114
Alt.	Foshan Shunde Hongye Electrical Appliance Co., Ltd.	CBB61	1,5µF or 1,8µF or 2,0µF, AC 450V, T85	IEC/EN 60252-1	TUV R 50281536

IEC 60335-2-80					
Clause	Requirement - Test			Result - Remark	Verdict
Alt.	Jiangmen Global Electronic Co., Ltd.	CBB61F	1,5µF or 1,8µF or 2,0µF, AC 450V, T85	IEC/EN 60252-1	TUV R 50277584
Alt.	Foshan City Shunde District Ronggui Sunbird Electrical Equipment Co., Ltd.	CBB61-2	1,5µF or 1,8µF or 2,0µF, AC 450V, T85	IEC/EN 60252-1	TUV R 50283769
Synchronous motor (For TX-1610R, TX-1611R)	Foshan Sanshui Haixun Micromotor Co., Ltd.	TDY-50	AC 220-240 V, 50/60Hz, 4W, CW/CCW	IEC/EN 60335-1 IEC/EN 60335-2-80	VDE 40018733
Alt.	Zhongshan Xiaolan Huafeng Electrical Appliance Manufactory	WYJ50-8A1	AC 220-240 V 50/60Hz, 4W, CW/CCW	IEC/EN 60335-1 IEC/EN 60335-2-80	TUV R 50278865
Switch (For TX-1208, TX-1608)	Zhongshan Xiaolan Huafeng Electrical Appliance Manufactory	ZD-516	AC 250 V, 1(1) A, 1E4, T55	IEC/EN 61058-1	TUV R 50082610
Switch (for TX-1208A, TX-1208B, TX-1608A, TX-1608B, TX-1608V, TX-1609, TX-1611, TX-1808A, TX-1811)	Zhongshan Xiaolan Huafeng Electrical Appliance Manufactory	ZD-418	AC 250 V, 1(1) A, 1E4, T55	IEC/EN 61058-1	TUV R 50082610
Switch (Alternative for TX-1208A, TX-1208B, TX-1608A, TX-1608B, TX-1608V, TX-1609, TX-1611, TX-1808A, TX-1811)	Zhongshan Xiaolan Cheng Lian Hardware Electrical Factory	CK-04	AC 250 V, 1 A, 1E4, T55	IEC/EN 61058-1	TUV R 50087410
Timer (For TX-1208A, TX-1608A, TX1808A, TX-1811)	Foshan shunde Huaxinde Industry Co., Ltd.	DFJ-60, DFJ-120	AC 250 V, 1,6 A, 3E3, T55	IEC/EN 60730-1 IEC/EN 60730-2-9	TUV B 1204559050 02

IEC 60335-2-80					
Clause	Requirement - Test			Result - Remark	Verdict
Timer (Alternative for TX-1208A, TX-1608A, TX-1808A, TX-1811)	Ninghai Naite Precise Injection Electrical Co., Ltd.	DFJ-60, DFJ-120	AC 250 V, 1,6 A, 1E4, T55	IEC/EN 60730-2- 7 IEC/EN 60730-1	TUV R 50222455
PCB (For TX-1608BR, TX-1608VR, TX-1610R, TX-1611R)	KINGBOARD LAMINATES HOLDINGS LTD	KB-3151C	V-0, 130°C	IEC/EN 60335-1 IEC/EN 60335-2- 80	Tested with appliance UL E123995
PCB Alternative (For TX-1608BR, TX-1608VR, TX-1610R, TX-1611R)	SHANDONG JINBAO ELECTRONICS CO LTD	ZD-90F	V-0, 130°C	IEC/EN 60335-1 IEC/EN 60335-2- 80	Tested with appliance UL E141940
Fuse link (For TX-1608BR, TX-1608VR, TX-1610R, TX-1611R)	Dongguan Better Electronic Technology Co., Ltd.	332	AC 250 V, 1 A, T	IEC/EN 60127-1; IEC/EN 60127-3	TUV J 50158950
Fuse link (Alternative For TX-1608BR, TX-1608VR, TX-1610R, TX-1611R)	Shenzhen Deer Electronics Co., Ltd.	32T	AC 250 V, 1 A, T	IEC/EN 60127-1; IEC/EN 60127-3	VDE 40024074
X2 Capacitor (For TX-1608BR, TX-1608VR, TX-1610R, TX-1611R)	Guangdong Fengming Electronic Tech. Co., Ltd.	MKP-X2	AC 275 V, 0,68μF, T105 or T85	IEC/EN 60384-14	VDE 40025702
X2 Capacitor Alternative (For TX-1608BR, TX-1608VR, TX-1610R, TX-1611R)	Shunde Da Hua Electric Co., Ltd.	HD-MKP	AC 275 V, 0,68μF, T105 or T85	IEC/EN 60384-14	VDE 40027182
X2 Capacitor (For TX-1608BR, TX-1608VR, TX-1610R, TX-1611R)	Guangdong Fengming Electronic Tech. Co., Ltd.	MKP-X2	AC 275 V, 1,2μF and 0,1μF, T105 or T85	IEC/EN 60384-14	VDE 40025702

IEC 60335-2-80					
Clause	Requirement - Test			Result - Remark	Verdict
X2 Capacitor (Alternative for TX-1608BR, TX-1608VR, TX-1610R, TX-1611R)	Shunde Da Hua Electric Co., Ltd.	HD-MKP	AC 275 V, 1,2μF and 0,1μF, T105 or T85	IEC/EN 60384-14	VDE 40027182
Varistor (For TX-1608BR, TX-1608VR, TX-1610R, TX-1611R)	Xi'An Xiwuer Electronics & Information Co., Ltd.	MYG3- 10KAC300	Class 25 A, Peak 2500 A, continuous AC 50-680 V, T85	IEC/EN 61051-1 IEC/EN 61051-2 IEC/EN 61051-2- 2	VDE 40008528
Wire connector	Heavy power Co., Ltd.	CE2	300V, 105 °C	IEC/EN 60335-1 IEC/EN 60335-2- 80	Tested with appliance UL E113650
Alt.	ASCEND ELECTRICAL LTD	CE2	300V, 105 °C	IEC/EN 60335-1 IEC/EN 60335-2- 80	Tested with appliance UL E310863
Internal wire to fan motor	SHUNDE BEIJIAO JINHUI PLASTIC METALS FACTORY	1015	18-22 AWG, 600 V, 105 °C	IEC/EN 60335-1 IEC/EN 60335-2- 80	Tested with appliance UL E237283
Internal wire to fan motor (Alternative)	GUANG DONG XIN LONG ENTERPRISE CO	1015	18-22 AWG, 600 V, 105 °C	IEC/EN 60335-1 IEC/EN 60335-2- 80	Tested with appliance UL E207567
Internal wire to fan motor (Alternative)	ZHONG SHAN YONG ROI ELECTRIC FACTORY CO LTD	1015	18-22 AWG, 600 V, 105 °C	IEC/EN 60335-1 IEC/EN 60335-2- 80	Tested with appliance UL E204893
Internal wire to fan motor (Alternative)	FOSHAN CITY SHUNDE HONG JIAN ZHI XIAN INDUSTRY CO LTD	1015	18-22 AWG, 600 V, 105 °C	IEC/EN 60335-1 IEC/EN 60335-2- 80	Tested with appliance UL E188132
Internal wire to fan motor (Alternative)	ZHONGSHAN NANTOU BOYU WIRE MFR	1015	18-22 AWG, 600 V, 105 °C	IEC/EN 60335-1 IEC/EN 60335-2- 80	Tested with appliance UL E314089
Internal wire to fan motor (Alternative)	GUANGZHOU ZHIHE ELECTRONIC CO LTD	1015	18-22 AWG, 600 V, 105 °C	IEC/EN 60335-1 IEC/EN 60335-2- 80	Tested with appliance UL E251728
Internal wire to fan motor (Alternative)	ZHONGSHAN MEITAO ELECTRIC INDUSTRIAL CO LTD	1015	18-22 AWG, 600 V, 105 °C	IEC/EN 60335-1 IEC/EN 60335-2- 80	Tested with appliance UL E351651

IEC 60335-2-80					
Clause	Requirement - Test		Result - Remark		Verdict
Internal wire to fan motor (Alternative)	FOSHAN CITY SHUNDE DISTRICT BEIJIAO QINGLANG ELECTRICAL FACTORY	1015	18-22 AWG, 600 V, 105 °C	IEC/EN 60335-1 IEC/EN 60335-2-80	Tested with appliance UL E365204
Internal wire to synchronous motor (Alternative)	SHUNDE BEIJIAO JINHUI PLASTIC METALS FACTORY	1015	18-22 AWG, 600 V, 105 °C	IEC/EN 60335-1 IEC/EN 60335-2-80	Tested with appliance UL E237283
Internal wire to synchronous motor (Alternative)	ZHONGSHAN MEITAO ELECTRIC INDUSTRIAL CO LTD	1015	18-22 AWG, 600 V, 105 °C	IEC/EN 60335-1 IEC/EN 60335-2-80	Tested with appliance UL E351651
Internal wire to synchronous motor (Alternative)	FOSHAN CITY SHUNDE DISTRICT BEIJIAO QINGLANG ELECTRICAL FACTORY	1015	18-22 AWG, 600 V, 105 °C	IEC/EN 60335-1 IEC/EN 60335-2-80	Tested with appliance UL E365204
Internal wire to synchronous motor (Alternative)	SHUNDE BEIJIAO JINHUI PLASTIC METALS FACTORY	1007	24-26 AWG, 300 V, 80 °C	IEC/EN 60335-1 IEC/EN 60335-2-80	Tested with appliance UL E237283
Internal wire to synchronous motor (Alternative)	GUANG DONG XIN LONG ENTERPRISE CO	1007	24-26 AWG, 300 V, 80 °C	IEC/EN 60335-1 IEC/EN 60335-2-80	Tested with appliance UL E207567
Internal wire to synchronous motor (Alternative)	ZHONG SHAN YONG ROI ELECTRIC FACTORY CO LTD	1007	24-26 AWG, 300 V, 80 °C	IEC/EN 60335-1 IEC/EN 60335-2-80	Tested with appliance UL E204893
Internal wire to synchronous motor (Alternative)	FOSHAN CITY SHUNDE HONG JIAN ZHI XIAN INDUSTRY CO LTD	1007	24-26 AWG, 300 V, 80 °C	IEC/EN 60335-1 IEC/EN 60335-2-80	Tested with appliance UL E188132
Internal wire to synchronous motor (Alternative)	ZHONGSHAN NANTOU BOYU WIRE MFR	1007	24-26 AWG, 300 V, 80 °C	IEC/EN 60335-1 IEC/EN 60335-2-80	Tested with appliance UL E314089
Internal wire to synchronous motor (Alternative)	GUANGZHOU ZHIHE ELECTRONIC CO LTD	1007	24-26 AWG, 300 V, 80 °C	IEC/EN 60335-1 IEC/EN 60335-2-80	Tested with appliance UL E251728

IEC 60335-2-80					
Clause	Requirement - Test			Result - Remark	Verdict
Internal wire to synchronous motor (Alternative)	ZHONGSHAN MEITAO ELECTRIC INDUSTRIAL CO LTD	1007	24-26 AWG, 600 V, 80 °C	IEC/EN 60335-1 IEC/EN 60335-2-80	Tested with appliance UL E351651
Internal wire to synchronous motor (Alternative)	FOSHAN CITY SHUNDE DISTRICT BEIJIAO QINGLANG ELECTRICAL FACTORY	1007	24-26 AWG, 600 V, 80 °C	IEC/EN 60335-1 IEC/EN 60335-2-80	Tested with appliance UL E365204
Plastic enclosure	EXXONMOBIL CHEMICAL ASIA PACIFIC	AP03B	PP, HB	IEC/EN 60335-1 IEC/EN 60335-2-80	Tested with appliance UL E225564
Supplementary information: * The power cords H03VVH2-F are applicable for models which do not exceed 3kg after installing with alternative fan guard or pedestal.					

IEC 60335-2-80			
Clause	Requirement - Test	Result - Remark	Verdict

28.1	TABLE: Threaded part torque test			N/A
Threaded part identification	Diameter of thread (mm)	Column number (I, II, or III)	Applied torque (Nm)	

29.1	TABLE: Clearances			P
	Overvoltage category.....: .....	II		—

Rated impulse voltage (V):	Min. cl (mm)	Type of insulation:				Verdict / Remark
		Basic (mm)	Functional (mm)	Supplementary (mm)	Reinforced (mm)	
330	0,2* / 0,5 / 0,8**	—	—	—	—	N/A
500	0,2* / 0,5 / 0,8**	—	—	—	—	N/A
800	0,2* / 0,5 / 0,8**	—	—	—	—	N/A
1 500	0,5 / 0,8** / 1,0***	—	—	—	—	N/A
2 500	<b>1,5 / (2,1) ****</b>	(a) 3,2 mm (b) 2,5 mm (c) 3,2 mm	—	—	—	P
2 500	<b>1,5 / 2,0***</b>	—	(d) 3,9 mm	—	—	P
2 500	<b>1,5 / 2,0***</b>	—	—	(e) 3,6 mm	—	P
4 000	<b>3,0 / 3,5***</b>	—	—	—	(f) 7,8 mm	P
6 000	5,5 / 6,0***	—	—	—	—	N/A
8 000	8,0 / 8,5***	—	—	—	—	N/A
10 000	11,0 / 11,5***	—	—	—	—	N/A

Supplementary information:

\*) For tracks on printed circuit boards if pollution degree 1 and 2  
 \*\*) For pollution degree 3  
 \*\*\*) If the construction is affected by wear, distortion, movement of the parts or during assembly  
 \*\*\*\*) For appliances having higher working voltages than rated voltage, the voltage used for determining clearances from table 16 shall be the sum of the rated impulse voltage and the difference between the peak value of the working voltage and the peak value of the rated voltage.

(a): Between fan motor M-1608 winding and stator;  
 (b) Between fan motor M-1208 winding and stator;  
 (c) Between fan motor M-1808 winding and stator;  
 (d): Between L and N of PCB;  
 (e): Between internal wire and accessible part;  
 (f): Between live part and accessible part



IEC 60335-2-80			
Clause	Requirement - Test	Result - Remark	Verdict

29.2	TABLE: Creepage distances, basic, supplementary and reinforced insulation										P
Working voltage (V)	Creepage distance (mm)							Type of insulation			Verdict
	Pollution degree										
	1	2			3						
		Material group			Material group						
		I	II	IIIa/IIIb	I	II	IIIa/IIIb*)	B**)	S**)	R**)	Verdict
≤50	0,18	0,6	0,85	1,2	1,5	1,7	1,9		—	—	N/A
≤50	0,18	0,6	0,85	1,2	1,5	1,7	1,9	—		—	N/A
≤50	0,36	1,2	1,7	2,4	3,0	3,4	3,8	—	—		N/A
125	0,28	0,75	1,05	1,5	1,9	2,1	2,4		—	—	N/A
125	0,28	0,75	1,05	1,5	1,9	2,1	2,4	—		—	N/A
125	0,56	1,5	2,1	3,0	3,8	4,2	4,8	—	—		N/A
250	0,56	1,25	1,8	2,5	3,2	3,6	4,0		—	—	N/A
250	0,56	1,25	1,8	2,5	3,2	3,6	<b>4,0</b>	—	(e) 5,2	—	P
250	1,12	2,5	3,6	5,0	6,4	7,2	<b>8,0</b>	—	—	(f) 7,8	P
400	1,0	2,0	2,8	4,0	5,0	5,6	6,3 <b>2,1***</b>	(a) 3,2 (b) 2,5 (c) 3,2	—	—	P
400	1,0	2,0	2,8	4,0	5,0	5,6	6,3	—		—	N/A
400	2,0	4,0	5,6	8,0	10,0	11,2	12,6	—	—		N/A
500	1,3	2,5	3,6	5,0	6,3	7,1	8,0		—	—	N/A
500	1,3	2,5	3,6	5,0	6,3	7,1	8,0	—		—	N/A
500	2,6	5,0	7,2	10,0	12,6	14,2	16,0	—	—		N/A
>630 and ≤800	1,8	3,2	4,5	6,3	8,0	9,0	10,0		—	—	N/A
>630 and ≤800	1,8	3,2	4,5	6,3	8,0	9,0	10,0	—		—	N/A
>630 and ≤800	3,6	6,4	9,0	12,6	16,0	18,0	20,0	—	—		N/A
>800 and ≤1000	2,4	4,0	5,6	8,0	10,0	11,0	12,5		—	—	N/A
>800 and ≤1000	2,4	4,0	5,6	8,0	10,0	11,0	12,5	—		—	N/A
>800 and ≤1000	4,8	8,0	11,2	16,0	20,0	22,0	25,0	—	—		N/A
>1000 and ≤1250	3,2	5,0	7,1	10,0	12,5	14,0	16,0		—	—	N/A

IEC 60335-2-80											
Clause	Requirement - Test							Result - Remark			Verdict
>1000 and ≤1250	3,2	5,0	7,1	10,0	12,5	14,0	16,0	—		—	N/A
>1000 and ≤1250	6,4	10,0	14,2	20,0	25,0	28,0	32,0	—	—		N/A
>1250 and ≤1600	4,2	6,3	9,0	12,5	16,0	18,0	20,0		—	—	N/A
>1250 and ≤1600	4,2	6,3	9,0	12,5	16,0	18,0	20,0	—		—	N/A
>1250 and ≤1600	8,4	12,6	18,0	25,0	32,0	36,0	40,0	—	—		N/A
>1600 and ≤2000	5,6	8,0	11,0	16,0	20,0	22,0	25,0		—	—	N/A
>1600 and ≤2000	5,6	8,0	11,0	16,0	20,0	22,0	25,0	—		—	N/A
>1600 and ≤2000	11,2	16,0	22,0	32,0	40,0	44,0	50,0	—	—		N/A
>2000 and ≤2500	7,5	10,0	14,0	20,0	25,0	28,0	32,0		—	—	N/A
>2000 and ≤2500	7,5	10,0	14,0	20,0	25,0	28,0	32,0	—		—	N/A
>2000 and ≤2500	15,0	20,0	28,0	40,0	50,0	56,0	64,0	—	—		N/A
>2500 and ≤3200	10,0	12,5	18,0	25,0	32,0	36,0	40,0		—	—	N/A
>2500 and ≤3200	10,0	12,5	18,0	25,0	32,0	36,0	40,0	—		—	N/A
>2500 and ≤3200	20,0	25,0	36,0	50,0	64,0	72,0	80,0	—	—		N/A
>3200 and ≤4000	12,5	16,0	22,0	32,0	40,0	45,0	50,0		—	—	N/A
>3200 and ≤4000	12,5	16,0	22,0	32,0	40,0	45,0	50,0	—		—	N/A
>3200 and ≤4000	25,0	32,0	44,0	64,0	80,0	90,0	100,0	—	—		N/A
>4000 and ≤5000	16,0	20,0	28,0	40,0	50,0	56,0	63,0		—	—	N/A
>4000 and ≤5000	16,0	20,0	28,0	40,0	50,0	56,0	63,0	—		—	N/A
>4000 and ≤5000	32,0	40,0	56,0	80,0	100,0	112,0	126,0	—	—		N/A
>5000 and ≤6300	20,0	25,0	36,0	50,0	63,0	71,0	80,0		—	—	N/A
>5000 and ≤6300	20,0	25,0	36,0	50,0	63,0	71,0	80,0	—		—	N/A
>5000 and ≤6300	40,0	50,0	72,0	100,0	126,0	142,0	160,0	—	—		N/A
>6300 and ≤8000	25,0	32,0	45,0	63,0	80,0	90,0	100,0		—	—	N/A
>6300 and ≤8000	25,0	32,0	45,0	63,0	80,0	90,0	100,0	—		—	N/A
>6300 and ≤8000	50,0	64,0	90,0	126,0	160,0	180,0	200,0	—	—		N/A
>8000 and ≤10000	32,0	40,0	56,0	80,0	100,0	110,0	125,0		—	—	N/A
>8000 and ≤10000	32,0	40,0	56,0	80,0	100,0	110,0	125,0	—		—	N/A
>8000 and ≤10000	64,0	80,0	112,0	160,0	200,0	220,0	250,0	—	—		N/A
>10000 and ≤12500	40,0	50,0	71,0	100,0	125,0	140,0	160,0		—	—	N/A
>10000 and ≤12500	40,0	50,0	71,0	100,0	125,0	140,0	160,0	—		—	N/A
>10000 and ≤12500	80,0	100,0	142,0	200,0	250,0	280,0	320,0	—	—		N/A

IEC 60335-2-80			
Clause	Requirement - Test	Result - Remark	Verdict

Supplementary information:

\*) Material group IIIb is allowed if the working voltage does not exceed 50 V

\*\*) B = Basic insulation, S = Supplementary insulation, R = Reinforced insulation

\*\*\*), Lacquered conductors of windings are considered to be bare conductors, but creepage distances need not be greater than the associated clearance specified in table 16 taking into account 29.1.1.

(a) Between fan motor M-1608 winding and stator;

(b) Between fan motor M-1208 winding and stator;

(c) Between fan motor M-1808 winding and stator;

(e) Between internal wire and accessible part;

(f) Between live part and accessible part

IEC 60335-2-80			
Clause	Requirement - Test	Result - Remark	Verdict

29.2	TABLE: Creepage distances, functional insulation							P
Working voltage (V)	Creepage distance (mm) Pollution degree							Verdict / Remark
	1	2			3			
	Material group			Material group				
	I	II	IIIa/IIIb	I	II	IIIa/IIIb <sup>*)</sup>		
≤10	0,08	0,4	0,4	0,4	1,0	1,0	1,0	N/A
50	0,16	0,56	0,8	1,0	1,4	1,6	1,8	N/A
125	0,25	0,71	1,0	1,4	1,8	2,0	2,2	N/A
250	0,42	1,0	1,4	2,0	2,5	2,8	<b>3,2</b>	P / (d) 3,9 mm
400	0,75	1,6	2,2	3,2	4,0	4,5	5,0	N/A
500	1,0	2,0	2,8	4,0	5,0	5,6	6,3	N/A
>630 and ≤800	1,8	3,2	4,5	6,3	8,0	9,0	10,0	N/A
>800 and ≤1000	2,4	4,0	5,6	8,0	10,0	11,0	12,5	N/A
>1000 and ≤1250	3,2	5,0	7,1	10,0	12,5	14,0	16,0	N/A
>1250 and ≤1600	4,2	6,3	9,0	12,5	16,0	18,0	20,0	N/A
>1600 and ≤2000	5,6	8,0	11,0	16,0	20,0	22,0	25,0	N/A
>2000 and ≤2500	7,5	10,0	14,0	20,0	25,0	28,0	32,0	N/A
>2500 and ≤3200	10,0	12,5	18,0	25,0	32,0	36,0	40,0	N/A
>3200 and ≤4000	12,5	16,0	22,0	32,0	40,0	45,0	50,0	N/A
>4000 and ≤5000	16,0	20,0	28,0	40,0	50,0	56,0	63,0	N/A
>5000 and ≤6300	20,0	25,0	36,0	50,0	63,0	71,0	80,0	N/A
>6300 and ≤8000	25,0	32,0	45,0	63,0	80,0	90,0	100,0	N/A
>8000 and ≤10000	32,0	40,0	56,0	80,0	100,0	110,0	125,0	N/A
>10000 and ≤12500	40,0	50,0	71,0	100,0	125,0	140,0	160,0	N/A

Supplementary information:  
<sup>\*)</sup> Material group IIIb is allowed if the working voltage does not exceed 50 V  
(d): Between L and N of PCB

IEC 60335-2-80																			
Clause	Requirement - Test											Result - Remark						Verdict	
<b>30</b>	<b>TABLE: Resistance to heat and fire</b>																	<b>P</b>	
Object/ part No.	Manufacturer / trademark	Type/ model	Ball pressure test °C				Glow wire test (GWT) °C				Glow-wire flammability index (GWFI) °C				Glow- wire ignition temp. (GWIT) °C		Needle - flame test (NFT)	Verdict	
			75	125	cl. 11 +40	cl. 19 +25	550	650		750		850	550	650	750	850			675
									te	ti	te	ti							
Plastic enclosure (Motor cover, Control panel)	EXXONMOBIL	AP03B	1,3 m m				X												P
Synchronous motor bobbin	Foshan Sanshui Haixun Micromotor Co., Ltd.	TDY-50						N	N										P
Synchronous motor bobbin	Zhongshan Xiaolan Huafeng Electrical Appliance Manufactory	WYJ50-8A1						N	N										P
Motor bobbin	Jiangmen Techxin	M-1208					X												P

IEC 60335-2-80																				
Clause	Requirement - Test										Result - Remark							Verdict		
	Electric Appliance Manufacture Co., Ltd.																			
Motor bobbin	Jiangmen Techxin Electric Appliance Manufacture Co., Ltd.	M-1608						X												P
Motor bobbin	Jiangmen Techxin Electric Appliance Manufacture Co., Ltd.	M-1808						X												P
Motor running capacitors	Guangdong Fengming Electronic Tech. Co., Ltd.	CBB61-P2									N	N	X							P
Motor running capacitors	Foshan Shunde Hongye Electrical Appliance Co., Ltd.	CBB61									N	N	X							P
Motor running capacitors	Jiangmen Global Electronic Co., Ltd.	CBB61F									N	N	X							P

IEC 60335-2-80																			
Clause	Requirement - Test										Result - Remark							Verdict	
Motor running capacitors	Foshan City Shunde District Ronggui Sunbird Electrical Equipment Co., Ltd.	CBB61-2									N	N	X						P
Wire connectors	---	---									N	N	X						P
X2 capacitors	---	---									N	N	X						P
Switches	---	---									N	N	X						P
Timers	---	---									N	N	X						P
PCBs	---	---																P	P
<p>Supplementary information:</p> <p>1) Parts of material classified at least HB40 or if relevant HBF</p> <p>2) Parts of material classified as V-0 or V-1</p> <p>3) Flame persisting longer than 2 s (= te – ti) need only be reported for unattended appliances</p> <p>4) Surrounding parts subjected to the needle-flame test of annex E</p> <p>5) Base material classified as V-0 or if relevant VTM-0</p> <p>6) The GWIT pre-selection option, the 850 °C GWF1 pre-selection option, and the 850 °C GWT are not applicable for attended appliances</p> <p>N denotes no flame occurred during the test.</p>																			

--- End of Report ---

**Attachment 1**

IEC 60335-1:2010/A1:2013			
Clause	Requirement - Test	Result - Remark	Verdict

<p align="center"><b>ATTACHMENT TO TEST REPORT IEC 60335-1 Household and similar electrical appliances – Safety – Part 1: General requirements</b></p>	
<b>Differences according to:</b>	IEC 60335-1:2010 +A1: 2013
<b>Attachment Form No.:</b>	IEC60335-1/A1_A
<b>Attachment Originator:</b>	SGS-CSTC
<b>Master Attachment:</b>	Date 2014-03

7	Marking and instructions		—
7.1	Add the following new paragraph after Note 4: Class II appliances and class III appliances incorporating a functional earth shall be marked with the symbol IEC 60417-5018 (2011-07).		N/A
7.3	In Note 3, replace the text of the example by the following. EXAMPLE: 230 V /400 V 3N : The appliance is only suitable for the voltage values indicated, 230 V being for single-phase, a.c. operation and 400 V 3N for three-phase, a.c. with neutral operation (an appliance with terminals for both supplies).		N/A
7.4	Replace the requirement by the following: If the appliance can be adjusted for different rated voltages or rated frequencies, the voltage or the frequency to which the appliance is adjusted shall be clearly discernible. If frequent changes in voltage setting or frequency setting are not required, this requirement is considered to be met if the rated voltage or rated frequency to which the appliance is to be adjusted can be determined from a wiring diagram fixed to the appliance.		N/A
7.6	Replace [symbol ISO 7000-0434 (2004-01)] by [symbol ISO 7000-0434A (2004-01)]		N/A
7.8	Add the following to the first paragraph of the requirement: – functional earthing terminals shall be indicated by symbol IEC 60417-5018 (2011-07).		N/A
7.12	Delete “for use” in the first paragraph and in the Note. Add the following after the existing last paragraph of the requirement: For appliances intended for use at altitudes exceeding 2 000 m, the maximum altitude of use shall be stated.		N/A
	The instructions for appliances incorporating a functional earth shall state the substance of the following: This appliance incorporates an earth connection for functional purposes only.		N/A



**Attachment 1**

IEC 60335-1:2010/A1:2013																																					
Clause	Requirement - Test	Result - Remark	Verdict																																		
7.12.1	Add the following text: For appliances marked with different rated voltages or different rated frequencies (separated by a /), instructions shall be included to indicate to the user or installer what action must be taken to adjust the appliance for operation at the required rated voltage or rated frequency.		N/A																																		
7.15	Add the following: The symbol IEC 60417-5018 (2011-07) shall be placed next to the symbol IEC 60417-5172 (2003-02) or the symbol IEC 60417-5180 (2003-02) as appropriate.		N/A																																		
8	Protection against access to live parts		—																																		
8.1.1	Delete the Note.		P																																		
10	Power input and current		—																																		
10.1	Replace the penultimate paragraph of the test specification by the following: If the power input varies throughout the operating cycle and the maximum value of the power input exceeds, by a factor greater than two, the arithmetic mean value of the power input occurring during a representative period, then the power input is the maximum value that is exceeded for more than 10 % of the representative period. Otherwise the power input is taken as the arithmetic mean value.		N/A																																		
10.2	Replace the penultimate paragraph of the test specification by the following: If the current varies throughout the operating cycle and the maximum value of the current exceeds, by a factor greater than two, the arithmetic mean value of the current occurring during a representative period, then the current is the maximum value that is exceeded for more than 10 % of the representative period. Otherwise the current is taken as the arithmetic mean value.		N/A																																		
11	Heating		—																																		
11.8	Delete the second sentence of the first paragraph		P																																		
	<p><b>Table 3 and its notes modification</b></p> <table border="1"> <tbody> <tr> <td colspan="2"><i>External enclosure of motor-operated appliances except handles held in normal use.<sup>26</sup></i></td> </tr> <tr> <td>- of bare metal</td> <td>48</td> </tr> <tr> <td>- of coated metal<sup>27</sup></td> <td>59</td> </tr> <tr> <td>- of glass and ceramic</td> <td>65</td> </tr> <tr> <td>- of plastic having a thickness exceeding 0,4 mm<sup>28</sup></td> <td>74</td> </tr> <tr> <td colspan="2"><i>Surfaces of handles, knobs, grips and similar parts which are continuously held in normal use (e.g. soldering irons).<sup>29</sup></i></td> </tr> <tr> <td>- of bare metal</td> <td>30</td> </tr> <tr> <td>- of coated metal<sup>27</sup></td> <td>34</td> </tr> <tr> <td>- of porcelain or vitreous material</td> <td>40</td> </tr> <tr> <td>- of rubber or of plastic having a thickness exceeding 0,4 mm<sup>28</sup></td> <td>50</td> </tr> <tr> <td>- of wood</td> <td>50</td> </tr> <tr> <td colspan="2"><i>Surfaces of handles, knobs, grips and similar parts<sup>3</sup> which are held for short periods only in normal use (e.g. switches).<sup>30</sup></i></td> </tr> <tr> <td>- of bare metal</td> <td>35</td> </tr> <tr> <td>- of coated metal<sup>27</sup></td> <td>39</td> </tr> <tr> <td>- of porcelain or vitreous material</td> <td>45</td> </tr> <tr> <td>- of rubber or of plastic having a thickness exceeding 0,4 mm<sup>28</sup></td> <td>60</td> </tr> <tr> <td>- of wood</td> <td>65</td> </tr> </tbody> </table>	<i>External enclosure of motor-operated appliances except handles held in normal use.<sup>26</sup></i>		- of bare metal	48	- of coated metal <sup>27</sup>	59	- of glass and ceramic	65	- of plastic having a thickness exceeding 0,4 mm <sup>28</sup>	74	<i>Surfaces of handles, knobs, grips and similar parts which are continuously held in normal use (e.g. soldering irons).<sup>29</sup></i>		- of bare metal	30	- of coated metal <sup>27</sup>	34	- of porcelain or vitreous material	40	- of rubber or of plastic having a thickness exceeding 0,4 mm <sup>28</sup>	50	- of wood	50	<i>Surfaces of handles, knobs, grips and similar parts<sup>3</sup> which are held for short periods only in normal use (e.g. switches).<sup>30</sup></i>		- of bare metal	35	- of coated metal <sup>27</sup>	39	- of porcelain or vitreous material	45	- of rubber or of plastic having a thickness exceeding 0,4 mm <sup>28</sup>	60	- of wood	65		P
<i>External enclosure of motor-operated appliances except handles held in normal use.<sup>26</sup></i>																																					
- of bare metal	48																																				
- of coated metal <sup>27</sup>	59																																				
- of glass and ceramic	65																																				
- of plastic having a thickness exceeding 0,4 mm <sup>28</sup>	74																																				
<i>Surfaces of handles, knobs, grips and similar parts which are continuously held in normal use (e.g. soldering irons).<sup>29</sup></i>																																					
- of bare metal	30																																				
- of coated metal <sup>27</sup>	34																																				
- of porcelain or vitreous material	40																																				
- of rubber or of plastic having a thickness exceeding 0,4 mm <sup>28</sup>	50																																				
- of wood	50																																				
<i>Surfaces of handles, knobs, grips and similar parts<sup>3</sup> which are held for short periods only in normal use (e.g. switches).<sup>30</sup></i>																																					
- of bare metal	35																																				
- of coated metal <sup>27</sup>	39																																				
- of porcelain or vitreous material	45																																				
- of rubber or of plastic having a thickness exceeding 0,4 mm <sup>28</sup>	60																																				
- of wood	65																																				

**Attachment 1**

IEC 60335-1:2010/A1:2013			
Clause	Requirement - Test	Result - Remark	Verdict
13	Leakage current and electric strength at operating temperature		—
13.2	In the first paragraph, after “class II appliances” add “, class II constructions” and replace the second sentence by the following: For class 0I appliances and class I appliances, C may be replaced by a low impedance ammeter responding to the rated frequency of the appliance.		P
	Replace the second paragraph by the following: The leakage current is measured between any pole of the supply and – accessible metal parts intended to be connected to protective earth, for class I appliances and class 0I appliances; – metal foil having an area not exceeding 20 cm × 10 cm which is in contact with accessible surfaces of insulating material and metal parts not intended to be connected to protective earth, for class 0 appliances, class II appliances, class II constructions and class III appliances.		P
	Replace the fourth paragraph by the following: For single-phase appliances, the measuring circuit is shown in the following figures: – if they are class II appliances or parts of class II construction, Figure 1; – if they are neither class II appliances nor parts of class II construction, Figure 2.		P
	Replace the sixth paragraph by the following: For three-phase with neutral (3N~) connected appliances, the measuring circuit is shown in the following figures: – if they are class II appliances or parts of class II construction, Figure 3; – if they are neither class II appliances nor parts of class II construction, Figure 4.		N/A
	Delete “For three-phase appliances,” from the first sentence of the seventh paragraph.		N/A
	Replace the third sentence of the seventh paragraph by the following: For three-phase without neutral (3~) connected appliances, the measuring circuit in Figure 3 or Figure 4 shall be used as applicable, but the neutral is not connected to the appliance.		N/A
	In the existing eighth paragraph, replace the first dashed item by the following: – for class II appliances and for parts of class II construction 0,35 mA peak		P
15	Moisture resistance		—
15.2	Replace the first paragraph of the test specification by the following: Compliance is checked by the following test using a spillage solution comprising water containing approximately 1 % NaCl and 0,6 % rinsing agent.		N/A

**Attachment 1**

IEC 60335-1:2010/A1:2013													
Clause	Requirement - Test	Result - Remark	Verdict										
	<p>Replace the fifth paragraph of the test specification by the following:                      The liquid container of the appliance is completely filled with the solution and a further quantity equal to 15 % of the capacity of the container or 0,25 l, whichever is the greater, is poured in steadily over a period of 1 min.</p>		N/A										
	<p>Add the following new text as a penultimate paragraph:                      Any commercially available rinsing agent may be used, but if there is any doubt with regards to the test results, the rinsing agent shall have the following properties:                      – viscosity, 17 mPa.s;                      – pH, 2,2 (1 % in water).                      and its composition shall be</p> <table border="1" data-bbox="400 902 1000 1021"> <thead> <tr> <th>Substance</th> <th>Parts by mass %</th> </tr> </thead> <tbody> <tr> <td>Plurafac ® LF 2212</td> <td>15,0</td> </tr> <tr> <td>Cumene sulfonate (40 % solution)</td> <td>11,5</td> </tr> <tr> <td>Citric acid (anhydrous)</td> <td>3,0</td> </tr> <tr> <td>Deionized water</td> <td>70,5</td> </tr> </tbody> </table>	Substance	Parts by mass %	Plurafac ® LF 2212	15,0	Cumene sulfonate (40 % solution)	11,5	Citric acid (anhydrous)	3,0	Deionized water	70,5		N/A
Substance	Parts by mass %												
Plurafac ® LF 2212	15,0												
Cumene sulfonate (40 % solution)	11,5												
Citric acid (anhydrous)	3,0												
Deionized water	70,5												
16	Leakage current and electric strength		—										
16.2	<p>Replace the first paragraph by the following:                      An a.c. test voltage is applied between live parts and                      – accessible metal parts intended to be connected to protective earth, for class I appliances and class 0I appliances;                      – metal foil having an area not exceeding 20 cm × 10 cm which is in contact with accessible surfaces of insulating material and metal parts not intended to be connected to protective earth, for class 0 appliances, class II appliances, class II constructions and class III appliances.</p>		P										
	<p>In the fourth paragraph, replace the first dashed item by the following:                      – for class II appliances and for parts of class II construction</p>		P										
19	ABNORMAL OPERATION		—										
19.7	<p>Add the following to the fourth paragraph.                      If the timer or programmer is an electronic type that operates to ensure compliance with the test before the maximum period under the conditions of Clause 11 is reached, it is considered to be a protective electronic circuit as well as a control that operates under the conditions of Clause 11.</p>		N/A										

**Attachment 1**

IEC 60335-1:2010/A1:2013			
Clause	Requirement - Test	Result - Remark	Verdict
19.11.4.4	Replace the first paragraph by the following: The power supply terminals of the appliance are subjected to voltage surges in accordance with IEC 61000-4-5, five positive impulses and five negative impulses being applied at the selected points. An open circuit test voltage of 2 kV is applicable for the line-to-line coupling mode, a generator having a source impedance of 2 Ω being used. An open circuit test voltage of 4 kV is applicable for the line-to-earth coupling mode, a generator having a source impedance of 12 Ω being used.		N/A
22	Construction		—
22.5	In the requirement, replace “exceeding” by “equal to or greater than”.		P
	Add the following text after the existing last paragraph of the test specification. If compliance relies on the operation of an electronic circuit, the electromagnetic phenomena tests of 19.11.4.3 and 19.11.4.4 are applied one at a time to the appliance. The discharge test is then repeated three times and for each test, the voltage shall not exceed 34 V.		N/A
22.32	Replace the words ‘Insulating material’ at the beginning of the 4th paragraph of the requirement by ‘Ceramic and similar porous material’ and combine this paragraph with the third paragraph of the requirement.		N/A
22.33	Add the following to the first sentence of the first paragraph of the requirement: “or unearthed metal parts that are separated from live parts by basic insulation only.”		N/A
22.35	In the second paragraph of the requirement add ‘and cordless appliances’ after ‘stationary appliances’.		N/A
	Add the following note after the requirement: NOTE A cordless appliance is an appliance that is connected to the supply only when placed on its associated stand.		N/A
22.53	Class II appliances and class III appliances that incorporate functionally earthed parts shall have at least double insulation or reinforced insulation between live parts and the functionally earthed parts.		N/A
22.54	Button cells and batteries designated R1 shall not be accessible without the aid of a tool unless the cover of their compartment can only be opened after at least two independent movements have been applied simultaneously.		N/A
23	Internal wiring		—

**Attachment 1**

IEC 60335-1:2010/A1:2013			
Clause	Requirement - Test	Result - Remark	Verdict
23.5	Replace Note 2 by the following text. For class II construction, the requirements for supplementary insulation and reinforced insulation apply except that the sheath of a cord complying with IEC 60227 or IEC 60245 may provide supplementary insulation.		N/A
	A single layer of internal wiring insulation does not provide reinforced insulation.		P
24	COMPONENTS		—
24.1	Replace Notes 1, 2, 3 and 4 by the following, and renumber Note 5 to Note 2.		—
	Compliance with the IEC standard for the relevant component does not necessarily ensure compliance with the requirements of this standard.		P
	Motors are not required to comply with IEC 60034-1. They are tested as part of the appliance according to this standard.		P
	Relays shall be tested as part of the appliance according to this standard. They may be alternatively tested to IEC 60730-1, in which case they must also meet the additional requirements in IEC 60335-1.		N/A
	Unless otherwise specified, the requirements of Clause 29 of this standard apply between live parts of components and accessible parts of the appliance. Unless otherwise specified, components may comply with the requirements for clearances and creepage distances for functional insulation as specified in the relevant component standard.		P
	Unless otherwise specified, the requirements of 30.2 of this standard apply to parts of nonmetallic material in components including parts of non-metallic material supporting currentcarrying connections inside components.		P
	Components that have not been previously tested and shown to comply with the IEC standard for the relevant component are tested according to the requirements of 30.2 of this standard.		P
	Components that have been previously tested and shown to comply with the resistance to fire requirements in the IEC standard for the relevant component need not be retested provided that – the severity specified in the component standard is not less than the severity specified in 30.2 of this standard, and – unless the pre-selection alternatives in 30.2 are used, the test report for the component states the values of $t_e$ and $t_i$ as required by IEC 60695-2-11.		N/A
	If the above two conditions are not satisfied, the component shall be tested as part of the appliance.		P
	NOTE 1 There are two levels of severity specified for appliances for which 30.2.3 is applicable.		P

**Attachment 1**

IEC 60335-1:2010/A1:2013			
Clause	Requirement - Test	Result - Remark	Verdict
	Power electronic converter circuits are not required to comply with IEC 62477-1. They are tested as part of the appliance according to this standard.		N/A
24.1.2	Add the following text as a new first paragraph. The relevant standard for transformers in associated switch mode power supplies is Annex BB of IEC 61558-2-16. Clause 26 of IEC 61558-1 and Annex H of IEC 61558-1 are not applicable.		N/A
24.1.4	Add the following new paragraph: Thermal cut-outs of the capillary type shall comply with the requirements for type 2.K controls in IEC 60730-2-9.		N/A
24.1.5	In the second sentence of the first paragraph, add "class II" before "appliances".		N/A
25	SUPPLY CONNECTION AND EXTERNAL FLEXIBLE CORDS		—
25.1	Replace the first dashed item of the requirement by the following: – supply cord fitted with a plug, the current rating and voltage rating of the plug being not less than the corresponding ratings of its associated appliance;		P
25.7	Delete the third dashed item in the first paragraph of the requirement.		P
25.10	Add the following as a new paragraph to the requirement. In multi-phase appliances, the colour of the neutral conductor of the supply cord, if any, shall be blue.		N/A
25.13	In the requirement, replace the second sentence by the following: If it is not evident from the construction of the appliance that the supply cord can be introduced without risk of damage, a non-detachable lining or non-detachable bushing shall be provided that complies with 29.3 for supplementary insulation.		N/A
25.15	Replace the second paragraph of the test specification by the following: A mark is made on the cord at a distance of approximately 20 mm from the cord anchorage or other suitable point. The mark is made while the cord is subjected to a pull force of – 100 N, for fixed appliances regardless of the mass of the appliance; – the value as shown in Table 12, for other appliances.		P
25.20	Delete "insulated" and "additionally" from the requirement.		P
27	Provision for earthing		—
27.1	In the first paragraph of the requirement replace "an insulation fault" by "a failure of basic insulation".		N/A
	Delete Note 1 and replace "Note 2" by "Note".		N/A

**Attachment 1**

IEC 60335-1:2010/A1:2013			
Clause	Requirement - Test	Result - Remark	Verdict
	Replace the third paragraph by the following: Class 0 appliances, class II appliances and class III appliances shall have no provision for protective earthing. Class II appliances and class III appliances may incorporate an earth for functional purposes.	Class II	P
27.2	Add the following paragraph to the requirement: These requirements are not applicable to class II appliances and class III appliances that incorporate an earth for functional purposes.		N/A
27.3	Add the following paragraph to the requirement: These requirements are not applicable to class II appliances and class III appliances that incorporate an earth for functional purposes.		N/A
27.4	Add the following paragraph to the requirement: These requirements are not applicable to class II appliances and class III appliances that incorporate an earth for functional purposes.		N/A
27.5	Add the following paragraph to the requirement:  These requirements are not applicable to class II appliances and class III appliances that incorporate an earth for functional purposes.		N/A
	Replace existing Note 1 by the following as an addition to the existing second paragraph of the test specification. The test is carried out until steady conditions have been established.		N/A
	Replace existing Note 2 by the following as an addition to the last paragraph of the test specification. The resistance of the supply cord is not included in the resistance calculation.		N/A
	Renumber existing Note 3 as Note.		N/A
27.6	Add the following sentence to the requirement: This requirement is not applicable to class II appliances and class III appliances that incorporate an earth for functional purposes.		N/A
28	Screws and connections		—
28.2	In the second paragraph of the requirement, replace bullets with dashes in the two bulleted items.		N/A
29	CLEARANCES, CREEPAGE DISTANCES AND SOLID INSULATION		—
29.1	Add the following as a new second paragraph of the requirement: For appliances intended for use at altitudes exceeding 2 000 m, the clearances in Table 16 shall be increased according to the relevant multiplier values in Table A.2 of IEC 60664-1.		N/A
	Add the following to the existing second paragraph of the requirement: or to appliances intended for use at altitudes exceeding 2 000 m.		N/A

**Attachment 1**

IEC 60335-1:2010/A1:2013			
Clause	Requirement - Test	Result - Remark	Verdict
	Table 17 – Minimum creepage distances for basic insulation		—
	Replace Note 1 by the following: Lacquered conductors of windings are considered to be bare conductors but creepage distances for basic insulation in other than a double insulation construction need not be greater than the associated clearance specified in Table 16 taking into account 29.1.1.		P
29.3	Replace the third dashed item by the following: – for insulation, other than single layer internal wiring insulation, by an assessment of the thermal quality of the material combined with an electric strength test, in accordance with 29.3.3 and for accessible parts of reinforced insulation consisting of a single layer, by measurement in accordance with 29.3.4, or		N/A
	Add the following as the fourth dashed item of the test specification: – by an assessment of the thermal quality of the material according to 29.3.3 combined with an electric strength test in accordance with 23.5, for each single layer internal wiring insulation touching each other, or		N/A

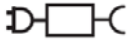
<b>ANNEX B</b>	<b>Appliances powered by rechargeable batteries that are recharged in the appliance</b>		—
	Replace the introductory text		—
7	Marking and instructions		—
7.1	Add the following: Appliances intending to be supplied from a detachable supply unit for the purposes of recharging the battery shall be marked with symbol IEC 60417-6181 (2013-03) and its type reference along with symbol ISO 7000-0790 (2004-01) or with the substance of the following: Use only with <model designation> supply unit		N/A
7.6	Add the following:		N/A
	 [symbol IEC 60417-6181 (2013-03)] detachable supply unit		N/A
7.12	Add the following: For appliances intending to be supplied from a detachable supply unit for the purposes of recharging the battery, the type reference of the detachable supply unit shall be stated along with the substance of the following: WARNING: For the purposes of recharging the battery, only use the detachable supply unit provided with this appliance.		N/A
	If the symbol for detachable supply unit is used, its meaning shall be explained.		N/A



**Attachment 1**

<b>IEC 60335-1:2010/A1:2013</b>			
Clause	Requirement - Test	Result - Remark	Verdict
7.15	Add the following: The type reference of the detachable supply unit shall be placed in close proximity to the symbol.		N/A
11	Heating		—
11.8	The temperature rise of the battery surface shall not exceed the temperature rise limit in the battery manufacturer's specification for the type of battery supplied. If no limit is specified, the temperature rise shall not exceed 20 K.		N/A
19	Abnormal operation		—
19.13	The battery shall not rupture or ignite.		N/A

<b>ANNEX H</b>	<b>Switches</b>		—
20	Clearances, creepage distances, solid insulation and coatings of rigid printed board assemblies		—
	Replace the text by the following: Clause 20 is applicable to clearances across full disconnection and micro-disconnection. It is also applicable to creepage distances for functional insulation, across full disconnection and micro-disconnection, as stated in Table 24.		N/A

<b>ANNEX S</b>	<b>Battery-operated appliances powered by batteries that are non-rechargeable or not recharged in the appliance</b>		—
5	General conditions for the tests		—
5.8.1	Where the supply terminals for the connection of the battery have no indication of polarity, the more unfavourable polarity shall be applied.		N/A
5.S.101	Battery-operated appliances intended for use with a battery box are tested with the battery box supplied with the appliance or with the battery box recommended in the instructions.		N/A
5.S.102	Battery-operated appliances are tested as motor-operated appliances.		N/A
7	Marking and instructions		—
7.1	Battery-operated appliances shall be marked with the battery voltage and the polarity of the terminals unless the polarity is irrelevant.		N/A
	Battery-operated appliances shall also be marked with the <ul style="list-style-type: none"> <li>– name, trade mark or identification mark of the manufacturer or responsible vendor;</li> <li>– model or type reference;</li> <li>– IP number according to degree of protection against ingress of water, other than IPX0;</li> <li>– type reference of battery or batteries.</li> </ul>		N/A

**Attachment 1**

IEC 60335-1:2010/A1:2013			
Clause	Requirement - Test	Result - Remark	Verdict
	If relevant, the positive terminal shall be indicated by the symbol IEC 60417-5005 (2002-10) and the negative terminal by the symbol IEC 60417-5006 (2002-10).		N/A
	If appliances use more than one battery, they shall be marked to indicate correct polarity connection of the batteries.		N/A
	NOTE 1 Examples of acceptable marking representing three batteries are shown in Figure S.1.		N/A
	NOTE 2 It is not necessary for the rated current or rated power input to be marked.		N/A
7.6	<p>⊕ [symbol IEC 60417-5005 (2002-10)] plus; positive polarity</p> <p>⊖ [symbol IEC 60417-5006 (2002-10)] minus; negative polarity</p>		N/A
7.12	<p>The instructions for battery-operated appliances shall contain the substance of the following, as applicable:</p> <ul style="list-style-type: none"> <li>– the types of batteries that may be used;</li> <li>– how to remove and insert the batteries;</li> <li>– non-rechargeable batteries are not to be recharged;</li> <li>– rechargeable batteries are to be removed from the appliance before being charged;</li> <li>– different types of batteries or new and used batteries are not to be mixed;</li> <li>– batteries are to be inserted with the correct polarity;</li> <li>– exhausted batteries are to be removed from the appliance and safely disposed of;</li> <li>– if the appliance is to be stored unused for a long period, the batteries should be removed;</li> <li>– the supply terminals are not to be short-circuited.</li> </ul>		N/A
11	Heating		—
11.5	<p>By means of an external power supply, battery-operated appliances are supplied at the terminals for the connection of the battery with the most unfavourable supply voltage between</p> <ul style="list-style-type: none"> <li>– 0,55 and 1,0 times the battery voltage, if the appliance can be used with non-rechargeable batteries;</li> <li>– 0,75 and 1,0 times battery voltage, if the appliance is designed for use with rechargeable batteries only.</li> </ul>		N/A
	The values specified in Table S.101 for the internal resistance per cell of the battery shall be taken into account.		N/A
19	Abnormal operation		—

**Attachment 1**

IEC 60335-1:2010/A1:2013			
Clause	Requirement - Test	Result - Remark	Verdict
19.1	For battery-operated appliances, the tests are carried out with the battery fully charged unless otherwise specified.		N/A
19.13	The battery shall not rupture or ignite.		N/A
19.S.101	Battery-operated appliances are supplied with the voltage specified in 11.5. The supply terminals having an indication of polarity are connected to the opposite polarity, unless such a connection is unlikely to occur due to the construction of the appliance.		N/A
19.S.102	For battery-operated appliances with provision for multiple batteries, one or more of the batteries shall be reversed and the appliance shall be operated, if reversal of batteries is allowed by the construction.		N/A
25	Supply connection and external flexible cords		—
25.5	The flexible leads or flexible cord used to connect an external battery or battery box in battery-operated appliances shall be connected to the appliance by a type X attachment.		N/A
25.13	This requirement is not applicable to the flexible leads or flexible cord connecting external batteries or a battery box with an appliance.		N/A
25.S.101	Battery-operated appliances shall have suitable means for connection of the battery. If the type of battery is marked on the appliance, the means of connection shall be suitable for this type of battery.		N/A
26	Terminals for external conductors		—
26.5	Terminal devices in an appliance for the connection of the flexible leads or flexible cord connecting an external battery or battery box shall be so located or shielded that there is no risk of accidental connection between supply terminals.		N/A
30	Resistance to heat and fire		—
30.2.3.2	Addition: There shall be no battery in the area of the vertical cylinder used for the consequential needle flame test unless the battery is shielded by a barrier that meets the needle flame test of Annex E or that comprises material classified as V-0 or V-1 according to IEC 60695-11-10 provided that the test sample used for the classification was no thicker than the relevant part of the appliance.		N/A

--- End of Attachment 1 ---

## Attachment 2

IEC60335_2_80E - ATTACHMENT			
Clause	Requirement - Test	Result - Remark	Verdict

<b>ATTACHMENT TO TEST REPORT IEC 60335-2-80</b> <b>EUROPEAN GROUP DIFFERENCES AND NATIONAL DIFFERENCES</b> (Part 2: Particular requirements for fans)	
<b>Differences according to:</b>	EN 60335-1:2012 EN 60335-2-80:2003+A1:2004+A2:2009 EN 62233:2008
<b>Attachment Form No.:</b>	EU_GD_IEC60335_2_80E
<b>Attachment Originator:</b>	DEKRA Certification B.V.
<b>Master Attachment:</b>	2012-09
<b>Copyright © 2012 IEC System for Conformity Testing and Certification of Electrical Equipment (IECEE), Geneva, Switzerland. All rights reserved.</b>	

CENELEC COMMON MODIFICATIONS			
6.1	Delete "class 0" and "class 01"		P
7.1	Single-phase appliances to be connected to the supply mains: 230 V covered		P
	Multi-phase appliances to be connected to the supply mains: 400 V covered		N/A
7.10	Devices used to start/stop operational functions of the appliance distinguished from other manual devices by means of shape, size, surface texture, position, etc.		P
	An indication that the device has been operated is given by:		--
	• a tactile feedback, or		P
	• an audible and visual feedback		P
7.12	The instructions include the substance of the following:		--
	- this appliance can be used by children aged from 8 years and above and persons with reduced physical, sensory or mental capabilities or lack of experience and knowledge if they have been given supervision or instruction concerning use of the appliance in a safe way and understand the hazards involved		P
	- children shall not play with the appliance		P
	- cleaning and user maintenance shall not be made by children without supervision		P

## Attachment 2

IEC60335_2_80E - ATTACHMENT			
Clause	Requirement - Test	Result - Remark	Verdict
7.12.Z1	The specific instructions related to the safe operation of this appliance is collated together in the front section of the user instructions		P
	The height of the characters, measured on the capital letters, is at least 3 mm		P
	These instructions are also available in an alternative format, e.g. on a website		P
8.1.1	Also test probe 18 of EN 61032 is applied		P
	The appliance being in every possible position during the test		P
	The force on the probe in the straight position is increased to 10 N when probe 18 is used		P
	When using test probe 18 the appliance is fully assembled as in normal use without any parts removed, and		P
	parts intended to be removed for user maintenance are also not removed		P
8.2	Compliance is checked by applying the test probes of EN 61032		P
	For built-in appliances and fixed appliances, the test probe B and probe 18 of EN 61032 are applied only after installation	Portable appliance	N/A
11.8	Footnotes to "External enclosure of motor-operated appliances" to be taken into account		P
15.1.2	Appliances with an automatic cord reel tested with the cord in the most unfavourable position so that the reeling of the wet cord may affect electrical insulation during operation, the cord not being dried before reeling		N/A
20.2	When using the test probe similar to test probe B with a circular stop face, the accessories and detachable covers are removed		P
	Test probe 18 applied with a force of 2,5N on the appliance fully assembled		P
24.1	Components comply with the safety requirements specified in the relevant standards as far as they reasonably apply		P

## Attachment 2

IEC60335_2_80E - ATTACHMENT			
Clause	Requirement - Test	Result - Remark	Verdict
	The requirements of Clause 29 of this standard apply between live parts of components and accessible parts of the appliance.		P
	The requirements of 30.2 of this standard apply to parts of non-metallic material in components including parts of non-metallic material supporting current-carrying connections inside components		P
	Components that have not been previously tested or do not comply with the standard for the relevant component are tested according to the requirements of 30.2		P
	Components that have been previously tested and shown to comply with the resistance to fire requirements in the standard for the relevant component need not be retested provided that:		--
	- the severity specified in the component standard is not less than the severity specified in 30.2, and		N/A
	- the test report for the component states whether it complied with the standard for the relevant component with or without flame, flames not exceeding 2 s during the test are ignored		N/A
	Unless components have been previously tested and found to comply with the relevant standard for the number of cycles specified, they are tested in accordance with 24.1.1 to 24.1.9		P
	For components mentioned in 24.1.1 to 24.1.9, no additional tests specified in the relevant standard for the component are necessary other than those specified in 24.1.1 to 24.1.9		N/A
	Components that have not been separately tested and found to comply with the relevant standard, and		P
	components that are not marked or not used in accordance with their marking,		P
	are tested in accordance with the conditions occurring in the appliance, the number of samples being that required by the relevant standard		P

## Attachment 2

IEC60335_2_80E - ATTACHMENT			
Clause	Requirement - Test	Result - Remark	Verdict
	Lamp holders and starter holders that have not been previously tested and found to comply with the relevant standard are tested as a part of the appliance and additionally comply with the gauging and interchangeability requirements of the relevant standard under the conditions occurring in the appliance	No such part	N/A
	Where the relevant standard specifies these gauging and interchangeability requirements at elevated temperatures, the temperatures measured during the tests of Clause 11 are used		N/A
	Plugs and socket-outlets and other connecting devices of interconnection cords are not interchangeable with plugs and socket-outlets listed in IEC/TR 60083 or IEC 60906-1, or		N/A
	with connectors and appliance inlets complying with the standard sheets of IEC 60320-1,		N/A
	if direct supply to these parts from the supply mains gives rise to a hazard		N/A
24.1.7	If the remote operation of the appliance is via a telecommunication network, the relevant standard for the telecommunication interface circuitry in the appliance is EN 41003		N/A
	Compliance with Clause 8 of this standard is not impaired by connecting the appliance to a device covered by EN 41003		N/A
24.Z1	For motor running capacitors (IEC 60252-1 type P2) with a metallic enclosure having an overpressure fuse the flame testing of internal plastic parts supporting current carrying connections as required in 30.2.2 and 30.2.3.1 is not necessary	No such structure	N/A
25.6	Supply cords of single-phase portable appliances having a rated current not exceeding 16 A, fitted with a plug complying with the following standard sheets of IEC/TR 60083:		--
	- for Class I appliances: standard sheet C2b, C3b or C4 .....		N/A
	- for Class II appliances: standard sheet C5 or C6 .....	C5	P

## Attachment 2

IEC60335_2_80E - ATTACHMENT			
Clause	Requirement - Test	Result - Remark	Verdict
25.7	Rubber sheathed cords (60245 IEC 53) are not suitable for appliances intended to be used outdoors or when they are liable to be exposed to significant amount of ultraviolet radiation		N/A
	Halogen-free thermoplastic compound sheathed supply cords have properties at least those of:		--
	<ul style="list-style-type: none"> <li>halogen-free thermoplastic compound sheathed cords (H03Z1Z1H2-F or H03Z1Z1-F), for appliances having a mass not exceeding 3 kg</li> </ul>		N/A
	<ul style="list-style-type: none"> <li>halogen-free thermoplastic compound sheathed cords (H05Z1Z1H2-F or H05Z1Z1-F), for other appliances</li> </ul>		N/A
	Cross-linked halogen-free compound sheathed supply cords have properties at least those of cross-linked halogen-free compound sheathed cords (H07ZZ-F)		N/A
26.11	Conductors connected by soldering are not considered to be positioned or fixed so that reliance is not placed upon the soldering alone to maintain them in position unless they are held in place near the terminals independently of the solder		P
29.3.Z1	Appliance constructed so that if there is a possibility of damaging the insulation during installation, the insulation withstands the scratch and penetration test of 21.2		N/A
32	Compliance regarding electromagnetic fields is checked according to EN 50366 or EN 62233	EN 62233: 2008	P
Annex I, 19.1.101	The appliance is supplied at rated voltage and operated under normal operation with each of the fault conditions specified		N/A
	The duration of the test is as specified in 19.7		N/A
<b>ZA</b>	<b>ANNEX ZA (NORMATIVE) SPECIAL NATIONAL CONDITIONS</b>		--
	<b>Norway</b>		--
19.5	The test is also applicable to appliances intended to be permanently connected to fixed wiring		Not check
	<b>Norway</b>		--



## Attachment 2

IEC60335_2_80E - ATTACHMENT			
Clause	Requirement - Test	Result - Remark	Verdict
22.2	The second paragraph of this subclause, dealing with single-phase, permanently connected class I appliances having heating elements, is not applicable due to the supply system		Not check
	<b>All CENELEC countries</b>		--
25.6 and 25.25	Information concerning National plug and socket-outlets is available from the CENELEC website. Normative national requirements concerning plug and socket-outlets are shown in the relevant National standard		P
	<b>Ireland and United Kingdom</b>		--
25.8	In the table, the lines for 10 A and 16 A are replaced by:		--
	> 10 and ≤ 13 1,25		Not check
	> 13 and ≤ 16 1,5		Not check
<b>ZB</b>	<b>ANNEX ZB (INFORMATIVE) A-DEVIATIONS</b>		--
	<b>Ireland</b>		--
25.6	These regulations apply to all plugs for domestic use at a voltage of not less than 200 V and in general allow only plugs complying with I.S. 401:1997, or equivalent, to be fitted to domestic appliances		Not check
	<b>United Kingdom</b>		--
25.6	These regulations apply to all plugs for domestic use at a voltage of not less than 200 V and in general allow only plugs to BS 1363 to be fitted to domestic appliances. It also allows plugs to BS 4573 and EN 50075 to be fitted to shavers and toothbrushes		Not check

## Attachment 2

IEC60335_2_80E - ATTACHMENT			
Clause	Requirement - Test	Result - Remark	Verdict
<b>ZC</b>	<b>ANNEX ZC (NORMATIVE) NORMATIVE REFERENCES TO INTERNATIONAL PUBLICATIONS WITH THEIR CORRESPONDING EUROPEAN PUBLICATIONS</b>		--
	A list of referenced documents in this standard		P
<b>ZD</b>	<b>ANNEX ZD (INFORMATIVE) IEC and CENELEC CODE DESIGNATIONS FOR FLEXIBLE CORDS</b>		--
	A table with IEC and CENELEC code designations for flexible cords		P
<b>ZE</b>	<b>ANNEX ZE (INFORMATIVE) SPECIFIC ADDITIONAL REQUIREMENTS FOR APPLIANCES AND MACHINES INTENDED FOR COMMERCIAL USE</b>		--
7.1	Business name and full address of the manufacturer and, where applicable, his authorized representative.....:		N/A
	Model or type reference .....		N/A
	Serial number, if any .....		N/A
	Production year		N/A
	Designation of the appliance.....:		N/A
7.12	Instructions provided with the appliance so that the appliance can be used safely		N/A
	The instructions contain at least the following information:		N/A
	- the business name and full address of the manufacturer and, where applicable, his authorized representative		N/A
	- model or type reference of the appliance as marked on the appliance itself, except for the serial number		N/A
	- the designation of the appliance together with its explanation in case it is given by a combination of letters and/or numbers		N/A
	- the general description of the appliance, when needed due to the complexity of the appliance		N/A
	- specific precautions if required during installation, operation, adjusting, user maintenance, cleaning, repairing or moving		N/A

## Attachment 2

IEC60335_2_80E - ATTACHMENT			
Clause	Requirement - Test	Result - Remark	Verdict
	- when needed drawings, diagrams, descriptions and explanations necessary for the safe use and user maintenance of the appliance		N/A
	- the possible reasonably foreseeable misuse and, whenever relevant, a warning against the effects it may have on the safe use of the appliance		N/A
	The words "Original instructions" appear on the language version(s) verified by the manufacturer or by the authorized representative		N/A
	When a translation of the original instructions has been provided by a person introducing the appliance on the market; the meaning of the sentence "Translation of the original instructions" appear in the relevant instructions delivered with the appliance		N/A
	The instructions for maintenance/service to be done by specialized personnel, mandated by the manufacturer or the authorized representative may be supplied in only one Community language which the specialized personnel understand		N/A
	The instructions indicate the type and frequency of inspections and maintenance required for safe operation including the preventive maintenance measures		N/A
7.12.ZE1	If needed for specific appliances, the following information to be given:		N/A
	<ul style="list-style-type: none"> <li>on use, transportation, assembly, dismantling when out of service, testing or foreseeable breakdowns, if these operations have consequences on stability of the appliance in order to avoid overturning, falling or uncontrolled movements of the appliance or of its component parts</li> </ul>		N/A
	<ul style="list-style-type: none"> <li>on how to maintain adequate mechanical stability when in use, during transportation, assembly, dismantling, scrapping and any other action involving the appliance</li> </ul>		N/A
	<ul style="list-style-type: none"> <li>on the protective measures to be taken by the user, including, where appropriate, the personal protective equipment to be provided</li> </ul>		N/A

## Attachment 2

IEC60335_2_80E - ATTACHMENT			
Clause	Requirement - Test	Result - Remark	Verdict
	<ul style="list-style-type: none"> <li>on the operating method to be followed in the event of accident or breakdown; if a blockage is likely to occur the operating method to safely unblock the appliance</li> </ul>		N/A
	<ul style="list-style-type: none"> <li>on the specifications on the spare parts to be used, when these affect the health and safety of the operator</li> </ul>		N/A
	<ul style="list-style-type: none"> <li>on airborne noise emissions, determined and declared in accordance with the relevant Part 2, which includes:</li> </ul>		N/A
	- the A-weighted emission sound pressure level at workstations, where this exceeds 70 dB(A) .....		N/A
	- where this level does not exceed 70 dB(A), this fact is indicated		N/A
	- the peak C-weighted instantaneous sound pressure value at workstations, where this exceeds 63 Pa (130 dB in relation to 20 µPa).....		N/A
	- the A-weighted sound power level emitted by the machinery, where the A-weighted emission sound pressure level at workstations exceeds 80 dB(A) .....		N/A
7.12.ZE2	The instructions includes a warning to disconnect the appliance from its power source during service and when replacing parts		N/A
	If the removal of the plug is foreseen, it is clearly indicated that the removal of the plug has to be such that an operator can check from any of the points to which he has access that the plug remains removed		N/A
	If this is not possible, due to the construction of the appliance or its installation, a disconnection with a locking system in the isolated position is provided		N/A
19.11.4.8	The appliance continues to operate, without causing any hazard to the user, from the same point in its operating cycle at which the voltage fluctuation occurred, or		N/A
	a manual operation is required to restart it		N/A

## Attachment 2

IEC60335_2_80E - ATTACHMENT			
Clause	Requirement - Test	Result - Remark	Verdict
20.1	Appliances and their components and fittings have adequate mechanical stability during transportation, assembly, dismantling and any other action involving the appliance		N/A
20.2	Dangerous moving transmission parts safeguarded either by design or guards		N/A
	When guards are used, they are fixed guards, interlocking movable guards or protective devices		N/A
	Moving parts directly involved in the function of the appliance which cannot be made completely inaccessible fitted with:		N/A
	- fixed guards or interlocking movable guards preventing access to those sections of the parts that are not used in the work, and		N/A
	- adjustable guards restricting access to those sections of the moving parts where access is necessary		N/A
	Interlocking movable guards used where frequent access is required		N/A
21.1	Appliances and their components and fittings have adequate mechanical strength and is constructed to withstand such rough handling that may be expected in normal use, during transportation, assembly, dismantling, scrapping and any other action involving the appliance		N/A
22.ZE.1	For appliances provided with a seat, the seat gives adequate stability		N/A
	The distance between the seat and the control devices capable of being adapted to the operator		N/A
22.ZE.2	For appliances provided with separate devices for the start and the stop functions, the stop function is unambiguously identifiable and does always override the start function		N/A
	For appliances provided with one device performing the start and the stop function, the stop function is unambiguously identifiable and does always override the start function		N/A
22.ZE.3	Appliances designed in such a way that incorrect mounting is avoided, if this can lead to an unsafe situation		N/A

## Attachment 2

IEC60335_2_80E - ATTACHMENT			
Clause	Requirement - Test	Result - Remark	Verdict
	If this is not possible, information on the correct mounting is given directly on the part and/or the enclosure		N/A
22.ZE.4	Where the weight, size or shape prevents appliances from being moved manually, they are fitted with attachments for lifting gear, or		N/A
	so designed that they can be fitted with such attachments, or		N/A
	be shaped in such a way that standard lifting gear can easily be used		N/A
	Appliances to be moved manually are constructed or equipped so that they can be moved easily and safely		N/A
22.ZE.5	The fixing systems of fixed guards which prevent access to dangerous moving transmission parts only removable with the use of tools		N/A
	If such guards have to be removed by the user for routine cleaning or maintenance their fixing systems remain attached to the fixed guards or to the machine after removal		N/A
	Where possible, guards are incapable of remaining in place without their fixings		N/A
	This does not apply if, after removal of the screws, or if the component is incorrectly repositioned, the appliance becomes inoperative		N/A
	Movable guards are interlocked		N/A
	The interlocking devices prevent the start of hazardous appliance functions until the guards are fixed in their position, and give a stop command whenever they are no longer closed		N/A
	Where it is possible for an operator to reach the danger zone before the risk due to hazardous appliance functions has ceased, movable guards associated with a guard locking device in addition to an interlocking device that:		N/A
	- prevents the start of hazardous appliance functions until the guard is closed and locked, and		N/A
	- keeps the guard closed and locked until the risk of injury from the hazardous appliance functions has ceased		N/A
	Interlocking movable guards remain attached to the appliance when open, and		N/A

## Attachment 2

IEC60335_2_80E - ATTACHMENT			
Clause	Requirement - Test	Result - Remark	Verdict
	they are designed and constructed in such a way that they can be adjusted only by means of an intentional action		N/A
22.ZE.6	Interlocking movable guards designed in such a way that the absence or failure of one of their components prevents starting or stops the hazardous appliance functions		N/A
	The guard is opened to the extent needed to cause the interlocking to operate and is then closed, the number of operations being defined in the specific Part 2.....:		N/A
	After this test any defect that may be expected in normal use is applied to the interlock system, including interruption of the supply, only one defect being simulated at a time		N/A
	After these tests the interlock system is fit for further use		N/A
22.ZE.7	Adjustable guards restricting access to areas of the moving parts strictly necessary for the work are:		N/A
	- adjustable manually or automatically, depending on the type of work involved, and		N/A
	- readily adjustable without the use of tools		N/A
22.ZE.8	In case of interruption, re-establishment after an interruption or fluctuation in whatever manner of the power supply, the appliance does not restart		N/A
	However, automatic restarting of the operation is allowed if the appliance may continue to operate, without causing any hazard to the user, from the same point in its operating cycle at which the voltage interruption or fluctuation occurred		N/A
22.ZE.9	Appliances fitted with means to isolate them from all energy sources		N/A
	Such isolators are clearly identified, and		N/A
	they are capable of being locked if reconnection endanger persons		N/A
	After the energy source is disconnected, it is possible to dissipate any energy remaining or stored in the circuits of the appliance without risk to persons		N/A

**Attachment 2**

IEC60335_2_80E - ATTACHMENT			
Clause	Requirement - Test	Result - Remark	Verdict
<b>ZF</b>	<b>ANNEX ZF (INFORMATIVE) CRITERIA APPLIED FOR THE ALLOCATION OF PRODUCTS COVERED BY STANDARDS IN THE EN 60335 SERIES UNDER LVD OR MD</b>		--
	List of standards under CENELEC/TC61 with the allocation under the LVD (Low Voltage Directive) or the MD (Machinery Directive).....:		P
<b>ZG</b>	<b>ANNEX ZG (NORMATIVE) UV APPLIANCES</b>		--
	The following modifications to this standard apply to appliances having UV emitters		N/A
	This annex is not applicable to appliances covered by the scopes of IEC 60335-2-27, IEC 60335-2-59 or IEC 60335-2-109		N/A
7.12.ZG	The instructions for appliances incorporating UVC emitters include the substance of the following: WARNING — This appliance contains a UV emitter. Do not stare at the light source		N/A
32	For appliances incorporating UV emitters the manufacturer delivers a declaration providing evidence that the plastic material exposed to the radiation is UV resistant		N/A
<b>ZZ</b>	<b>ANNEX ZZ (INFORMATIVE) COVERAGE OF ESSENTIAL REQUIREMENTS OF EC DIRECTIVES</b>		--
	Description of the relation between this European standard and the LVD (Low Voltage Directive, 2006/95/EC) and the MD (Machinery Directive, 2006/42/EC)		P

<b>Annex EN 62233:2008</b>			
Clause	Requirement + Test	Result - Remark	Verdict
<b>EMF- ELECTROMAGNETICS FIELDS</b>			
	The tested product also complies with the requirements of EN 62233:2008		P
	Limit .....100%	Measured max. 1,503 % (TX-1208A); 1,438 % (TX-1808A); 1,557 % (TX-1610R)	P



### Attachment 3

Clause	Requirement - Test	Result - Remark	Verdict
--------	--------------------	-----------------	---------

<b>ATTACHMENT TO TEST REPORT IEC 60335-1</b> <b>Household and similar electrical appliances – Safety –</b> <b>Part 1: General requirements</b>	
<b>Differences according to:</b>	EN 60335-1:2012/ A11: 2014
<b>Attachment Form No.:</b>	EN 60335-1/A11
<b>Attachment Originator:</b>	SGS-CSTC
<b>Master Attachment:</b>	Date 2014-09

7.14	In NOTE Z1, replace "IEC 82079-1" by "EN 82079-1".		N/A
Annex ZF	In Table ZF.1 – List of standards under CLC/TC 61, replace line of EN 60335-2-38 by the following: EN 60335-2-38, Commercial electric griddles and griddle grills with moving parts		N/A

--- End of Attachment 3 ---

## Attachment 4

### Photo documentation

Type of equipment / model: Electric Fan / TX-1208, TX-1208A, TX-1208B, TX-1608, TX-1608A, TX-1608B, TX-1608V, TX-1609, TX-1611, TX-1608BR, TX-1608VR, TX-1610R, TX-1611R, TX-1808A, TX-1811

---

Details of: TX-1208

---

View:

- general
- front
- rear
- right
- left
- top
- bottom
- internal

A photograph showing the front view of a white electric fan. The fan has a circular grille and is mounted on a white stand with four legs. A power cord is visible. A black L-shaped ruler is placed on the surface next to the fan for scale.

Details of: TX-1208

---

View:

- general
- front
- rear
- right
- left
- top
- bottom
- internal

A photograph showing the general view of the electric fan's motor and housing. The motor is white and cylindrical, with a power cord attached. A black L-shaped ruler is placed on the surface next to the motor for scale.

## Attachment 4

Details of: TX-1208

---

View:

- general
- front
- rear
- right
- left
- top
- bottom
- internal



Details of: TX-1208, control panel

---

View:

- general
- front
- rear
- right
- left
- top
- bottom
- internal



## Attachment 4

Details of: TX-1208

---

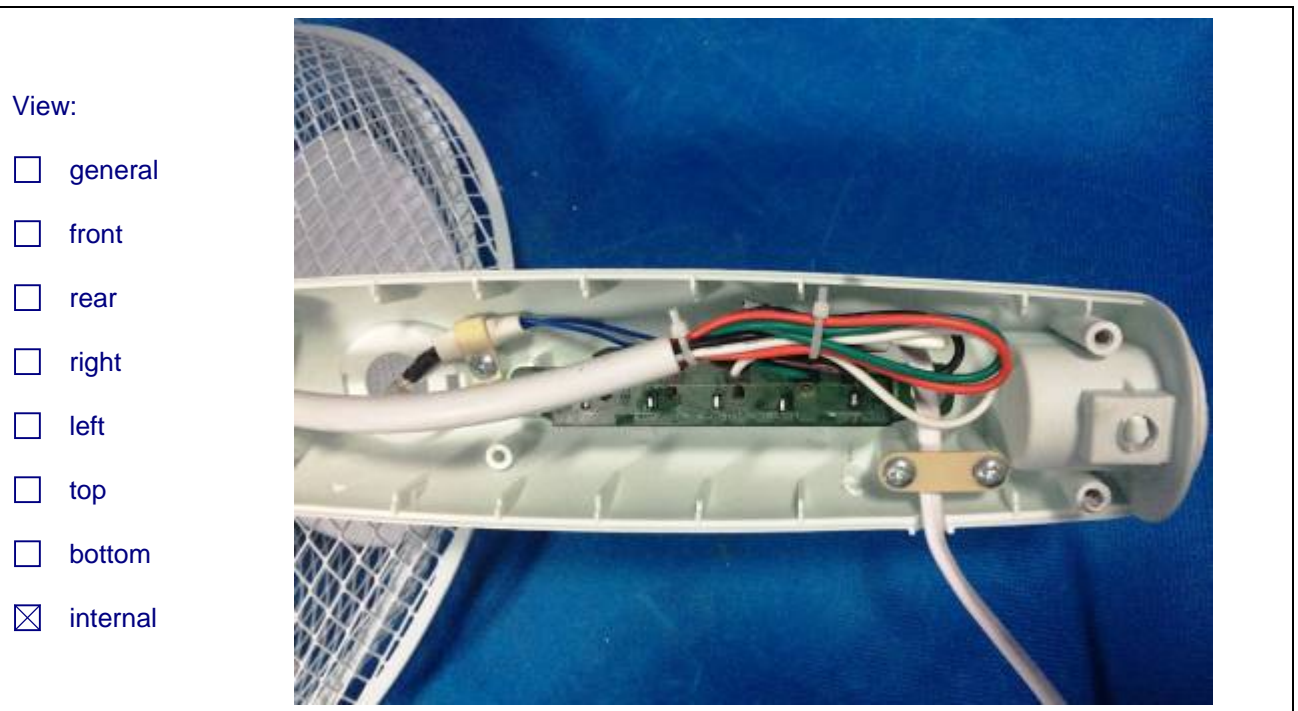

Details of: TX-1208A

---



## Attachment 4

Details of: TX-1208A

---

View:

- general
- front
- rear
- right
- left
- top
- bottom
- internal



Details of: TX-1208A

---

View:

- general
- front
- rear
- right
- left
- top
- bottom
- internal



## Attachment 4

Details of: TX-1208A, control panel

---

View:

- general
- front
- rear
- right
- left
- top
- bottom
- internal



Details of: TX-1208A

---

View:

- general
- front
- rear
- right
- left
- top
- bottom
- internal

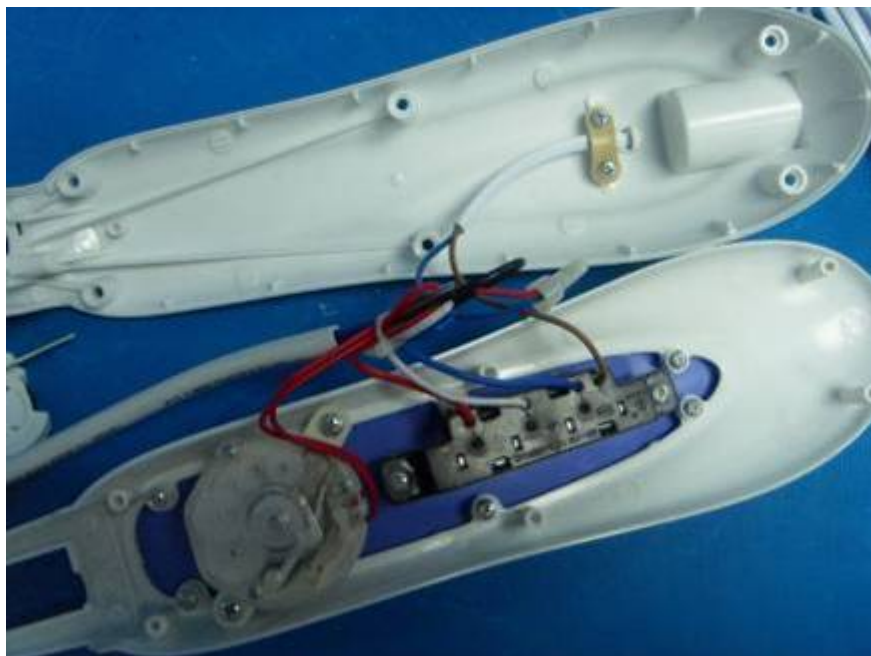

## Attachment 4

Details of: TX-1208A

View:

- general
- front
- rear
- right
- left
- top
- bottom
- internal



Details of: Motor, M-1208

View:

- general
- front
- rear
- right
- left
- top
- bottom
- internal



## Attachment 4

Details of: TX-1208B

---

View:

- general
- front
- rear
- right
- left
- top
- bottom
- internal



Details of: TX-1208B

---

View:

- general
- front
- rear
- right
- left
- top
- bottom
- internal





## Attachment 4

Details of: TX-1208B

---

View:

- general
- front
- rear
- right
- left
- top
- bottom
- internal



Details of: TX-1208B, control panel

---

View:

- general
- front
- rear
- right
- left
- top
- bottom
- internal



## Attachment 4

Details of: TX-1208B

---

View:

- general
- front
- rear
- right
- left
- top
- bottom
- internal

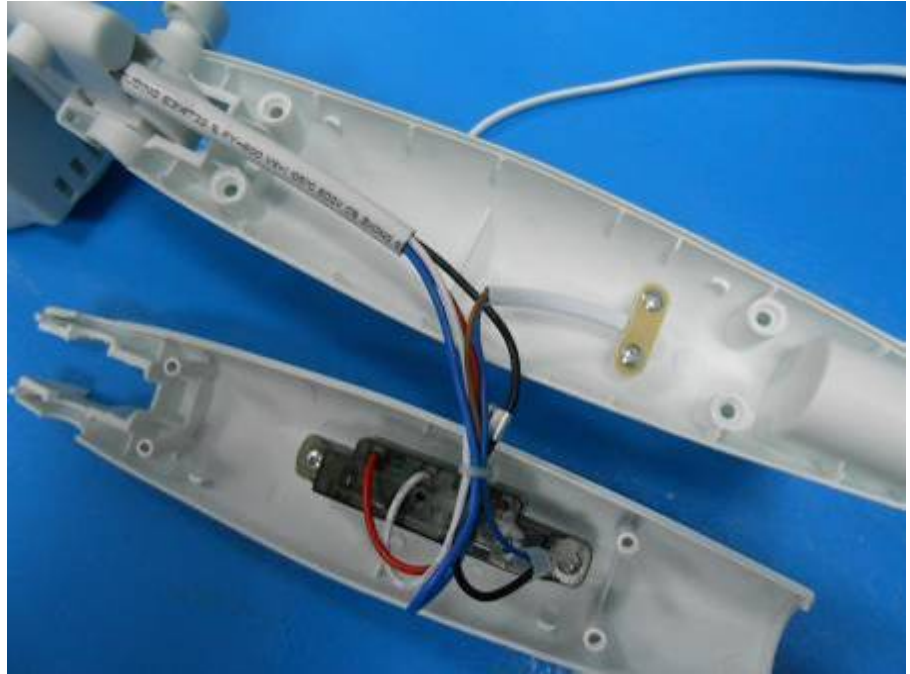

Details of: Alternative fan guard for TX-1208, TX-1208A and TX-1208B

---

View:

- general
- front
- rear
- right
- left
- top
- bottom
- internal



## Attachment 4

Details of: Alternative fan guard for TX-1208, TX-1208A and TX-1208B

View:

- general
- front
- rear
- right
- left
- top
- bottom
- internal



Details of: TX-1608

View:

- general
- front
- rear
- right
- left
- top
- bottom
- internal



## Attachment 4

Details of: TX-1608

---

View:

- general
- front
- rear
- right
- left
- top
- bottom
- internal



Details of: TX-1608

---

View:

- general
- front
- rear
- right
- left
- top
- bottom
- internal



## Attachment 4

Details of: TX-1608

---

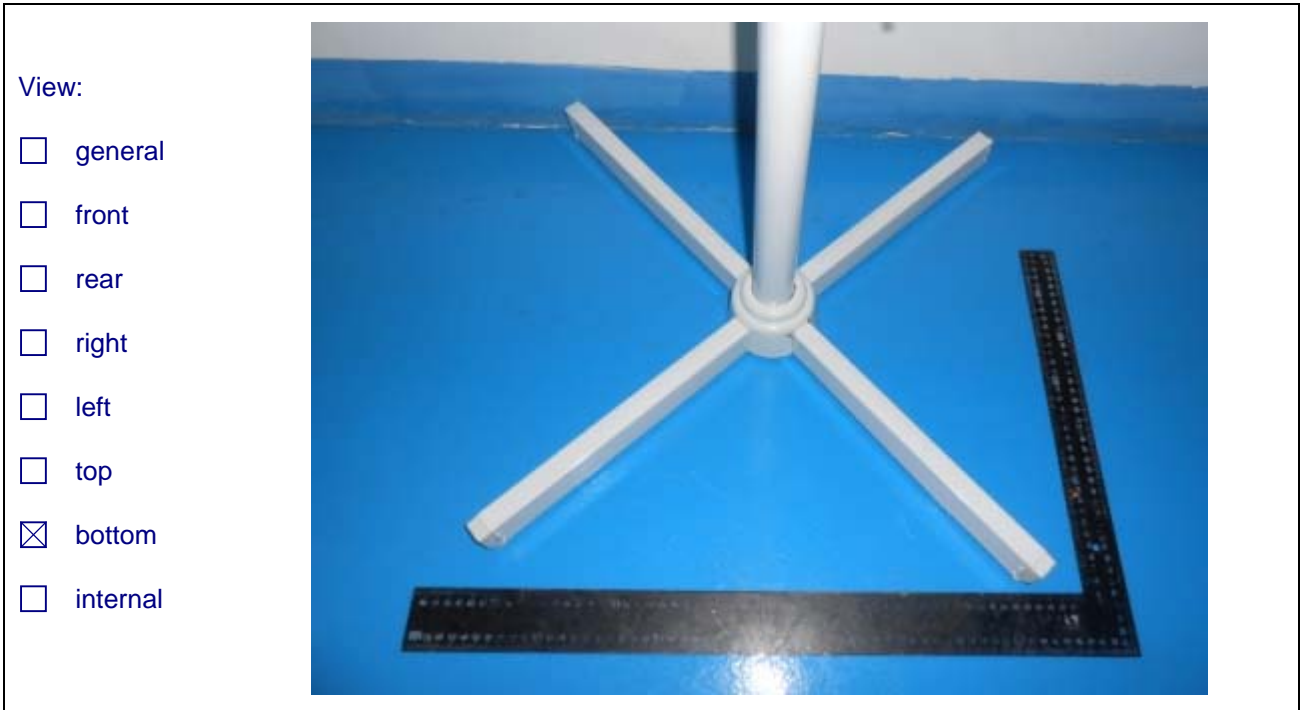

Details of: TX-1608, control panel

---



## Attachment 4

Details of: TX-1608

View:

- general
- front
- rear
- right
- left
- top
- bottom
- internal



Details of: Motor, M-1608

View:

- general
- front
- rear
- right
- left
- top
- bottom
- internal



## Attachment 4

Details of: TX-1608A

---

View:

- general
- front
- rear
- right
- left
- top
- bottom
- internal



Details of: TX-1608A

---

View:

- general
- front
- rear
- right
- left
- top
- bottom
- internal



## Attachment 4

Details of: TX-1608A

---

View:

- general
- front
- rear
- right
- left
- top
- bottom
- internal



Details of: TX-1608A, control panel

---

View:

- general
- front
- rear
- right
- left
- top
- bottom
- internal





## Attachment 4

Details of: TX-1608A

---

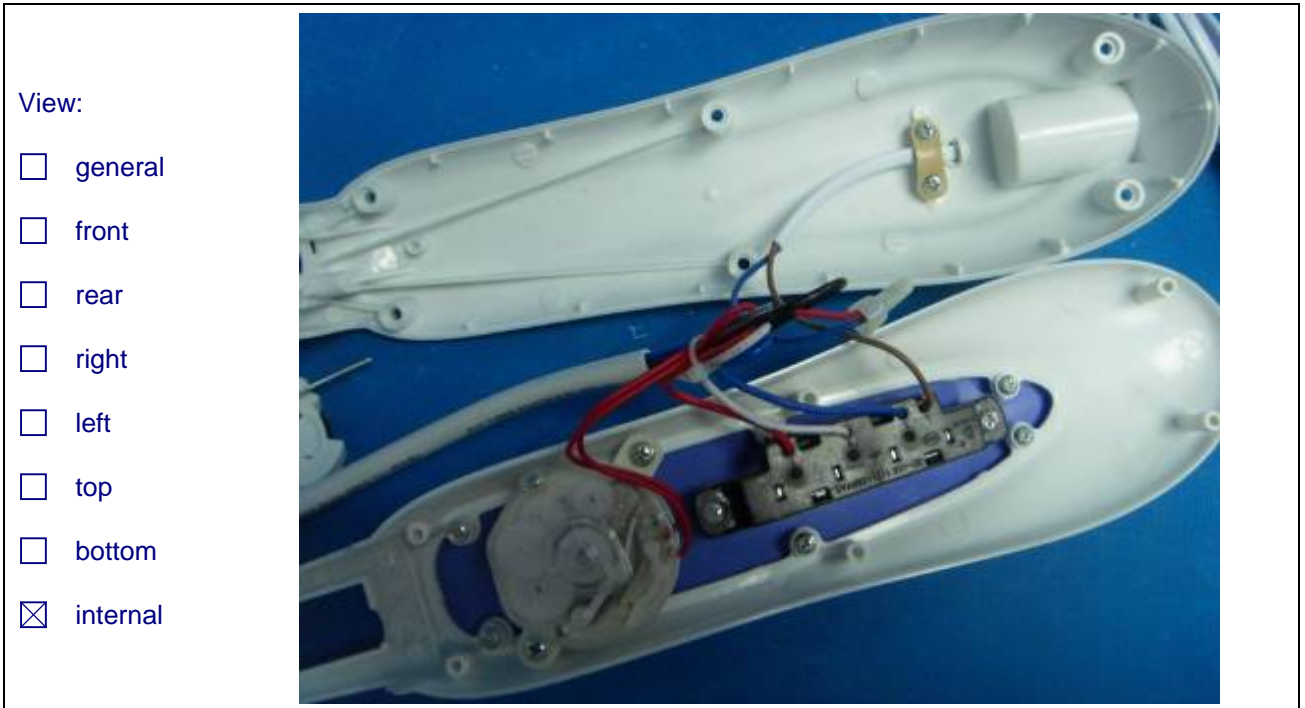

Details of: TX-1608A with alternative fan guard (weight < 3Kg)

---



## Attachment 4

Details of: TX-1608A, alternative fan guard

---

View:

- general
- front
- rear
- right
- left
- top
- bottom
- internal



Details of: TX-1608A, Screw for fan guard

---

View:

- general
- front
- rear
- right
- left
- top
- bottom
- internal



**Attachment 4**

Details of: TX-1608B, control panel

View:

- general
- front
- rear
- right
- left
- top
- bottom
- internal



Details of: TX-1608V

View:

- general
- front
- rear
- right
- left
- top
- bottom
- internal



**Attachment 4**

Details of: TX-1609

View:

- general
- front
- rear
- right
- left
- top
- bottom
- internal



Details of: TX-1611

View:

- general
- front
- rear
- right
- left
- top
- bottom
- internal



## Attachment 4

Details of: TX-1608BR

---

View:

- general
- front
- rear
- right
- left
- top
- bottom
- internal



Details of: TX-1608BR

---

View:

- general
- front
- rear
- right
- left
- top
- bottom
- internal



## Attachment 4

Details of: TX-1608BR

View:

- general
- front
- rear
- right
- left
- top
- bottom
- internal



Details of: TX-1608BR, control panel

View:

- general
- front
- rear
- right
- left
- top
- bottom
- internal



## Attachment 4

Details of: TX-1608BR, control panel

---

View:

- general
- front
- rear
- right
- left
- top
- bottom
- internal



Details of: TX-1608BR, PCB layout

---

View:

- general
- front
- rear
- right
- left
- top
- bottom
- internal



## Attachment 4

Details of: TX-1608BR, PCB

---

View:

- general
- front
- rear
- right
- left
- top
- bottom
- internal



Details of: TX-1608BR with alternative pedestal (weight < 3Kg)

---

View:

- general
- front
- rear
- right
- left
- top
- bottom
- internal





## Attachment 4

Details of: TX-1608BR, alternative pedestal

---

View:

- general
- front
- rear
- right
- left
- top
- bottom
- internal



Details of: TX-1608VR

---

View:

- general
- front
- rear
- right
- left
- top
- bottom
- internal



## Attachment 4

Details of: TX-1610R

---

View:

- general
- front
- rear
- right
- left
- top
- bottom
- internal



Details of: TX-1610R

---

View:

- general
- front
- rear
- right
- left
- top
- bottom
- internal



## Attachment 4

Details of: TX-1610R

View:

- general
- front
- rear
- right
- left
- top
- bottom
- internal



Details of: TX-1610R, control panel

View:

- general
- front
- rear
- right
- left
- top
- bottom
- internal



## Attachment 4

Details of: TX-1610R, control panel

View:

- general
- front
- rear
- right
- left
- top
- bottom
- internal



Details of: TX-1610R

View:

- general
- front
- rear
- right
- left
- top
- bottom
- internal

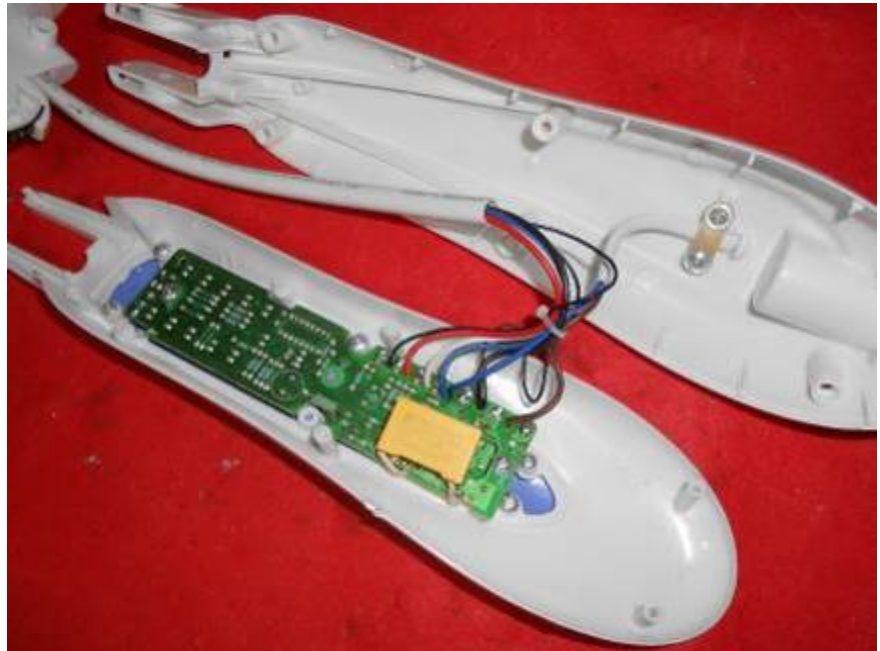

## Attachment 4

Details of: TX-1610R, PCB

---

View:

- general
- front
- rear
- right
- left
- top
- bottom
- internal

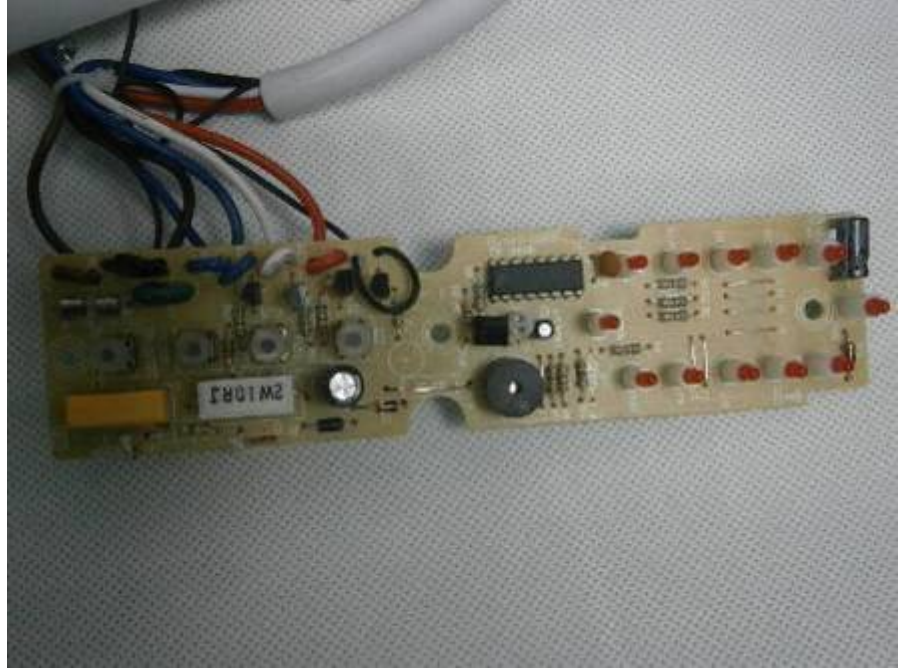

Details of: TX-1610R, PCB layout

---

View:

- general
- front
- rear
- right
- left
- top
- bottom
- internal

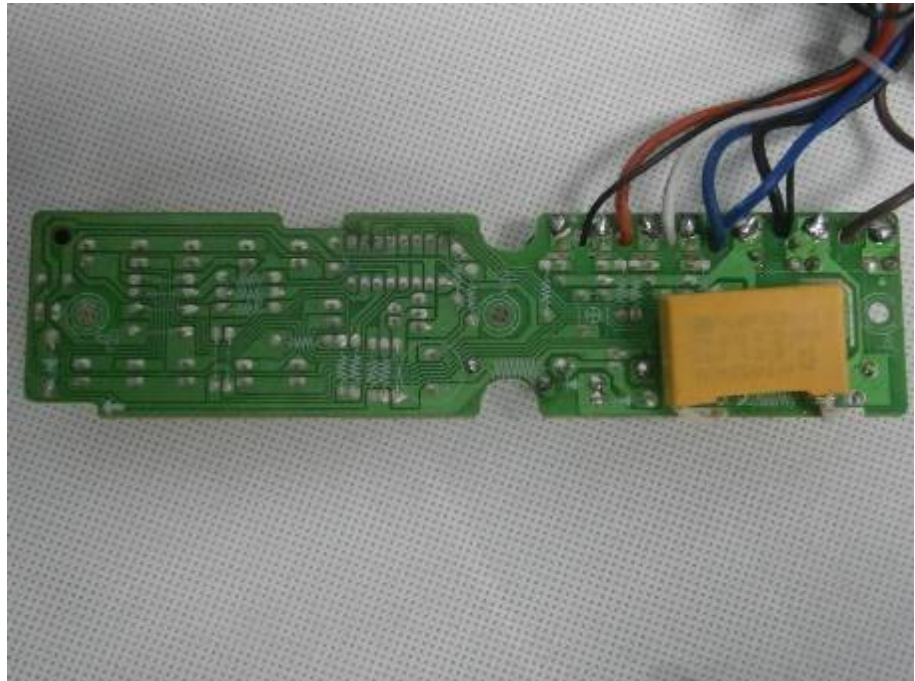

## Attachment 4

Details of: TX-1611R

---

View:

- general
- front
- rear
- right
- left
- top
- bottom
- internal



Details of: TX-1611R

---

View:

- general
- front
- rear
- right
- left
- top
- bottom
- internal



## Attachment 4

Details of: TX-1611R

View:

- general
- front
- rear
- right
- left
- top
- bottom
- internal



Details of: TX-1611R, control panel

View:

- general
- front
- rear
- right
- left
- top
- bottom
- internal



## Attachment 4

Details of: TX-1611R

---

View:

- general
- front
- rear
- right
- left
- top
- bottom
- internal



Details of: TX-1611R, PCB layout

---

View:

- general
- front
- rear
- right
- left
- top
- bottom
- internal

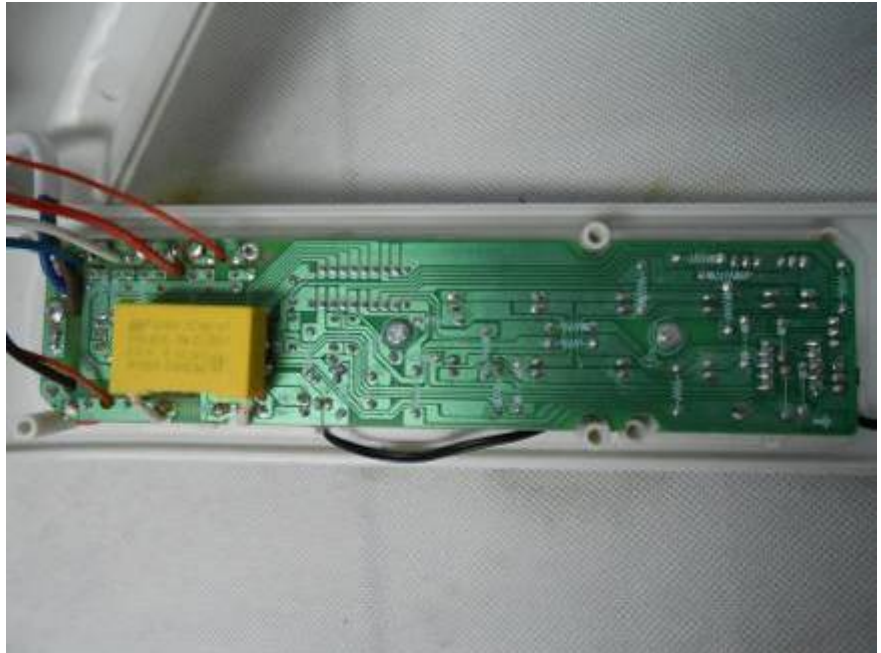



## Attachment 4

Details of: TX-1611R, PCB

---

View:

- general
- front
- rear
- right
- left
- top
- bottom
- internal



Details of: Alternative fan guard for TX-1608, TX-1608A, TX-1608B, TX-1608V, TX-1609, TX-1611, TX-1608BR, TX-1608VR, TX-1610R and TX-1611R

---

View:

- general
- front
- rear
- right
- left
- top
- bottom
- internal



## Attachment 4

Details of: Alternative fan guard for TX-1608, TX-1608A, TX-1608B, TX-1608V, TX-1609, TX-1611, TX-1608BR, TX-1608VR, TX-1610R and TX-1611R

View:

- general
- front
- rear
- right
- left
- top
- bottom
- internal



Details of: TX-1808A

View:

- general
- front
- rear
- right
- left
- top
- bottom
- internal



## Attachment 4

Details of: TX-1808A

---

View:

- general
- front
- rear
- right
- left
- top
- bottom
- internal



Details of: TX-1808A

---

View:

- general
- front
- rear
- right
- left
- top
- bottom
- internal



## Attachment 4

Details of: TX-1808A

---

View:

- general
- front
- rear
- right
- left
- top
- bottom
- internal



Details of: TX-1811

---

View:

- general
- front
- rear
- right
- left
- top
- bottom
- internal



## Attachment 4

Details of: TX-1811

---

View:

- general
- front
- rear
- right
- left
- top
- bottom
- internal



Details of: TX-1811

---

View:

- general
- front
- rear
- right
- left
- top
- bottom
- internal



## Attachment 4

Details of: TX-1811

---

View:

- general
- front
- rear
- right
- left
- top
- bottom
- internal

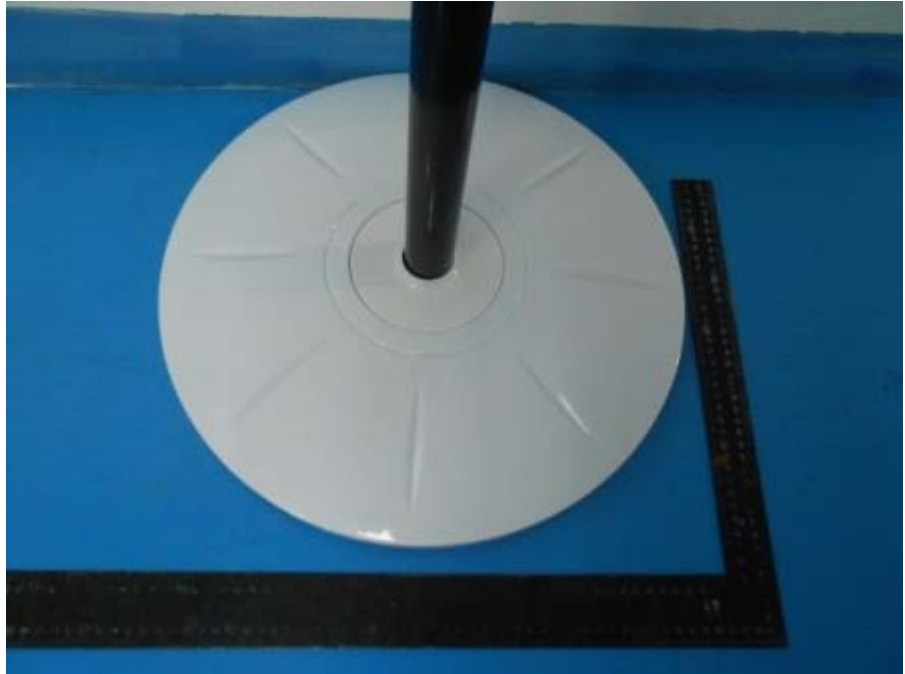

Details of: TX-1811, control panel

---

View:

- general
- front
- rear
- right
- left
- top
- bottom
- internal



## Attachment 4

Details of: TX-1811

View:

- general
- front
- rear
- right
- left
- top
- bottom
- internal



Details of: Motor, M-1808

View:

- general
- front
- rear
- right
- left
- top
- bottom
- internal



**Attachment 4**

Details of: Alternative fan guard for TX-1808A and TX-1811

View:

- general
- front
- rear
- right
- left
- top
- bottom
- internal

A photograph of a white electric fan with a mesh guard, standing on a blue surface. The fan has a circular base and a vertical stand. The mesh guard is a fine, white grid. The fan is positioned in the center of the frame.

Details of: Alternative fan guard for TX-1808A and TX-1811

View:

- general
- front
- rear
- right
- left
- top
- bottom
- internal

A close-up photograph of the white mesh fan guard. The mesh is a fine, white grid. The fan's blades are visible through the mesh. The background is a plain, light-colored wall.



## Attachment 5

### Circuit diagram

Details of: Connecting diagram for TX-1208

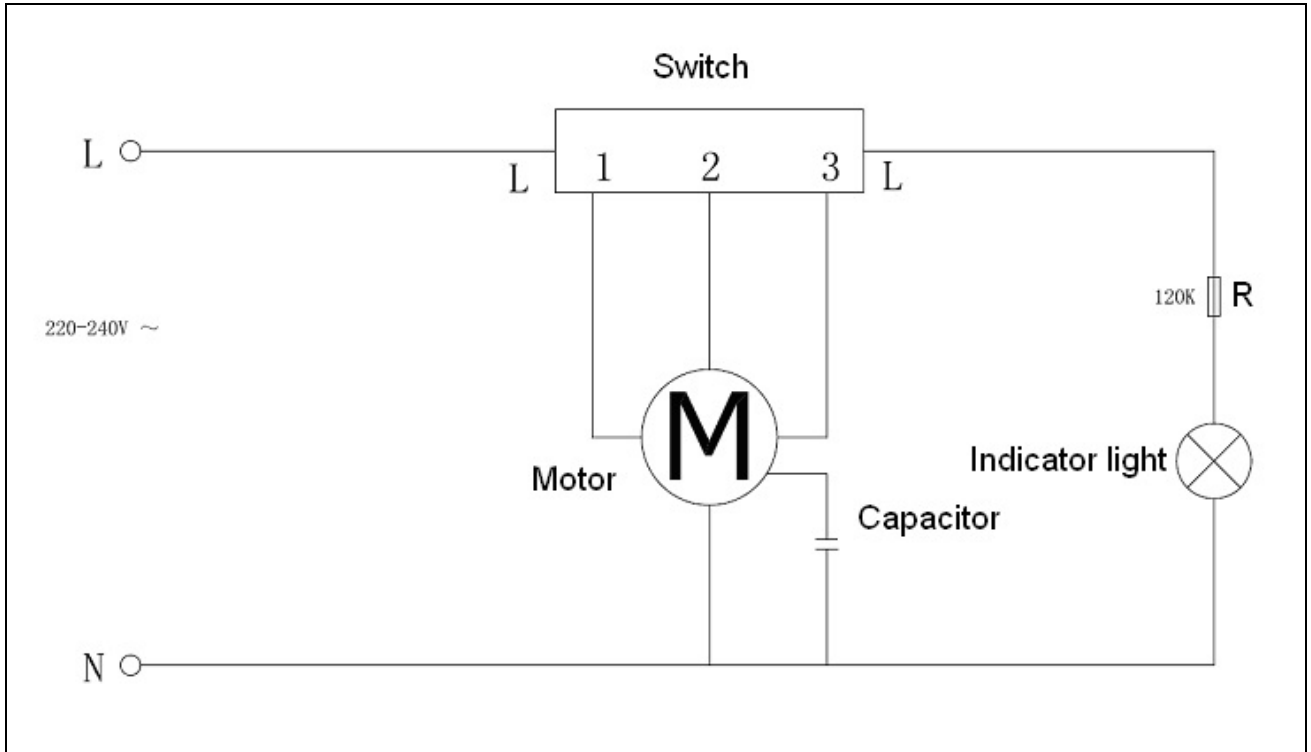

Details of: Connecting diagram for TX-1208A

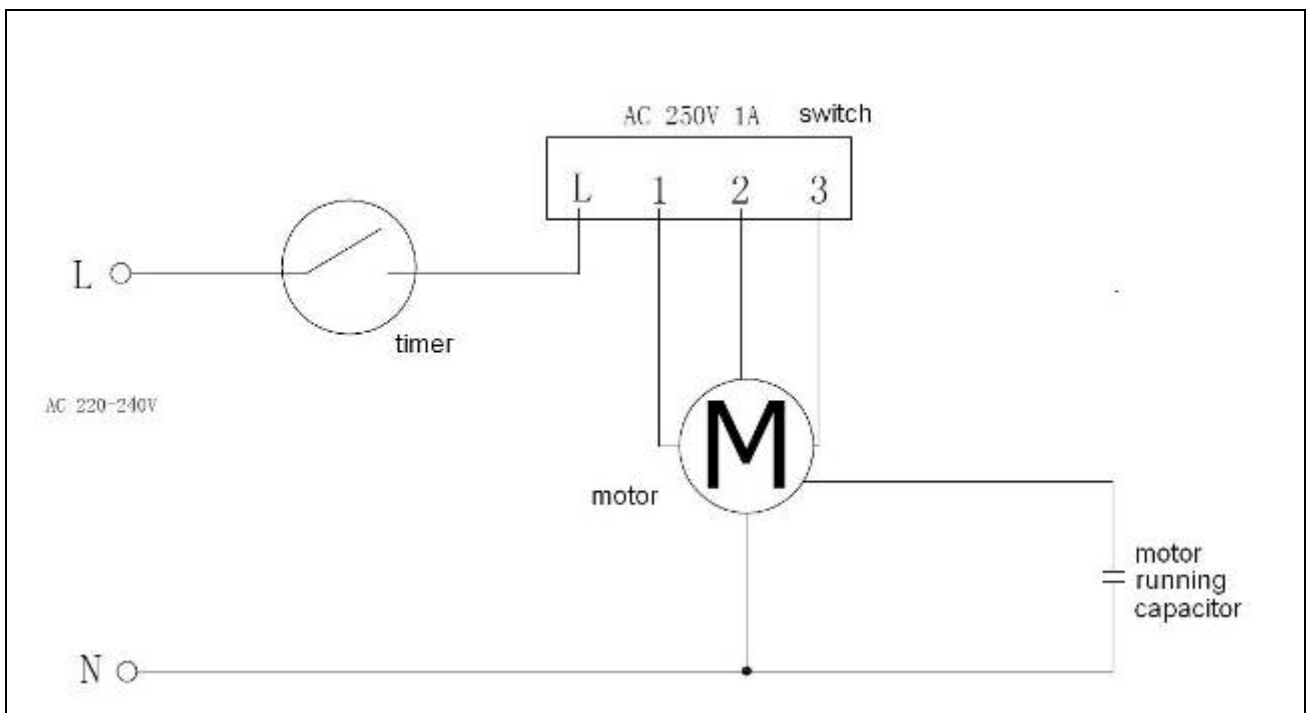

## Attachment 5

Details of: Connecting diagram for TX-1208B

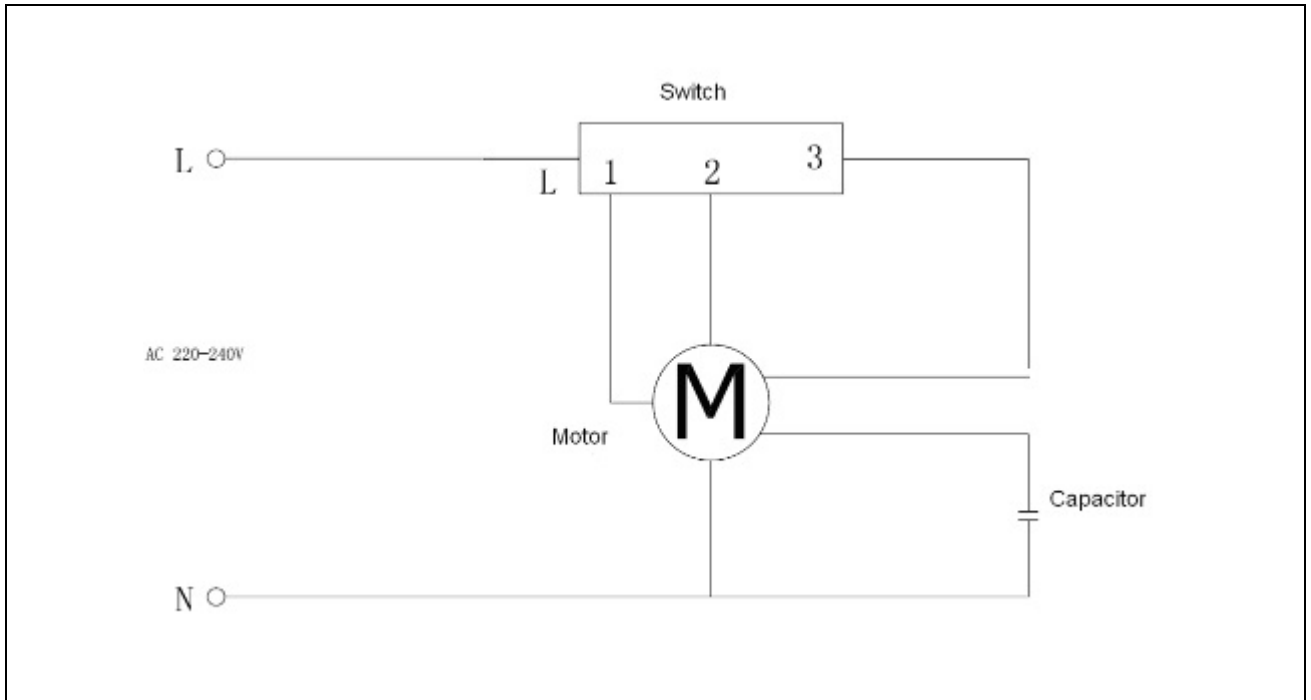

Details of: Connecting diagram for TX-1608A

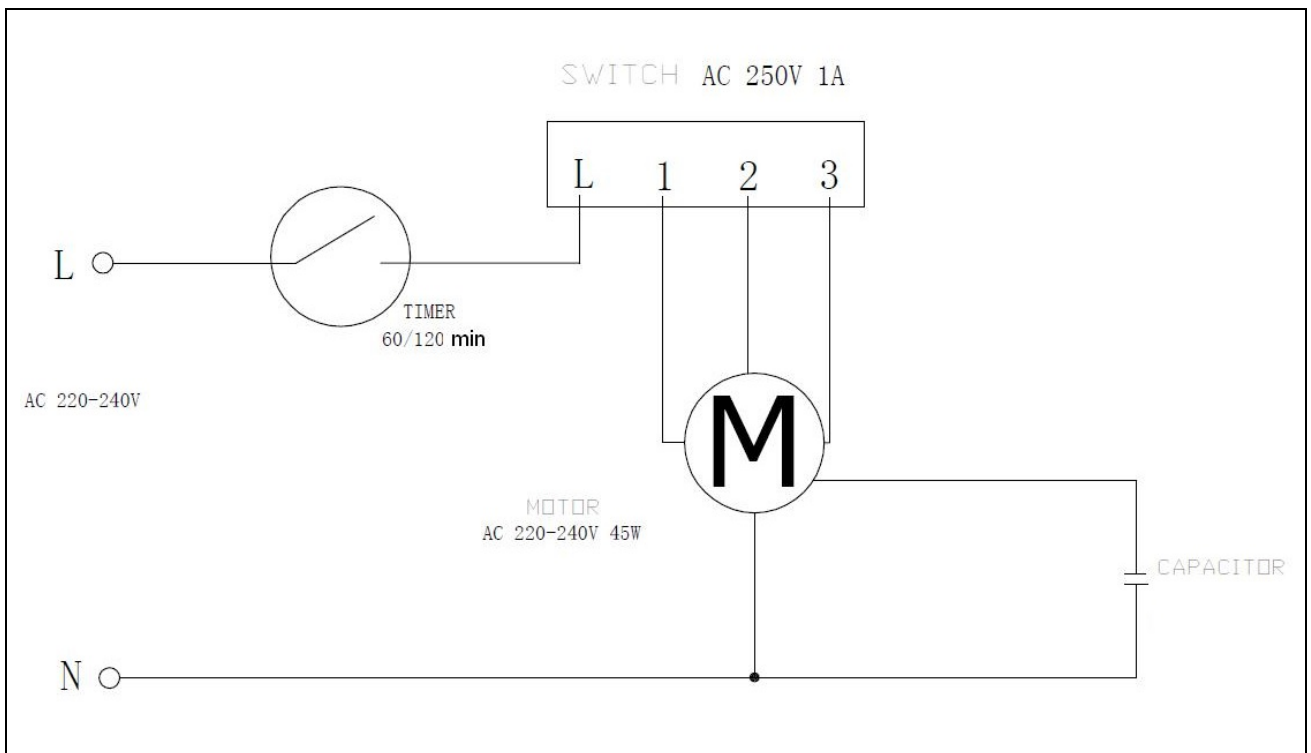

## Attachment 5

Details of: Connecting diagram for TX-1608BR

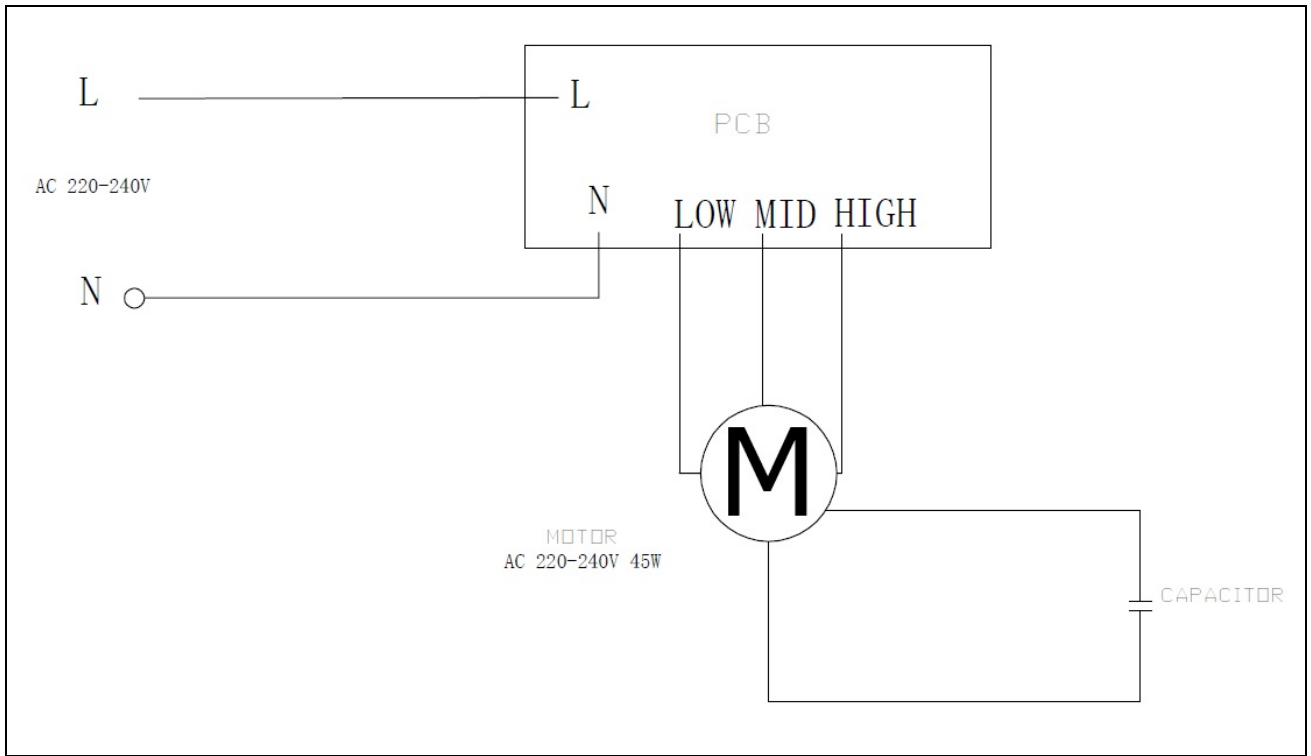

Details of: Connecting diagram for TX-1610R and TX-1611R

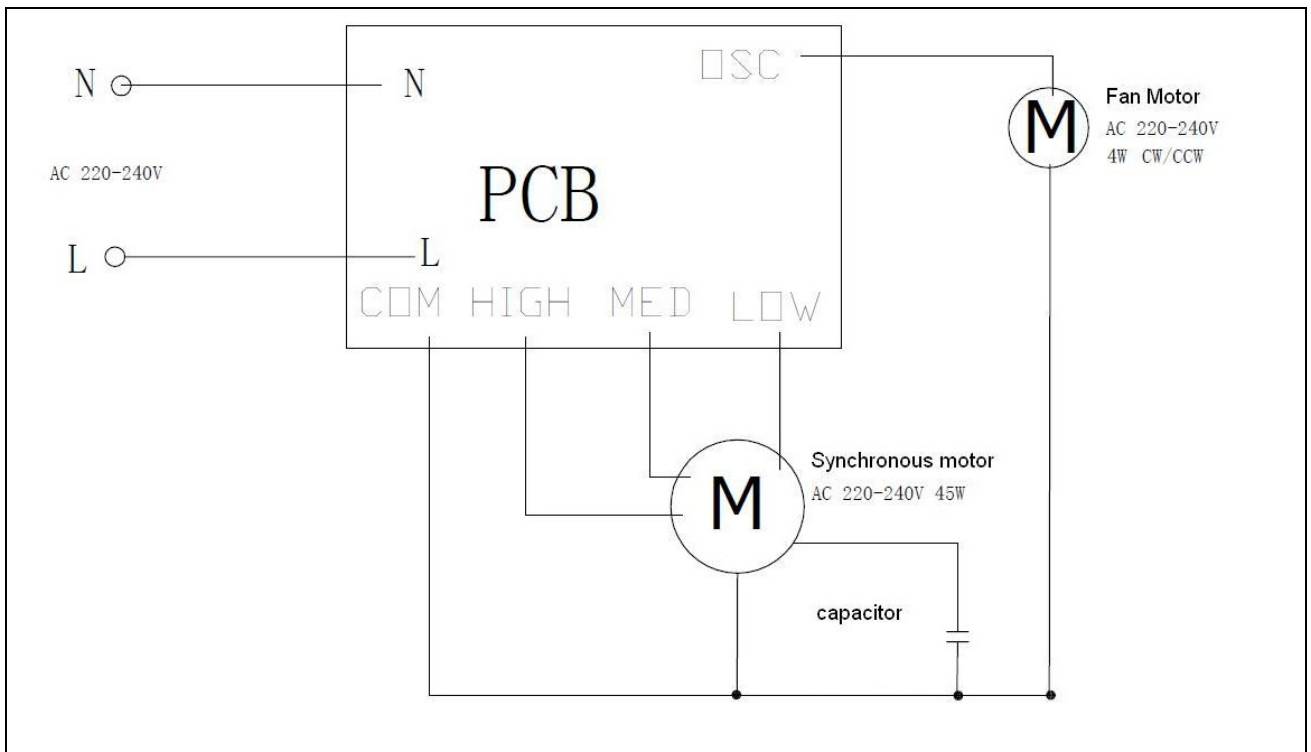

## Attachment 5

Details of: Connecting diagram for TX-1608VR

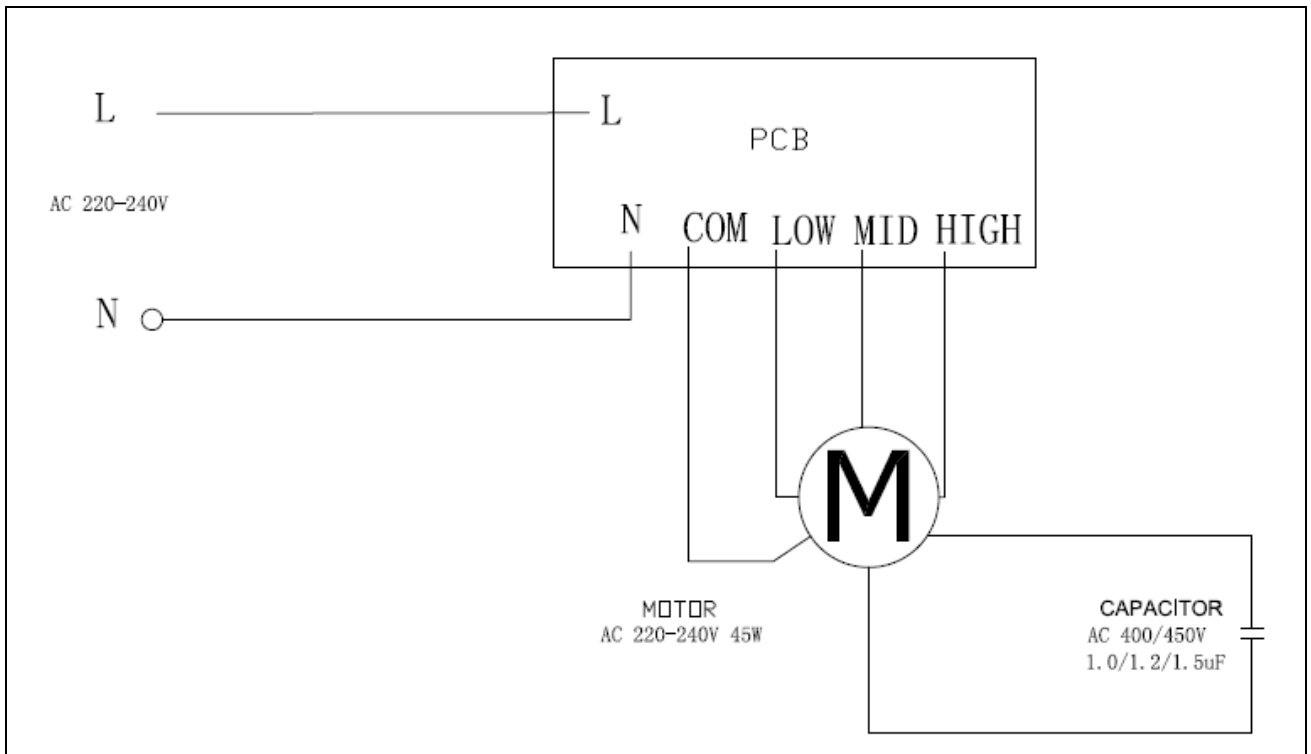

Details of: Control PCB, TX-1608BR

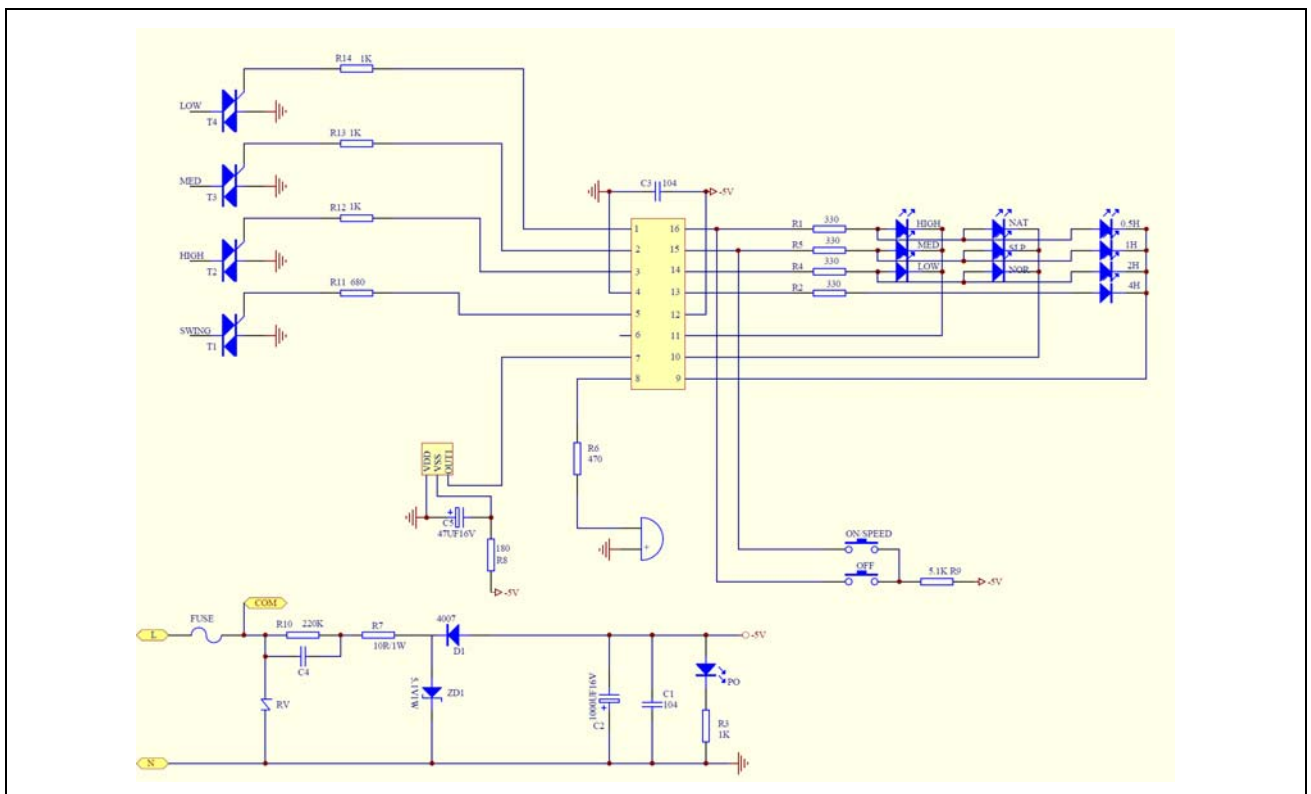

Attachment 5

Details of: Control PCB, TX-1610R

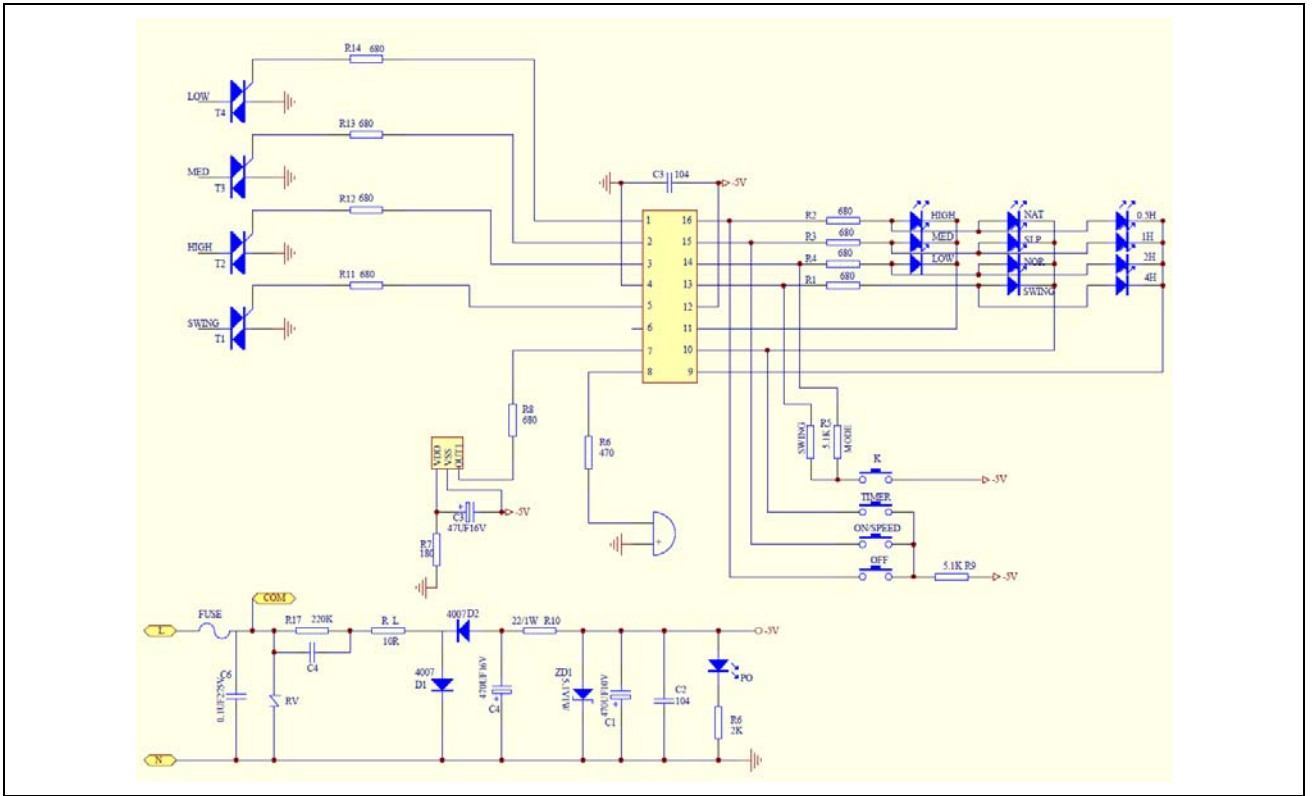

Details of: Control PCB, TX-1611R

