

1	2031B-3-1	handle	ABS
2	2031B-3-3	button	ABS
3	2031B-3-2	thread	ABS
4		inner tube	ABS
5		spring	S/S
6		ball	POM
7	2031B-9-4	base plate	ABS
8	2031B-9-5	water manifold	ABS
9	2031B-9-6	division plate	ABS
10	2031B-9-4	bubble plate	ABS
11	2031B-9-8	faceplate	ABS
12	2031B-9-9	nozzle	TPE
13		hexagon washer	POM
14		screw	S/S
15	2031B-9-10	small cover	ABS

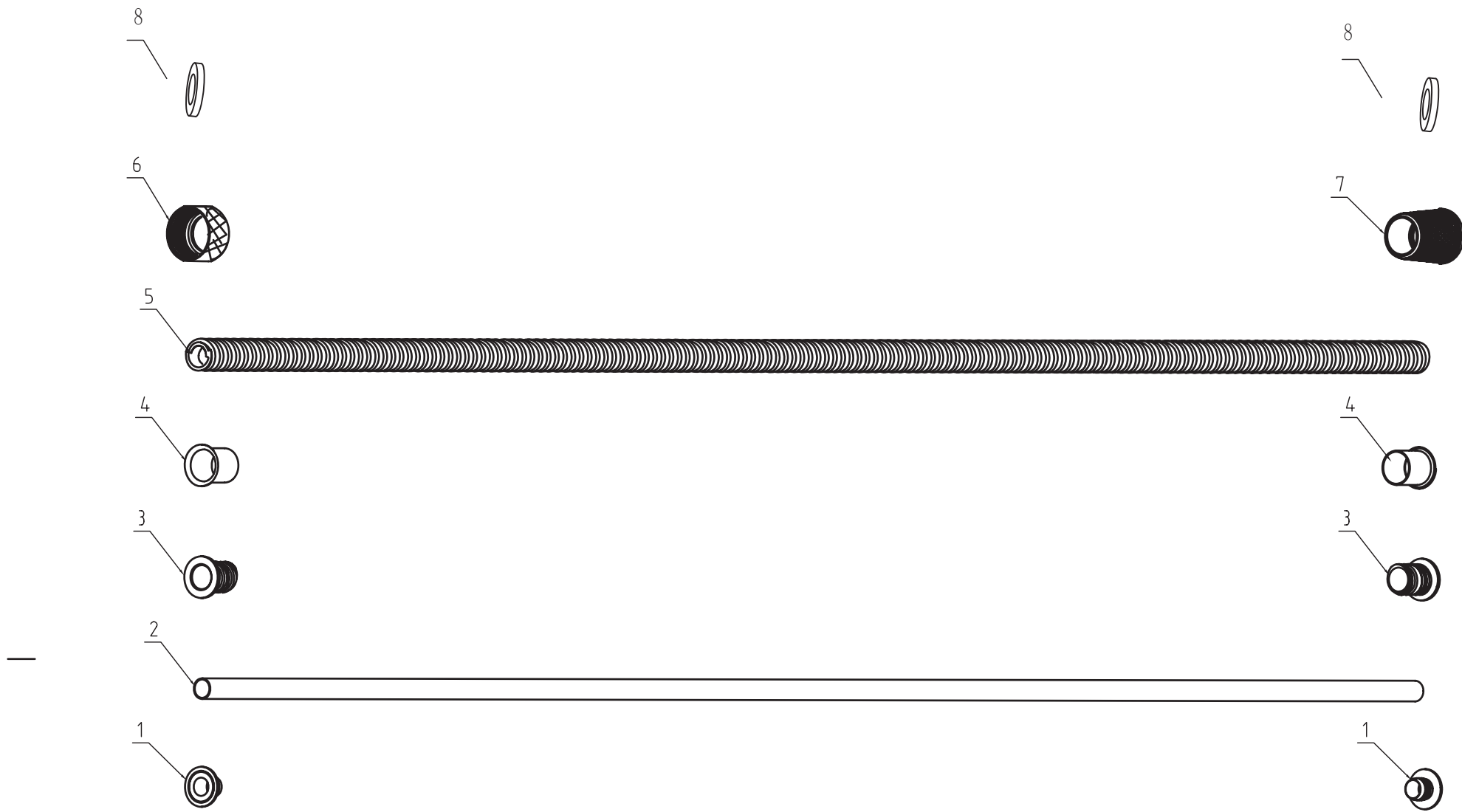

Part	item	name	material
1	S5-1	core	POM
2	S5-2	inner tube	PVC
3	S5-3	sleeve	PA66
4	S5-4	sleeve	S/S
5	S5-5	outer tube	S/S
6	S5-6	hexagen nut	brass
7	S5-7	cone nut	brass
8		o-ring	silicone

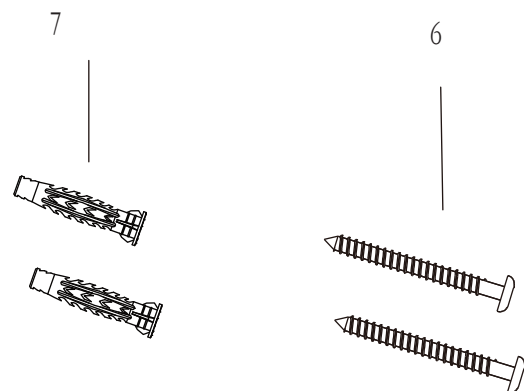
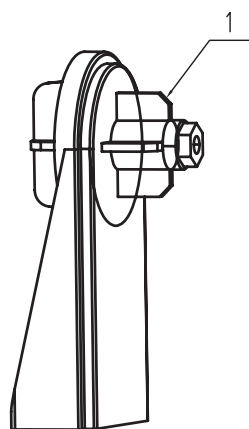
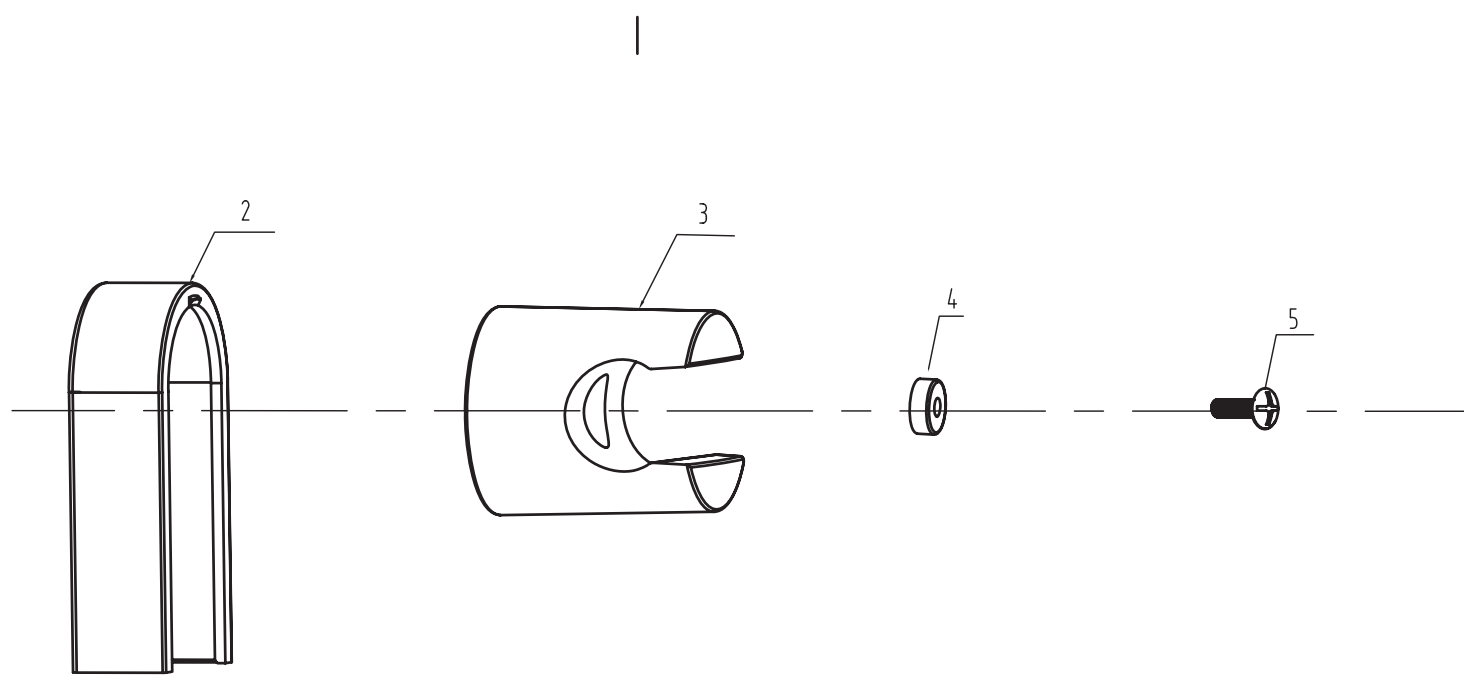

Part	item	name	material
1	F92-3-3	body	ABS
2	F92-3-2	cover	ABS
3	F92-3-1	holder	ABS
4	2064D-9-7	washer	POM
5		screw	S/S
6	$\phi 4 \times 50 \text{mm}$	screw	S/S
7	$\phi 6 \times 40 \text{mm}$	plug	pp