

Component Data Form: NFH-045C						
Layer No.	Object / Part No.	Manufacturer / Trademark	Type / Model	Technical data	Standard	Mark(s) of conformity
1.1	Plug	Ningbo Hongyi Electronics Technology Co.,Ltd.	GEP-003	16A 250V~, 2P+E,IP44	DIN VDE 0620-1	VDE 40007870
1.2	Cable	Ningbo Qianghong Electronics Co., Ltd.	H05VV-F	3G1.0/1.5mm ²	VDE 40014284	
		Ningbo HongYi Electronics Technology Co., Ltd.			VDE 40015878	
		Ningbo HongYi Electronics Technology Co., Ltd.			KEMA	
		CiXi HongYi Electronics Co., Ltd.			KEMA	
		NingBo HongYi Electronics Technology Co., Ltd.	H05RR-F	3G1.0/1.5mm ²	KEMA	
			H05RN-F	3G1.0mm ²	KEMA	
			H07RN-F	3G1.5mm ²	KEMA	
			H05RR-F	3G1.0/1.5mm ²		
			H05RN-F	3G1.0mm ²	VDE 40026367	
			H07RN-F	3G1.5mm ²		
		GuangDong HuaSheng Electrical Appliances Co., Ltd.	H05RR-F	3G1.0/1.5mm ²		
			H05RN-F	3G1.0mm ²	VDE 40030537	
H07RN-F	3G1.5mm ²					
2	Steel Shelf	Fairtown Screws Manufactory	/	A3		
3	Brake	RELIANCE INDUSTRIES LIMITED	H030SG	PP		
4	Centric circumgyrate ass'y	Ningbo HongYi Electronics Technology Co., Ltd.	/	/		
5	Cable Reel	RELIANCE INDUSTRIES LIMITED	H030SG	PP		
6	Central Stopple	RELIANCE INDUSTRIES LIMITED	H030SG	PP		
7	Inside-sheath	Ningbo HongYi Electronics Technology Co., Ltd.	H030SG	PP		
8	Socket body assy	Ningbo HongYi Electronics Technology Co., Ltd.	NFH-010A	16A 250V~, 2P+E,IP44		
9	Cable Clip	PINGDINGSHAN SHENMA ENGINEERING PLASTICS Co.,LTD.	EPR27	PA66		
10	Reel Handle	Ningbo HongYi Electronics Technology Co., Ltd.	/	PVC		
11	Handle	LG CHEMICAL LTD	HI-121H	ABS		UL:67171
12	Waterproof loop	CIXI SHIHENG RUI PLASTIC Products factory	/	Rubber		

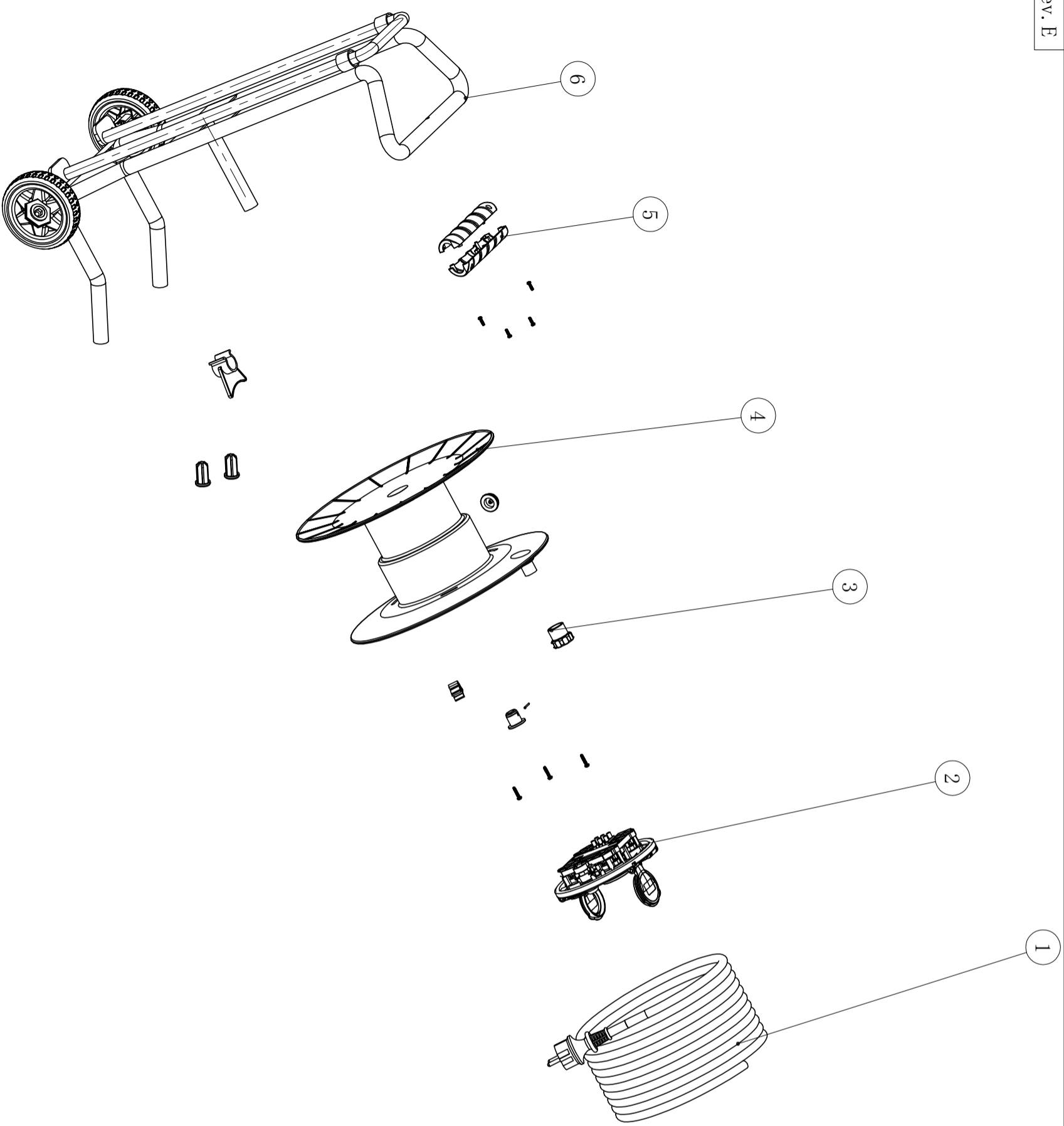

单位: mm
为检查尺寸

基本尺寸 (mm)	公差	基本尺寸 (mm)	公差	基本尺寸 (mm)	公差
>0-5	0.10	>30-40	0.28	>120-150	0.62
>5-10	0.12	>40-50	0.30	>150-200	0.80
>10-13	0.14	>50-60	0.32	>200-250	0.98
>13-16	0.16	>60-70	0.34	>250-300	1.16
>16-19	0.18	>70-80	0.36	>300-400	1.50
>19-22	0.20	>80-90	0.40	>400-500	1.70
>22-25	0.22	>90-100	0.46		
>25-30	0.24	>100-120	0.52		

备注: 此公差值为基本尺寸允许的总公差范围。材料需要满足欧盟RoHS, REACH, PAHS指令环保限制物质要求。

No	Label	Qt'y	Model No./Material	Remark
6	Steel Shelf Assy	1	N/A	
5	Handle	2	PP	
4	Cable Reel	1	PP	
3	Handle	1	ABS	
2	Socket body ass'y	1	N/A	
1	Cable Assy	1	N/A	

版本 REV.	A	Initial release	未注公差: TOLERANCE:	见公差表	批准: APPROVAL:	日期: DATE:	审核: CHECKING:	日期: DATE:	校对: CORRECT:	日期: DATE:	绘图: DRAWER:	日期: DATE:
出图日期 DRAWING DATE	02/07/2018	Jiawei Wang	材料名称: MATERIAL:	N/A							Jiawei Wang	02/07/2018
零件名称 PART NAME	Exploded Drawing	客户型号: CUSTOMER NO.:	物料编号: MATERIAL PART NO.:	CC076HA-000000-000	物料名称: MATERIAL:	日期: DATE:	日期: DATE:	日期: DATE:	日期: DATE:	日期: DATE:		
		制图 DRAWING BY	客户型号: CUSTOMER NO.:	/	物料名称: MATERIAL:	日期: DATE:	日期: DATE:	日期: DATE:	日期: DATE:	日期: DATE:		
		描述 DESCRIPTION	客户型号: CUSTOMER NO.:		物料名称: MATERIAL:	日期: DATE:	日期: DATE:	日期: DATE:	日期: DATE:	日期: DATE:		
		图纸编号: DRAWING NO.:	客户型号: CUSTOMER NO.:	00NFH053-S01-HY	物料名称: MATERIAL:	日期: DATE:	日期: DATE:	日期: DATE:	日期: DATE:	日期: DATE:		

不得测量图纸尺寸
NOT SCALE DRAWING

宁波宏一电子科技有限公司
NINGBO HONGYI ELECTRONICS TECHNOLOGY CO., LTD.