

GLOBE/GLOBE AIRTIGHT

Componenti Struttura Esterna / External structure components / Bauteile Aussenkorpus / Composants structure externe / Componentes estructura externa

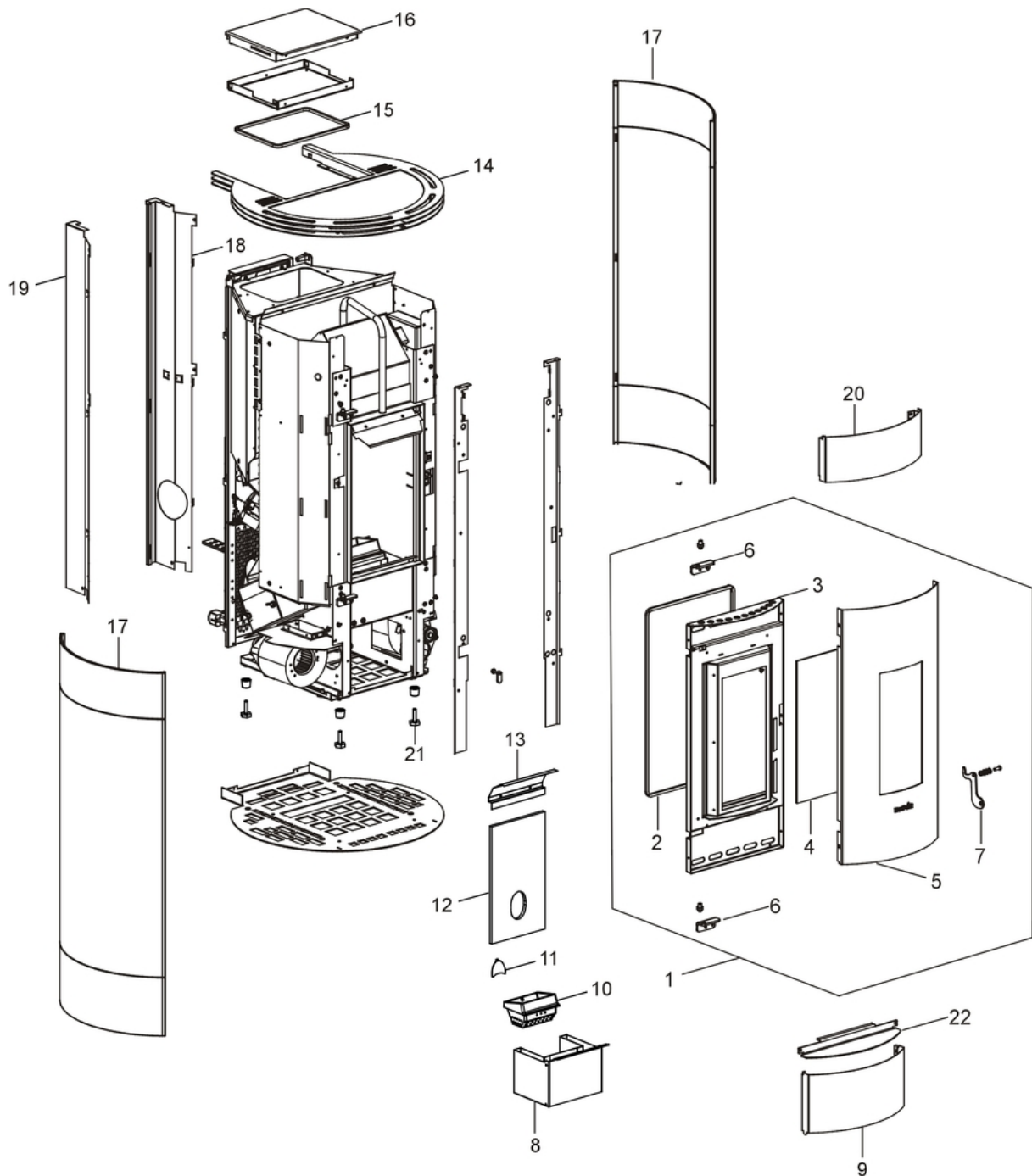

N°	Codice/Code	Descrizioni / Description / Beschreibung / Description / Descripción	Prezzo (€)
1	4D245GP15003	Porta fuoco completa / Complete door / Komplette Tür / Porte complète / Puerta completa	256.00
2	4D18013021A	Guarnizione treccia nera D.10 - 5 M / Black twist gasket D.10 - 5 M / Dichtung D.10 - 5 M / Joint tresse noire D.10 - 5 M / Junta D.10 - 5 M	26.00
2	4D18013021B	Guarnizione treccia nera D.10 - 50 M / Black twist gasket D.10 - 50 M / Dichtung D.10 - 50 M / Joint tresse noire D.10 - 50 M / Junta D.10 - 50 M	135.00
3	4D24016070461	Telaio porta 675x310 / Door frame 675x310 / Türrahmen 675x310 / Cadre porte 675x310 / Marco puerta 675x310	138.00
4	4D170140010	Vetroceramico 385x175x4 mm / Glass 385x175x4 mm / Glasskeramikscheibe 385x175x4 mm / Vitrocéramique 385x175x4 mm / Cristal cerámico 385x175x4 mm	72.00

4	4D18013008A	Guarnizione 10x3 (5m) / Gasket 10x3 (5m) / Dichtung 10x3 (5m) / Joint 10x3 (5m) / Junta 10x3 (5m)	26.00
4	4D18013008C	Guarnizione 10x3 (100m) / Gasket 10x3 (100m) / Dichtung 10x3 (100m) / Joint 10x3 (100m) / Junta 10x3 (100m)	260.00
4	4D170157040	Vetroceramico 379X193X4 / Ceramic glass 379X193X4 / Glaskeramikscheibe 379X193X4 / Vitrec�ramique 379x193x4 mm / Cristal cer�mico 379x193x4 mm	85.00
5	4D24014954361	Porta esterna / External door / Au�sere T�r / Porte externe / Puerta externa	98.00
6	4D2401303720	Supporto porta nero / Black door support / Schwarzes T�rhalteb�gel / Support porte noir / Soporte puerta negro	21.00
6	4D2401303720	Supporto porta nero / Black door support / Schwarzes T�rhalteb�gel / Support porte noir / Soporte puerta negro	21.00
7	4D24014066161	Maniglia / Handle / Griff / Poign�e / Tirador	22.00
7	4D24015841361	Kit decompressione camera di combustione / Pressure relief kit / Bausatz �berdruckablauf Brennkammer / Kit decompression chambre de combustion / Kit decompressi�n c�mara de combusti�n	32.00
8	4D24014015461	Cassetto cenere / Ash drawer / Aschenkasten / Tiroir � cendres / Caj�n ceniza	65.00
9	4D24014951317	Pannello frontale inferiore Moka / Moka lower frontal panel / Vorderes unteres Paneel Moka / Panneau ant�rieur inf�rieur Moka / Panel frontal inferior Moka	64.00
9	4D24014951396	Pannello frontale inferiore White / White lower frontal panel / Vorderes unteres Paneel White / Panneau ant�rieur inf�rieur White / Panel frontal inferior White	64.00
9	4D24014951340	Pannello frontale inferiore Antracite / Charcoal lower frontal panel / Vorderes unteres Paneel Anthrazit / Panneau ant�rieur inf�rieur Antracite / Panel frontal inferior Antracita	64.00
10	413008003	Braciere completo in ghisa / Cast iron complete grate / Kompletter Brennertopf aus Gusseisen / Brasero complet en fonte / Brasero completo de arrabio	50.00
10	4D13016602061	Braciere / Grate / Brennschale / Brasero / Brasero	40.00
11	4D2401303101	Deflettore pellet / Pellet deflector / Pellet Leitblech / Deflecteur pellet / Deflector pellet	25.00
12	4D115140020	Schiena in Calorite / Calorite back / R�ckwand aus Calorite / Fond en Calorite / Parte trasera de Calorite	40.00
13	4D242140043	Supporto Vermiculite / Vermiculite support / Vermiculite Halterung / Support Vermiculite / Soporte Vermiculite	25.00
14	4D24014959461	Top nero / Black top / Abdeckplatte Schwarz / Dessus noir / Top negro	171.00
15	4D18013016	Guarnizione 155X190 mm / Gasket 155X190 mm / Dichtung 155x190 mm / Joint 155X190 mm / Junta 155X190 mm	22.00
16	4D24014020361	Coperchio serbatoio pellet / Pellet hopper cover / Deckel Pelletbeh�lter / Couvercle r�servoir pellet / Tapadera dep�sito	38.00
17	4D24014962317	Fianco DX-SX Moka / R.-L. Moka side / RE.-LI. Aussenseite Moka / C�t� D-G Moka / Lateral DCHO-IZDO Moka	82.00
17	4D24014962317	Fianco DX-SX Moka / R.-L. Moka side / RE.-LI. Aussenseite Moka / C�t� D-G Moka / Lateral DCHO-IZDO Moka	82.00
17	4D24014962396	Fianco DX-SX White / R.-L. White side / RE.-LI. Aussenseite White / C�t� D-G White / Lateral DCHO-IZDO White	82.00
17	4D24014962396	Fianco DX-SX White / R.-L. White side / RE.-LI. Aussenseite White / C�t� D-G White / Lateral DCHO-IZDO White	82.00
17	4D24014962340	Fianco DX-SX Antracite / R.-L. Anthracite side / RE.-LI. Aussenseite Anthrazit / C�t� D-G Anthracite / Lateral DCHO-IZDO Antracita	94.00
17	4D24014962340	Fianco DX-SX Antracite / R.-L. Anthracite side / RE.-LI. Aussenseite Anthrazit / C�t� D-G Anthracite / Lateral DCHO-IZDO Antracita	94.00
18	4D24014057363	Montante posteriore DX / Rear R. vertical rod / Hintere R. Montageleiste / Montant post�rieur D. / Montante posterior DCHO	54.00
19	4D24014058363	Montante posteriore SX / Rear L. vertical rod / Hintere L. Montageleiste / Montant post�rieur G. / Montante posterior IZDO	66.00
20	4D24014953361	Pannello frontale superiore nero / Upper black frontal panel / Vorderes oberes Paneel schwarz / Panneau ant�rieur sup�rieur noir / Panel frontal superior negro	67.00
21	4D12013006	Piedini di appoggio (4 pz.) / Support feet (4 pcs.) / Einstellf��e (4 Stck.) / V�rins (4 pcs) / Pies de apoyo (4 pzs)	23.00
22	4D24014952363	Sottoporta nero / Door protection / Schutz unter der T�r / Protection sous porte / Resguardo abajo puerta	50.00

GLOBE/GLOBE AIRTIGHT

Componenti interni meccanici ed elettronici / Electronic and mechanic internal parts / Interne mechanische und elektronische Bauteile / Composants internes mécaniques et électroniques / Componentes internos electrónicos y mecánicos

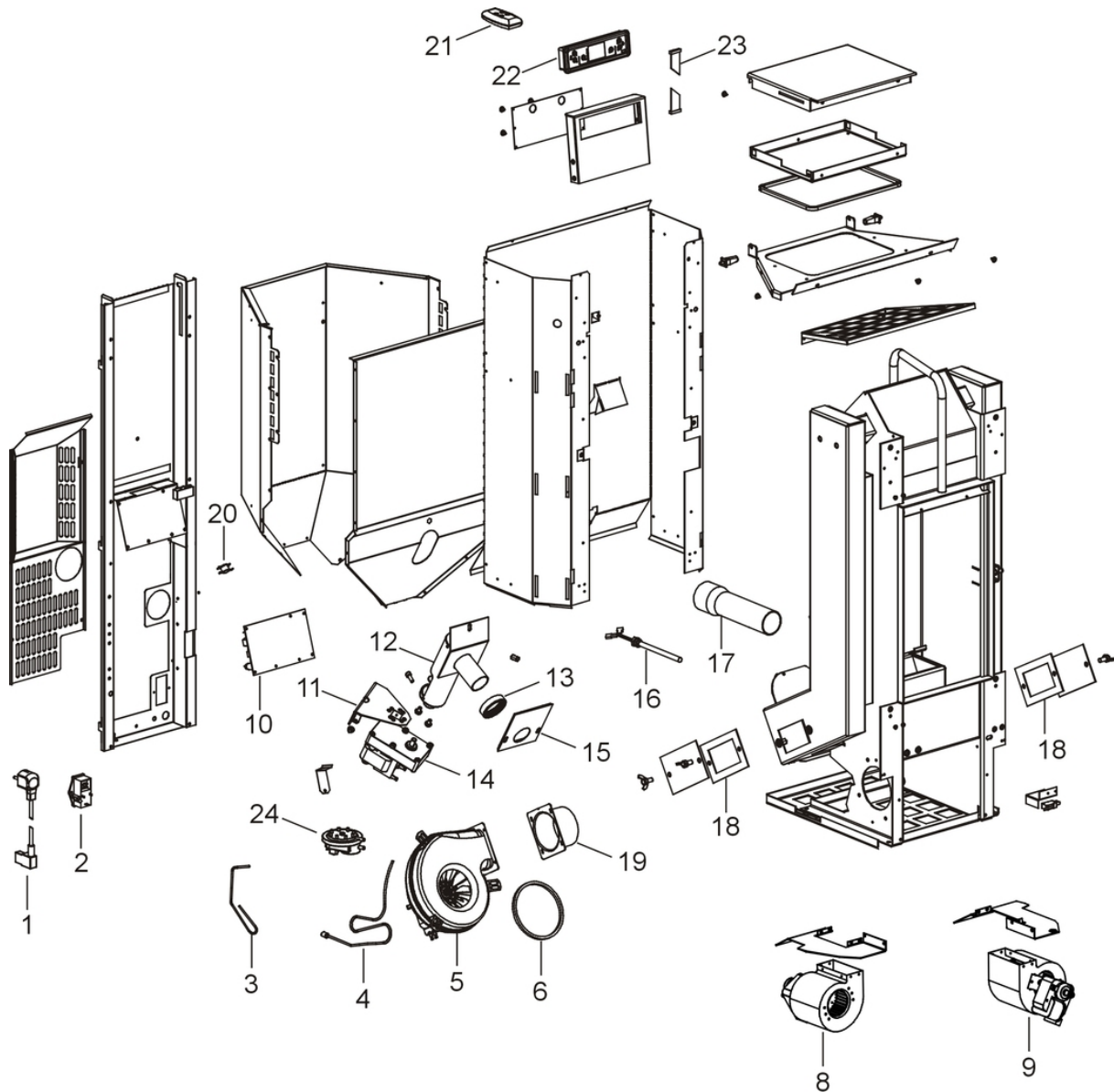

N°	Codice/Code	Descrizioni / Description / Beschreibung / Description / Descripción	Prezzo (€)
1	4D14513041	Cavo alimentazione / Power source cable / Zündungskabel / Câble alimentation / Cable alimentación	24.00
2	4160193	Pulsante accensione / On/Off button / Zündungstaste / Touche d'allumage / Botón encendido	28.00
3	4D145150090	Sonda fumi / Smoke sensor / Rauchsonde / Sonde fumées / Sonda humos	28.00
3	4D145150060	Sonda fumi / Smoke sensor / Rauchsonde / Sonde fumées / Sonda humos	30.00
4	4D145150110	Sonda ambiente / Room temperature sensor / Raumtemperaturfühler / Sonde température ambiance / Sonda ambiente	23.00
5	4D145140150	Ventilatore fumi stagno / Tin smoke fan / Hermetisch Dichtrauchgebläse / Ventilateur fumées étanche / Ventilador humos hermético	121.00
5	41801600800	Guarnizione ventilatore fumi / Smoke exhaust fan gasket / Dichtung Rauchabsauggebläse / Joint Ventilateur aspiration fumées / Junta ventilador aspiración humos	22.00
5	41451209300	Encoder per ventilatore fumi marchi LN2/SIT / Encoder for LN2/SIT smoke fan / Encoder für LN2/SIT Rauchgasgebläse / Encoder pour ventilateur des fumées marques LN2/SIT / Encoder para ventilador humos marcas LN2/SIT	21.00

6	4D18013024	Guarnizione / Gasket / Dichtung / Joint / Junta	24.00
8	4D14513054	Ventilatore aria / Air fan / Luftgebläse / Ventilateur air / Ventilador aire	101.00
8	4D145198010	Ventilatore aria / Air fan / Luftgebläse / Ventilateur air / Ventilador aire	71.00
9	4D14513054	Ventilatore aria / Air fan / Luftgebläse / Ventilateur air / Ventilador aire	101.00
9	4D145198020	Ventilatore aria / Air fan / Luftgebläse / Ventilateur air / Ventilador aire	71.00
10	4D14513064	Scheda madre / Motherboard / Hauptplatine / Carte mère / Tarjeta madre	159.00
10	4D14513064B	Scheda madre / Motherboard / Hauptplatine / Carte mère / Tarjeta madre	135.00
10	4D145157020A	Scheda madre N10064K / Motherboard N10064K / Hauptplatine N10064K / Carte mère N10064K / Tarjeta madre N10064K	100.00
11	4D2401302613	Supporto coclea / Feed screw support / Schnecke Halterung / Support de la vis-sans-fin / Soporte cóclea	30.00
12	4D140160030	Coclea di caricamento pellet / Pellet feed screw / Pelletsförderschnecke / Vis sans fin pour chargement du pellet / Cóclea de carga pellet	110.00
12	4D180177070	Coclea di caricamento pellet / Pellet feed screw / Pelletsförderschnecke / Vis sans fin pour chargement du pellet / Cóclea de carga pellet	89.00
12	4D180177010	Boccola / Bushing / Buchse / Douille / Abrazadera	23.00
13	4D18013003	Guarnizione D.50 mm / Gasket D.50 mm / Dichtung D.50 mm / Joint D.50 mm / Junta D.50 mm	26.00
14	4D145159010	Motoriduttore 3,3 rpm / Reduction motor 3,3 rpm / Getriebemotor 3,3 rpm / Motorréducteur 3,3 rpm / Motorreductor 3,3 rpm	117.00
14	4D145181020	Motoriduttore 2 rpm / Reduction motor 2 rpm / Getriebemotor 2 rpm / Motorréducteur 2 rpm / Motorreductor 2 rpm	91.00
15	4D18013004	Guarnizione 100X108 mm / Gasket 100X108 mm / Dichtung 100x108 mm / Joint 100X108 mm / Junta 100X108 mm	23.00
16	4D14513002	Candeletta / Sparkplug / Zündkerze Pelletzündung / Bougie / Bujía encendido pellet	39.00
16	4D145181040	Candeletta / Sparkplug / Zündkerze / Bougie / Bujía	38.00
17	4D160140040	Tubo ingresso aria 60x2x210 mm / Air inlet pipe 60x2x210 mm / Lufteingangrohr 60x2x210 mm / Tuyau entrée air 60x2x210 mm / Tubo entrada aire D.80 L.200 mm	30.00
17	4D18013003	Guarnizione D.50 mm / Gasket D.50 mm / Dichtung D.50 mm / Joint D.50 mm / Junta D.50 mm	26.00
18	4D18013001	Guarnizione 130x80 mm / Gasket 130x80 mm / Dichtung 130x80 mm / Joint 130x80 mm / Junta 130x80 mm	24.00
18	4D18013001	Guarnizione 130x80 mm / Gasket 130x80 mm / Dichtung 130x80 mm / Joint 130x80 mm / Junta 130x80 mm	24.00
19	4D14513040	Raccordo D.80 mm / Connector D.80 mm / Anschlußrohr D.80 mm / Raccord D.80 mm / Racor D.80 mm	22.00
20	4D14513006	Termostato 60°C / Thermostat 60°C / Thermostat 60°C / Thermostat 60°C / Termostato 60°C	22.00
21	5019012	Telecomando / Remote control / Fernbedienung / Télécommande / Mando a distancia	49.00
22	4D14513032	Pannello comandi / Control panel / Bedienblende / Tableau de commande / Panel de mandos	74.00
22	4D1451303300	Pannello comandi grafico / Graphic control panel / Graphische Bedienblende / Tableau de commande / Panel de mandos gráfico	102.00
23	4D14513007	Cavo flat scheda-pannello / Flat cable motherboard-control panel / Flat Kabel Hauptplatine-Bedienblende / Câble flat carte mère-panneau commande / Cable flat tarjeta madre-panel de mandos	31.00
24	4160482	Pressostato 0,4 mbar / Pressure gauge 0,4 mbar / Druckwächter 0,4 mbar / Pressostat 0,4 mbar / Presostato 0,4 mbar	38.00
25	4D241140013	Carter posteriore / Back carter / Hinteres Blech / Protection arrière / Carter trasero	55.00