

产品型号	日期	承办人	核准人	版次	页次
KFC-817A (02)	2019. 10. 30	范晨琼		1	

版本 REV	变更号 CHANGE NO.	年月日 DATE	变更记述内容 CHANGE DESCRIPTION	登记者 BOOKER

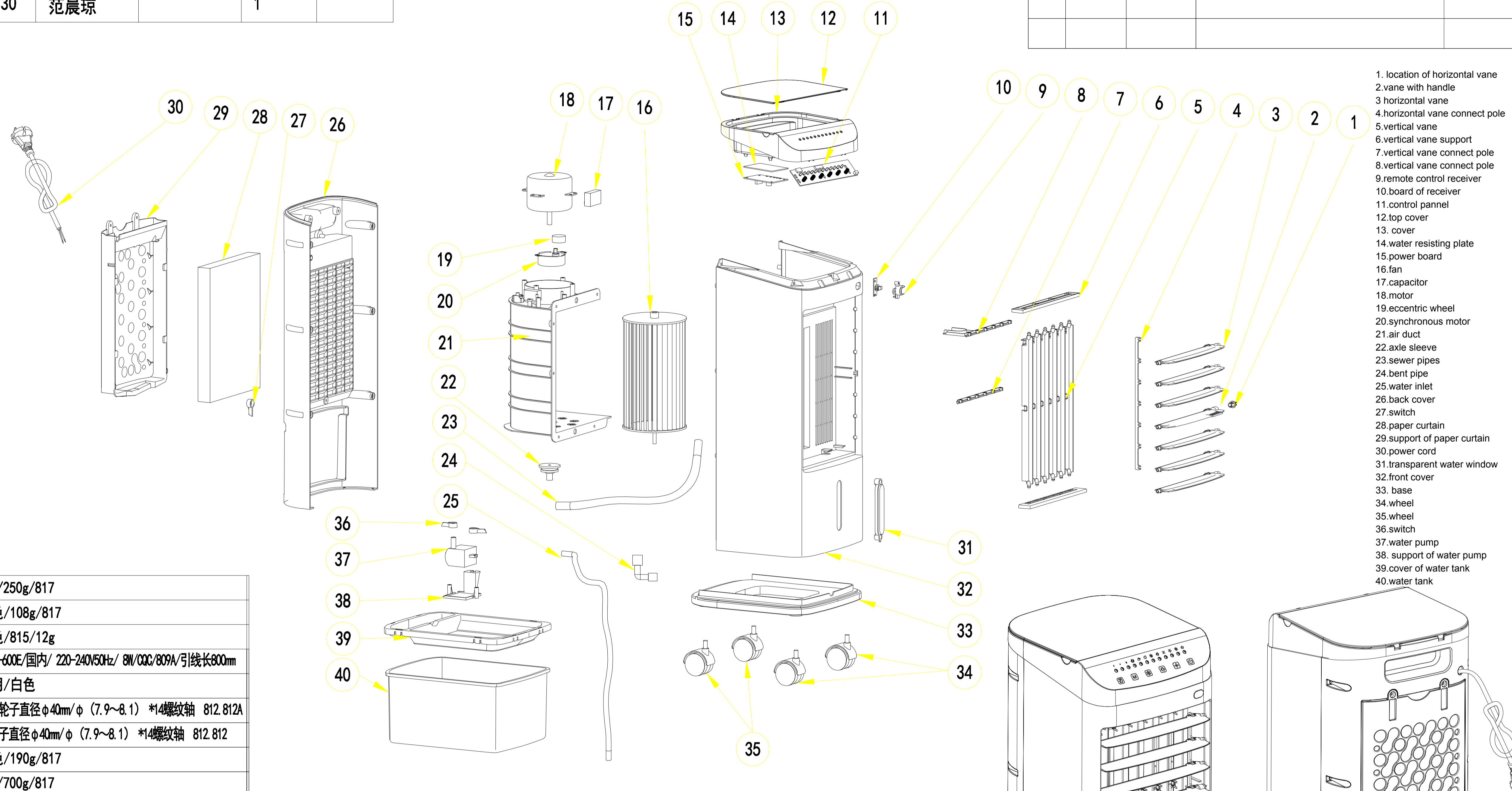

1. location of horizontal vane
- 2.vane with handle
- 3 horizontal vane
- 4.horizontal vane connect pole
- 5.vertical vane
- 6.vertical vane support
- 7.vertical vane connect pole
- 8.vertical vane connect pole
- 9.remote control receiver
- 10.board of receiver
- 11.control pannel
- 12.top cover
13. cover
- 14.water resisting plate
- 15.power board
- 16.fan
- 17.capacitor
- 18.motor
- 19.eccentric wheel
- 20.synchronous motor
- 21.air duct
- 22.axle sleeve
- 23.sewer pipes
- 24.bent pipe
- 25.water inlet
- 26.back cover
- 27.switch
- 28.paper curtain
- 29.support of paper curtain
- 30.power cord
- 31.transparent water window
- 32.front cover
33. base
- 34.wheel
- 35.wheel
- 36.switch
- 37.water pump
38. support of water pump
- 39.cover of water tank
- 40.water tank

40	水箱	1	PP/透明/250g/817
39	水箱盖	1	ABS/白色/108g/817
38	水泵支架	1	ABS/白色/815/12g
37	水泵	1	小水泵/AP-600E/国内/ 220-240V50Hz/ 8W/CQC/809A/引线长800mm
36	小旋钮	1	ABS/通用/白色
35	脚轮	1	不带刹车/轮子直径φ40mm/φ(7.9~8.1) *14螺纹轴 812.812A
34	脚轮	3	带刹车/轮子直径φ40mm/φ(7.9~8.1) *14螺纹轴 812.812
33	底板	2	ABS/白色/190g/817
32	前壳	2	PP/白色/700g/817
31	透明水窗	1	AS/透明/816/8g
30	电源线	1	国内/黑/2*0.75*1.95m/外剥7cm/L. N半脱13mm/PVC扁线
29	湿帘支架	1	ABS/白色/150g/817
28	纸帘	1	180*250*25cm草绿色
27	小旋钮	1	ABS/白色/808A/808BL/1g
26	后壳	1	PP/白色/380g/817
25	进水管	1	硅胶内径φ8mm长470mm
24	弯水管	1	内径14mm 长度80mm 丝径1mm
23	下水管	1	硅胶内径φ9.7mm长270mm
22	轴套	1	风轮厂自带
21	风道	1	ABS/黑色/230g/817
20	同步电机	1	双铣边/220V50Hz/3.5W国内/809A/ TYZ-49/TYZ-49
19	偏心轮	1	POM/通用/806
18	电机	1	YYHS-60/220V50Hz/国内/809标贴“YYHS-60C, 220V50Hz16W E级”
17	电容	1	1.2UF/500V/CQC/中文CBB6100/
16	风轮	1	增强ABS/黑色/φ115*200/轴的外露长度23.0mm/三节/817/812
序号	零件名称	数量	规格

15	电源板	1	CF/SJ-KFC/817A (02)
14	PCB隔板	1	CF/SJ-KFC/817A (02)
13	电子款顶盖	1	ABS/黑色/310g/817A (02)
12	盖板	1	ABS/黑色/130g/817A (02)
11	控制板	1	CF/SJ-KFC/817A (02)
10	接收头板	1	809A接收头板
9	遥控接收窗	1	PC/黑色/3g/817
8	横摆叶连杆	1	ABS/白色/25g/817
7	竖摆叶小连杆	1	ABS/白色/25g/817
6	竖摆叶支架	2	ABS/白色/25g/817
5	竖摆叶	6	ABS/白色/25g/817
4	横摆叶连杆	1	ABS/白色/25g/817
3	横摆叶	6	ABS/白色/25g/817
2	带柄横摆叶	1	ABS/白色/25g/817
1	带柄横摆叶定位件	1	POM/白色/813/1g
序号	零件名称	数量	规格

宁波市慈溪奥田电器有限公司 NINGBO CITY CIXI AUTIAN ELECTRIC APPLIANCES CO.,LTD.			机种 MODEL	KFC-817A (02) 冷风扇
请勿实测图面尺寸 DO NOT SCALE DRAWING			零件名称 PART NAME	爆炸图
制图 DRAWN	范晨琼	2019. 10. 30	图号 DWG NO.	CF/SJ-KFC/817A (02) -BZT-001
审核 CHECKED BY			单位 UNIT	mm
确认 APPROVED BY			比例 SCALE	/
			第一角法 1RD ANGLE'S	
			版本号 REV	1