

DH D002A Exploded View

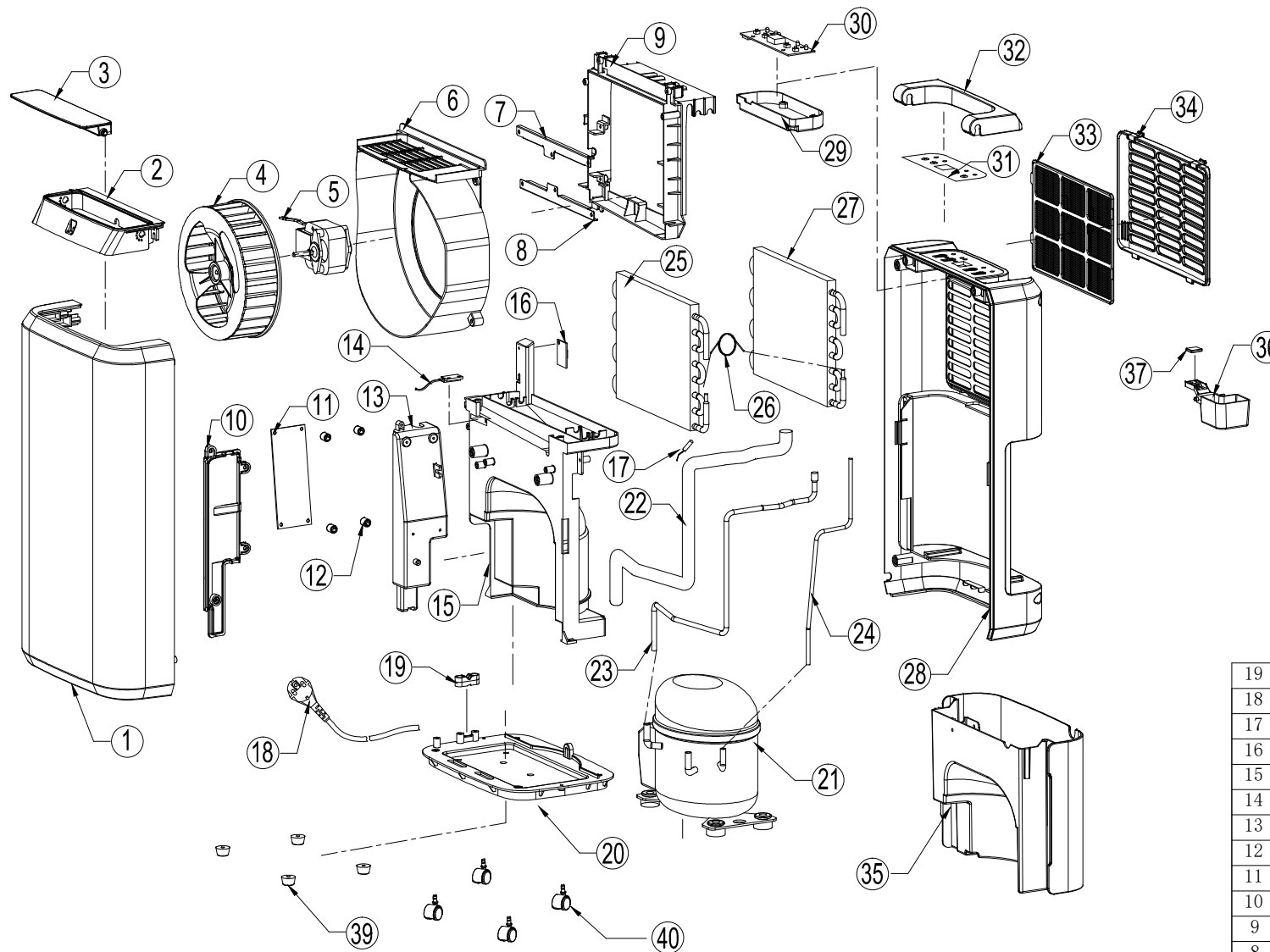

		39	Wheels
19	Wire Clamp	38	Magnet
18	Power Cord	37	Float
17	Rubber Pad	36	Water Tank
16	Humidity sensor	35	Filter Frame
15	Isolate Plate	34	Filter
14	Magnetic Switch	33	Handle
13	Power Electric Box	32	Control Mask
12	Isolation Support	31	Display PCB
11	Power PCB	30	Control Mask
10	Electric Box Cover	29	Rear Panel
9	Motor Support	28	Evaporator
8	Motor Support-B	27	Capillary Sleeve
7	Motor Support-A	26	Capillary
6	Air Volute	25	Condenser
5	Shaded pole motor	24	Discharge Pipe
4	Fan	23	Suction Pipe
3	Louver	22	Insolation Pipe
2	Air Outlet	21	Compressor
1	Front Panel	20	Base
No	Description	No	Description