

INDOOR UNIT

**No. OBB822
REVISED EDITION-D**

PARTS CATALOG

Models

MSZ-HR25VF - **E1**, **ER1**, **ET1**

MSZ-HR35VF - **E1**, **ER1**, **ET1**

MSZ-HR42VF - **E1**, **ER1**, **ET1**

MSZ-HR50VF - **E1**, **ER1**, **ET1**

MSZ-HR60VF - **E1**, **ER1**, **ET1**, **E2**

MSZ-HR71VF - **E1**, **ER1**, **ET1**, **E2**



MSZ-HR25VF



CONTENTS

1. SERVICE PARTS LIST 2
2. OPTIONAL PARTS 14

SERVICE MANUAL (OBH822)

Revision A:

• Some descriptions have been modified.

Revision B:

• MSZ-HR60/71VF- [E1], [ET1] have been added.

Revision C:

• MSZ-HR60/71VF- [ER1] have been added.

Revision D:

• MSZ-HR60/71VF- [E2] have been added.

1

SERVICE PARTS LIST

MSZ-HR25VF MSZ-HR35VF

1-1. INDOOR UNIT STRUCTURAL PARTS

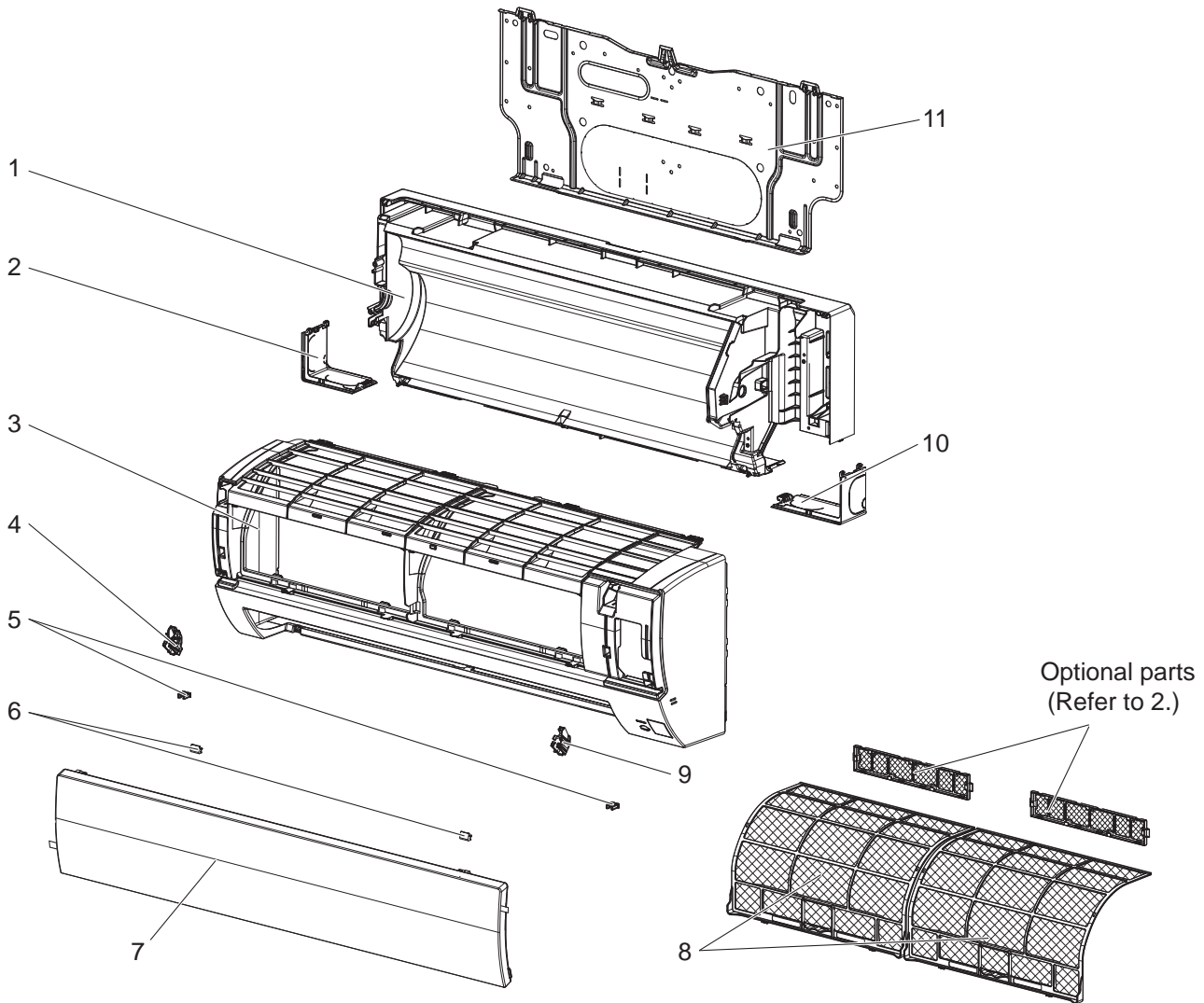

1-2. ACCESSORY AND REMOTE CONTROLLER

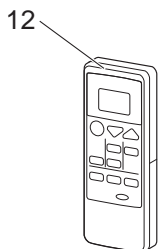

1-3. INDOOR UNIT HEAT EXCHANGER

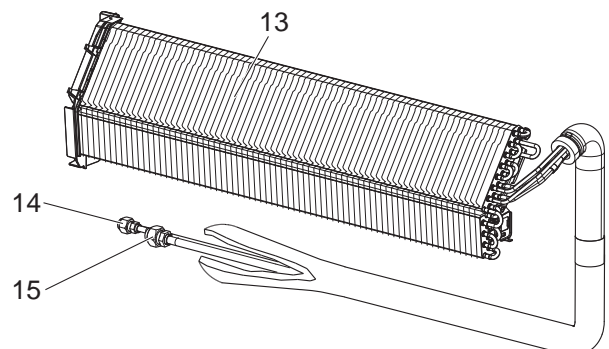

1-1. INDOOR UNIT STRUCTURAL PARTS

1. The part quantity below indicates the required number of pieces per unit.

No.	Part No.	Part name	MSZ-HR25VF- <input type="checkbox"/> E1	MSZ-HR25VF- <input type="checkbox"/> ER1	MSZ-HR25VF- <input type="checkbox"/> ET1	MSZ-HR35VF- <input type="checkbox"/> E1	MSZ-HR35VF- <input type="checkbox"/> ER1	MSZ-HR35VF- <input type="checkbox"/> ET1	Symbol in Wiring Diagram	Remarks
1	G2W 002 026	BOX ASSEMBLY	1	1	1	1	1	1		
2	G2W 001 035	CORNER BOX LEFT	1	1	1	1	1	1		
3	G2W 001 000	PANEL ASSEMBLY	1			1				Includes No. 4, 5, 7, and 9
3	G2W 002 000	PANEL ASSEMBLY		1			1			Includes No. 4, 5, 7, and 9
3	G2W 003 000	PANEL ASSEMBLY			1			1		Includes No. 4, 5, 7, and 9
4	G2W 004 120	ARM HOLDER (LEFT)	1	1	1	1	1	1		
5	G2W 001 118	CATCH	2	2	2	2	2	2		1 PC/SET
6	G2W 001 023	SCREW CAP	2	2	2	2	2	2		1 PC/SET
7	G2W 002 010	FRONT PANEL	1	1	1	1	1	1		
8	G2W 002 100	AIR FILTER	2	2	2	2	2	2		1 PC/SET
9	G2W 003 120	ARM HOLDER (RIGHT)	1	1	1	1	1	1		
10	G2W 001 033	CORNER BOX RIGHT	1	1	1	1	1	1		
11	G2W 002 115	INSTALLATION PLATE	1	1	1	1	1	1		

1-2. ACCESSORY AND REMOTE CONTROLLER

1. The part quantity below indicates the required number of pieces per unit.

No.	Part No.	Part name	MSZ-HR25VF- <input type="checkbox"/> E1	MSZ-HR25VF- <input type="checkbox"/> ER1	MSZ-HR25VF- <input type="checkbox"/> ET1	MSZ-HR35VF- <input type="checkbox"/> E1	MSZ-HR35VF- <input type="checkbox"/> ER1	MSZ-HR35VF- <input type="checkbox"/> ET1	Symbol in Wiring Diagram	Remarks
12	G2W 002 400	REMOTE CONTROLLER	1		1	1		1		RH18A
12	G2W 003 400	REMOTE CONTROLLER		1				1		RH18A

1-3. INDOOR UNIT HEAT EXCHANGER

1. The part quantity below indicates the required number of pieces per unit.

No.	Part No.	Part name	MSZ-HR25VF- <input type="checkbox"/> E1	MSZ-HR25VF- <input type="checkbox"/> ER1	MSZ-HR25VF- <input type="checkbox"/> ET1	MSZ-HR35VF- <input type="checkbox"/> E1	MSZ-HR35VF- <input type="checkbox"/> ER1	MSZ-HR35VF- <input type="checkbox"/> ET1	Symbol in Wiring Diagram	Remarks
13	G2W 005 600	INDOOR HEAT EXCHANGER	1	1	1					
13	G2W 006 600	INDOOR HEAT EXCHANGER				1	1	1		
14	G2W 001 605	UNION (LIQUID)	1	1	1	1	1	1		ø6.35
15	G2W 002 605	UNION (GAS)	1	1	1	1	1	1		ø9.52

MSZ-HR25VF MSZ-HR35VF
1-4. INDOOR UNIT ELECTRICAL PARTS AND FUNCTIONAL PARTS

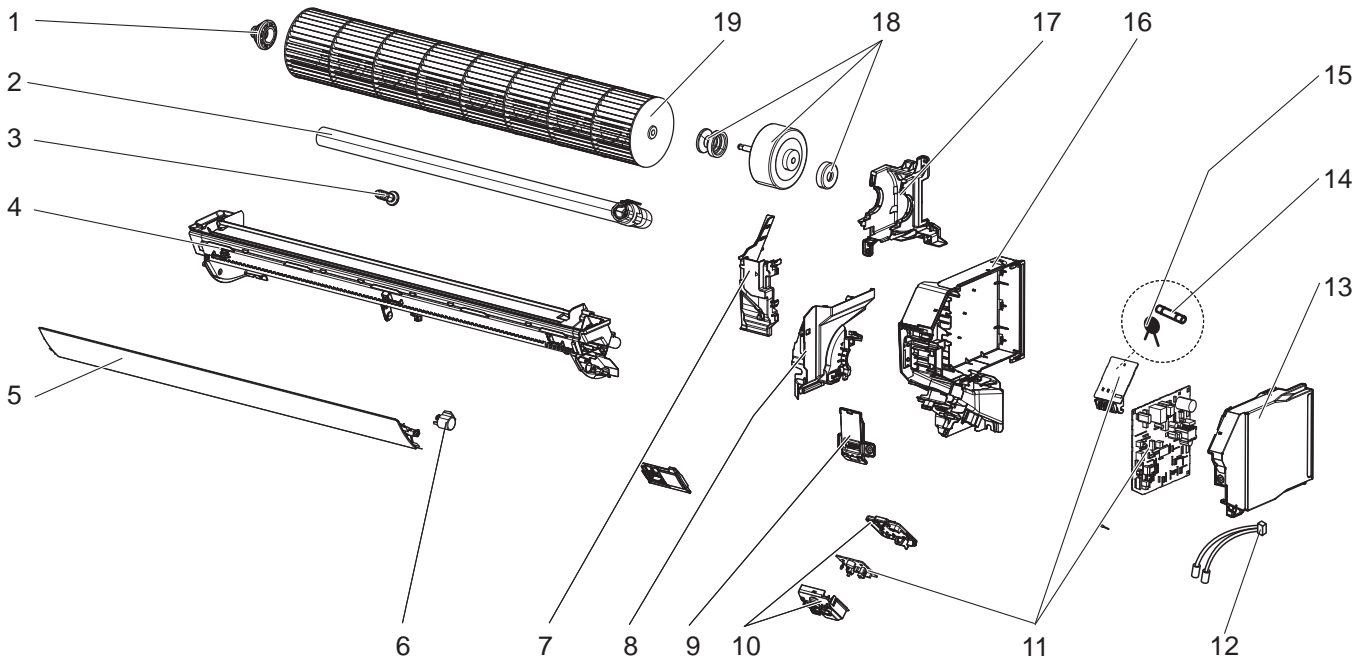

1-4. INDOOR UNIT ELECTRICAL PARTS AND FUNCTIONAL PARTS

1. The part quantity below indicates the required number of pieces per unit.
2. The circled No. indicates that the part is not shown in the figure.

No.	Part No.	Part name	MSZ-HR25VF-E1	MSZ-HR25VF-ERT	MSZ-HR25VF-ET1	MSZ-HR35VF-E1	MSZ-HR35VF-ERT	MSZ-HR35VF-ET1	Symbol in Wiring Diagram	Remarks
1	G2W 002 520	BEARING MOUNT ASSEMBLY	1	1	1	1	1	1		
2	G2W 001 110	DRAIN HOSE	1	1	1	1	1	1		
3	G2W 001 708	DRAIN CAP	1	1	1	1	1	1		
4	G2W 002 030	NOZZLE ASSEMBLY	1	1	1	1	1	1		
5	G2W 003 017	HORIZONTAL VANE	1	1	1	1	1	1		
6	G2W 003 315	VANE MOTOR	1	1	1	1	1	1	MV	UP & DOWN
7	-	WATER COVER	1	1	1	1	1	1		JQ25A311G02
8	G2W 002 103	MOTOR BAND	1	1	1	1	1	1		
9	-	V.A. CLAMP	1	1	1	1	1	1		DK00G275G02
10	-	DISPLAY P.C. BOARD HOLDER	1	1	1	1	1	1		DY25B881G02
11	G2W 008 410	ELECTRONIC CONTROL P.C. BOARD	1	1	1					Includes ROOM TEMPERATURE THERMISTOR (RT11), Terminal P.C. board and power monitor receiver SW P.C. board
11	G2W 007 410	ELECTRONIC CONTROL P.C. BOARD				1	1	1		
12	G2W 003 310	INDOOR COIL THERMISTOR	1	1	1				RT12, RT13	
12	G2W 004 310	INDOOR COIL THERMISTOR				1	1	1	RT12, RT13	
13	-	PB-COVER (RIGHT)	1	1	1	1	1	1		DK00G276G03
14	G2W 002 422	FUSE	1	1	1	1	1	1	F11	
15	G2W 001 425	VARISTOR	1	1	1	1	1	1	NR11	
16	-	PB-COVER (LEFT)	1	1	1	1	1	1		DY00C502G05
17	-	MOTOR BED	1	1	1	1	1	1		SQ00G233G06
18	G2W 001 300	INDOOR FAN MOTOR	1	1	1	1	1	1	MF	RC0J30-□□ Includes FAN MOTOR RUBBER MOUNT (2 PCS/SET)
19	G2W 001 500	LINE FLOW FAN	1	1	1	1	1	1		
⑳	-	LEAD-WIRE	1	1	1	1	1	1		DM00R422G18 Between CN151 on ELECTRONIC CONTROL P.C. BOARD and VANE MOTOR

MSZ-HR42VF MSZ-HR50VF
1-5. INDOOR UNIT STRUCTURAL PARTS

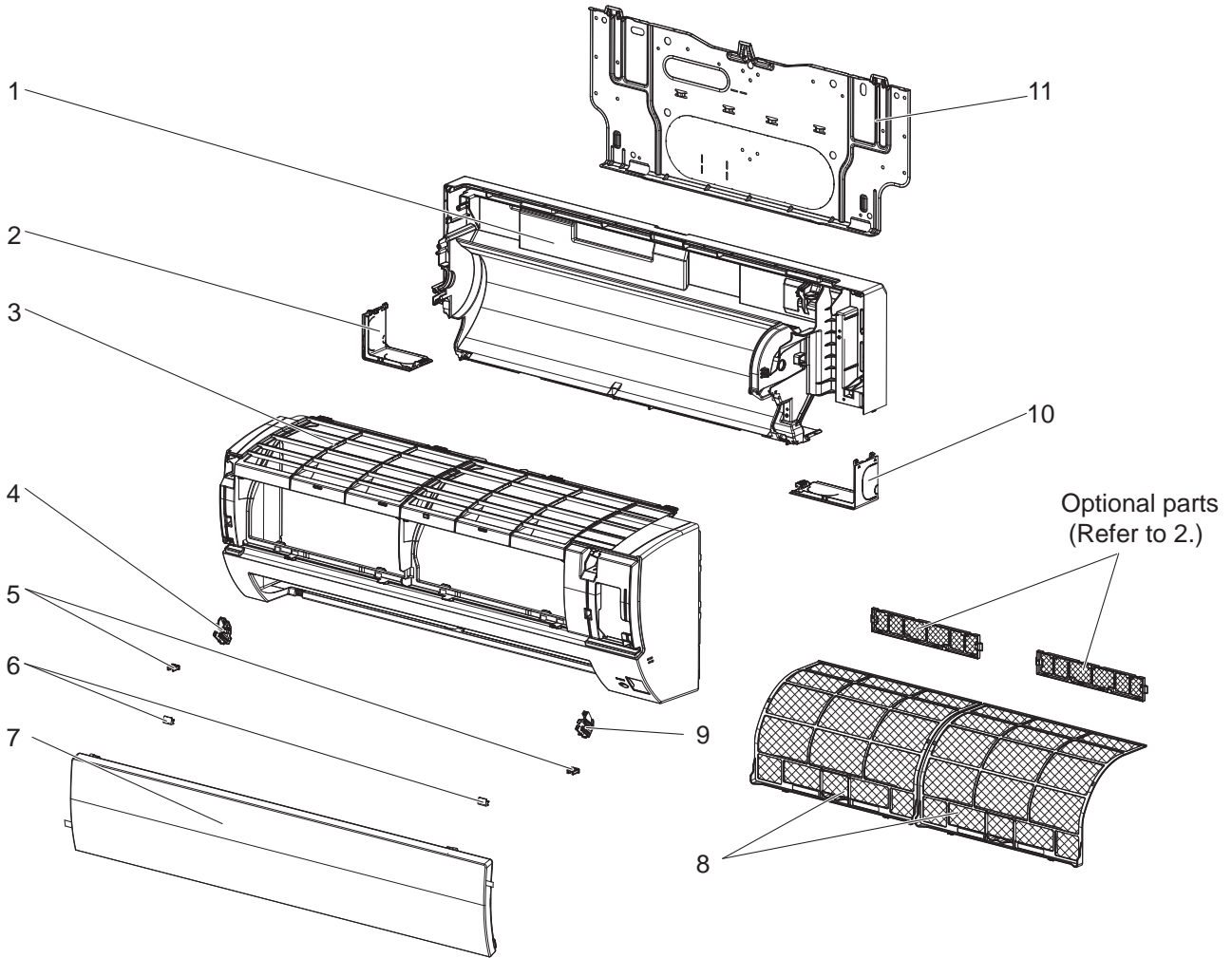

1-6. ACCESSORY AND REMOTE CONTROLLER

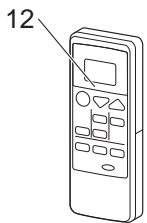

1-7. INDOOR UNIT HEAT EXCHANGER

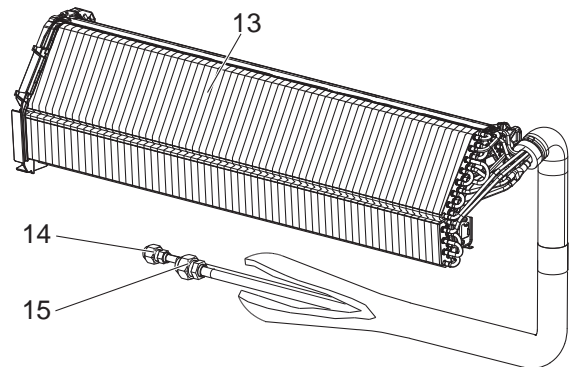

1-5. INDOOR UNIT STRUCTURAL PARTS

1. The part quantity below indicates the required number of pieces per unit.

No.	Part No.	Part name	MSZ-HR42VF- [E1]	MSZ-HR42VF- [ER1]	MSZ-HR42VF- [ET1]	MSZ-HR50VF- [E1]	MSZ-HR50VF- [ER1]	MSZ-HR50VF- [ET1]	Symbol in Wiring Diagram	Remarks
1	G2W 003 026	BOX ASSEMBLY	1	1	1	1	1	1		
2	G2W 001 035	CORNER BOX LEFT	1	1	1	1	1	1		
3	G2W 001 000	PANEL ASSEMBLY	1			1				Includes No. 4, 5, 7, and 9
3	G2W 002 000	PANEL ASSEMBLY		1			1			Includes No. 4, 5, 7, and 9
3	G2W 003 000	PANEL ASSEMBLY			1			1		Includes No. 4, 5, 7, and 9
4	G2W 004 120	ARM HOLDER (LEFT)	1	1	1	1	1	1		
5	G2W 001 118	CATCH	2	2	2	2	2	2		1 PC/SET
6	G2W 001 023	SCREW CAP	2	2	2	2	2	2		1 PC/SET
7	G2W 002 010	FRONT PANEL	1	1	1	1	1	1		
8	G2W 002 100	AIR FILTER	2	2	2	2	2	2		1 PC/SET
9	G2W 003 120	ARM HOLDER (RIGHT)	1	1	1	1	1	1		
10	G2W 001 033	CORNER BOX RIGHT	1	1	1	1	1	1		
11	G2W 002 115	INSTALLATION PLATE	1	1	1	1	1	1		

1-6. ACCESSORY AND REMOTE CONTROLLER

1. The part quantity below indicates the required number of pieces per unit.

No.	Part No.	Part name	MSZ-HR42VF- [E1]	MSZ-HR42VF- [ER1]	MSZ-HR42VF- [ET1]	MSZ-HR50VF- [E1]	MSZ-HR50VF- [ER1]	MSZ-HR50VF- [ET1]	Symbol in Wiring Diagram	Remarks
12	G2W 002 400	REMOTE CONTROLLER	1		1	1		1		RH18A
12	G2W 003 400	REMOTE CONTROLLER		1				1		RH18A

1-7. INDOOR UNIT HEAT EXCHANGER

1. The part quantity below indicates the required number of pieces per unit.

No.	Part No.	Part name	MSZ-HR42VF- [E1]	MSZ-HR42VF- [ER1]	MSZ-HR42VF- [ET1]	MSZ-HR50VF- [E1]	MSZ-HR50VF- [ER1]	MSZ-HR50VF- [ET1]	Symbol in Wiring Diagram	Remarks
13	G2W 007 600	INDOOR HEAT EXCHANGER	1	1	1	1	1	1		
14	G2W 001 605	UNION (LIQUID)	1	1	1	1	1	1		ø6.35
15	G2W 002 605	UNION (GAS)	1	1	1	1	1	1		ø9.52

MSZ-HR42VF MSZ-HR50VF

1-8. INDOOR UNIT ELECTRICAL PARTS AND FUNCTIONAL PARTS

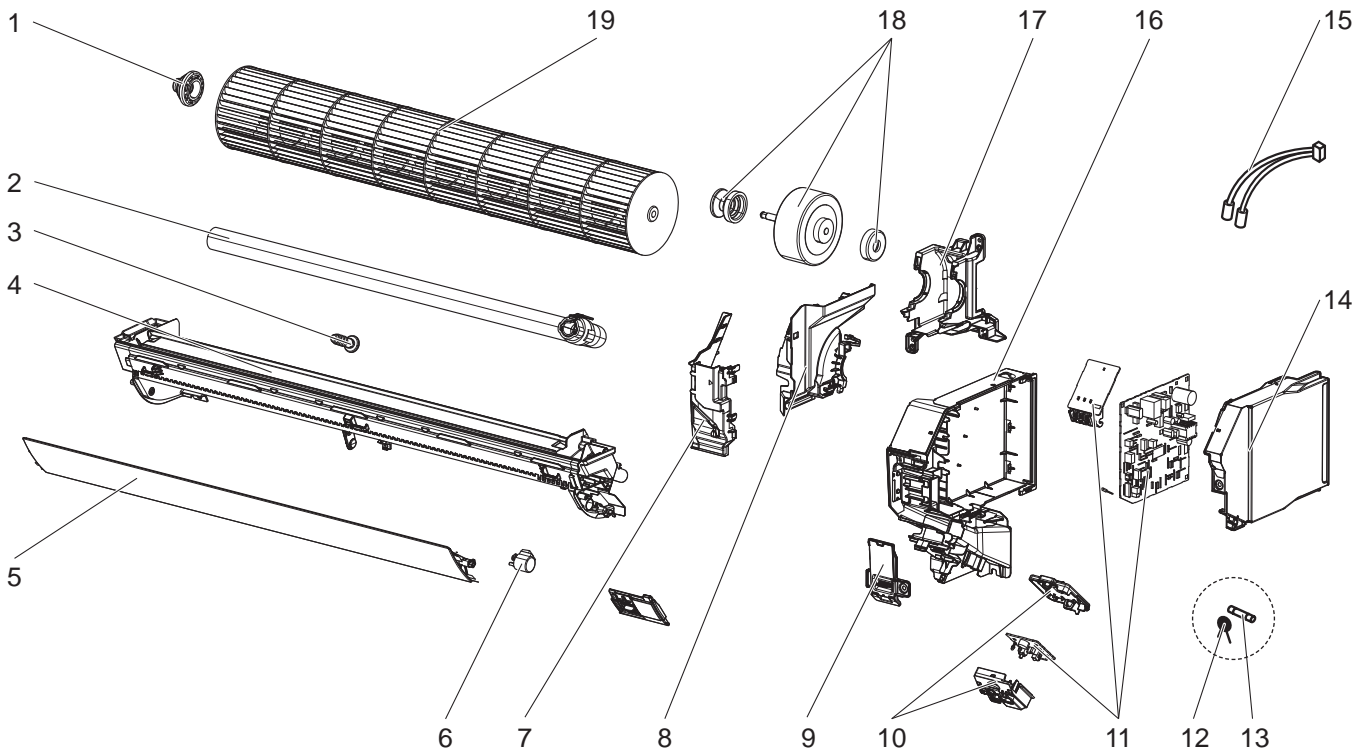

1-8. INDOOR UNIT ELECTRICAL PARTS AND FUNCTIONAL PARTS

1. The part quantity below indicates the required number of pieces per unit.
2. The circled No. indicates that the part is not shown in the figure.

No.	Part No.	Part name	MSZ-HR42VF- <input type="checkbox"/> E1	MSZ-HR42VF- <input type="checkbox"/> ERT	MSZ-HR42VF- <input type="checkbox"/> ET1	MSZ-HR50VF- <input type="checkbox"/> E1	MSZ-HR50VF- <input type="checkbox"/> ERT	MSZ-HR50VF- <input type="checkbox"/> ET1	Symbol in Wiring Diagram	Remarks
1	G2W 002 520	BEARING MOUNT ASSEMBLY	1	1	1	1	1	1		
2	G2W 001 110	DRAIN HOSE	1	1	1	1	1	1		
3	G2W 001 708	DRAIN CAP	1	1	1	1	1	1		
4	G2W 002 030	NOZZLE ASSEMBLY	1	1	1	1	1	1		
5	G2W 003 017	HORIZONTAL VANE	1	1	1	1	1	1		
6	G2W 003 315	VANE MOTOR	1	1	1	1	1	1	MV	UP & DOWN
7	-	WATER COVER	1	1	1	1	1	1		JQ25A311G02
8	G2W 002 103	MOTOR BAND	1	1	1	1	1	1		
9	-	V.A. CLAMP	1	1	1	1	1	1		DK00G275G02
10	-	DISPLAY P.C. BOARD HOLDER	1	1	1	1	1	1		DY25B881G02
11	G2W 006 410	ELECTRONIC CONTROL P.C. BOARD	1	1	1					Includes ROOM TEMPERATURE THERMISTOR (RT11), Terminal P.C. board and power monitor receiver SW P.C. board
11	G2W 005 410	ELECTRONIC CONTROL P.C. BOARD				1	1	1		
12	G2W 001 425	VARISTOR	1	1	1	1	1	1	NR11	
13	G2W 002 422	FUSE	1	1	1	1	1	1	F11	
14	-	PB-COVER (RIGHT)	1	1	1	1	1	1		DK00G276G03
15	G2W 005 310	INDOOR COIL THERMISTOR	1	1	1	1	1	1	RT12,RT13	
16	-	PB-COVER (LEFT)	1	1	1	1	1	1		DY00C502G05
17	-	MOTOR BED	1	1	1	1	1	1		SQ00G233G06
18	G2W 001 300	INDOOR FAN MOTOR	1	1	1	1	1	1	MF	RC0J30- <input type="checkbox"/> <input type="checkbox"/> Includes FAN MOTOR RUBBER MOUNT (2 PCS/SET)
19	G2W 001 500	LINE FLOW FAN	1	1	1	1	1	1		
⑳	-	LEAD-WIRE	1	1	1	1	1	1		DM00R422G18 Between CN151 on ELECTRONIC CONTROL P.C. BOARD and VANE MOTOR

MSZ-HR60VF MSZ-HR71VF
1-9. INDOOR UNIT STRUCTURAL PARTS

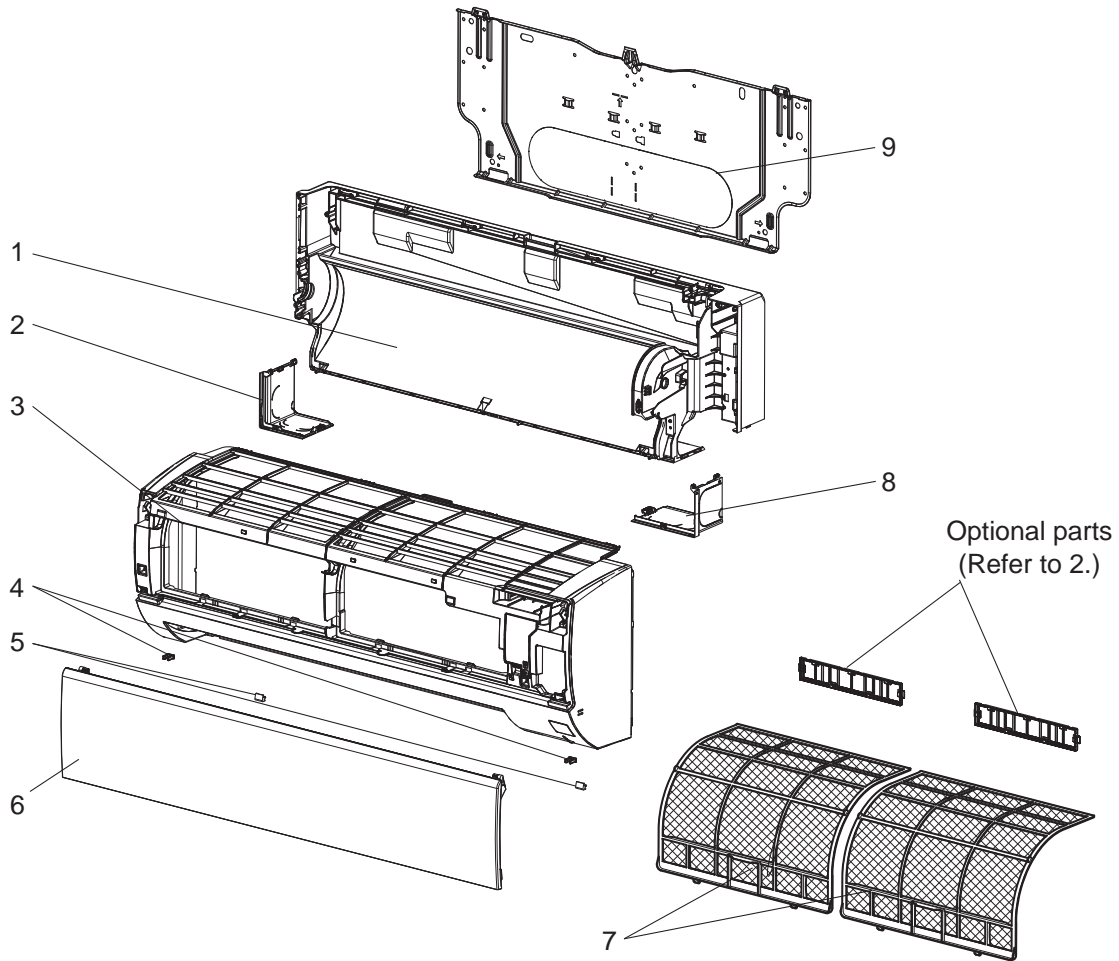

1-10. ACCESSORY AND REMOTE CONTROLLER 1-11. INDOOR UNIT HEAT EXCHANGER

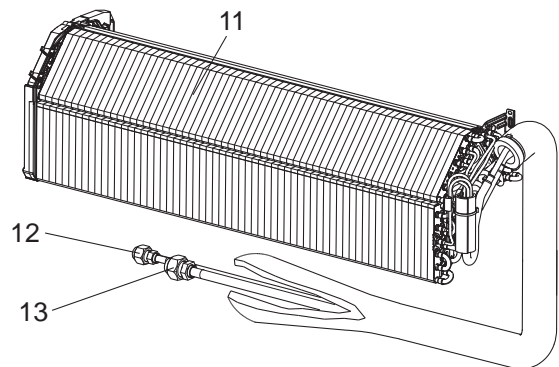
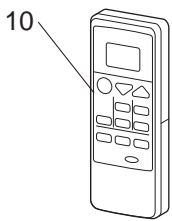

1-9. INDOOR UNIT STRUCTURAL PARTS

1. The part quantity below indicates the required number of pieces per unit.

No.	Part No.	Part name	MSZ-HR60VF-	MSZ-HR60VF-	MSZ-HR60VF-	MSZ-HR60VF-	MSZ-HR71VF-	MSZ-HR71VF-	MSZ-HR71VF-	Symbol in Wiring Diagram	Remarks
			E1	ER1	ET1	E2	E1	ER1	ET1		
1	E22 44C 234	BOX ASSEMBLY	1	1	1	1	1	1	1		
2	E22 98B 976	CORNER BOX LEFT	1	1	1	1	1	1	1		
3	E22 42K 000	PANEL ASSEMBLY	1	1	1	1	1	1	1		Includes No. 4, 5 and 6
4	E22 F95 142	CATCH	2	2	2	2	2	2	2		2 PCS/SET
5	E22 98B 067	SCREW CAP	2	2	2	2	2	2	2		2 PCS/SET
6	E22 42K 010	FRONT PANEL	1	1	1	1	1	1	1		
7	E22 N87 100	AIR FILTER	2	2	2	2	2	2	2		1 PC/SET
8	E22 98B 975	CORNER BOX RIGHT	1	1	1	1	1	1	1		
9	E22 N87 970	INSTALLATION PLATE	1	1	1	1	1	1	1		

1-10. ACCESSORY AND REMOTE CONTROLLER

1. The part quantity below indicates the required number of pieces per unit.

No.	Part No.	Part name	MSZ-HR60VF-	MSZ-HR60VF-	MSZ-HR60VF-	MSZ-HR60VF-	MSZ-HR71VF-	MSZ-HR71VF-	MSZ-HR71VF-	Symbol in Wiring Diagram	Remarks
			E1	ER1	ET1	E2	E1	ER1	ET1		
10	E22 42K 426	REMOTE CONTROLLER	1		1	1	1		1		RH18A
10	E22 44K 426	REMOTE CONTROLLER		1				1			RH18A

1-11. INDOOR UNIT HEAT EXCHANGER

1. The part quantity below indicates the required number of pieces per unit.

No.	Part No.	Part name	MSZ-HR60VF-	MSZ-HR60VF-	MSZ-HR60VF-	MSZ-HR60VF-	MSZ-HR71VF-	MSZ-HR71VF-	MSZ-HR71VF-	Symbol in Wiring Diagram	Remarks
			E1	ER1	ET1	E2	E1	ER1	ET1		
11	E22 42K 620	INDOOR HEAT EXCHANGER	1	1	1	1	1	1	1		
12	E22 151 667	UNION (LIQUID)	1	1	1	1	1	1	1		ø6.35
13	E22 179 667	UNION (GAS)	1	1	1	1	1	1	1		ø12.7

MSZ-HR60VF MSZ-HR71VF
1-12. INDOOR UNIT ELECTRICAL PARTS AND FUNCTIONAL PARTS

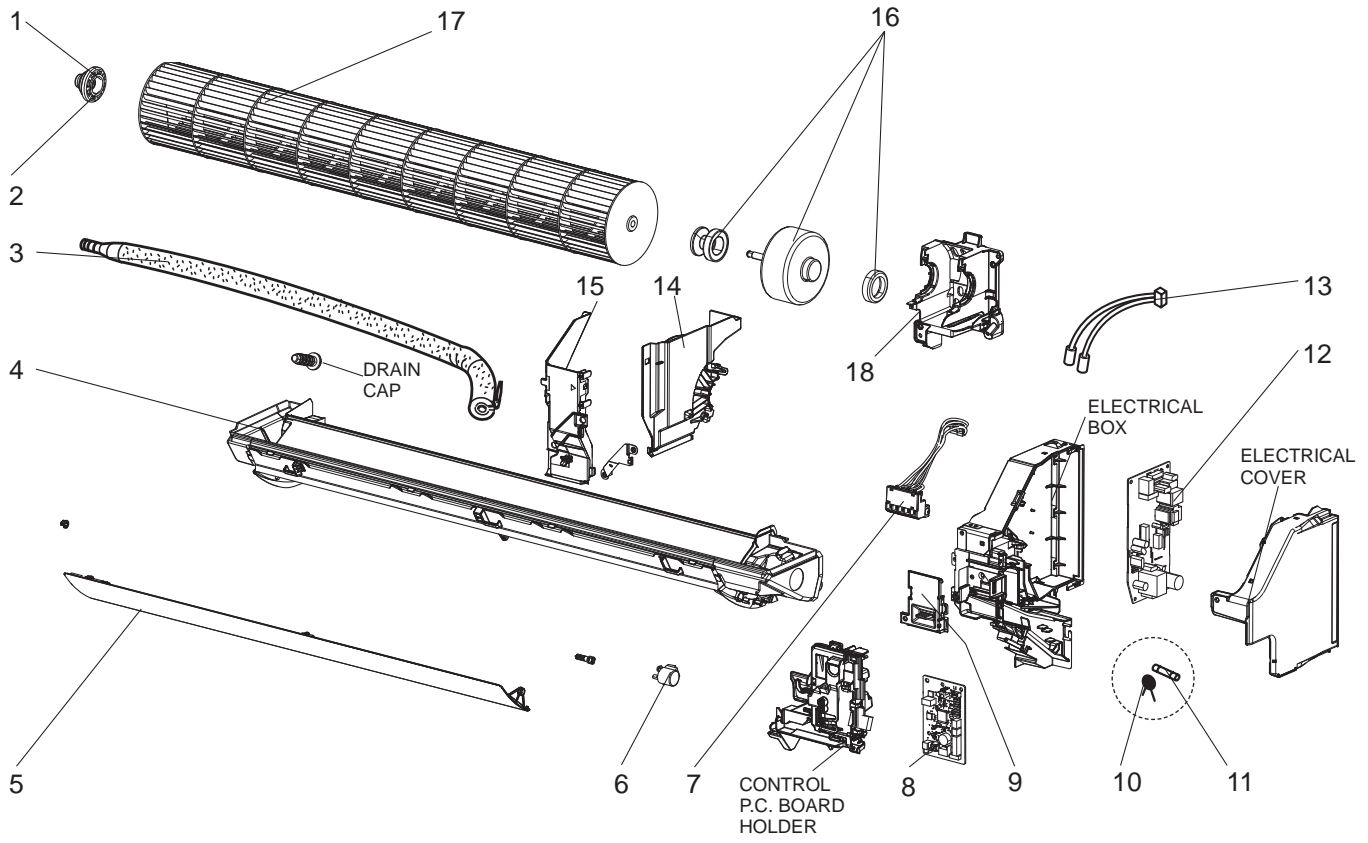

1-12. INDOOR UNIT ELECTRICAL PARTS AND FUNCTIONAL PARTS

1. The part quantity below indicates the required number of pieces per unit.

No.	Part No.	Part name	MSZ-HR60VF- <input type="checkbox"/> E1	MSZ-HR60VF- <input type="checkbox"/> ER1	MSZ-HR60VF- <input type="checkbox"/> ET1	MSZ-HR60VF- <input type="checkbox"/> E2	MSZ-HR71VF- <input type="checkbox"/> E1	MSZ-HR71VF- <input type="checkbox"/> ER1	MSZ-HR71VF- <input type="checkbox"/> ET1	MSZ-HR71VF- <input type="checkbox"/> E2	Symbol in Wiring Diagram	Remarks
1	E22 A89 509	BEARING MOUNT ASSEMBLY				1				1		Includes SLEEVE BEARING
1	E22 751 509	BEARING MOUNT	1	1	1		1	1	1			
2	E22 001 504	SLEEVE BEARING	1	1	1		1	1	1			
3	E22 P72 702	DRAIN HOSE	1	1	1	1	1	1	1	1		
4	E22 42K 235	NOZZLE ASSEMBLY	1	1	1	1	1	1	1	1		Full assembly except DRAIN HOSE
5	E22 42K 040	HORIZONTAL VANE	1	1	1	1	1	1	1	1		
6	E22 N87 303	VANE MOTOR	1	1	1	1	1	1	1	1	MV	UP & DOWN, 1 PC/SET
7	E22 N94 375	TERMINAL BLOCK ASSEMBLY	1	1	1	1	1	1	1	1	TB	Lead wire attached
8	E22 42K 452	CONTROL P.C. BOARD	1	1	1	1						Includes ROOM TEMPERATURE THERMISTOR (RT11)
8	E22 43K 452	CONTROL P.C. BOARD					1	1	1	1		
9	E22 N87 784	V.A. CLAMP	1	1	1	1	1	1	1	1		
10	E22 K90 385	VARISTOR	1	1	1	1	1	1	1	1	NR11	
11	E22 42J 382	FUSE	1	1	1	1	1	1	1	1	F11	T3.15AL250V
12	E22 42K 440	POWER P.C. BOARD	1	1	1	1	1	1	1	1		
13	E22 R84 307	INDOOR COIL THERMISTOR	1	1	1	1	1	1	1	1	RT12, RT13	
14	E22 N87 333	MOTOR BAND	1	1	1	1	1	1	1	1		
15	E22 42K 541	WATER COVER	1	1	1	1	1	1	1	1		
16	E22 29L 300	INDOOR FAN MOTOR	1	1	1	1	1	1	1	1	MF	RC0J40- <input type="checkbox"/> <input type="checkbox"/> Includes FAN MOTOR RUBBER MOUNT (2 PCS/SET)
17	E22 N87 302	LINE FLOW FAN	1	1	1	1	1	1	1	1		
18	E22 18A 333	MOTOR BED				1				1		

2-1. AIR CLEANING FILTER (SILVER-IONIZED AIR PURIFIER FILTER)

Model	Part No.
MSZ-HR25VF MSZ-HR35VF MSZ-HR42VF MSZ-HR50VF MSZ-HR60VF MSZ-HR71VF	MAC-2370FT-E

Every 3 months:

- Remove dirt by a vacuum cleaner.

When dirt cannot be removed by vacuum cleaning:

- Soak the filter and its frame in lukewarm water before rinsing it.
- After washing, dry it well in shade. Install all tabs of the air filter.

Every year:

- Replace it with a new air cleaning filter for best performance.

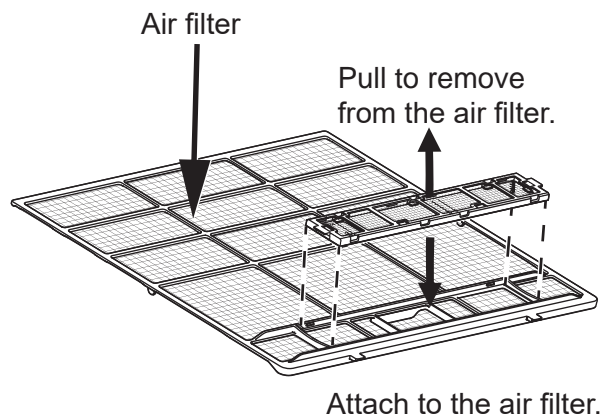

MITSUBISHI ELECTRIC CORPORATION

HEAD OFFICE: TOKYO BUILDING, 2-7-3, MARUNOUCHI, CHIYODA-KU, TOKYO 100-8310, JAPAN

© Copyright 2018 MITSUBISHI ELECTRIC CORPORATION

Issued: Feb. 2021. No. OBB822 REVISED EDITION-D

Issued: Feb. 2020. No. OBB822 REVISED EDITION-C

Issued: Jan. 2020. No. OBB822 REVISED EDITION-B

Issued: Apr. 2019. No. OBB822 REVISED EDITION-A

Published: Oct. 2018. No. OBB822

Made in Japan

Specifications are subject to change without notice.