

幅面: A4  
比例: 1:1

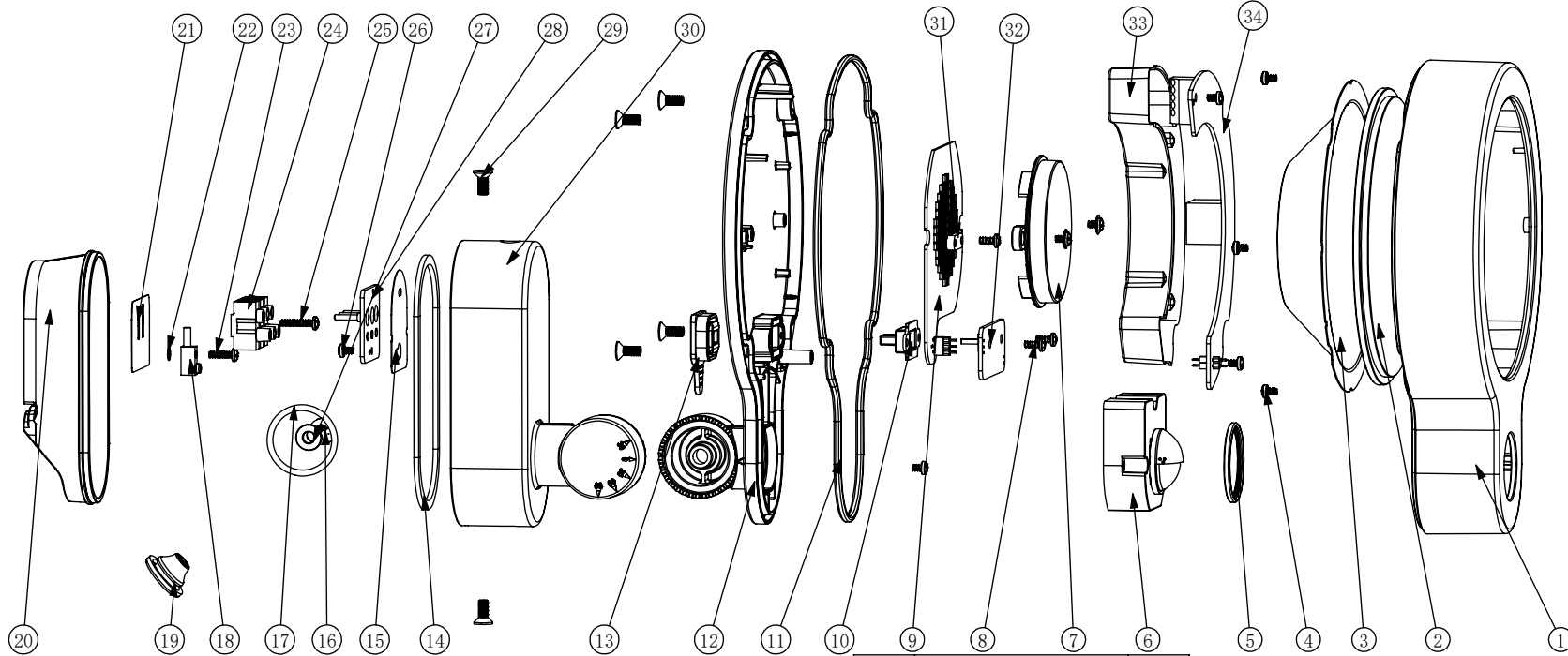

NO.	Description	Quan.
1	PIR cover	1
2	Glass	1
3	Reflector	1
4	Screw strip 2.9X4.0	6
5	Waterproof-washer	1
6	Light controller	1
7	Hood	1
8	Screw ST2.9X6.5	6
9	Aluminum plate	1
10	Silicone cover	1
11	Foamed silicone	1
12	Back cover	1
13	Sealing plug	1
14	Base seal	1
15	Base insulate sheet	1
16	Screw M6X20	1
17	Shaft seal	1
18	Terminal	1
19	Guard coil	1
20	Bottom plate	1

NO.	Description	Quan.	NO.	Description	Quan.
21	Bottom insulate sheet	1	29	Screw M4X10	6
22	WasherΦ3	1	30	Base	1
23	Screw ST2.9X10	1	31	Crimping clip	1
24	Terminal	1	32	Palette	1
25	Screw ST2.9X14	3	33	Drive blister box	1
26	Screw ST2.9X4.0	2	34	Driver PCB	1
27	Shaft ring	1			
28	Adapter board	1			

第一视角		
尺寸(mm)	公差	角度公差
0-(10)	±0.10	±1°
10-(50)	±0.15	
50-(100)	±0.20	
100-(160)	±0.30	
>160	±0.40	

版本	DCN NO.	修改描述	修订日期
未做特殊说明 单位为毫米(mm)			



图纸名称: FOGGY-光控版爆炸图		
图号:	编制日期: 2022/03/05	第 01 页
版本号: V01		共 01 页

未经公司允许, 该文档和数据不得全部或部分复制