

# YL-AD01-S1

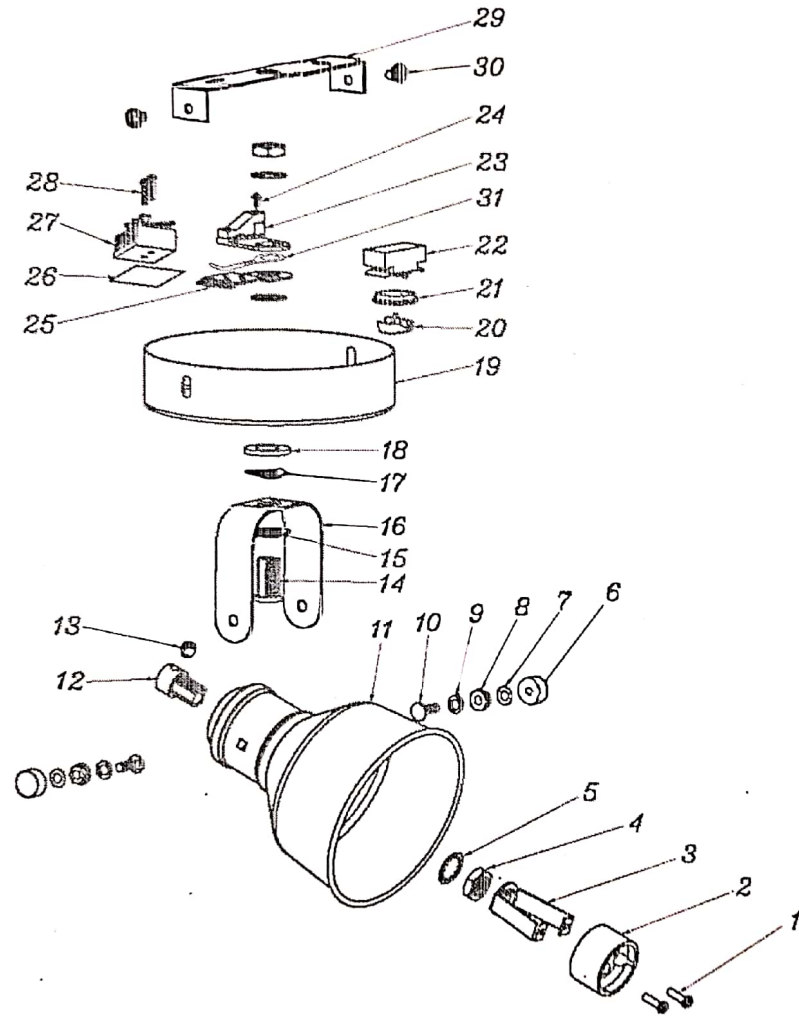

Serial number	Part name	Quantity
1	Cross round head machine wire M3*10	2
2	GU10 Ceramic lamp holder	1
3	30 Lamp holder support	1
4	M10 Nut	2
5	M10 Inner chrysanthemum	5
6	M4 Decorative Cap	2
7	D4 wave medium	2
8	M4 with a medium nut	2
9	D8 Nylon pad	2
10	M4 Carriage screw	2
11	88 Lampshade	1
12	ADEO20 lock wire piece	1
13	M6 plastic screws	1
14	Trimming software	1
15	Gear plate	1
16	U-bracket A	1
17	M10 Wave medium	1
18	D20 Nylon pad	1
19	110 disc	1
20	Rocker switch module A	1
21	Rocker switch module B	1
22	Rocker switch module C	1
23	Wire pressing plate	1
24	M3*6 Flat foot self-tapping screws	1
25	Terminal fixer	1
26	Insulating paper	1
27	3-bit quick-connect terminal	1
28	Cross round head machine wire M3*10	2
29	107 Hanging Plate	1
30	M4*6 with tooth tape interface	2
31	Grounding cable	2

