

**TB 76T-S**

13A726JD609

2024

Table-No.:	Description
E3-07659E-01	Palier 618-04822B
813-050115-17	Relevage plateau de coupe
E3-07636B-01	Enclenchement plateau de coupe
813-050257-13	"Plateau de coupe D (30"/76cm)"
E3-04024B-01	Tuyère nettoyage
813-010305-00	Volant
E3-07634F-01	Tige de frein, Tige de commande, Pedale
E3-07650C-01	Roues 13x5x6; 16x6,5x8
813-050349-07	Système direction
813-050138-36	Entraînement de roulement
813-050163-06	Réservoir
813-050862-06	Commande de choke et gaz, Poulie moteur, Accessoires moteur
813-050962-01	Châssis
E3-08294M-01	Moteur
E3-07649A-01	Pare-chocs
E3-07654D-01	couverture
E3-09179B-01	Marchepied
813-051024-00	Habillages
E3-10199C-01	Siège, Support de siège
E3-10900A-01	Clé
E3-02343G-01	Batterie
813-051011-00	Assortiment électrique

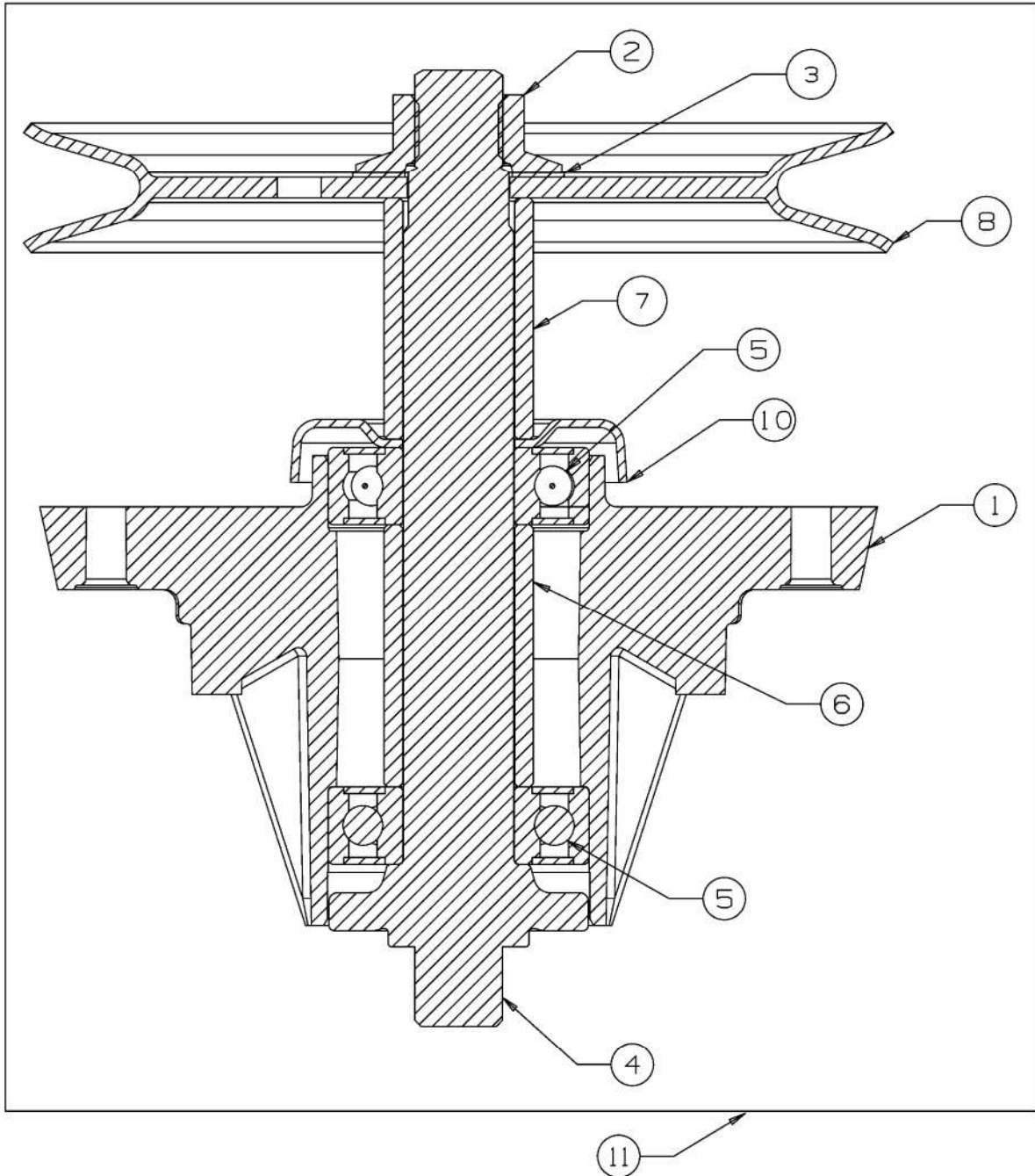
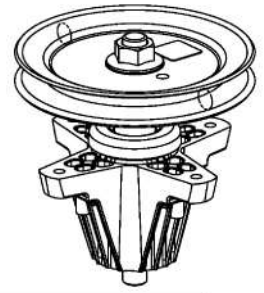

E3-07659E-01

## Palier 618-04822B

Fig.	No. Pièces	Désignation	Numero de la norme	Nbr.
1	619-04183B	CORPS DE PALIER	FINISH:WIE GEGOSSEN	1
2	712-05134	ECROU	FINISH:MTD SPEC-100015+WAX	1
3	736-0351	RONDELLE .75x1.50"	FINISH:MTD SPEC-100016	1
4	738-1186A	AXE DE PALIER DE LAME	FINISH:GEÖLT	1
5	741-0919B	ROULEMENT DE PALIER DE LAME	FINISH:	2
6	750-04936	ENTRETOISE	FINISH:GEÖLT	1
7	750-06390	ENTRETOISE	FINISH:GEÖLT	1
8	756-05111	POULIE DE PALIER DE LAME	FINISH:SPEC-100015	1
10	783-08435	PROTECTION DE ROULEMENT	FINISH:SPEC-701-101625	1
11	618-04822B	PALIER DE LAME COMPLET	Ø 6.3":FINISH 918-04822B	1

Relevage plateau de coupe

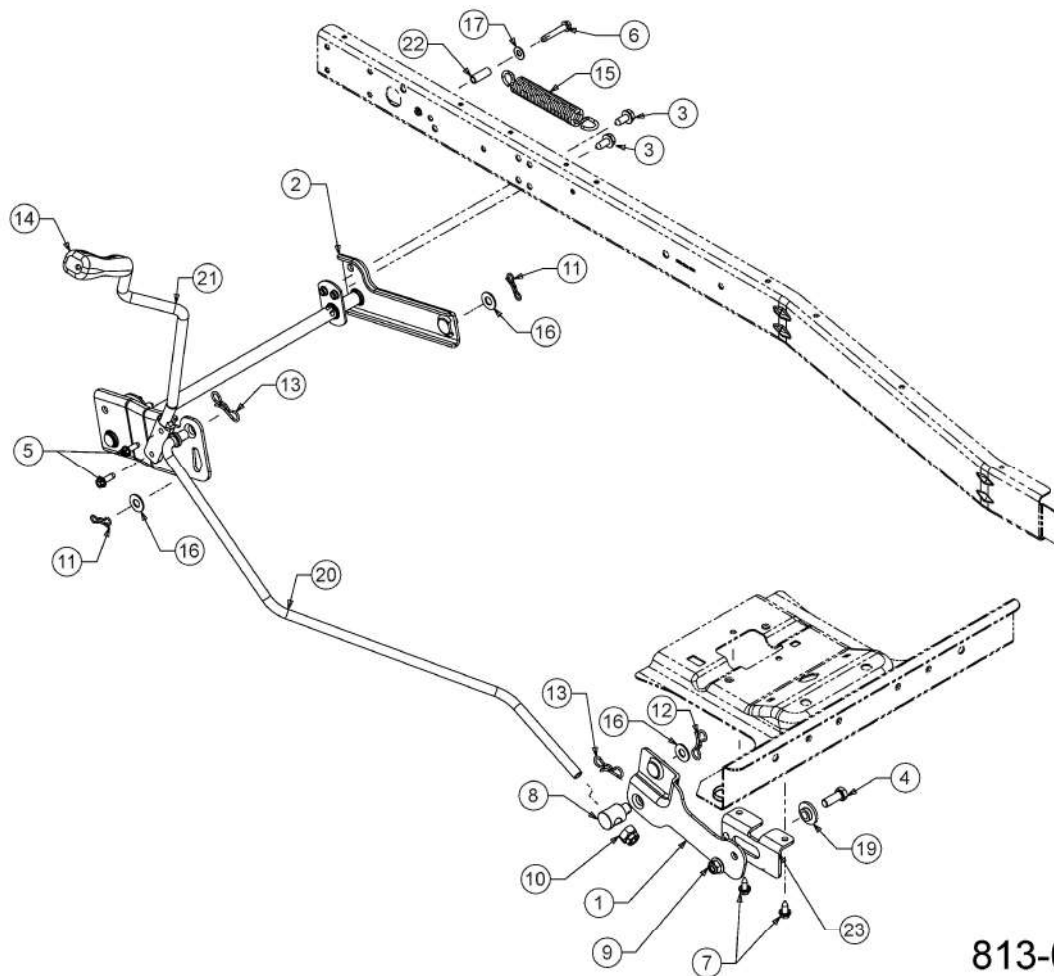

813-050115-17

## Relevage plateau de coupe

Fig.	No. Pièces	Désignation	Numero de la norme	Nbr.
1	683-04757			1
2	683-05060			1
3	710-04484	VIS HEX. TT:5/16-18.:750:HXIND	FINISH:MTD SPEC-100016 TYPE 1	4
4	710-0514	VIS HEX.:3/8-16:1.00:GR5:STD	FINISH:MTD SPEC-100015	1
5	710-0642	VIS1/4-20:0.750	SPEC-100016 TYPE 1 910-0642	2
6	710-0778	VIS HEX. TT:1/4-20:1.500	FINISH:MTD SPEC-100016 TYPE 1	1
7	710-1652	VIS HEX. TT:1/4-20:.625:HXINDW	FINISH:MTD-SPEC-100016 TYPE 1	2
8	711-05690C	FERRURE	FINISH:MTD SPEC-100015	1
9	712-04065	ECROU HEXAGONAL	FINISH:SPEC-100015 912-04065	1
10	712-04243	ECROU	FINISH:MTD SPEC-100015	1
11	714-04040	GOUPILLE	FINISH:ASTM F1941 FE/ZN 3AN	2
12	714-04043	GOUPILLE	FINISH:VERZINKT	1
13	714-05005	GOUPILLE	FINISH:ASTM F1941 FE/ZN 3AN	2
14	720-0311	POIGNÛE LEVIER COUPE : 1/2	FARBE:Schwarz VINYL	1
15	732-04692	RESSORT	FINISH:PHOS & OIL	1
16	736-0300	RONDELLE	FINISH:MTD SPEC-100015	3
17	1751	RONDELLTE	1751	1
19	738-0347	RONDELLE j EMB. .625IDx.169	FINISH:	1
20	747-05511	TRINGLE DE RELEVAGE	747-05511	1
21	747-05576			1
22	750-0566A	ENTRETOISE	FINISH:MTD SPEC-100015	1
23	783-07129			1

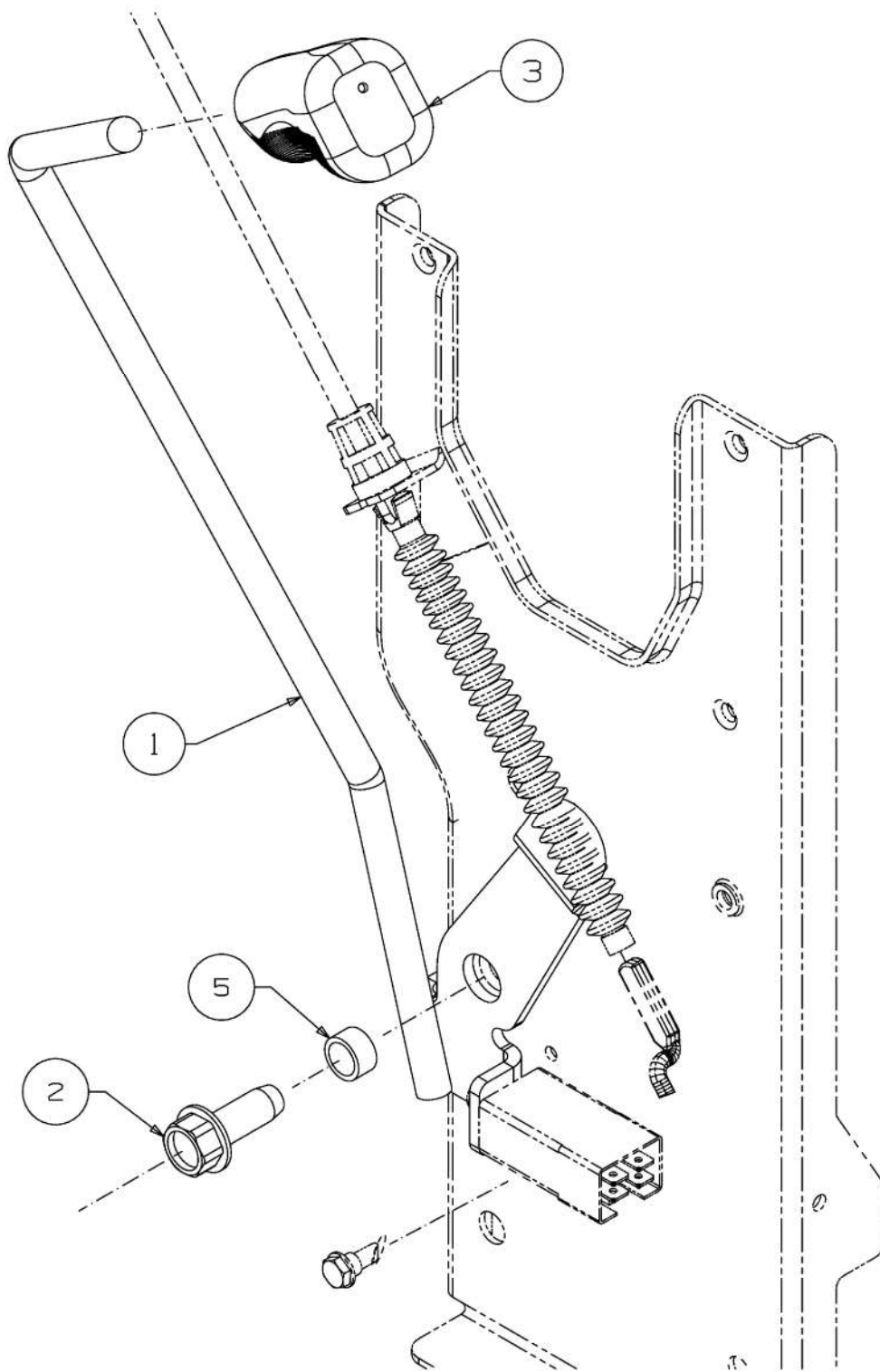

E3-07636B-01

## Enclenchement plateau de coupe

Fig.	No. Pièces	Désignation	Numero de la norme	Nbr.
1	683-04754637	LEVIER D EMBRAYAGE	683-04754637	1
2	710-04683	VIS HEX.:3/8-16:1.000	FINISH:MTD SPEC-701-01002	1
3	720-04049A	POIGNEE PLASTIQUE	FINISH: SCHWARZ	1
5	750-0526	ENTRETOISE 380 IDX 50 ODX 265	FINISH: MTD SPEC-100015	1



"Plateau de coupe D (30"/76cm)"

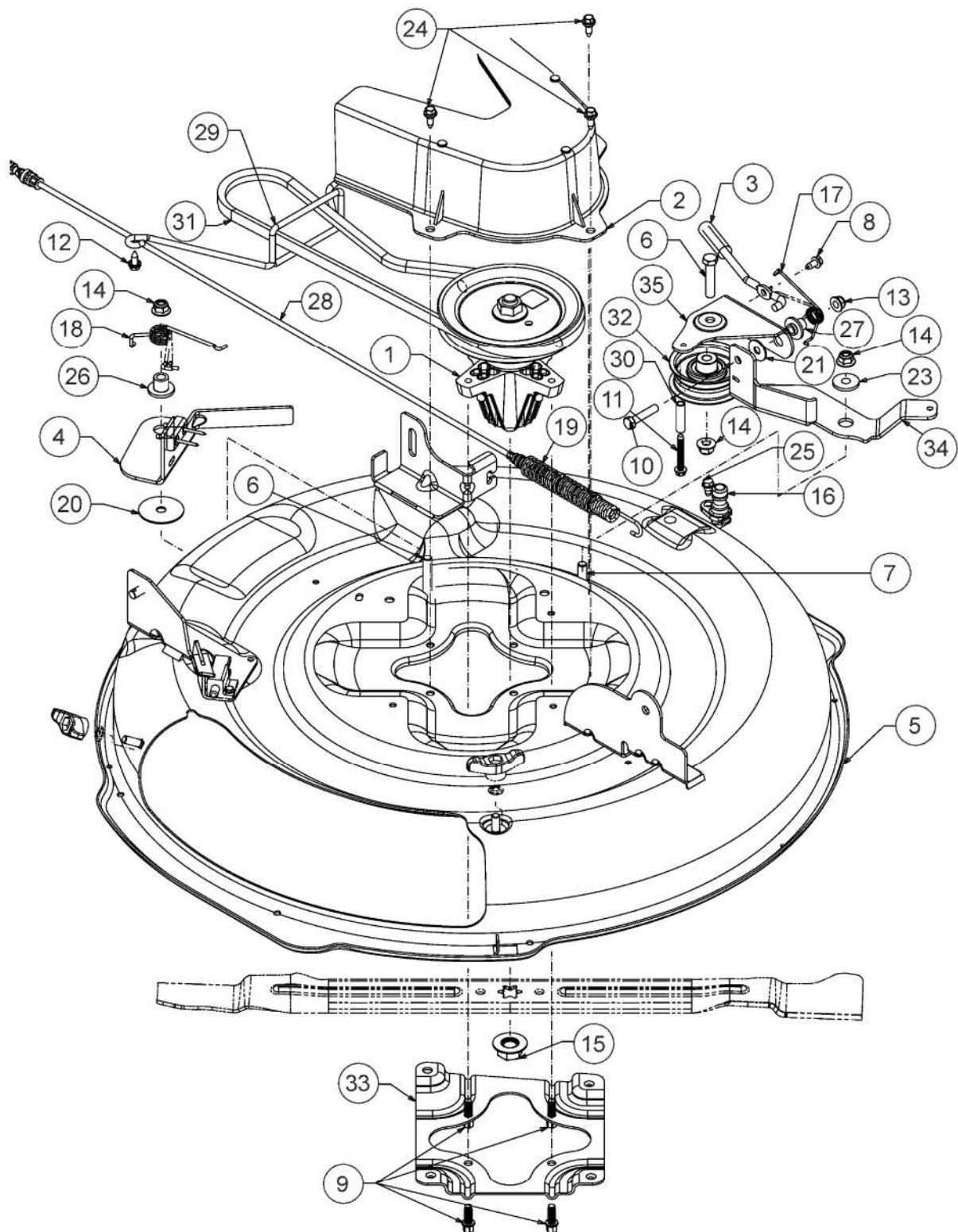

813-050257-13

## "Plateau de coupe D (30"/76cm)"

Fig.	No. Pièces	Désignation	Numero de la norme	Nbr.
1	618-04822B	PALIER DE LAME COMPLET	Ø 6.3":FINISH 918-04822B	1
2	631-05024	CARTER PROTECTION DE COURROIE	631-05024	1
3	647-05028	LEVIER	647-05028	1
4	683-05034	FREIN DE LAME	UND NIETEN	1
5	683-05039E-S	CARTER DE COUPE 76 CM	683-05039E-S	1
6	710-0347	VIS HEX. 3/8-16:1.75:GR5:STD	FINISH:MTD SPEC-100015	2
7	710-0514	VIS HEX.:3/8-16:1.00:GR5:STD	FINISH:MTD SPEC-100015	1
8	710-0599	VIS A SIX PANS CREUX	FINISH:MTD SPEC-101617	1
9	710-06322	VIS	FINISH:SPEC-100016 TYPE 1	4
10	710-0805A	VIS HEX.:5/16-18:1.50:GR5:STD	FINISH:MTD SPEC-100015	1
11	710-1026	VIS HEX.TT:1/4-20:1.750	FINISH:MTD-SPEC-100016	1
12	710-1652	VIS HEX. TT:1/4-20:1.625:HXINDW	FINISH:MTD-SPEC-100016 TYPE 1	1
13	712-04063	ECROU HEX. AVEC FLANC	FINISH:MTD SPEC-100015	1
14	712-04065	ECROU HEXAGONAL	FINISH:SPEC-100015 912-04065	3
15	712-05134	ECROU	FINISH:MTD SPEC-100015+WAX	1
16	731-07487	BUSE DE NETTOYAGE PLATEAU	FINISH:SCHWARZ 788-0637	1
17	732-05045	RESSORT	FINISH:SPEC-100015	1
18	732-05046	RESSORT	FINISH:SPEC-701-01006	1
19	732-0583	RESSORT	FINISH:PHOS & OILx	1
20	736-3040	RONDELLE	FINISH:MTD STD 701-01000	1
21	736-3078	RONDELLE .344 x 1.00 x .063:HT	FINISH:701-01001	1
23	738-0347	RONDELLE j EMB. .625IDx.169	FINISH:	1
24	738-04184A	VIS A EPAULE:.368x.113:TT:1/4-	TT:FINISH MTD SPEC-100016	3
25	738-04278	VIS	FINISH:MTD STD SPEC-100016	1
26	738-05021	ENTRETOISE	FINISH:DAMPF BEHANDELT	1
27	738-05022	ENTRETOISE	FINISH:DAMPF BEHANDELT	1
28	746-04802A	CABLE PTO	FINISH: SIEHE ZG.	1
29	747-06126A	GUIDE COURROIE	747-06126A	1
30	750-04456	ENTRETOISE	FINISH:MTD SPEC-100015	1
31	754-05001	COURROIE DE LAME MINIRIDER	FINISH: N/A	1
32	756-04224	POULIE TENDEUR	BLK ECOAT,PAINT OR SPEC-100015	1
33	783-08047A	RENFORT CARTER DE COUPE	783-08047A	1
34	783-08128	SUPPORT	FINISH:SPEC-100015 CR-12	1
35	783-08226A			1

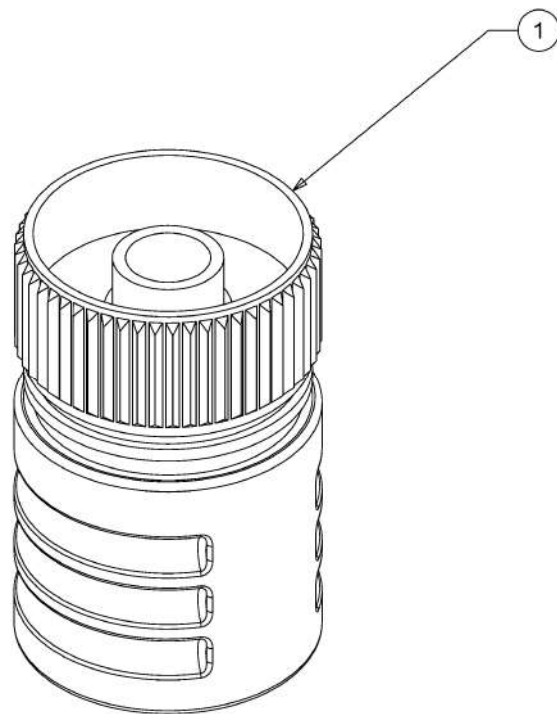

E3-04024B-01

## Tuyère nettoyage

Fig.	No. Pièces	Désignation	Numero de la norme	Nbr.
1	721-04041	ADAPTATEUR BUSE DE LAVAGE	FINISH: 921-04041	1

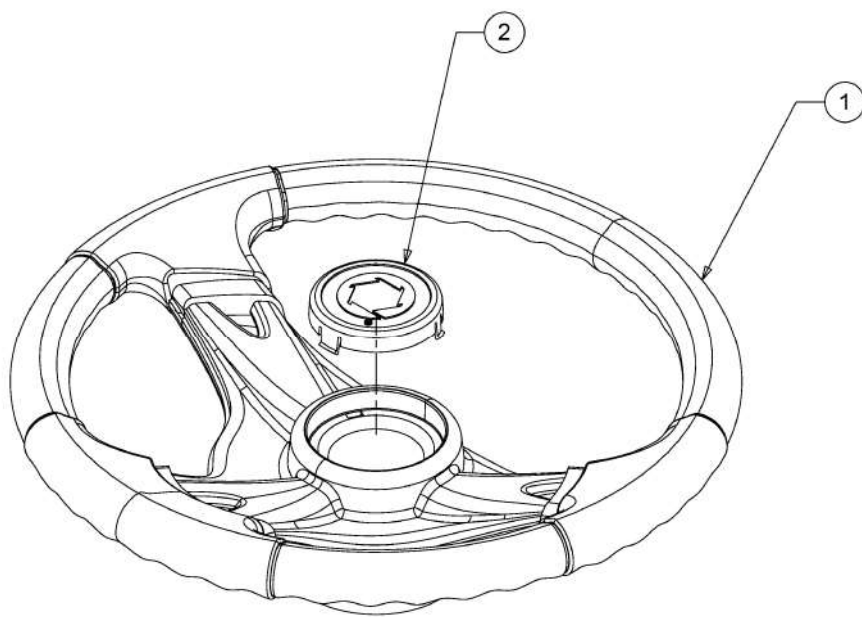

813-010305-00

# Volant

Fig.	No. Pièces	Désignation	Numero de la norme	Nbr.
1	631-04028	VOLANT	FINISH SCHWARZ	1
2	731-04681		FINISH: SCHWARZ NON CE	1

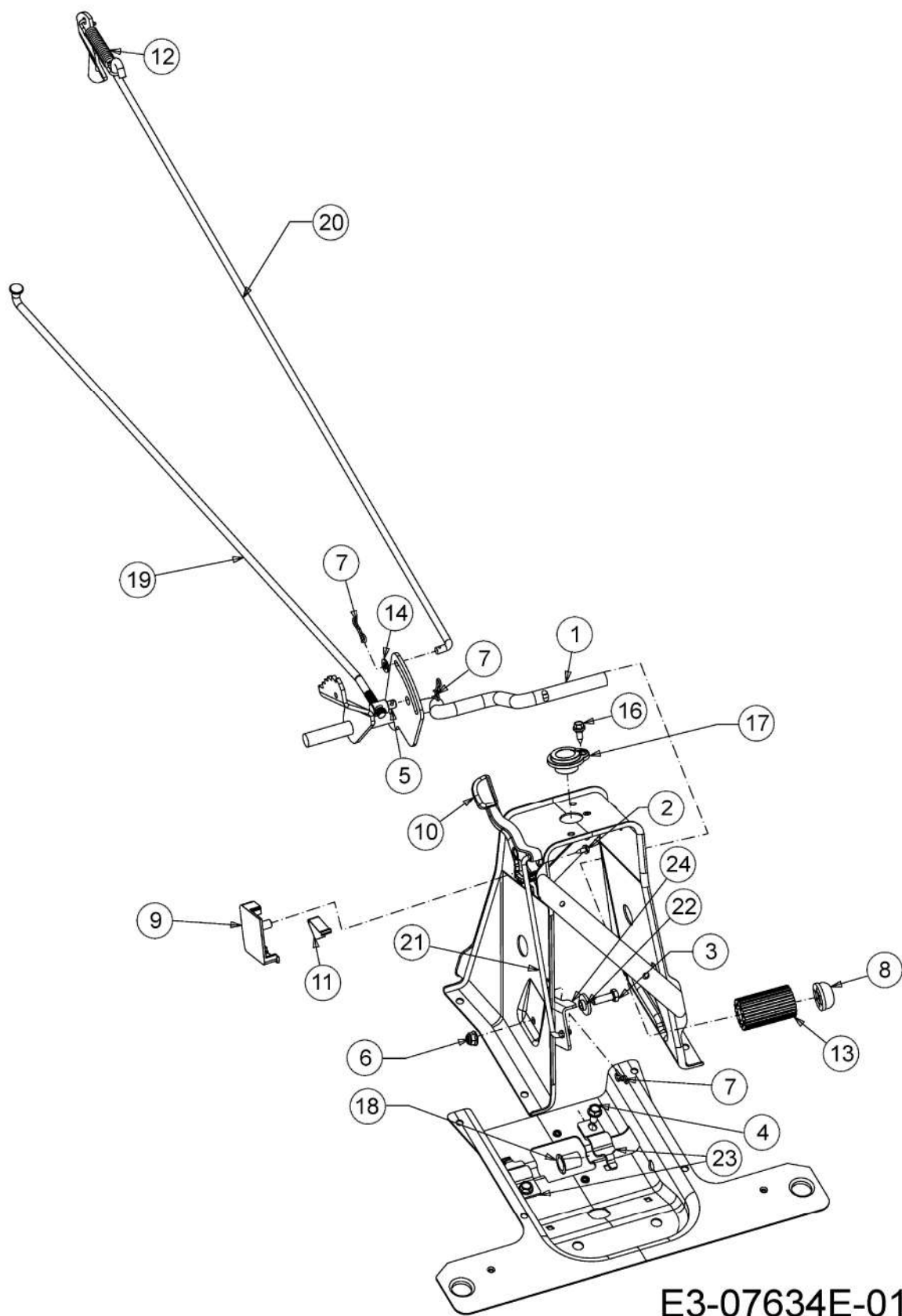

E3-07634E-01

## Tige de frein, Tige de commande, Pedale

Fig.	No. Pièces	Désignation	Numero de la norme	Nbr.
1	683-05017B-S	PEDALE DE FREIN	683-05017B-S	1
2	710-0224	VIS PARK:#10-16:0.500:HXINDWSH	FINISH:MTD SPEC-100016 TYPE 1	1
3	710-0376	VIS HEX.:5/16-18:1.00:GR5:STD	FINISH:MTD SPEC 701-01006	1
4	710-04484	VIS HEX. TT:5/16-18:.750:HXIND	FINISH:MTD SPEC-100016 TYPE 1	2
5	711-06103	FERRURE	FINISH:MTD SPEC-100015	1
6	712-04063	ECROU HEX. AVEC FLANC	FINISH:MTD SPEC-100015	1
7	714-04040	GOUPILLE	FINISH:ASTM F1941 FE/ZN 3AN	3
8	726-0214	BOUCHON	FINISH:SCHWARZ	1
9	731-08656B	COUVERCLE POIGNEE DE VITESSE	731-08656B	1
10	731-08743B	LEVIER SELECTEUR	731-08743B	1
11	732-04937	RESSORT DE VERROUILLAGE	FINISH:SPEC-100015	1
12	732-05464A	RESSORT	732-05464A	1
13	735-04279A	CAOUTCHOUC DE PEDALE	735-04279A	1
14	736-0264	RONDELLE: .330 x.630 x.0635	FINISH:SPEC-100015 936-0264	1
16	738-04184A	VIS A EPAULE:.368x.113:TT:1/4-	TT:FINISH MTD SPEC-100016	1
17	741-0356A	BAGUE DE VOLANT	FINISH:KUNSTSTOFF SCHWARZ	1
18	741-05135	BAGUE	FINISH:PLAIN	1
19	747-05506	TRINGLE	747-05506	1
20	747-06033A	TRINGLE DE FREIN	747-06033A	1
21	747-06449	TRINGLE SELECTION DE VITESSE	747-06449	1
22	748-0234	RONDELLE EPAULEE	FINISH:ROSTPREVENTION	1
23	783-05940	SUPPORT	FINISH:MTD SPEC-100015	2
24	783-08116C-S	SUPPORT	783-08116C-S	1



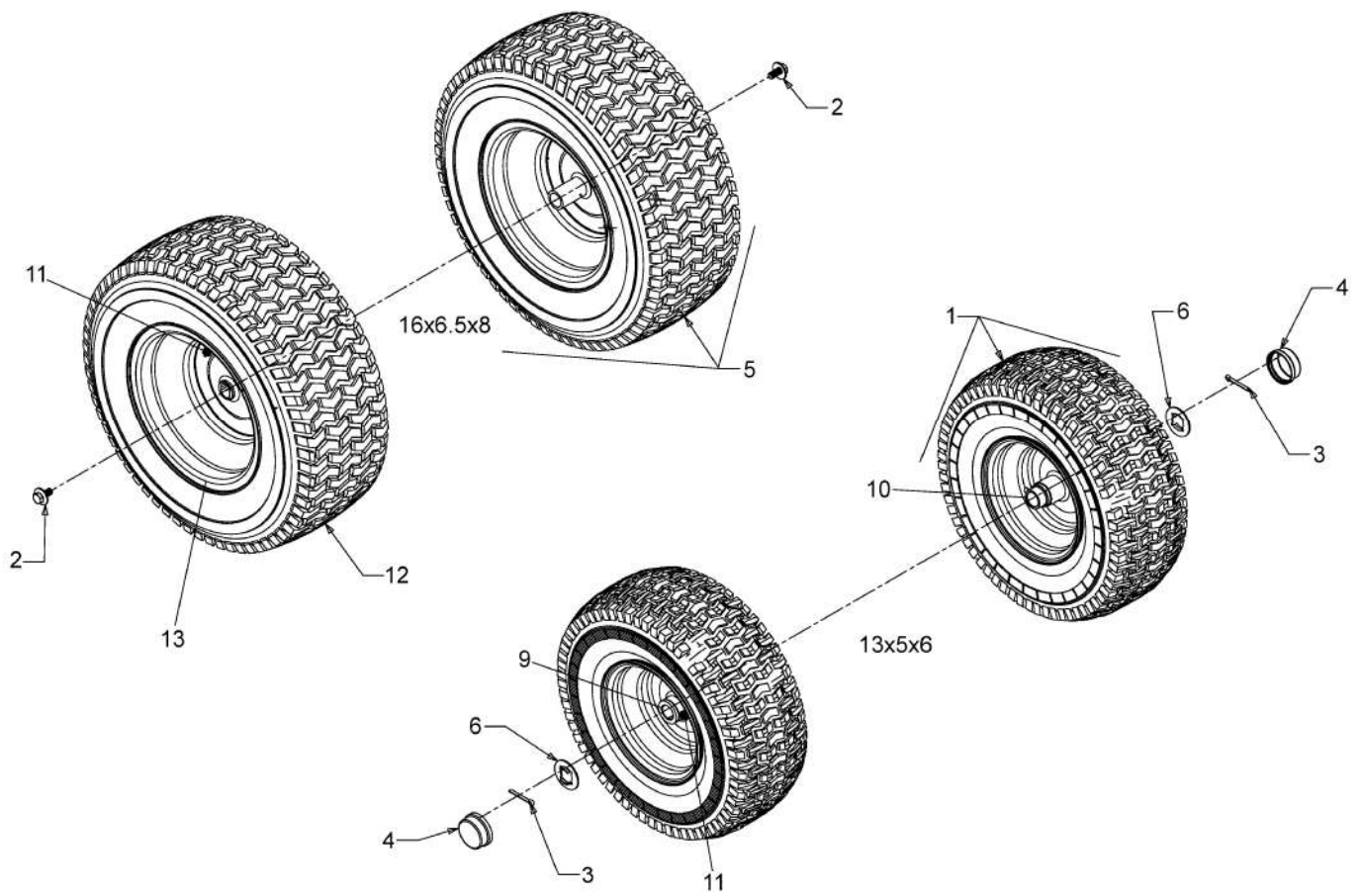

E3-07650C-01

## Roues 13x5x6; 16x6,5x8

Fig.	No. Pièces	Désignation	Numero de la norme	Nbr.
1	634-04726	ROUE 15X5X6	634-04726	2
2	710-05339A	VIS	FINISH:MTD STD SPEC-101617	2
3	714-0162	GOUPILLE FENDUE 5/32:1.25	FINISH:MTD SPEC-100015	2
4	731-0484A	ENJOLIVEUR DEVANT	KUNSTSTOFF SCHWARZ 931-0484A	2
5	734-0591	ROUE COMPL 16XXX6,50-8 ST	734-0591-0912	2
6	736-04228B	RONDELLE	SPECIAL:FINISH SPEC-701-100015	2
9	741-0516B	BAGUE DE ROUE .760x1.00x1.20	FINISH:SCHWARZ	2
10	741-0990B	BAGUE DE ROUE AVEC GRAISSEUR	m.SCHMIERNIPPEL:FINISH SCHWARZ	2
11	734-0255	VALVE:PNEU	TR 412-P / 32.6mm / 934-0255	4
12	734-04641	PNEU 16.00X6.50X8.00	SQ:SH:TURF SAVER	2
13	634-04174	JANTE 8.0x5.38 AVEC VALVE		2

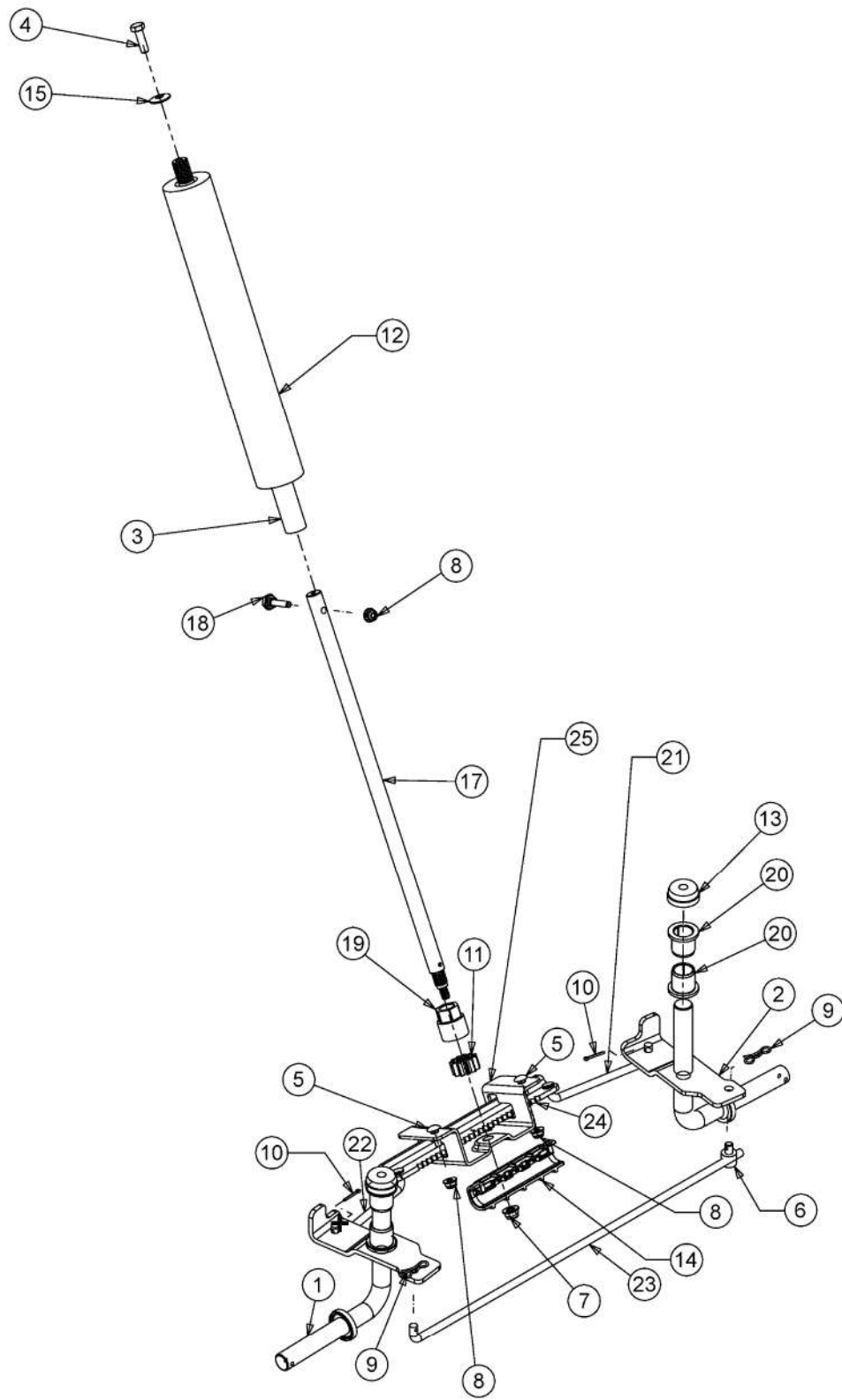

813-050349-07

# Systeme direction

Fig.	No. Pièces	Désignation	Numero de la norme	Nbr.
1	683-04726637	FUSEE DROITE	683-04726637	1
2	683-04727637	FUSEE GAUCHE	683-04727637	1
3	683-04763637	COLONNE DE DIRECTION	683-04763637	1
4	710-0643	VIS HEX.: 5/16-18:1.00:GR5	FINISH:MTD SPEC-100015	1
5	710-0703	VIS	FINISH:MTD SPEC-100015	2
6	711-04448	FERRURE	FINISH:ASTM F1941 FE/ZN 3AN	1
7	712-04063	ECROU HEX. AVEC FLANC	FINISH:MTD SPEC-100015	1
8	712-04064	ECROU HEXAGONAL	FINISH:SPEC-100015 912-04064	3
9	714-04040	GOUPILLE	FINISH:ASTM F1941 FE/ZN 3AN	2
10	714-0507	GOUPILLE FENDUE 3/32 X .750	FINISH:MTD SPEC-100015	2
11	717-1554	PIGNON DE DIRECTION	FINISH:GEÖLT	1
12	723-04095B	PROTECTION DE COLONNE	FINISH:SMOOTH BLACK	1
13	726-0341	CAPUCHON CLIPS	FINISH:SCHWARZ	2
14	731-13477B			1
15	736-0242	RONDELLE CONIQUE.340X.872X.060	FINISH:MTD SPEC-100016	1
17	738-04537B			1
18	738-05000	VIS EPAULEE	FINISH:MTD SPEC-100015	1
19	741-04542A	BAGUE	FINISH:PLAIN	1
20	741-0660A	BAGUE ESSIEU DE ROUE	FINISH:KUNSTSTOFF SCHWARZ	4
21	747-05514	TIGE DE DIRECTION GAUCHE	747-05514	1
22	747-05585	TIGE DE DIRECTION DROITE	747-05585	1
23	747-06638	TRINGLE DE DIRRECTION	747-06638	1
24	783-06988B			1
25	783-09629A			1

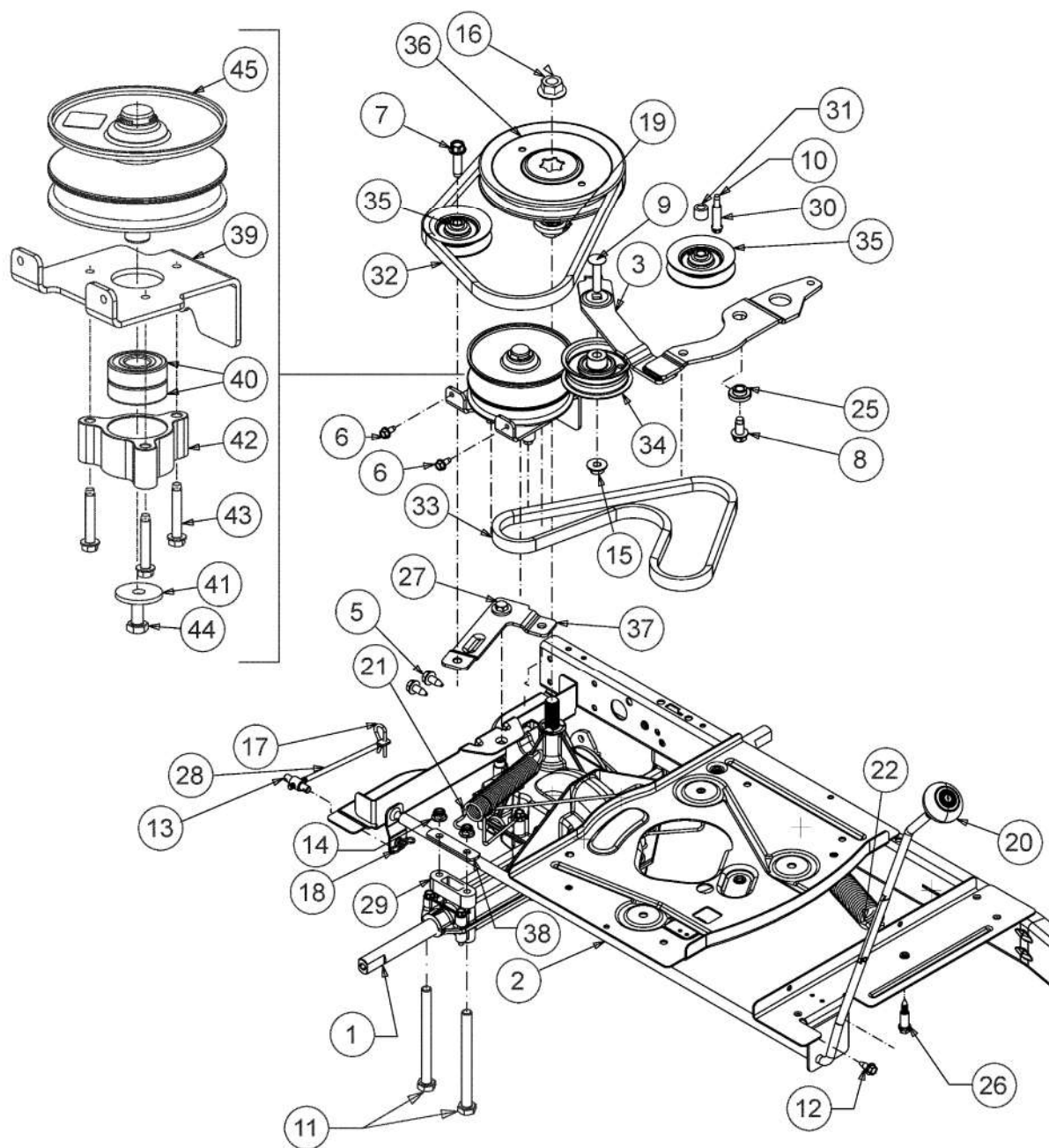

813-050138-36

# Entraînement de roulement

Fig.	No. Pièces	Désignation	Numero de la norme	Nbr.
1	618-09929	PONT COMPLET	618-09929	1
2	647-05114	LEVIER INVERSEUR	647-05114	1
3	683-04768A-S	SUPPORT POULIES	683-04768A-S	1
5	710-04484	VIS HEX. TT:5/16-18:.750:HXIND	FINISH:MTD SPEC-100016 TYPE 1	2
6	710-0599	VIS A SIX PANS CREUX	FINISH:MTD SPEC-101617	2
7	710-06016	VIS	FINISH:SPEC-100016 TYPE 1	1
8	710-0623	VIS PARK. HEX.:TT:3/8-16:0.750	FINISH:MTD SPEC-100016 TYPE 1	1
9	710-06234	VIS	FINISH:MTD SPEC-100015	1
10	710-1026	VIS HEX:TT:1/4-20:1.750	FINISH:MTD-SPEC-100016	1
11	710-1266	VIS HHCS:5/16-18:3.5:GR5:STD	FINISH:MTD SPEC-100015	4
12	710-1652	VIS HEX. TT:1/4-20:.625:HXINDW	FINISH:MTD-SPEC-100016 TYPE 1	1
13	711-06141	FERRURE	FINISH:MTD SPEC-100015	1
14	712-04063	ECROU HEX. AVEC FLANC	FINISH:MTD SPEC-100015	4
15	712-04217	ECROU	FINISH:MTD SPEC-100015	1
16	712-0700	ECROU HEXAGONAL	SPEC-100015+WAX 912-0700	1
17	714-0209	GOUPILLE FENDUE	FINISH:SPEC 701-01006 914-0209	1
18	714-04040	GOUPILLE	FINISH:ASTM F1941 FE/ZN 3AN	1
19	718-04407	MOYEU: POULIE:5/8 DENTELURE	VERZAHNUNG	1
20	720-04039	POMMEAU: LEVIER D'EMBRAYAGE	FINISH: SCHWARZ	1
21	732-05573A	RESSORT DE TENSION	732-05573A	1
22	732-07086	RESSORT DE TENSION	732-07086	1
25	738-0372B	RONDELLE EPAULEE	FINISH:GEÖLT	1
26	738-05016A	VIS EPAULEE	FINISH:SPEC-000087 (BLACK)	1
27	738-05019	VIS EPAULEE	FINISH MTD SPEC-100016	1
28	747-05593	TRINGLE	747-05593	1
29	748-0334	ENTRETOISE	FINISH:GEÖLT	2
30	750-04456	ENTRETOISE	FINISH:MTD SPEC-100015	1
31	750-05563	ENTRETOISE	FINISH:MTD SPEC-100015	1
32	754-0241A	COURROIE VARIATEUR/BOITE	FINISH:SIEHE ZG. 954-0241A	1
33	754-04331	COURROIE	FINISH: SIEHE CHART	1
34	756-04224	POULIE TENDEUR	BLK ECOAT,PAINT OR SPEC-100015	1
35	756-04325	POULIE TENDEUR	FINISH:SCHWARZ LACKIERT	2
36	756-04464	POULIE DE PONT	FINISH:SIEHE ZG.	1
37	783-07248A	SUPPORT	783-07248A	1
38	783-08131637	SUPPORT DE PONT	783-08131637	2
39	783-08210A-S	SUPPORT VARIATEUR	783-08210A-S	1
40	741-0124A	ROULEMENT A BILLE	FINISH:	2
41	736-0343	RONDELLE .330 ID X 1.25 X .12	FINISH:MTD 701-100015	1
42	718-04261	CAGE DE ROULEMENT	FINISH:ROSTSCHUTZ SIEHE ZG.	1
43	710-0778	VIS HEX. TT:1/4-20:1.500	FINISH:MTD SPEC-100016 TYPE 1	3
44	710-0627	VIS HEX. 5/16-24:.750 GR5:LOCK	FINISH:MTD SPEC-100015	1
45	656-05011	POULIE VARIATEUR	FINISH:SEE DRW	1

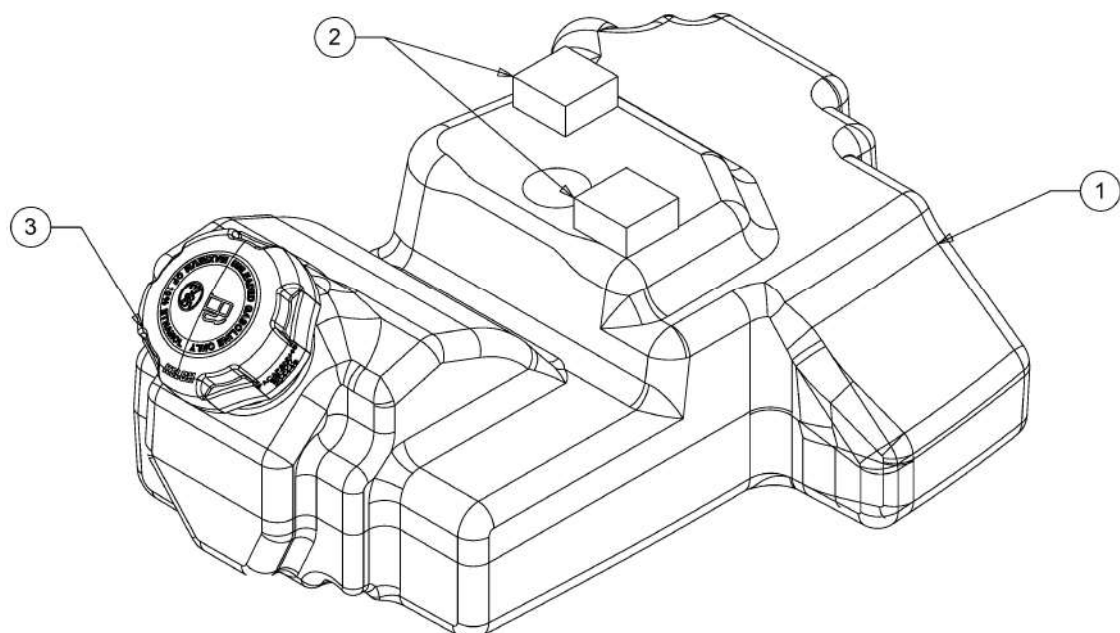

813-050163-06

# Réservoir

Fig.	No. Pièces	Désignation	Numero de la norme	Nbr.
1	651-04385C			1
2	722-3020		FINISH:SIEHE ZG.	2
3	751-12179C	BOUCHON DE RESERVOIR ESSENCE	FINISH:SIEHE ZG.	1



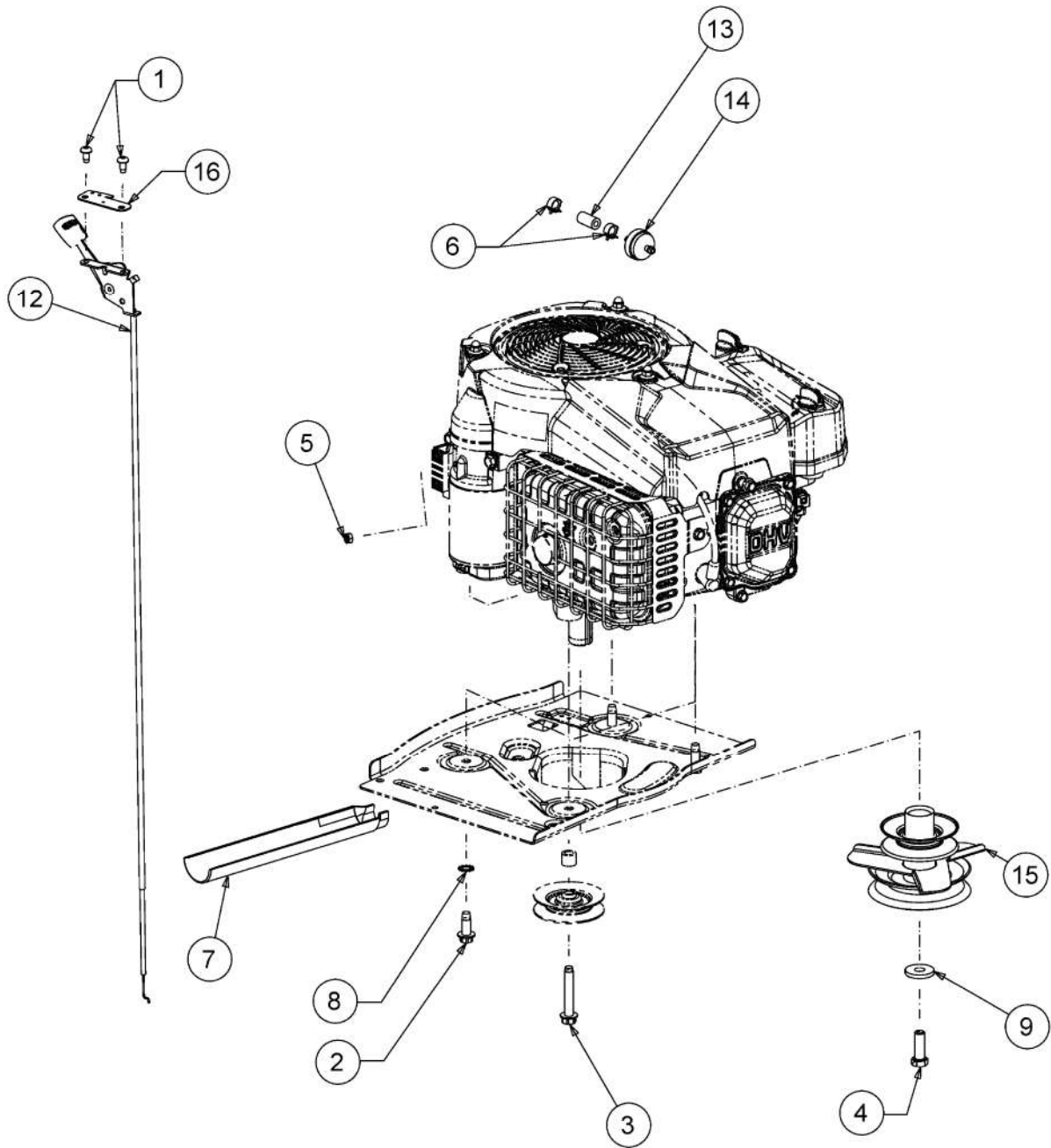

813-050862-06

## Commande de choke et gaz, Poulie moteur, Accessoires moteur

Fig.	No. Pièces	Désignation	Numero de la norme	Nbr.
1	710-04483	VIS:TT:1/4-20:.500:TRUSTRXI	FINISH:GELB SPEC-701-01002	2
2	710-04683C	VIS	FINISH:SIEHE ZG.	3
3	710-05446	VIS	FINISH:MTD SPEC-100016 TYPE 1	1
4	710-06067	VIS	FINISH:MTD SPEC-100015	1
5	712-0691	ECROU HEXAGONAL	MTD SPEC-100015 24.1426.14	1
6	726-0205	COLLIER DE SERRAGE DE BOYAU	FINISH:PHOS UND GELB LACKIERT	2
7	731-1682A	DRAINAGE HUILE	FINISH:KUNSTSTOFF SCHWARZ	1
8	736-0148	RONDELLE	FINISH:MTD SPEC-100016	1
9	736-0322	RONDELLE .450 X 1.250 X .164	FINISH:SPEC-100016 936-0322	1
12	746-05049A	CABLE GAZ	MIT BEDIENUNGSHEBEL	1
13	751-10349-54	TUYAU ESSENCE 54"	751-10349-54	12
14	751-3013	FILTRE ESSENCE	COLOR:RED 951-3013	1
15	756-06043	POULIE MOTEUR	756-06043	1
16	783-12769	COMMANDE ACCELERATEUR	783-12769	1

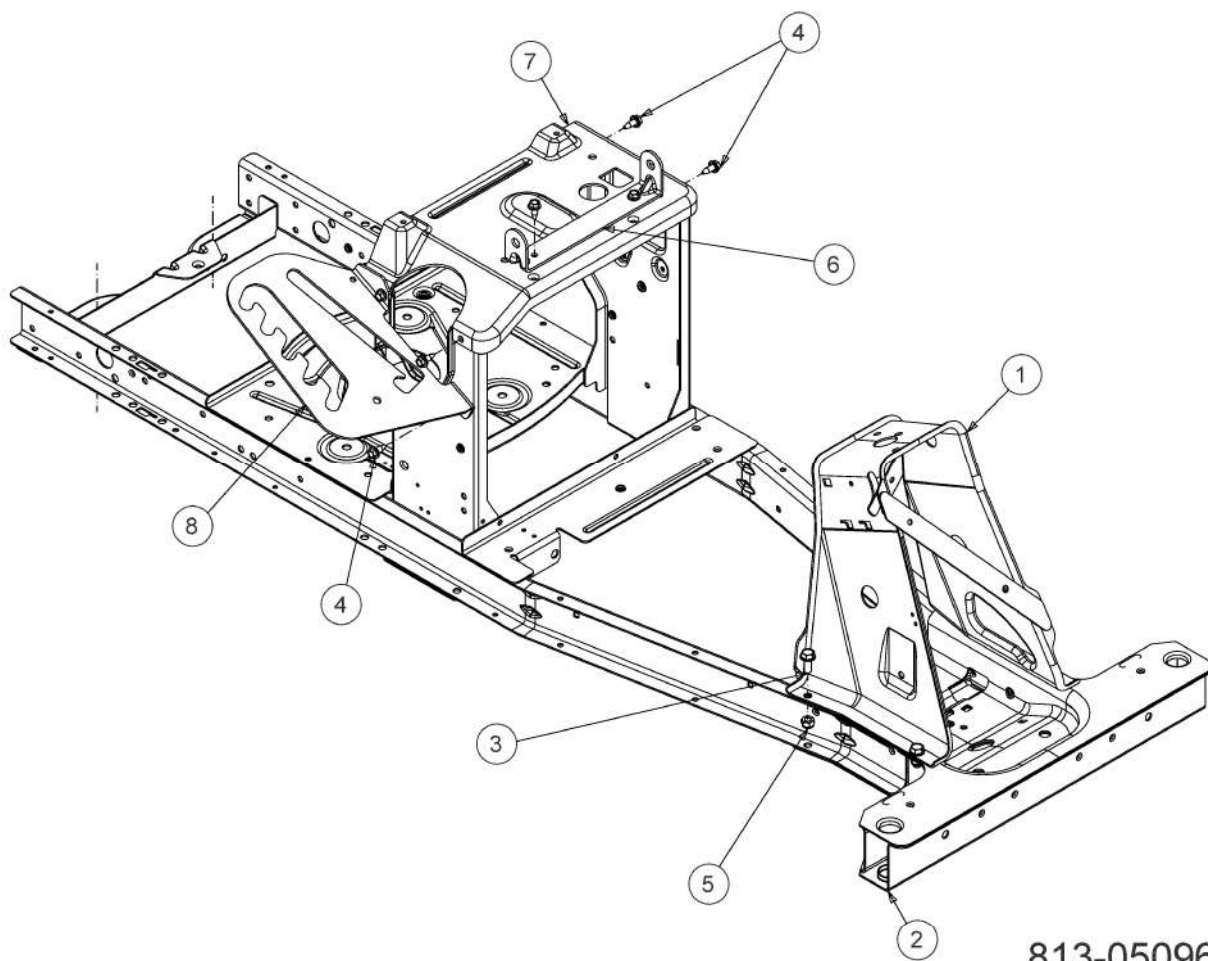

813-050962-01

## Châssis

Fig.	No. Pièces	Désignation	Numero de la norme	Nbr.
1	683-05167637	SOCLE DE COLONNE	683-05167637	1
2	683-05189C-S			1
3	710-06194	VIS	710-06194	4
4	710-1652	VIS HEX. TT:1/4-20:.625:HXINDW	FINISH:MTD-SPEC-100016 TYPE 1	7
5	712-0429	ECROU	FINISH:SPEC-100015	4
6	783-07168637	SUPPORT	783-07168637 *	1
7	783-08197	SUPPORT SIEGE	783-08197	1
8	783-08260637	PLAQUE SELECTEUR HAUTEUR DE	783-08260637	1

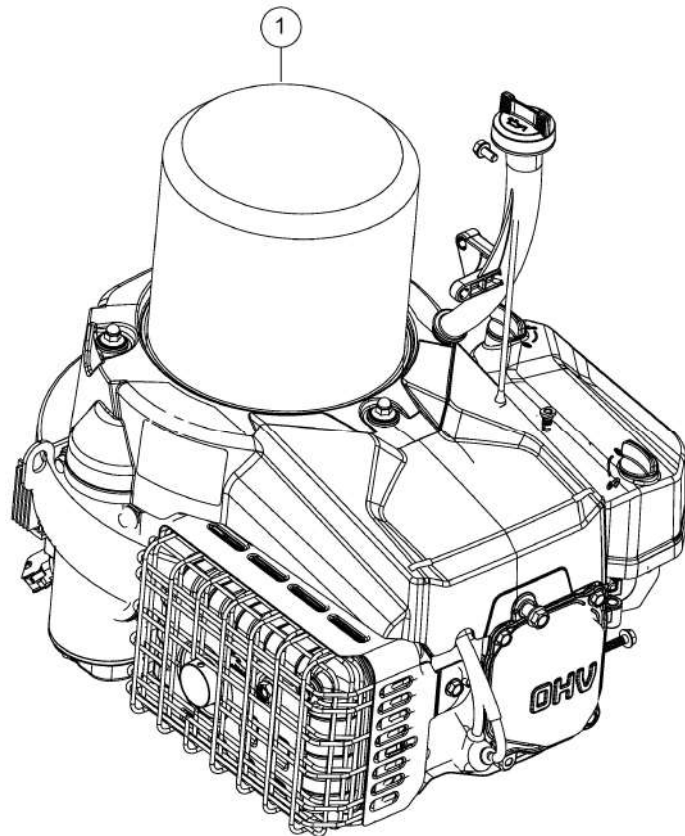

E3-08294M-01

# Moteur

Fig.	No. Pièces	Désignation	Numero de la norme	Nbr.
1	752Z7T84JHA	MOTEUR COMPLET	752Z7T84JHA	1

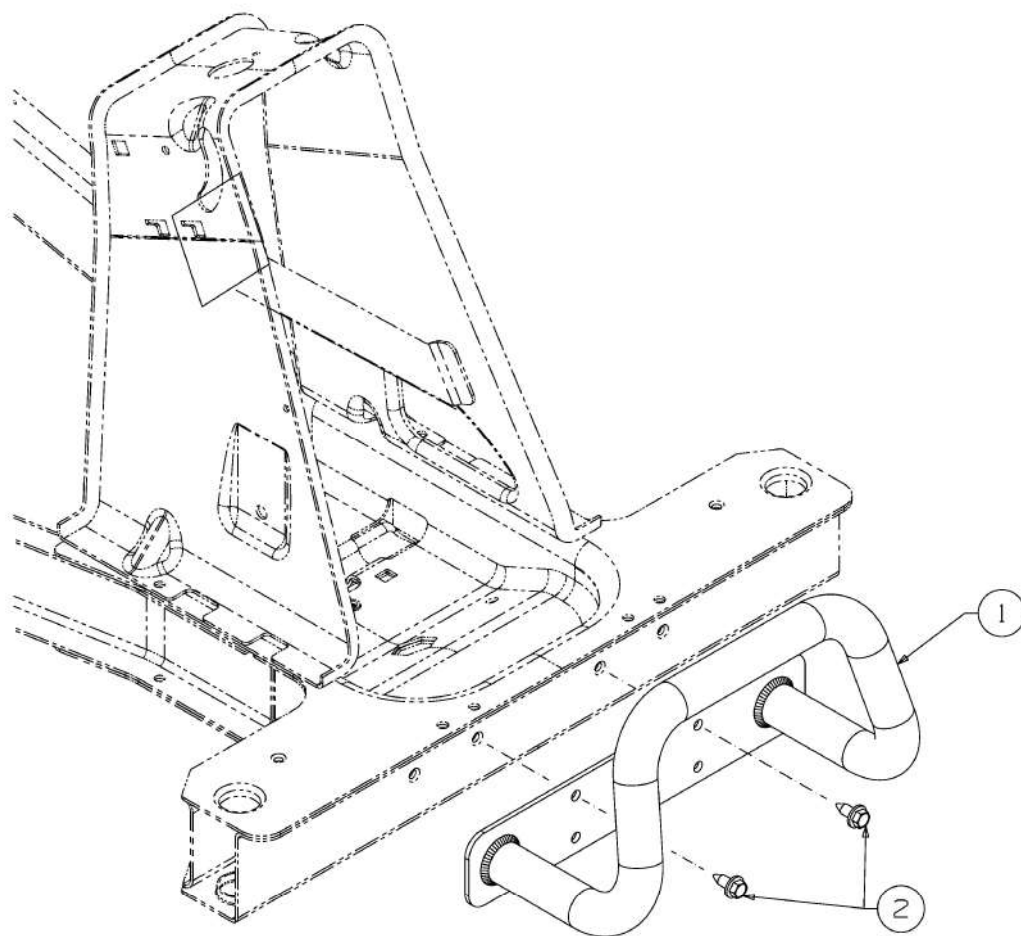

E3-07649A-01

# Pare-chocs

Fig.	No. Pièces	Désignation	Numero de la norme	Nbr.
1	683-04767637	PARE CHOCS	683-04767637	1
2	710-1652	VIS HEX. TT:1/4-20:.625:HXINDW	FINISH:MTD-SPEC-100016 TYPE 1	2



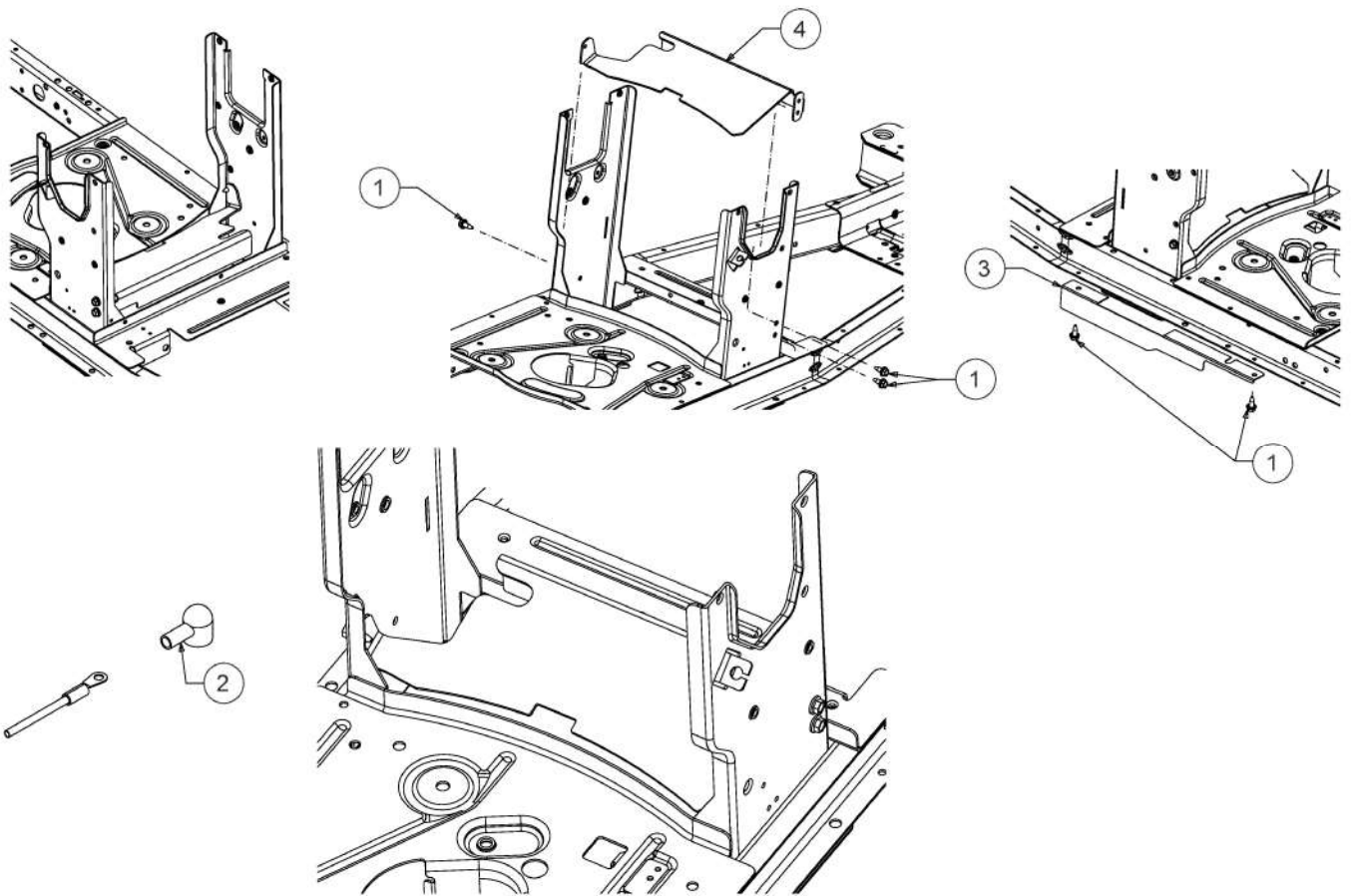

E3-07654D-01

## couverture

Fig.	No. Pièces	Désignation	Numero de la norme	Nbr.
1	710-1652	VIS HEX. TT:1/4-20:.625:HXINDW	FINISH:MTD-SPEC-100016 TYPE 1	1
2	725-3237	COUVERCLE POLE / ROUGE	BATTERIE FINISH:ROT	1
3	783-08208637	PROTECTION DE COURROIE	783-08208637	1
4	783-11048		783-11048	5

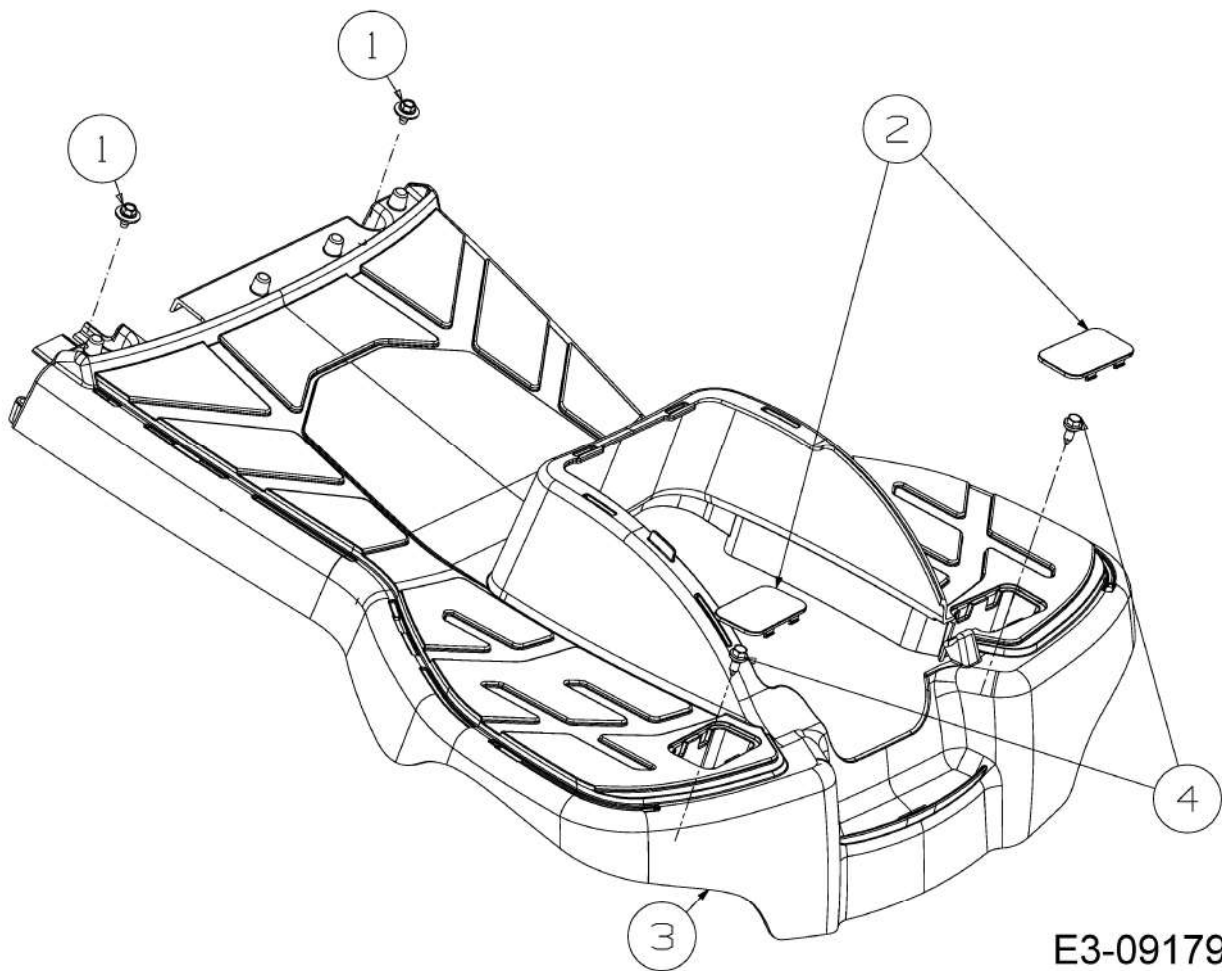

E3-09179B-01

# Marchepied

Fig.	No. Pièces	Désignation	Numero de la norme	Nbr.
1	710-05073	VIS 1/4-20X.50	710-05073	2
2	731-08753B	BOUCHON A CLIPS	731-08753B	2
3	731-11111	PLATE FORME	731-11111	1
4	738-04184A	VIS A EPAULE:.368x.113:TT:1/4-	TT:FINISH MTD SPEC-100016	2

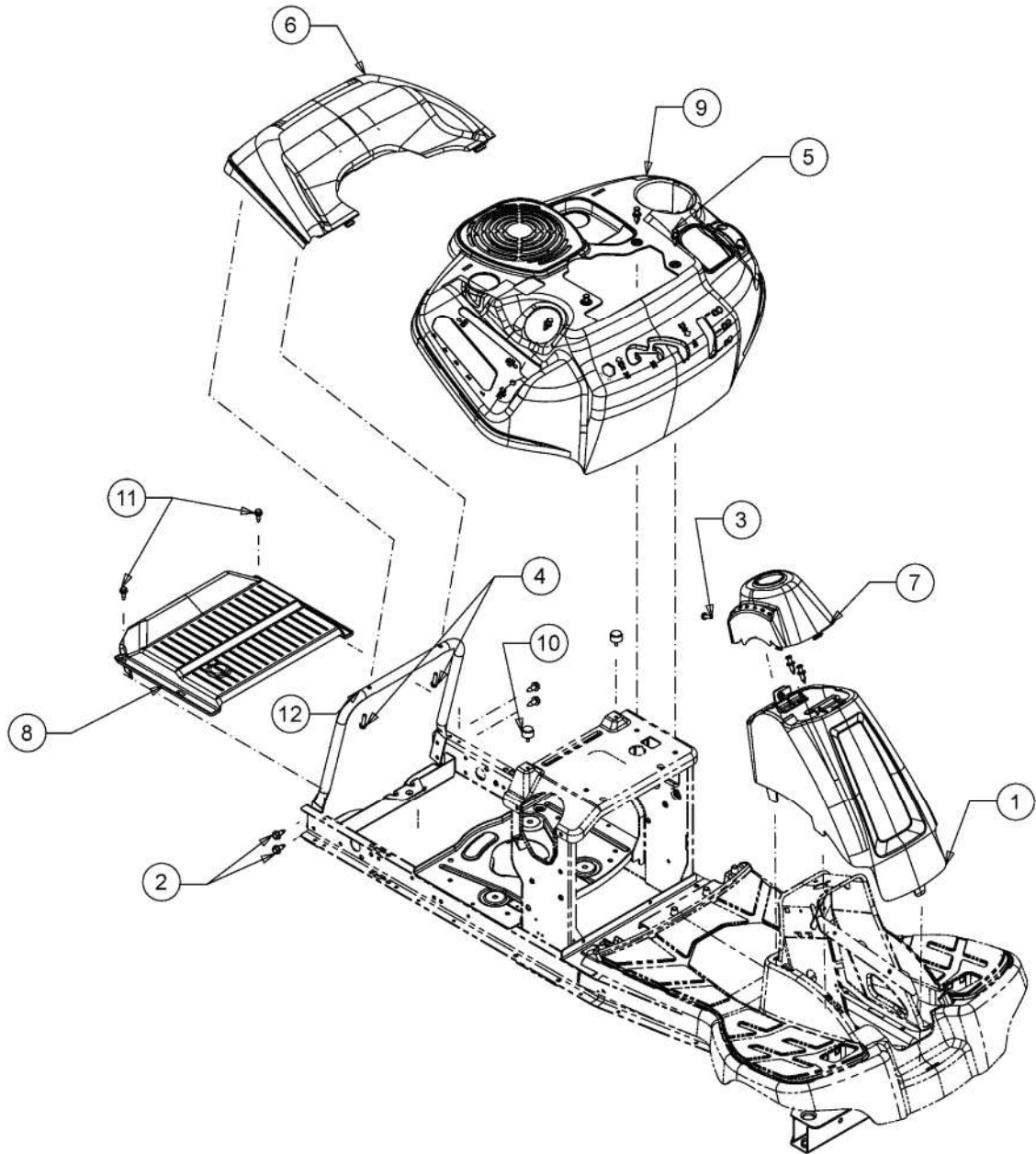

813-051024-00

# Habillages

Fig.	No. Pièces	Désignation	Numero de la norme	Nbr.
1	631-05038	CACHE DE COLONNE INFERIEUR	631-05038	1
2	710-04484	VIS HEX. TT:5/16-18:.750:HXIND	FINISH:MTD SPEC-100016 TYPE 1	4
3	710-0924	VIS EN Tête PLATE 1/4-20X;.75"	FINISH:MTD STD 701-01000	1
4	710-1241	VIS	FINISH:SPEC-100016 TYPE 1	2
5	728-0199	RIVET PLASTIQUE	KUNSTSTOFF FINISH:SCHWARZ	6
6	731-08620A	COUVERCLE ARRIERE	731-08620A	1
7	731-09382	CACHE DE COLONNE SUPERIEUR	731-09382	1
8	731-12695		731-12695	1
9	731-26466	CARTER DE COMMANDE	731-26466	1
10	735-05006	TAMPON DE SIEGE	FINISH:BLACK	2
11	738-04184A	VIS A EPAULE:.368x.113:TT:1/4-	TT:FINISH MTD SPEC-100016	2
12	749-04932637	ARMATURE DE COUVERCLE ARRIERE	749-04932637	1

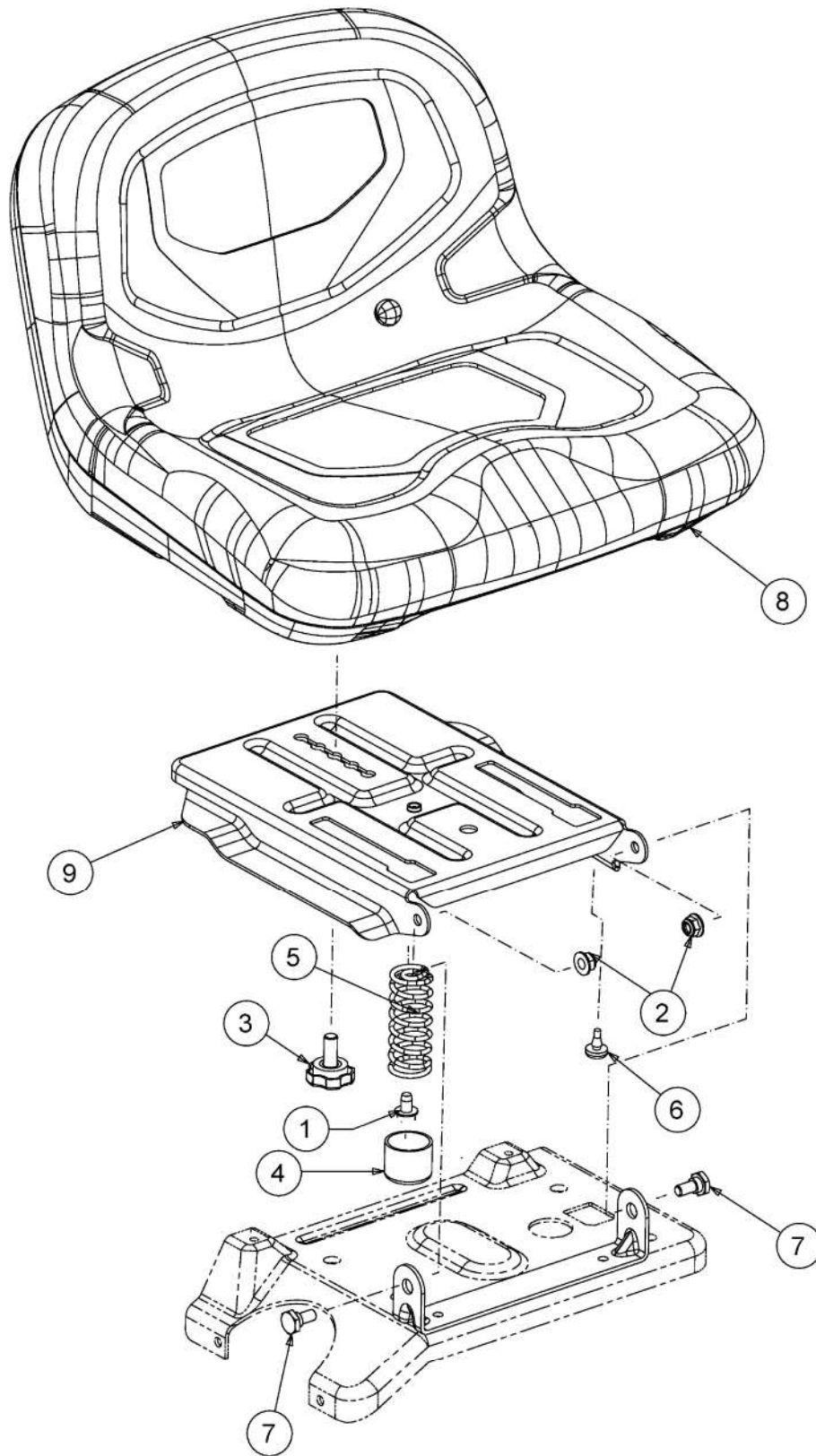

E3-10199C-01

## Siège, Support de siège

Fig.	No. Pièces	Désignation	Numero de la norme	Nbr.
1	710-0607	VIS HEX.TT5/16-18.:500HXINDWSh	FINISH:MTD SPEC-100016 TYPE 1	1
2	712-04063	ECROU HEX. AVEC FLANC	FINISH:MTD SPEC-100015	2
3	720-04009A	MOLETTE DE SIEGE	FINISH:SCHWARZ *	1
4	720-05005	PROTECTION DE RESSORT	720-05005	1
5	732-04905	RESSORT DE SIEGE	FINISH:SPEC-100015	1
6	735-0199A	BOUCHON EN CAOUTCH.:.62ODx.22	FINISH:SCHWARZ 935-0199A	1
7	738-0140	VIS A EP.:.435 x.178-5/16 x.56	FINISH:MTD SPEC-100015	2
8	757-05229	SIEGE	FARBE:SCHWARZ	1
9	783-07213A-S	SUPPORT DE SIEGE	783-07213A-S	1



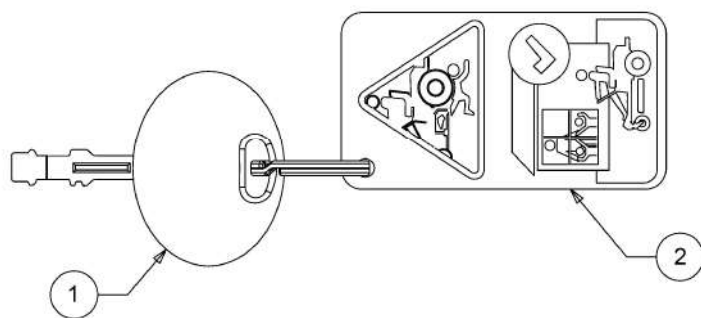

E3-10900A-01

# Clé

Fig.	No. Pièces	Désignation	Numero de la norme	Nbr.
1	725-1745A	CLE UNIVERSEL	FINISH:	1
2	731-19013			1

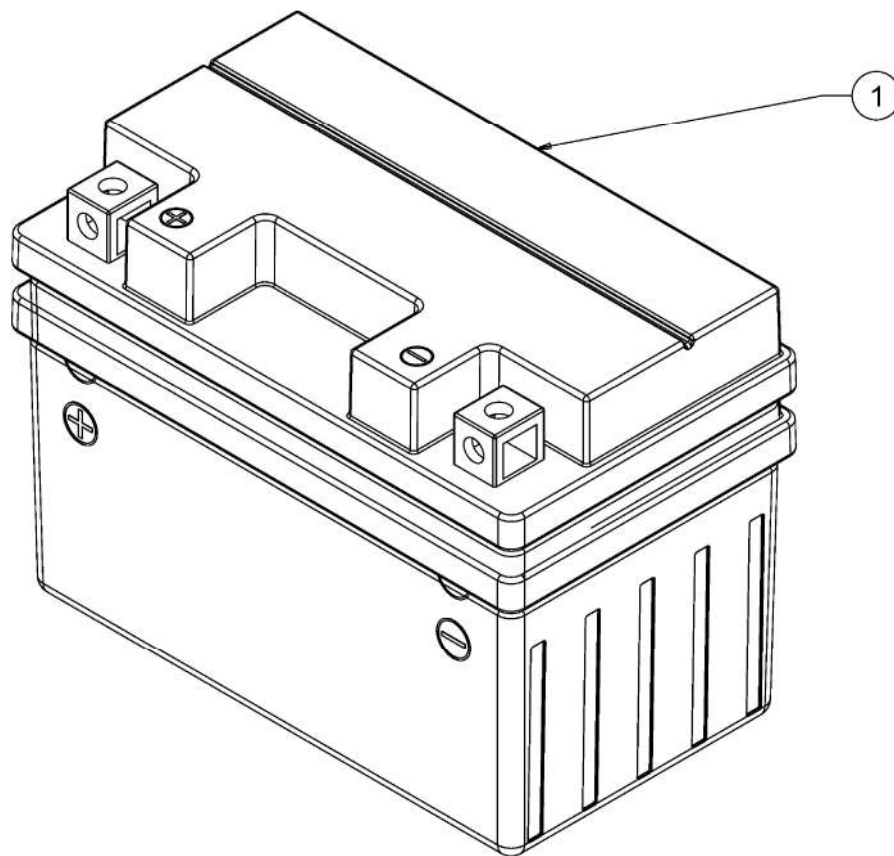

E3-02343G-01

# Batterie

Fig.	No. Pièces	Désignation	Numero de la norme	Nbr.
1	725-17136	BATTERIE AGM 7AH	725-17136	1

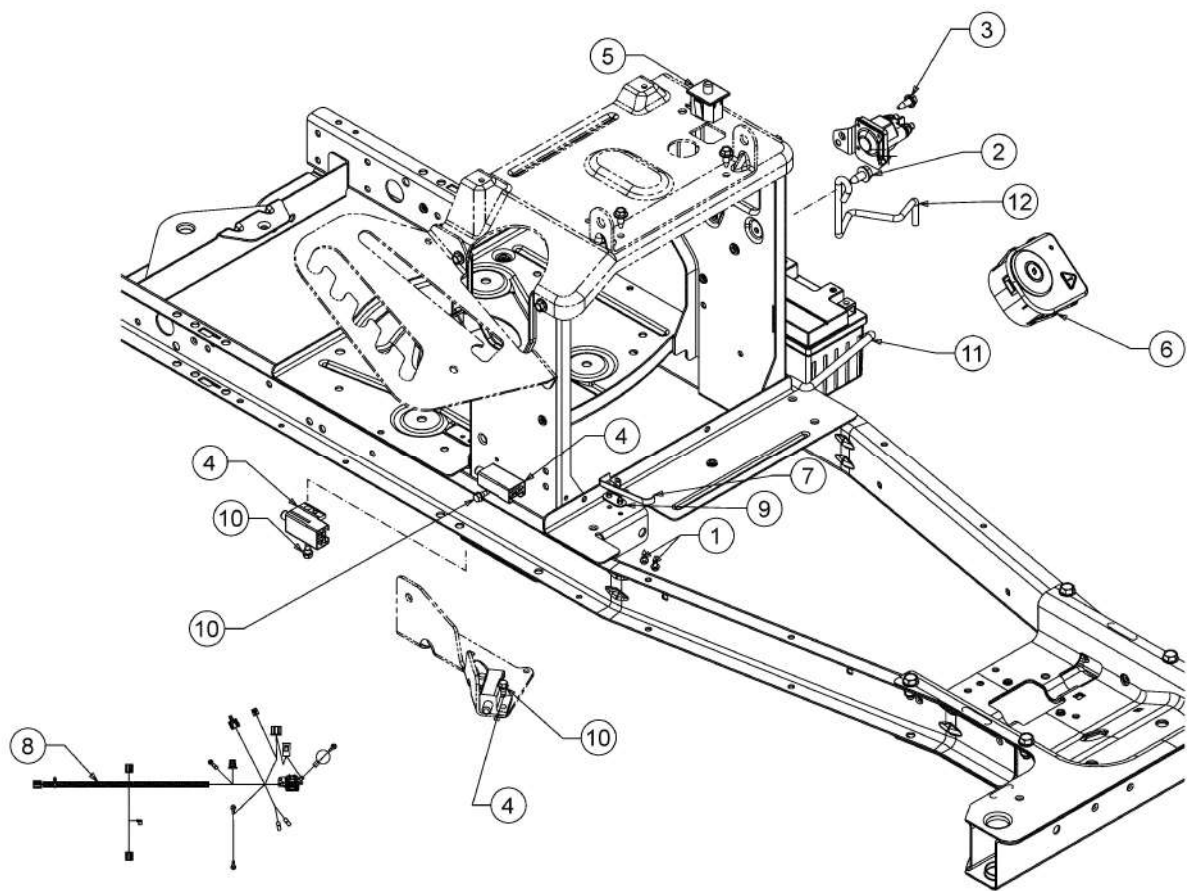

813-051011-00

## Assortiment électrique

Fig.	No. Pièces	Désignation	Numero de la norme	Nbr.
1	710-0227	VIS	FINISH:MTD SPEC-100016 TYPE 1	2
2	710-04484	VIS HEX. TT:5/16-18:.750:HXIND	FINISH:MTD SPEC-100016 TYPE 1	1
3	710-1652	VIS HEX. TT:1/4-20:.625:HXINDW	FINISH:MTD-SPEC-100016 TYPE 1	1
4	725-04363	SECURITE EMBRAYAGE	FINISH:SIEHE ZG.	3
5	725-05013	SECURITE DE SIEGE	FINISH:GRAU	1
6	725-06119C		FINISH:	1
7	725-1643	CONTACTEUR SECURITE	LANG:FINISH:SPEC-100016	1
8	725-17170			1
9	726-0320	PLAQUE D'ISOLATION	FINISH:NATUR ODER SCHWARZ	1
10	738-04237A	AXE EPAULE	FINISH:MTD SPEC-100016	3
11	747-11586	SUPPORT BATTERIE	747-11586	1
12	747-11587	TRINGLE SUPPORT BATTERIE	747-11587	1