

# PONY 92T-R

13AB77BE609

2023

Table-No.:	Description
E3-07448B-01	Palier 618-0409C
E3-01665C-01	Palier 618-0324D / 918-0324D
813-070059-08	"Couvercle de protection courroie plateau de coupe E (36"/92cm)"
813-070013-05	Poulie moteur
813-070006-38	Plateau de coupe 92cm
E3-03897D-01	Relevage plateau de coupe
813-070004-18	Dispositif de rÚception de l'herbe
E3-11406A-01	TuyPre nettoyage
813-060662-11	Axe avant
813-062012-00	Enjoliveur
813-061032-10	Frein d'arrÚt
813-500112-04OG	Roues, fusÚes d'essieu
813-060293-21	SystPme direction
813-010305-00	Volant
E3-11416A-01	Moteur
813-070789-00	Accessoires moteur
813-070005-28A	Entra_nement de roulement, Pedale
813-070005-28B	Levier de commande
813-070005-28C	Bo_te de vitesse 1
813-070005-28D	Bo_te de vitesse 2
813-070005-28E	Frein
813-070030-23	Entra_nement de roulement, Variateur
813-061066-06	RÚervoir
813-070010-11R	Jupe
813-070082-18	ChÓssis
813-062321-06	Capot de moteur
E3-02721A-01	Marchepied garniture
813-070788-05	RÚglage de siPge
813-062983-00	SiPge
E3-11414A-01	Cable de gaz
813-061151-11	Tableau de bord
731-08542C-02	Tableau de bord piPce supÚrieure
813-070819-00	Assortiment Úlectrique
731-12705A-01	Conduit air
E3-06862B-01	Couvercle de protection du tableau de bord
E3-04007A-01	Contacteur
E3-10900A-01	CIÚ
813-064058-02	Batterie

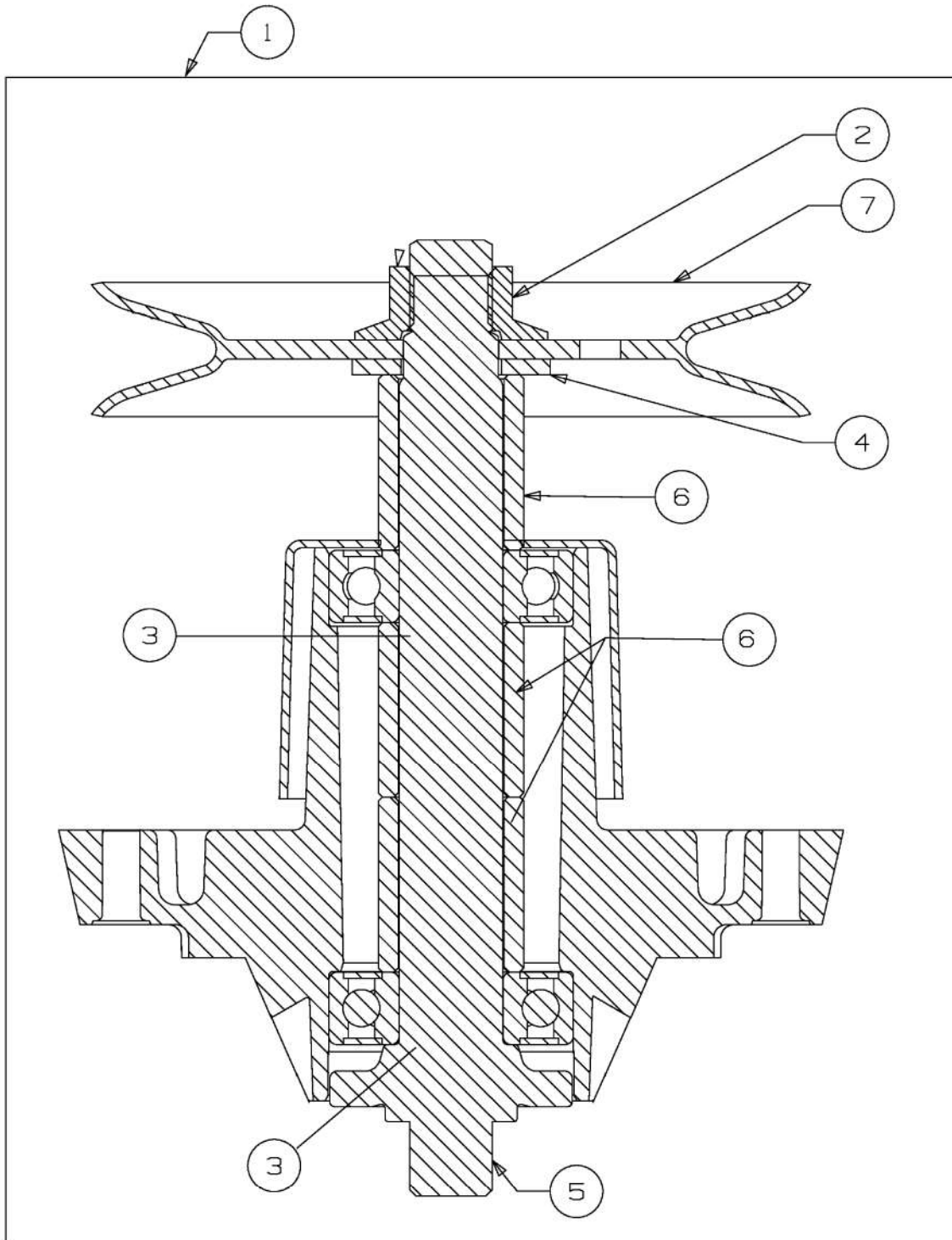

E3-07448B-01

# Palier 618-0409C

Fig.	No. Pièces	Désignation	Numero de la norme	Nbr.
1	618-0409C	PALIER DE LAME COMPLET		1
2	712-0417A	_CROU HEX. AV. FLANC: 5/8-18	FINISH:MTD STD 701-01000	1
3	741-0919A	ROULEMENT A BILLES	FINISH:	2
4	736-0315	RONDELLE FL	FINISH:STD SPEC-100015	1
5	738-1128	AXE DE PALIER DE LAMES:6.58"	FINISH:GEILT	1
6	750-1000	ENTRETOISE:.80x1.10x1.330	FINISH:GEILT	3
7	756-04216	POULIE DE PALIER DE LAME G	FINISH:SPEC-100015	1

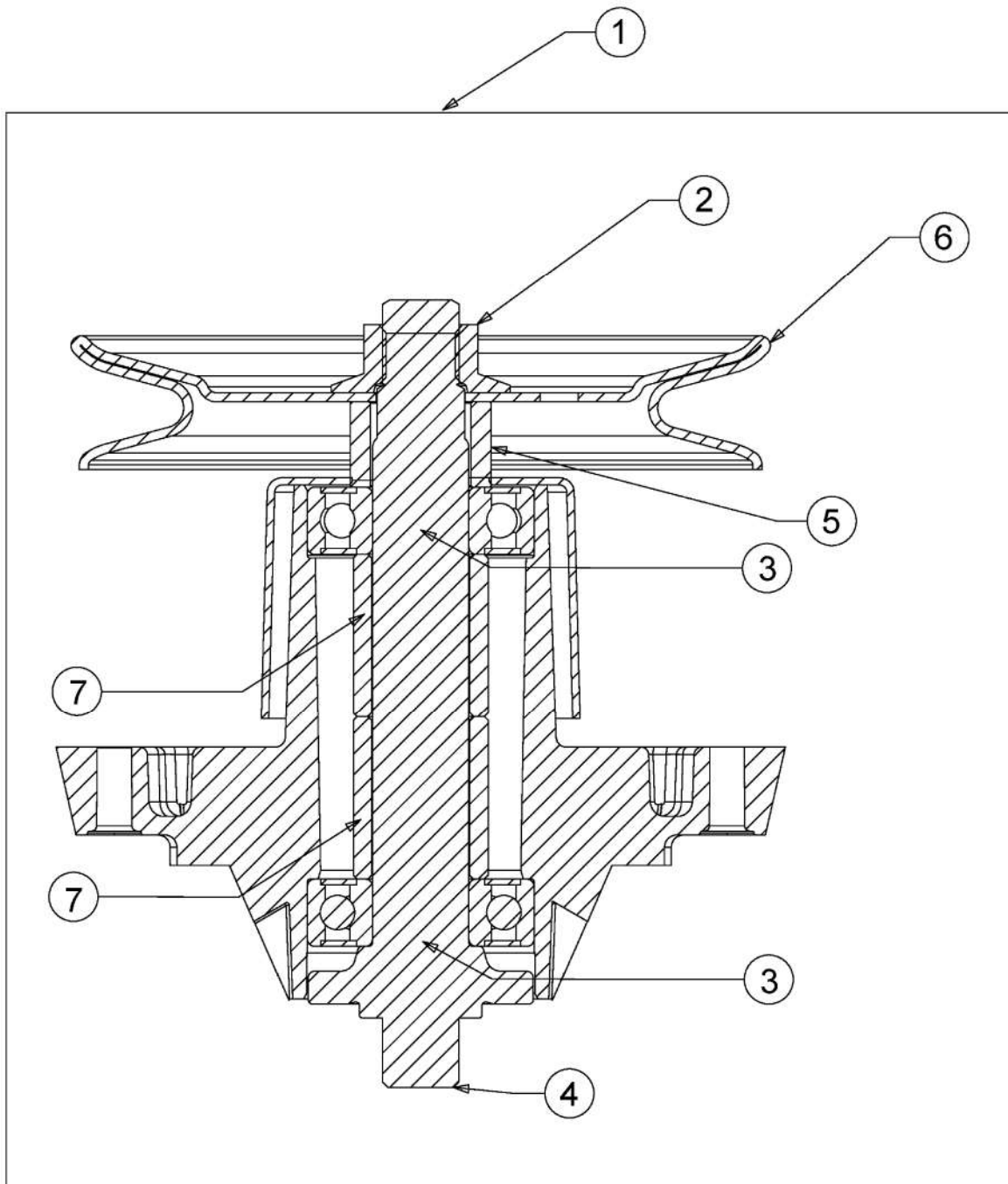

E3-01665C-01

# Palier 618-0324D / 918-0324D

Fig.	No. Pièces	Désignation	Numero de la norme	Nbr.
1	918-0324D	PALIER DE LAME CPL.D :	RIEMENSCHLEIBE 5.75 DIA	1
2	712-0417A	_CROU HEX. AV. FLANC: 5/8-18	FINISH:MTD STD 701-01000	1
3	741-0919A	ROULEMENT A BILLES	FINISH:	2
4	738-1010A	AXE DE PALIER 5.75 LG	FINISH:GEÍLT 618-0324A	1
5	748-04302	ENTRETOISE	FINISH:GEÍLT	1
6	756-1188	POULIE DE COURROIE TRAPEZ.	SPEC-100015 or AUTOPHORETIC C.	1
7	750-1000	ENTRETOISE:.80x1.10x1.330	FINISH:GEÍLT	2

"Couvercle de protection courroie plateau de coupe E (36"/92cm)"

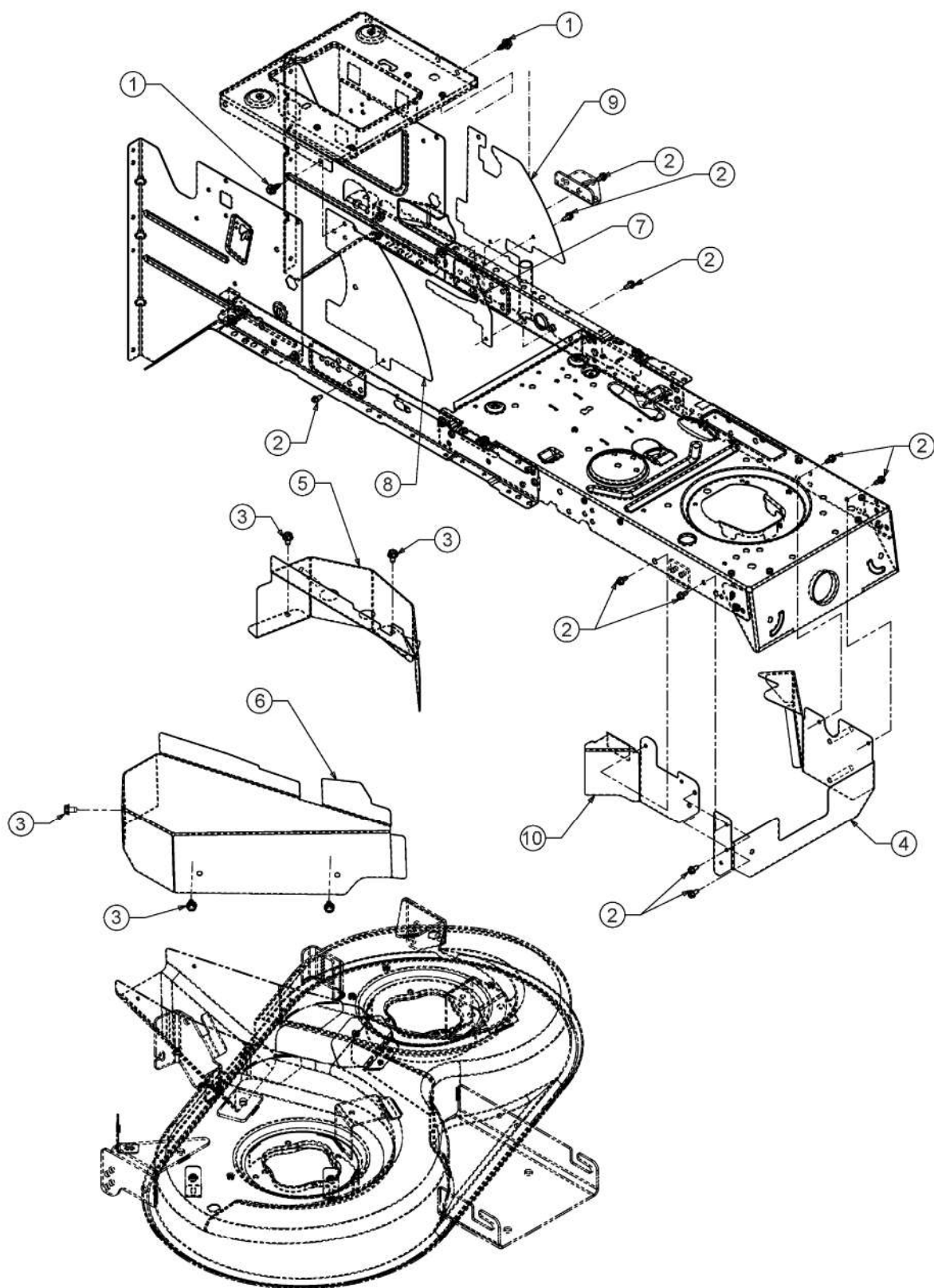

813-070059-08

## "Couvercle de protection courroie plateau de coupe E (36"/92cm)"

Fig.	No. Pièces	Désignation	Numero de la norme	Nbr.
1	710-04484	VIS HEX. TT:5/16-18.:750:HXIND	FINISH:MTD SPEC-100016 TYPE 1	2
2	710-0599	VIS A SIX PANS CREUX	FINISH:MTD SPEC-101617	10
3	710-0607	VIS HEX.TT5/16-18.:500HXINDWSh	FINISH:MTD SPEC-100016 TYPE 1	5
4	783-05998		FINISH:LACKIERT MTD QUALIT-T	1
5	783-06000		FINISH:LACKIERT MTD QUALIT-T	1
6	783-06001A	FINISH:LACKIERT MTD QUALIT-T	FINISH:LACKIERT MTD QUALIT-T	1
7	783-06084		FINISH:LACKIERT MTD QUALIT-T	1
8	783-06676	PROTECTION DROITE	FINISH:LACKIERT MTD QUALIT-T	1
9	783-09678637	PROTECTION ARRIERE GAUCHE	FINISH:LACKIERT MTD QUALIT-T	1
10	783-10528-RG	PROTECTION AVANT DROITE	GUTBROD ROT	1
10	783-10528637	PROTECTION AVANT DROITE	SCHWARZ	1
10	783-10528638	PROTECTION AVANT DROITE	MTD ROT	1



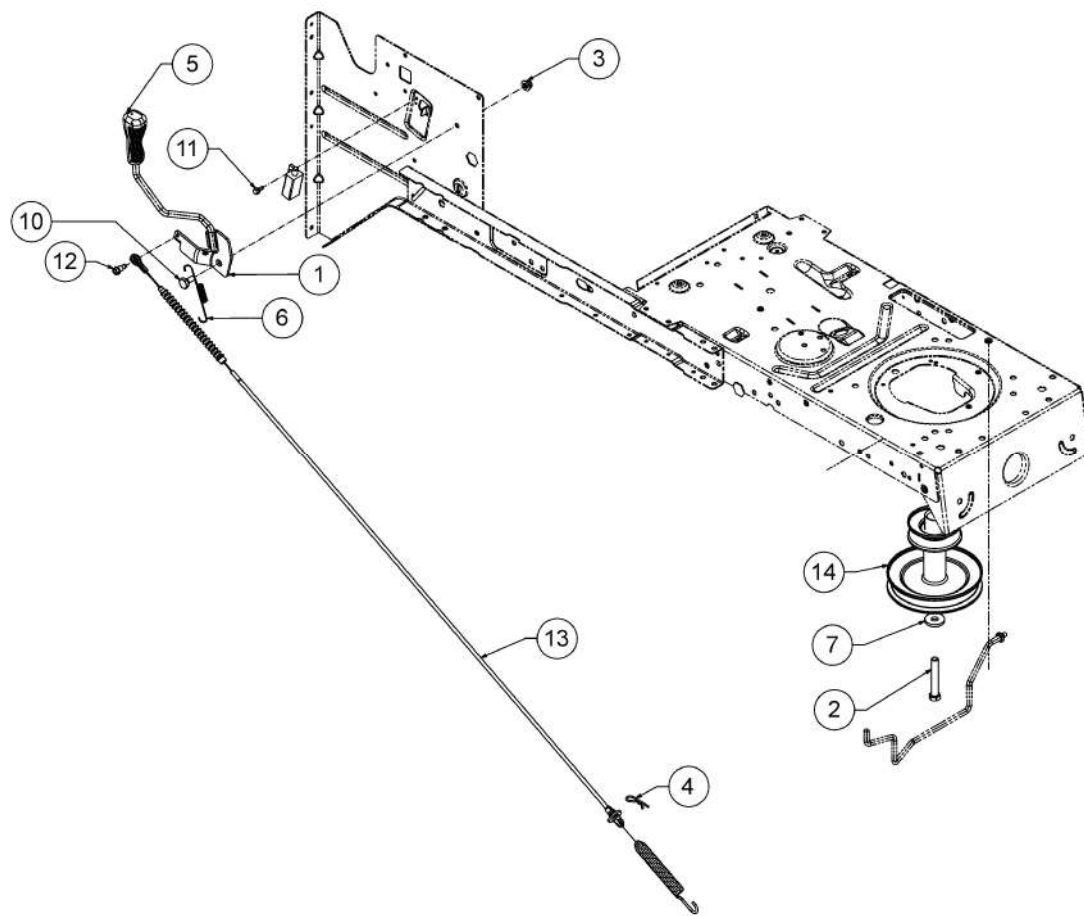

813-070013-05

## Poulie moteur

Fig.	No. Pièces	Désignation	Numero de la norme	Nbr.
1	647-04239B			1
2	710-04377	VIS A SIX PANS CREUX	FINISH:MTD SPEC-100015	1
3	712-04063	ECROU HEX. AVEC FLANC	FINISH:MTD SPEC-100015	1
4	714-0145	GOUPILLE	FINISH:SPEC-701-01006	1
5	720-04049A	POIGNEE PLASTIQUE	FINISH:SCHWARZ	1
6	732-05376	RESSORT LEVIER PTO	FINISH:MTD SPEC-701-01006	1
7	736-0322	RONDELLE .450 X 1.250 X .164	FINISH:SPEC-100016 936-0322	1
10	738-0140	VIS A EP.:.435 x.178-5/16 x.56	FINISH:MTD SPEC-100015	1
11	738-04237A	AXE EPAULE	FINISH:MTD SPEC-100016	1
12	738-04425	AXE EPAULE	FINISH:MTD SPEC-100016	1
13	746-05436	CABLE D EMBRAYAGE	VERKAPSELT	1
14	756-04310	POULIE MOTEUR	GETRIEBE:FINISH:SPEC-100015	1

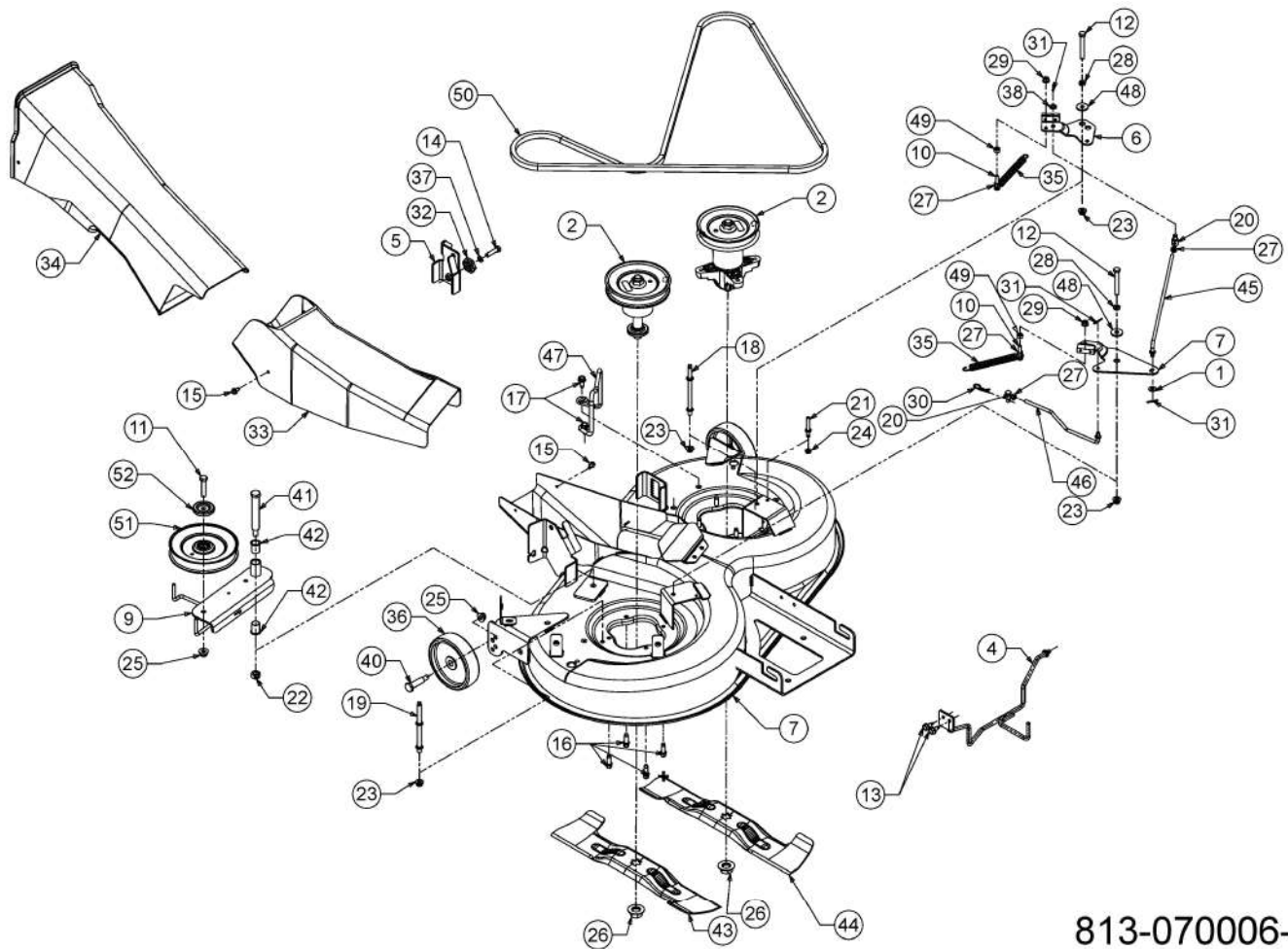

813-070006-38

# Plateau de coupe 92cm

Fig.	No. Pièces	Désignation	Numero de la norme	Nbr.
1	1751	RONDELLTE	1751	1
2	918-0324D	PALIER DE LAME CPL.D :	RIEMENSCHLEIBE 5.75 DIA	1
3	618-0409C	PALIER DE LAME COMPLET		1
4	647-04144A-Z	GUIDE COURROIE	FINISH:SPEC-101616 IN HU	1
5	683-04396637	SUPPORT	SCHWARZ	1
6	983-04409	FREIN DE LAME	LT5: NIETTEIL	1
7	983-04417	FREIN DE LAME	LT5: NIETTEIL	1
8	683-04418E-S			1
9	683-04420637	SUPPORT POULIE TENDEUR	SCHWARZ LACKIERT	1
10	710-0106	VIS HEX. 1/4-20:1.25:GR5:SPEC	FINISH:MTD SPEC-100015	2
11	710-0347	VIS HEX. 3/8-16:1.75:GR5:STD	FINISH:MTD SPEC-100015	1
12	710-0378	VIS HEX.:5/16-18:2.50:GR5:STD	FINISH:MTD SPEC-100015	2
13	710-04484	VIS HEX. TT:5/16-18:.750:HXIND	FINISH:MTD SPEC-100016 TYPE 1	2
14	710-0528	VIS HEX. 5/16-18:1.25:GR5:STD	FINISH:SPEC-100015 910-0528	1
15	710-0599	VIS A SIX PANS CREUX	FINISH:MTD SPEC-101617	2
16	710-06322	VIS	FINISH:SPEC-100016 TYPE 1	8
17	710-1260A	VIS TT:5/16-18:.750	FINISH:SPEC-100016 TYPE 1	2
18	711-05319	GUIDE COURROIE	SCHWEISSTEIL:FINISH:PHOS & OIL	1
19	711-05320	GUIDE COURROIE	SCHWEISSTEIL:FINISH:PHOS & OIL	1
20	711-0736	AXE	FINISH:MTD SPEC-100015	2
21	711-0993	GUIDE COURROIE	FINISH:701-01006 911-0993	1
22	712-0290	ECROU 7/16-14	FINISH:MTD SPEC-100015	1
23	712-04063	ECROU HEX. AVEC FLANC	FINISH:MTD SPEC-100015	4
24	712-04064	ECROU HEXAGONAL	FINISH:SPEC-100015 912-04064	1
25	712-04065	ECROU HEXAGONAL	FINISH:SPEC-100015 912-04065	3
26	712-05134	ECROU	FINISH:MTD SPEC-100015+WAX	2
27	712-3006	ECROU HEXAGONAL	FINISH:SPEC-100015	4
28	712-3007	ECROU HEX. 5/16-18 GR5	FINISH:MTD SPEC-100015	2
29	712-3027	ECROU HEXAGONAL 1/4-20:GRF	FINISH:MTD SPEC-100015	2
30	714-0145	GOUPILLE	FINISH:SPEC-701-01006	1
31	714-0507	GOUPILLE FENDUE 3/32 X .750	FINISH:MTD SPEC-100015	3
32	717-04074	PIGNON HAUTEUR PLATEAU	PHOS & SPEC-100015 917-04074	1
33	731-06251	CANAL D'EJECTION INFERIEUR	FINISH:SCHWARZ	1
34	731-06252	CANAL D'EJECTION SUPERIEUR	FINISH:SCHWARZ	1
35	732-0604A	RESSORT	FINISH:PHOS AND OIL	2
36	734-06265	ROULETTE DE PLATEAU	FINISH:KUNSTSTOFF SCHWARZ	2
37	736-0119	RONDELLE	FINISH:MTD SPEC-100016	1
38	736-0264	RONDELLE: .330 x.630 x.0635	FINISH:SPEC-100015 936-0264	1
40	738-0373	VIS A EPAULE .496x1.525:3/8-16	FINISH:MTD SPEC-100015	2
41	738-0476	VIS A EPAULE .625x3.50:7/16-14	FINISH:SPEC-100015	1
42	741-0591	BAGUE	FINISH:NATUR 941-0591	2
43	742-04020A	LAME í DROITE 18.40 LG	STAR BAG:W-RMEBEHANDELT	1
44	742-04021A	LAME í GAUCHE 18.40 LG	STAR BAG:W-RMEBEHANDELT	1
45	747-04781A	TIGE DE FREIN	MTD SPEC-101616 (YELLOW ZINC)	1
46	747-04782B	TIGE DE FREIN	FINISH:SPEC-100015	1
47	747-04840A	GUIDE COURROIE	FINISH:747-04840A-Z	1
48	748-0234	RONDELLE EPAULEE	FINISH:ROSTPREVENTION	2
49	750-05381	ENTRETOISE	FINISH:IN ÍL SAE 30 GEDIPPT	2
50	754-04175	COURROIE DE COUPE 92 CM	FINISH:	1
51	756-04050	POULIE DE COURR. TR. É 6.0"DIA	KUGELGELAGERT:SCHWARZ LACKIERT	1
52	783-08389	PROTECTION DE POULIE	FINISH:PLAIN	1

# Relevage plateau de coupe

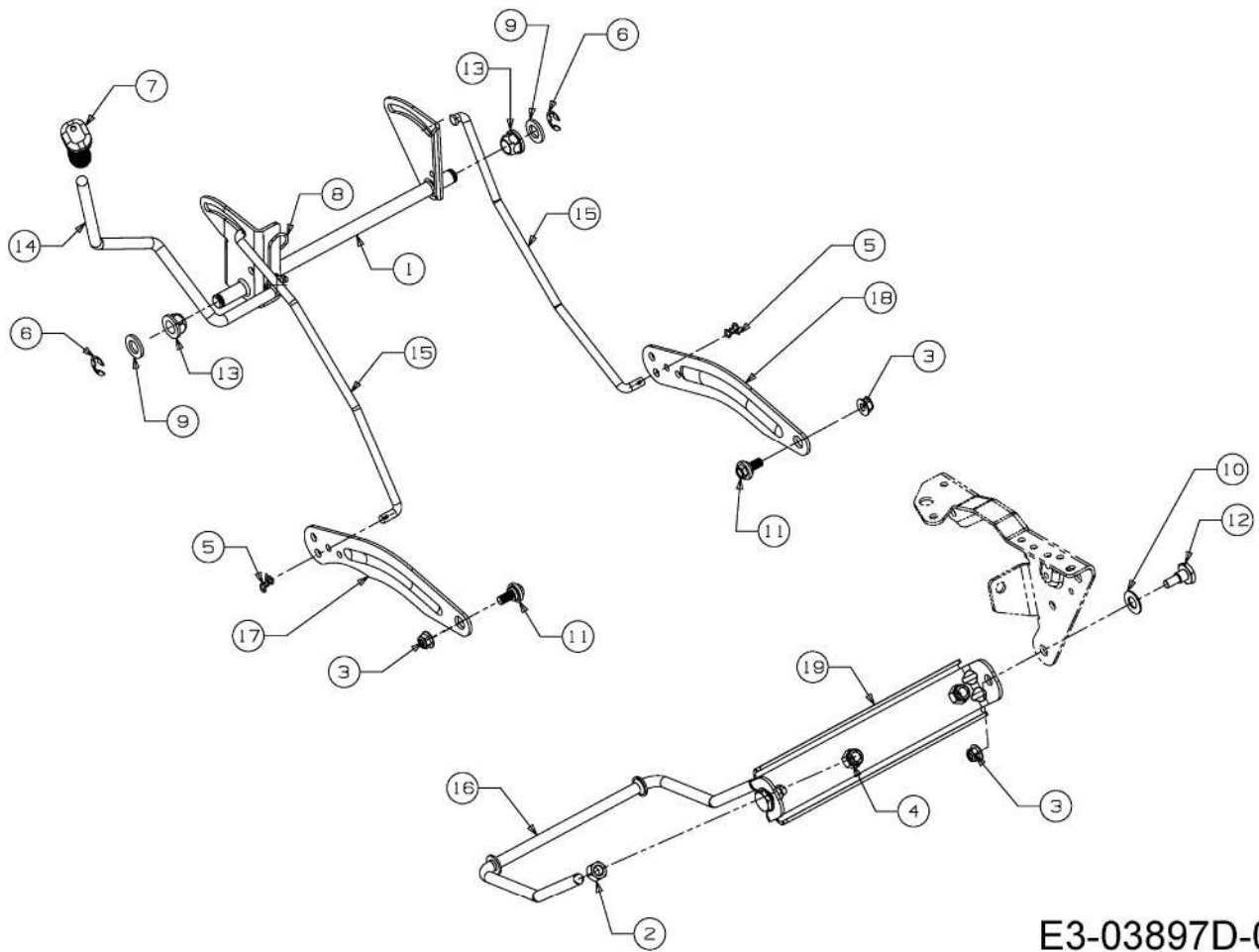

E3-03897D-01

# Relevage plateau de coupe

Fig.	No. Pièces	Désignation	Numero de la norme	Nbr.
1	683-04466637	AXE DE RELEVAGE	SCHWEISSTEIL:FINISH LACKIERT	1
2	712-0206	ECROU HEX. 1/2-13:GR.5	FINISH:MTD SPEC-100015	2
3	712-04065	ECROU HEXAGONAL	FINISH:SPEC-100015 912-04065	4
4	712-3083	ECROU HEX. 1/2-13:GRB:NYLON	FINISH:MTD SPEC-100015	2
5	714-04040	GOUPILLE	FINISH:ASTM F1941 FE/ZN 3AN	2
6	716-0106A	CIRCLIPS	FINISH:PHOSPHATIERT	2
7	720-0311	POIGNÉE LEVIER COUPE : 1/2	FARBE:SCHWARZ VINYL	1
8	732-04225	RESSORT	FINISH:MTD STD 701-01006	1
9	736-0366	RONDELLE 5/8 ID X 1.0 OD	FINISH:MTD SPEC-100015	2
10	736-0414	RONDELLE T_FLON	FINISH:WEISS: 936-0414	2
11	738-04130A	VIS EPAULEE	FINISH:SPEC-100016 TYPE 1	2
12	738-0507B	VIS	FINISH:MTD SPEC-701-01006	2
13	741-0225	BAGUE HEXAGONALE TEFLON 6 PANS	FINISH:KUNSTSTOFF SCHWARZ	2
14	747-04282	LEVIER DE RELEVAGE :LT-5	FINISH:SPEC-100015	1
15	747-04842	TRINGLE DE RELEVAGE	A/C/E/N-Deck:747-04842-Z	2
16	747-1324	TRINGLE	FINISH:SPEC-100015	1
17	783-04494C-S	LEVIER DE RELEVAGE DROITE	SCHWARZ	1
18	783-04711C-S	BRAS DE RELEVAGE GAUCHE	SCHWARZ	1
19	783-0720C637	SUPPORT DE RELEVAGE	SCHWARZ	1

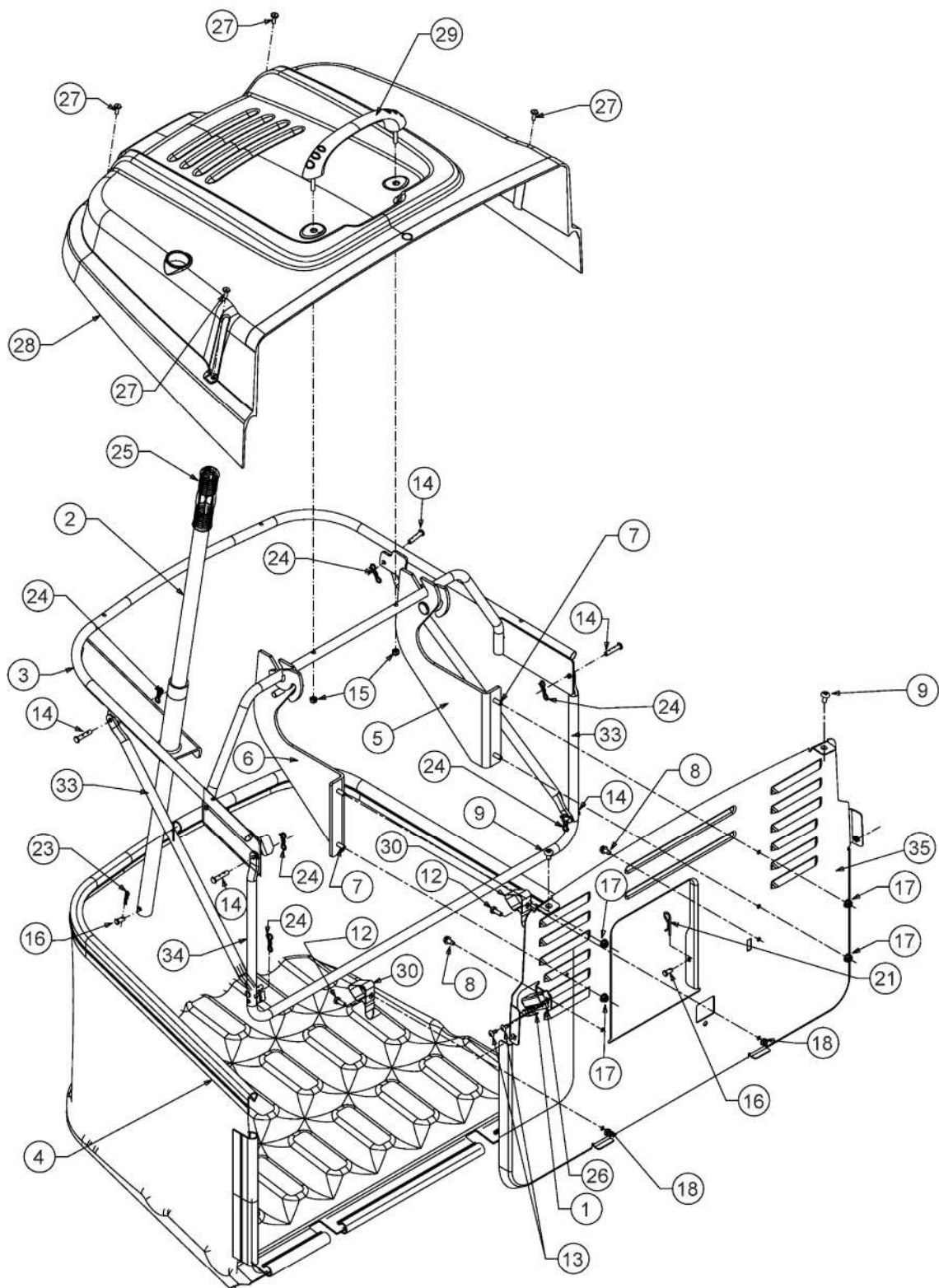

813-070004-18

# Dispositif de rÚception de l'herbe

Fig.	No. PiPces	DÚsignation	Numero de la norme	Nbr.
1	17962	PLAQUE DE SUPP. P. COMMUTATEUR	FINISH:WIE GESTANZT	1
2	649-04052637	BRAS DE RELEVAGE BAC	SCHWARZ LACKIERT	1
3	649-04076B-S	ARMATURE DE BAC	SCHWEISSTEIL:FINISH LACKIERT	1
4	664-04085A	TOILE BAC 200 L	LT-5:FINISH SCHWARZ	1
5	683-04421637	SUPPORT DE BAC GAUCHE	SCHWARZ	1
6	683-04422637	SUPPORT DE BAC DROITE	SCHWARZ	1
7	710-04666	VIS HEXAGONALE	FINISH:MTD SPEC-100015	4
8	710-0599	VIS A SIX PANS CREUX	FINISH:MTD SPEC-101617	2
9	710-1017	VIS	FINISH:MTD SPEC-100016	2
12	710-0751	VIS HEX.: 1/4-20:620:GR5:STD	FINISH:SPEC-100015	2
13	710-1760	VIS	PHOS & OIL (öhnlich 710-0779A)	2
14	711-04138	GOUJON í_PINGLER .25DIAX1.25L	FINISH:MTD SPEC-100015	6
15	712-0691	ECROU HEXAGONAL	MTD SPEC-100015 24.1426.14	2
16	711-0701	GOUJON	FINISH:MTD SPEC-100015	3
17	712-04064	ECROU HEXAGONAL	FINISH:SPEC-100015 912-04064	4
18	712-0324	ECROU HEX.:1/4-20:GR8:NYLON	FINISH:701-01000	2
21	714-0145	GOUPILLE	FINISH:SPEC-701-01006	2
23	714-04033	GOUPILLE FENDUE .072 x.92 LG	FINISH: MTD SPEC-100016	1
24	714-04040	GOUPILLE	FINISH:ASTM F1941 FE/ZN 3AN	6
25	720-0204	POIGNEE:1.0 ID x 4.7 LG	FINISH:SCHWARZ	1
26	725-04039	SECURITE	FINISH:GRAY/BLACK 925-04039	1
27	728-04044	RIVET	W_RTH #093614816	4
28	731-06106	COUVERCLE DE BAC	FINISH:KUNSTSTOFF SCHWARZ	1
29	731-06163	POIGNEE	FINISH:SCHWARZ	1
30	732-0838A	RESSORT CLIPS DE BAC	VERSCHLUSS:FINISH SPEC-100015	2
33	749-04108637	BARRE LAT BAC 250 LITRE	500 MR SCHWARZ LACKIERT	2
34	749-04418637	ARMATURE DE BAC	SCHWARZ	1
35	783-05731637	PLAQUE ARRIERE	SCHWARZ LACKIERT	1



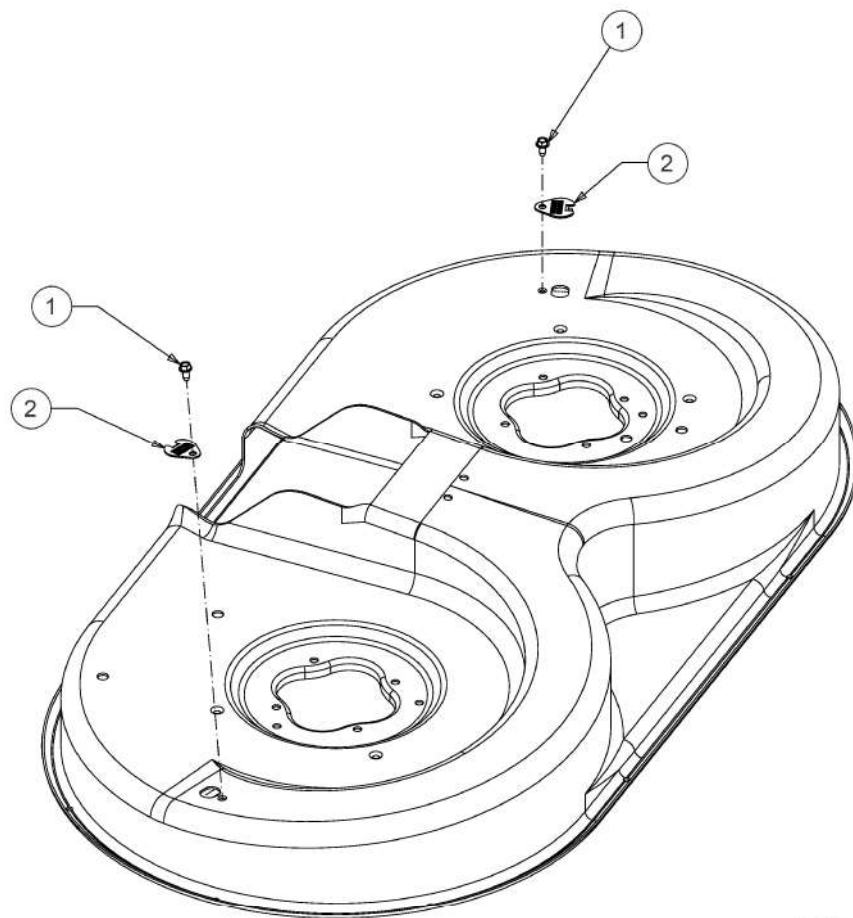

E3-11406A-01

## TuyPre nettoyage

Fig.	No. Pièces	Désignation	Numero de la norme	Nbr.
1	710-0599	VIS A SIX PANS CREUX	FINISH:MTD SPEC-101617	2
2	783-06464	BOUCHON	FINISH:MTD SPEC-100015	2

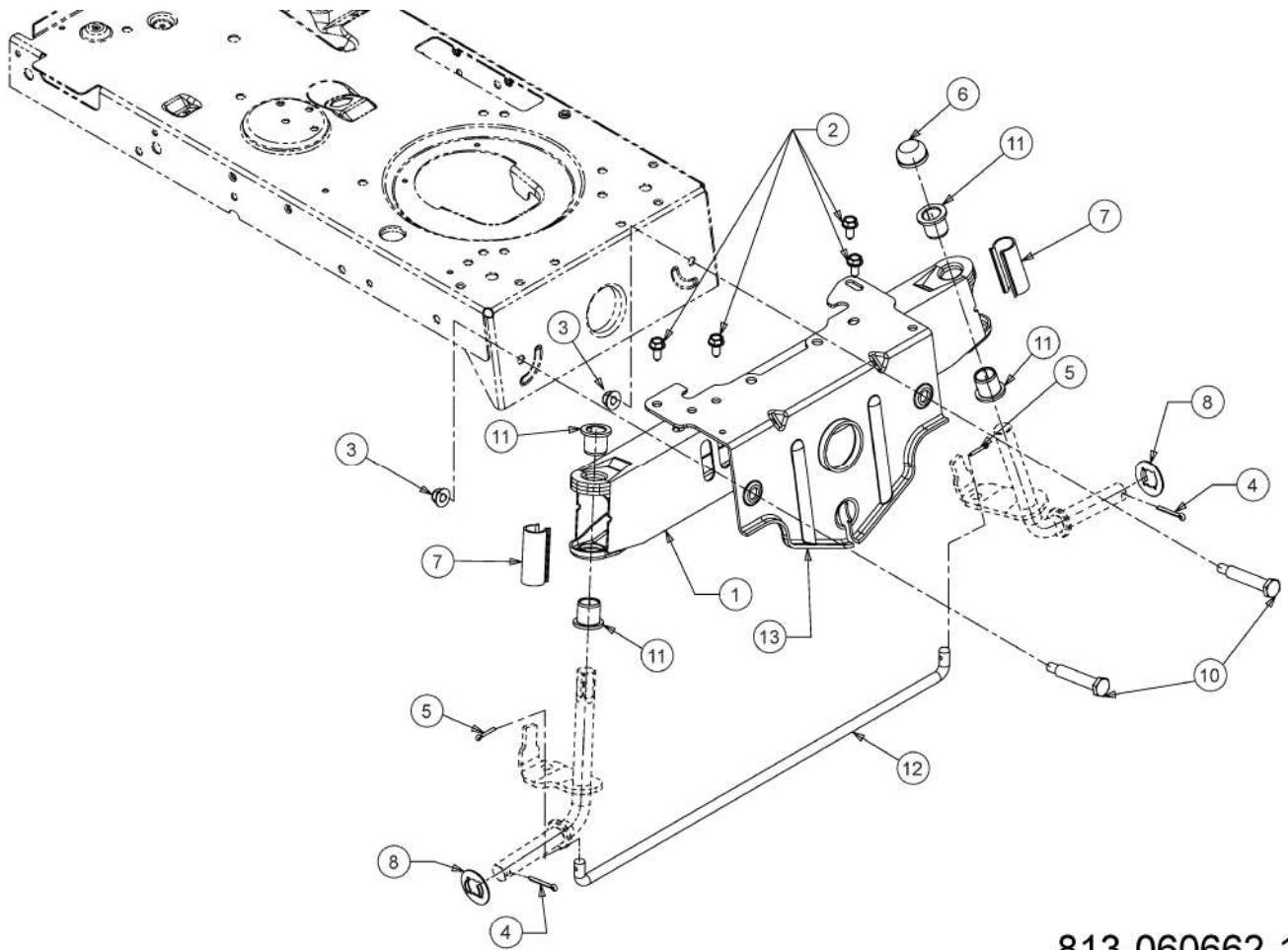

813-060662-11

## Axe avant

Fig.	No. Pièces	Désignation	Numero de la norme	Nbr.
1	683-0128B637	ESSIEU AVANT	SCHWARZ GEPULVERT	1
2	710-04484	VIS HEX. TT:5/16-18:.750:HXIND	FINISH:MTD SPEC-100016 TYPE 1	4
3	712-04065	ECROU HEXAGONAL	FINISH:SPEC-100015 912-04065	2
4	714-0162	GOUPILLE FENDUE 5/32:1.25	FINISH:MTD SPEC-100015	2
5	714-0474	GOUPILLE	FINISH:MTD SPEC-100015	2
6	726-0341	CAPUCHON CLIPS	FINISH:SCHWARZ	1
7	731-04057A	PALIER DE GRAISSAGE	LT5:MATERIAL PP SCHWARZ	2
8	736-04228B	RONDELLE	SPECIAL:FINISH SPEC-701-100015	2
10	738-04128	VIS A EPAULE .500x2.38:3/8-16	FINISH:MTD SPEC-100015	2
11	741-0660A	BAGUE ESSIEU DE ROUE	FINISH:KUNSTSTOFF SCHWARZ	4
12	747-04299A	TRINGLE DE DIRECTION	FINISH:SPEC-100015 or E-Coat	1
13	783-05326D-S	SUPPORT AVANT	783-05326D-S	1

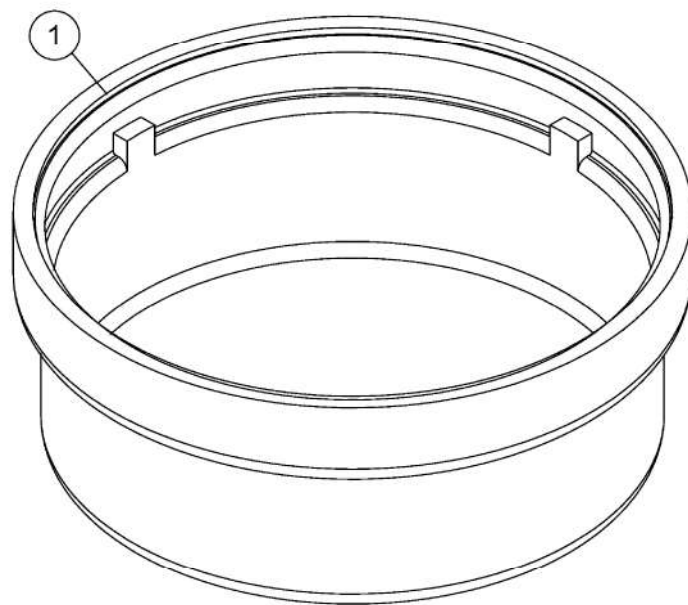

813-062012-00

# Enjoliveur

Fig.	No. Pièces	Désignation	Numero de la norme	Nbr.
1	731-0484A	ENJOLIVEUR DEVANT	KUNSTSTOFF SCHWARZ 931-0484A	2

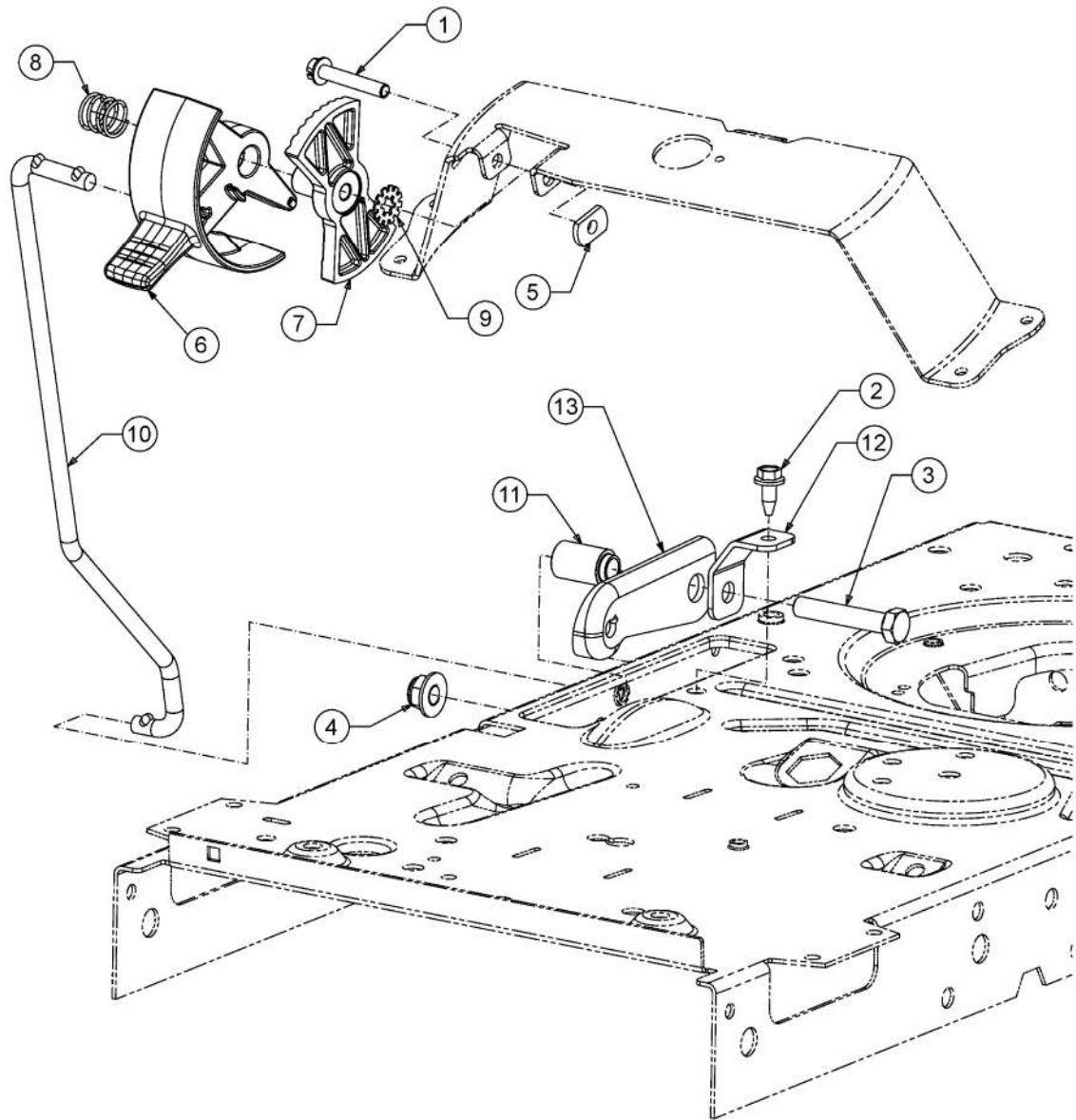

813-061032-10

# Frein d'arrût

Fig.	No. Pièces	Désignation	Numero de la norme	Nbr.
1	710-04860C		710-04860C	1
2	710-1652	VIS HEX. TT:1/4-20:.625:HXINDW	FINISH:MTD-SPEC-100016 TYPE 1	1
3	710-3184A	VIS	710-3184A	1
4	712-04065	ECROU HEXAGONAL	FINISH:SPEC-100015 912-04065	1
5	712-0414	ECROU 1/4-20	FINISH:PLAIN	1
6	731-07885B	POIGNEE DE VITESSE	FINISH:KUNSTSTOFF GELB	1
7	731-07895A	INDICATION DE VITESSE	FINISH:PLAIN (SCHWARZ)	1
8	732-04877	RESSORT	FINISH:MTD SPEC-100015	1
9	736-3006	RONDELLE 1/4 X -75	FINISH:SPEC-100016	1
10	747-05398	TRINGLE DE VITESSE	FINISH:SPEC-100015	1
11	750-04465C	ENTRETOISE	FINISH:GEILT	1
12	783-06823	SUPPORT	KONTROLLHEBEL:VERZ.SIEHE ZG.	1
13	783-06991	SUPPORT	SD-TR./HYDRO:783-06991-Z	1



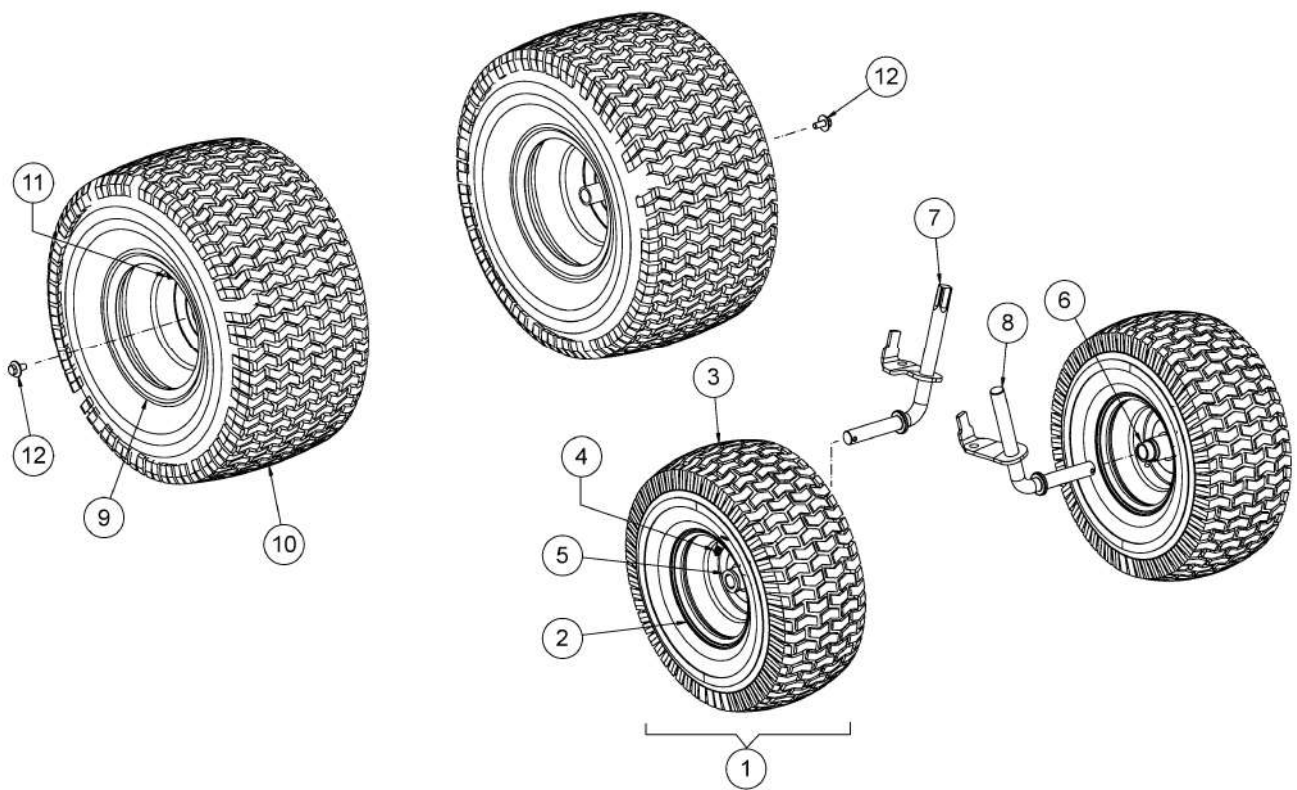

813-500112-04OG

## Roues, fusées d'essieu

Fig.	No. Pièces	Désignation	Numero de la norme	Nbr.
1	634-04406-G	ROUE COMPLETE 15X6.0X6 GRISE	FELGE:OYSTER GRAY 788-0662	2
2	634-04405662	JANTE AVANT GRISE	FINISH:OYSTER GRAY 788-0662	2
3	734-1731	PNEU 15X600X6 DICO MULTI-TRAC	SQ SHOULDER:TURF SAVER	2
4	734-0255	VALVE:PNEU	TR 412-P / 32.6mm / 934-0255	2
5	741-0990B	BAGUE DE ROUE AVEC GRAISSEUR	m.SCHMIERNIPPEL:FINISH SCHWARZ	2
6	741-0516B	BAGUE DE ROUE .760x1.00x1.20	FINISH:SCHWARZ	2
7	638-04013637	FUSEE DROITE	SCHWEISSTEIL:LACKIERT	1
8	638-04014A-S	FUSEE GAUCHE	SCHWARZ	1
9	634-04369-G	634-04369-WY	FINISH:OYSTER GRAY GEPULVERT	2
10	734-1729	PNEU 18 X 9,50 - 8	CHARLISLE	2
11	734-0255	VALVE:PNEU	TR 412-P / 32.6mm / 934-0255	2
12	710-05339A	VIS	FINISH:MTD STD SPEC-101617	2

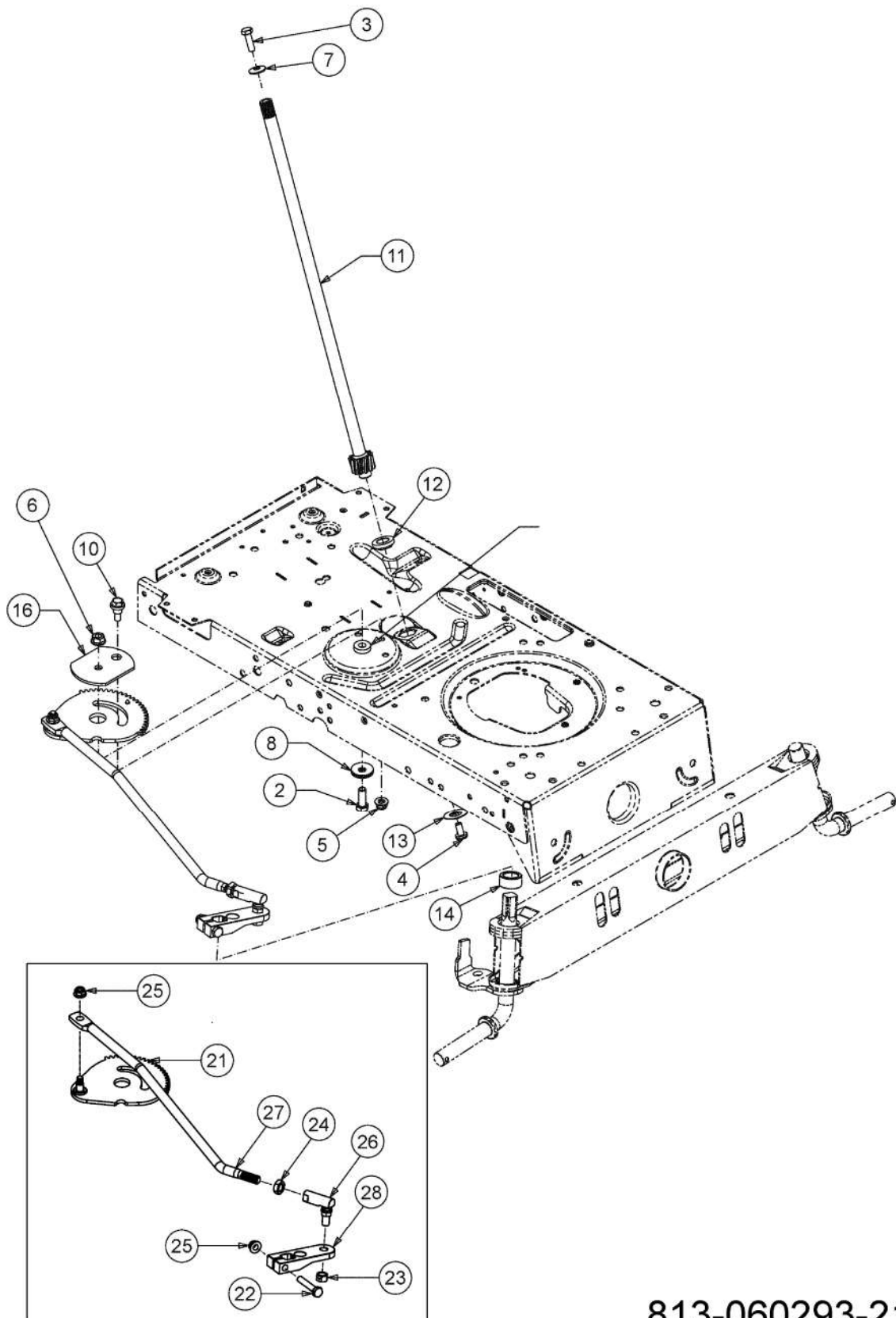

813-060293-21

## Système direction

Fig.	No. Pièces	Désignation	Numero de la norme	Nbr.
2	710-0514	VIS HEX.:3/8-16:1.00:GR5:STD	FINISH:MTD SPEC-100015	1
3	710-0643	VIS HEX.: 5/16-18:1.00:GR5	FINISH:MTD SPEC-100015	1
4	710-1309	VIS	FINISH:MTD SPEC-100015	1
5	712-04063	ECROU HEX. AVEC FLANC	FINISH:MTD SPEC-100015	1
6	712-0431	ECROU STOP 3/8-16:GRF	FINISH:MTD SPEC-100015	1
7	736-0242	RONDELLE CONIQUE.340X.872X.060	FINISH:MTD SPEC-100016	1
8	736-0331	RONDELLE CONIQUE	FINISH:MTD SPEC-100016	1
10	738-04141	AXE	FINISH:SPEC-100015	1
11	738-07154		738-07154	1
12	741-04124	PALIER DE BRIDE	FINISH:PLAIN	1
13	748-0389	BAGUE	FINISH:GEÍLT	1
14	748-04068	DOUILLE .71IDX.125 ODX.56 LG	FINISH:SPEC-100015	1
15	750-06192A	ENTRETOISE	FINISH:DAMPFBEBANDEL	1
16	783-08577A	PLAQUE DE SEGMENT	FINISH:PHOS&OIL or SPEC-100015	1
21	617-04094	SEGMENT DE DIRECTION	SCHWEISSTEIL:PHOS & OIL	1
22	710-3180	VIS HEX. 5/16-18:1.75:GR5:STD	FINISH:SPEC-100015	1
23	712-0214	ECROU	FINISH:SPEC-100015	1
24	712-0240	ECROU HEX.: 7/16-20:GR2	FINISH:MTD SPEC-100015	1
25	712-04063	ECROU HEX. AVEC FLANC	FINISH:MTD SPEC-100015	2
26	723-0448A	ROTULE DE DIRECTION 7/16-20	FINISH:MTD SPEC-100015	1
27	747-05385A	TRINGLE DE DIRECTION	FINISH:MTD SPEC 701-01007	1
28	748-04278-Z	BIELETTE DE DIRECTION	FINISH:MTD-SPEC-100015	1
28	748-04278ZW	BIELETTE DE DIRRECTION	FINISH:BLAU CHROMATIEREN	1

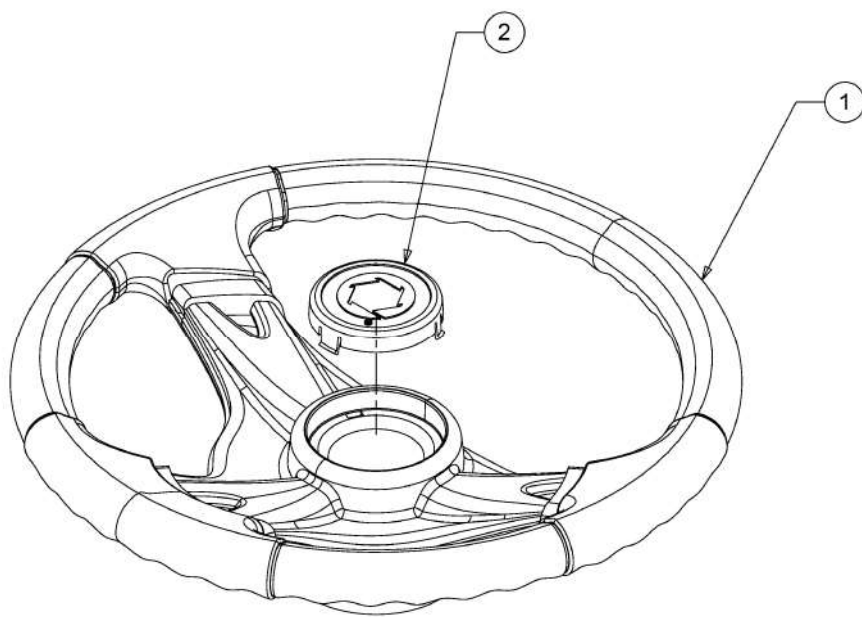

813-010305-00

# Volant

Fig.	No. Pièces	Désignation	Numero de la norme	Nbr.
1	631-04028	VOLANT	FINISH SCHWARZ	1
2	731-04681		FINISH: SCHWARZ NON CE	1

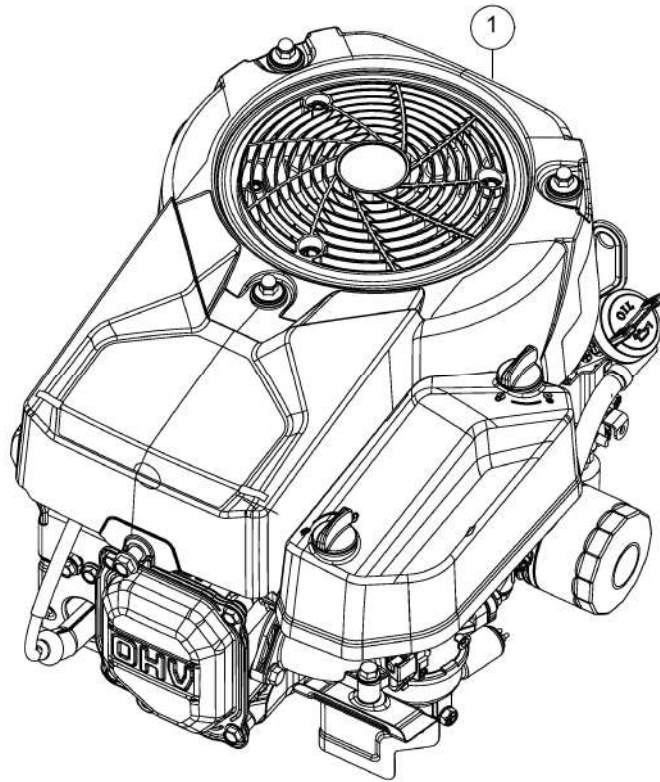

E3-11416A-01

# Moteur

Fig.	No. Pièces	Désignation	Numero de la norme		Nbr.
1	752Z7T90HW		MODELL#:7T90HW	STAGE V	1



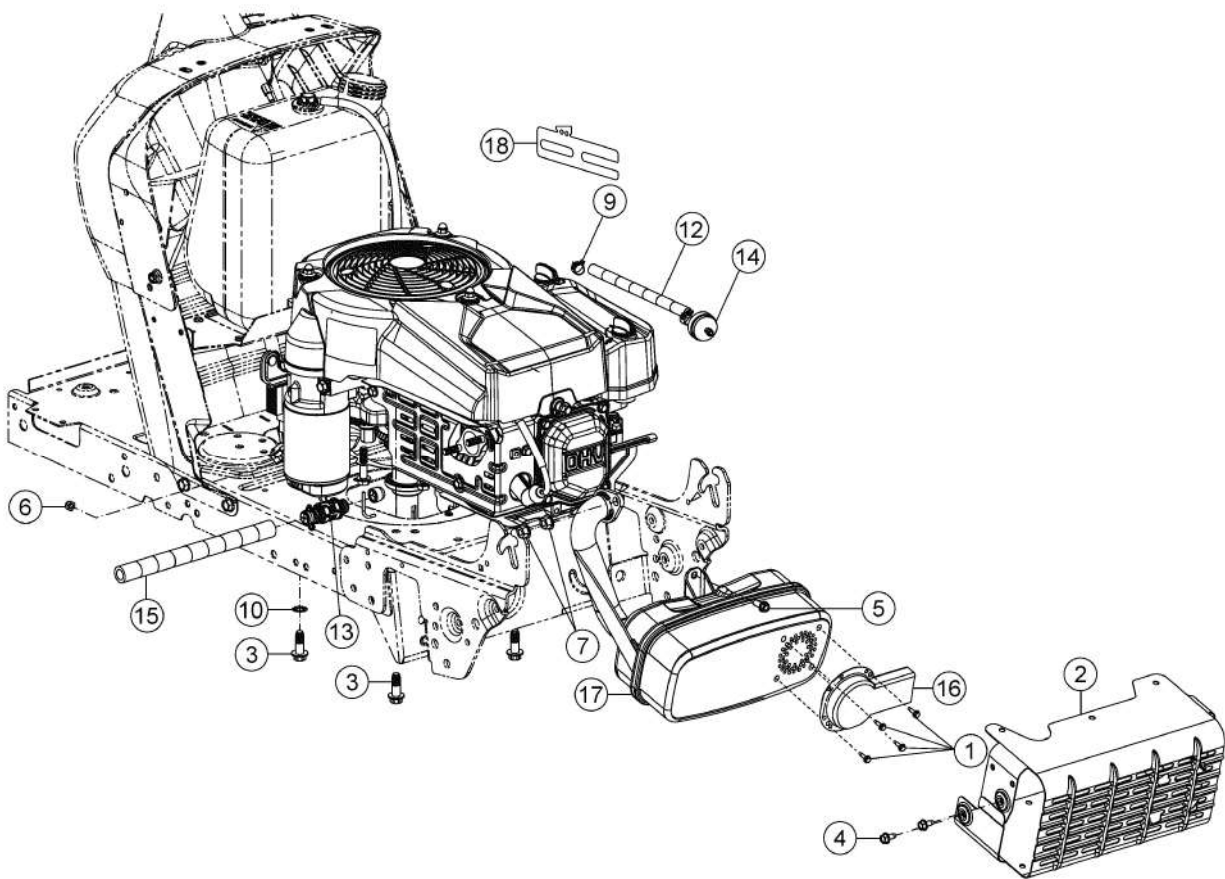

813-070789-00

## Accessoires moteur

Fig.	No. Pièces	Désignation	Numero de la norme	Nbr.
1	710-06625	VIS 8-32X0.47:HXWSH	FINISH:ASTM F1137 GRADE D	4
2	683-05460A-S	PROTECTION D ECHAPPEMENT NOIR	SCHWARZ	1
3	710-04683C	VIS	FINISH:SIEHE ZG.	4
4	710-0599	VIS A SIX PANS CREUX	FINISH:MTD SPEC-101617	4
5	710-0642	VIS1/4-20:0.750	SPEC-100016 TYPE 1 910-0642	1
6	712-0691	ECROU HEXAGONAL	MTD SPEC-100015 24.1426.14	1
7	712-3086	ECROU/FLANC: M8-1.25	FINISH:MTD SPEC-100015	2
9	726-0205	COLLIER DE SERRAGE DE BOYAU	FINISH:PHOS UND GELB LACKIERT	2
10	736-0148	RONDELLE	FINISH:MTD SPEC-100016	1
12	751-10349-54	TUYAU ESSENCE 54"	751-10349-54	7
13	751-10517A	DRAINAGE D <sub>2</sub> HUILE	FINISH:SIEHE ZG.	1
14	751-3013	FILTRE ESSENCE	COLOR:RED 951-3013	1
15	751-3141	TUYAU VIDANGE	13 X 3:FINISH KLAR METERWARE	9
16	751-11053B		LANGER ABGASKANAL:ALUMINIZED	1
17	751-15799A	POT D ECHAPPEMENT	751-15799A	1
18	783-06232-Z	SUPPORT	FINISH:VERZINKT	1

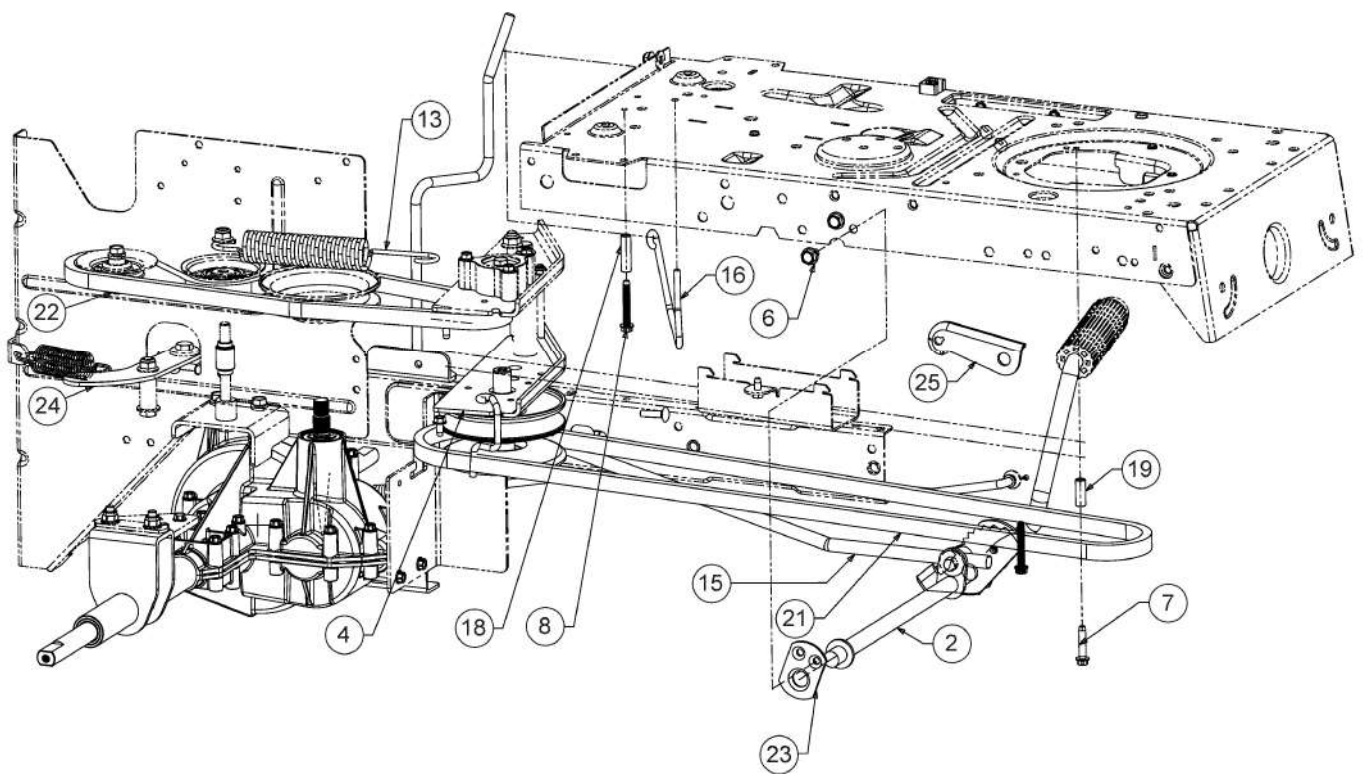

813-070005-28A

## Entraînement de roulement, Pedale

Fig.	No. Pièces	Désignation	Numero de la norme	Nbr.
2	647-04132A		SCHWEISSTEIL:LACKIERT	1
4	683-04429A-S	SUPPORT VARIATEUR	HECKAUSWURF: SCHWARZ LACKIERT	1
6	710-0604A	VIS 5/16-18:0.625	FINISH:MTD SPEC-100016 TYPE 1	2
7	710-0809	VIS HEX. TT:1/4-20:1.250:HXIND	FINISH:MTD SPEC-100016 TYPE 1	1
8	710-1026	VIS HEX:TT:1/4-20:1.750	FINISH:MTD-SPEC-100016	1
15	747-04780	TRINGLE	LT-5 FINISH:MTD STD 100015	1
16	747-04803	TIGE	FINISH:LACKIERT	1
18	750-04456	ENTRETOISE	FINISH:MTD SPEC-100015	1
19	750-0566A	ENTRETOISE	FINISH:MTD SPEC-100015	1
21	754-04211	COURROIE MOTEUR VARIATEUR	POLY	1
22	754-04268	COURROIE VARIATEUR PONT LT5	POLY	1
23	783-04536B		FINISH:LACKIERT MTD QUALIT-T	1
24	783-06623	SUPPORT	FINISH:MTD SPEC-100015	1
25	783-06991	SUPPORT	SD-TR./HYDRO:783-06991-Z	1

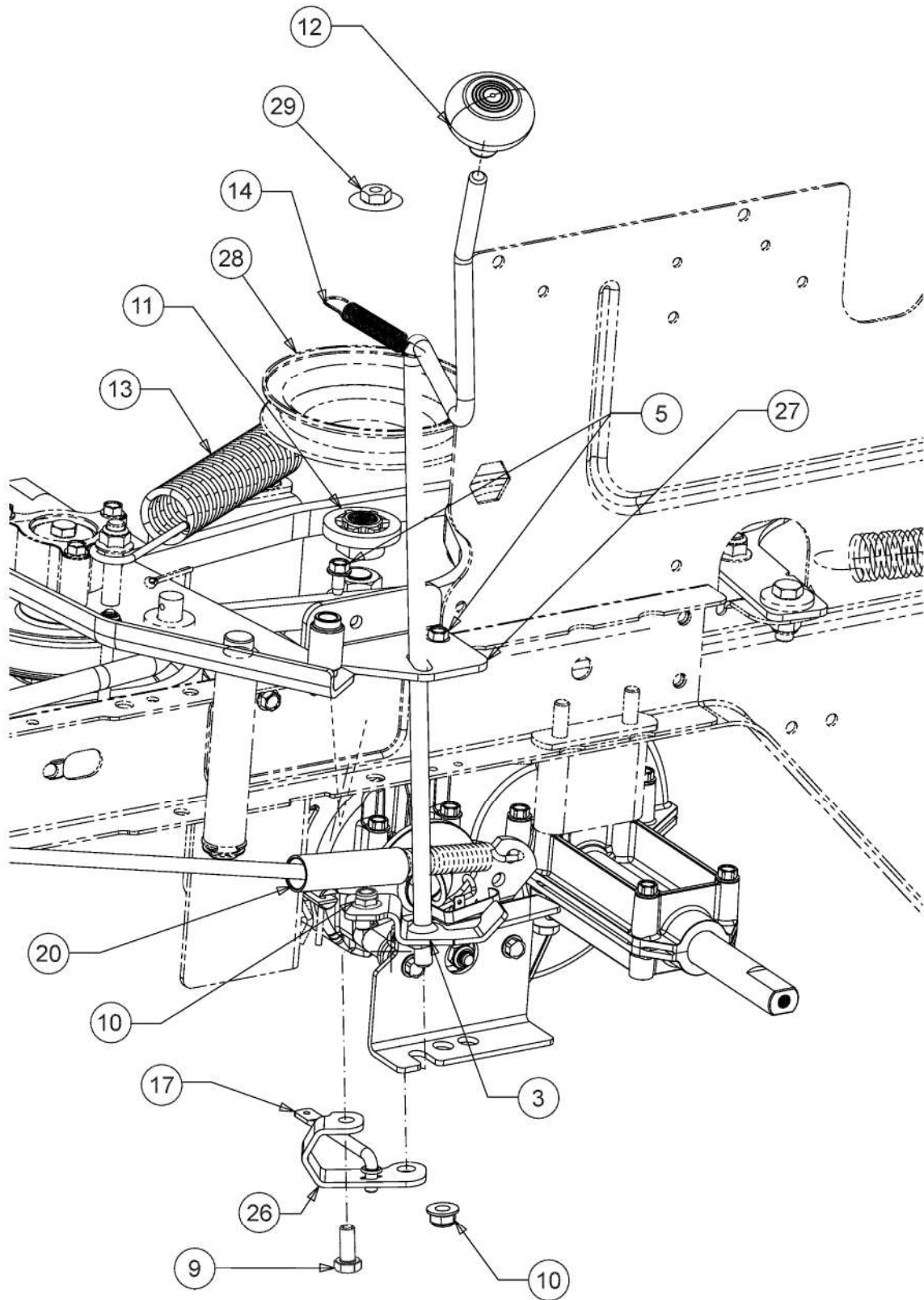

813-070005-28B

## Levier de commande

Fig.	No. Pièces	Désignation	Numero de la norme	Nbr.
3	647-05112A	LEVIER INVERSEUR	SCHWEISSTEIL:BLAU CHROMATIERT*	1
5	710-0599	VIS A SIX PANS CREUX	FINISH:MTD SPEC-101617	2
9	710-3025	VIS	FINISH:MTD SPEC-100015	1
10	712-04063	ECROU HEX. AVEC FLANC	FINISH:MTD SPEC-100015	1
11	718-04407	MOYEU: POULIE:5/8 DENTELURE	VERZAHNUNG	1
12	720-04028	POIGNEE INVERSEUR	FINISH:SCHWARZ	1
13	732-04517	RESSORT	FINISH:PHOS AND OIL	1
14	732-05609		FINISH:MTD SPEC 701-01006	1
17	747-06967	TIGE	LT5-RD:FINISH:MTD SPEC-100015	1
20	750-0802	ENTRETOISE / .640IDX.760DX2.63	FINISH:KUNSTSTOFF SCHWARZ	1
26	783-09625	SUPPORT	FINISH:BLAU CHROMATIERT *	1
27	783-09677	SUPPORT	FINISH:BLAU CHROMATIERT *	1
28	756-04298	POULIE DE PONT	PINS:FINISH:SIEHE ZG.656-04044	1
29	712-0700	ECROU HEXAGONAL	SPEC-100015+WAX 912-0700	1

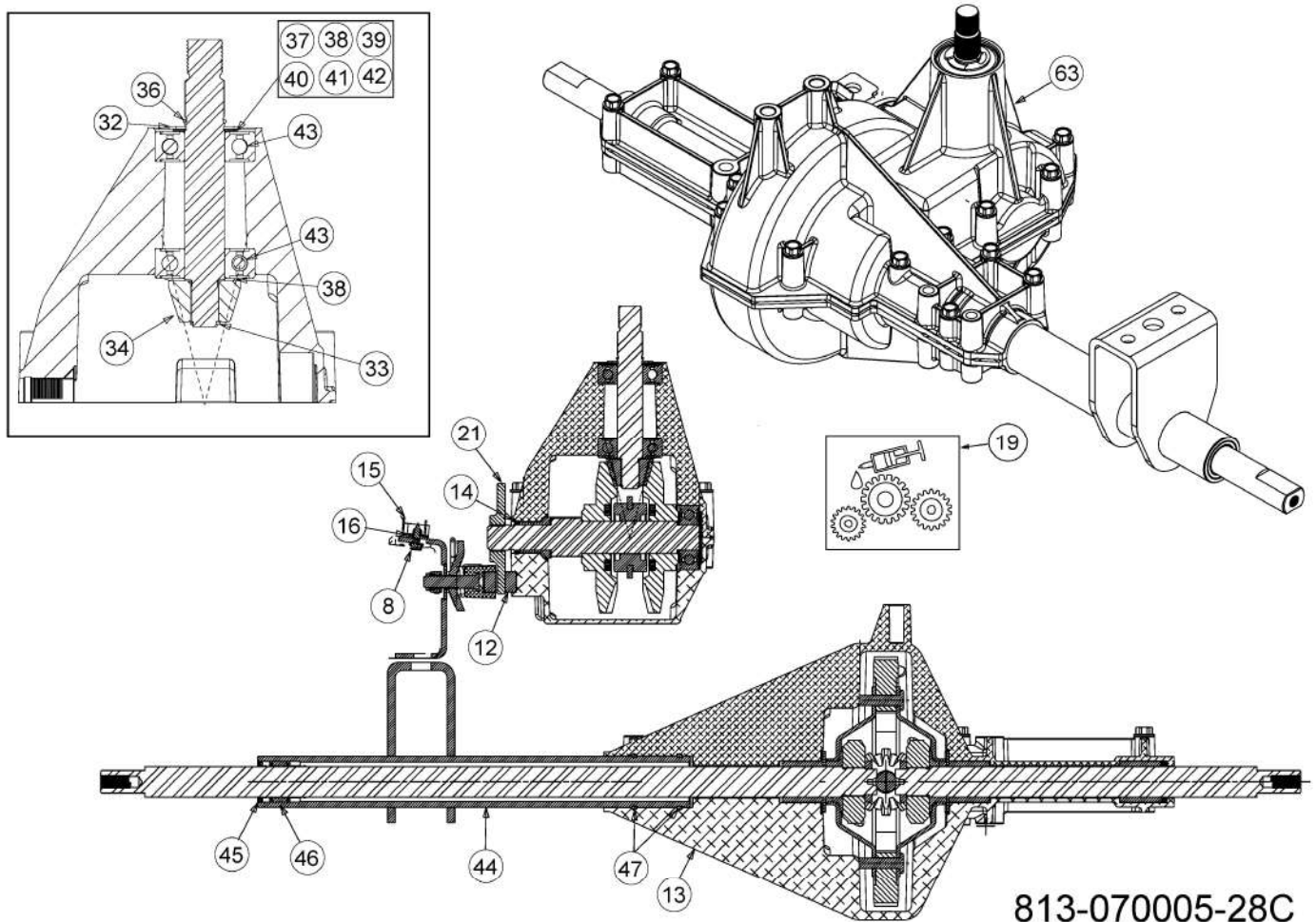

813-070005-28C

# Boîte de vitesse 1

Fig.	No. Pièces	Désignation	Numero de la norme	Nbr.
8	710-0227	VIS	FINISH:MTD SPEC-100016 TYPE 1	2
12	717-0678	PLAQUETTE DE FREIN	FINISH:	1
13	719-04358	CARTER INFERIEUR	FINISH:WIE GEGOSSEN	1
14	721-0213	JOINT SPI .625x.812x.094	FINISH:	1
15	725-1644	INTERRUPTEUR DE S_CURIT_	FINISH:MTD SPEC-100015	1
16	726-0320	PLAQUE D'ISOLATION	FINISH:NATUR ODER SCHWARZ	1
17	732-05586		FINISH:PHOS AND OIL	1
19	6021-U1-1073	GRAISSE (400G)	+Li12 HYDROXYSTEARAT	X
21	761-0202	DISQUE DE FREIN	FINISH:İL UND FETTFREI	1
32	716-0231	CIRCLIPS	FINISH:SPEC-100016	1
33	716-0385	CIRCLIPS	SHR-39:FINISH PHOS & OIL	1
34	717-1760	PIGNON CONIQUE 14 T	FINISH:SIEHE ZG.	1
36	732-0614	CIRCLIPS	FINISH:ZINC PHOSPHATE	1
37	736-0336	RONDELLE 5/8X1.00X.030	FINISH:MTD SPEC-100016	1
38	736-0337	RONDELLE 5/8 IDX1.0 ODX.040	MTD STD 701-01001 936-0337	2
39	736-0349	RONDELLE 5/8 IDX10 OD X .020	FINISH:SIEHE ZG.	1
40	736-04337	RONDELLE	FINISH:GEİLT	1
41	736-0494	RONDELLE	FINISH:MTD SPEC-100016	1
42	736-0495	RONDELLE	FINISH:SIEHE ZG. 936-0495	1
43	741-0524A	ROULEMENT	FINISH:SIEHE CHART *	2
44	618-04538		SCHWEISSTEIL:FINISH:PHOS & OIL	1
45	721-0338	JOINT	.75 x 1.00 x .125:FINISH STD	1
46	741-04288	CAGE AIGUILLE	741-04288	1
47	721-0521	JOINT 1.174 ID X 103 THK	FINISH:NONE	2
63	618-07408B	TRANSMISSION ENS.	618-07408B	1



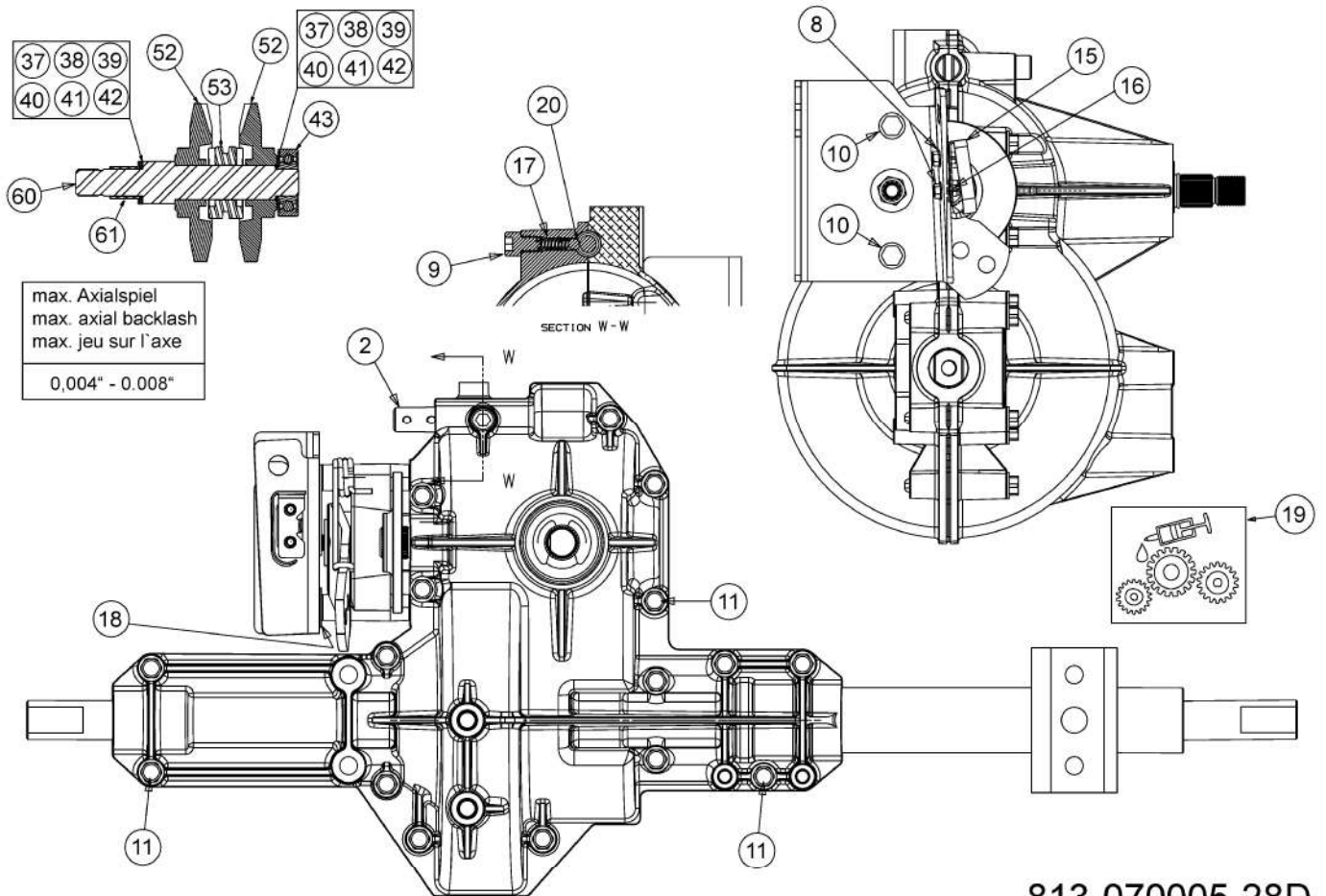

max. Axialspiel  
 max. axial backlash  
 max. jeu sur l'axe  
 0,004" - 0,008"

813-070005-28D

## Boîte de vitesse 2

Fig.	No. Pièces	Désignation	Numero de la norme	Nbr.
2	611-05186	FOURCHETTE	FINISH:	1
8	710-0227	VIS	FINISH:MTD SPEC-100016 TYPE 1	2
9	710-04731	VIS	FINISH:MTD SPEC-100016	1
10	710-1206	VIS HEX. TT:1/4-20:2.375	FINISH:MTD SPEC-100016 TYPE 1	2
11	710-1325	VIS HEXAGONALE	FINISH:SPEC-100016 TYPE 1	17
15	725-1644	INTERRUPTEUR DE S_CURIT_	FINISH:MTD SPEC-100015	1
16	726-0320	PLAQUE D'ISOLATION	FINISH:NATUR ODER SCHWARZ	1
17	732-05586		FINISH:PHOS AND OIL	1
18	736-0342	RONDELLE PLATE .283 x.75 x.030	FINISH:MTD STD 701-01000	1
19	6021-U1-1073	GRAISSE (400G)	+Li12 HYDROXYSTEARAT	X
20	741-1134	BILLE	FINISH:SIEHE ZG.	1
37	736-0336	RONDELLE 5/8X1.00X.030	FINISH:MTD SPEC-100016	1
38	736-0337	RONDELLE 5/8 IDX1.0 ODX.040	MTD STD 701-01001 936-0337	1
39	736-0349	RONDELLE 5/8 IDX10 OD X .020	FINISH:SIEHE ZG.	1
40	736-04337	RONDELLE	FINISH:GEILT	1
41	736-0494	RONDELLE	FINISH:MTD SPEC-100016	1
42	736-0495	RONDELLE	FINISH:SIEHE ZG. 936-0495	1
43	741-0524A	ROULEMENT	FINISH:SIEHE CHART *	1
52	717-05425	PIGNON 55 DENTS	FINISH:OIL DIPPED	2
53	718-04381	CRABOT	718-04381P	1
60	711-04823	ARBRE DE TRANSMISSION	711-04823	1
61	741-04458	BAGUE	FINISH:IL-IMPR-GNIERT	1

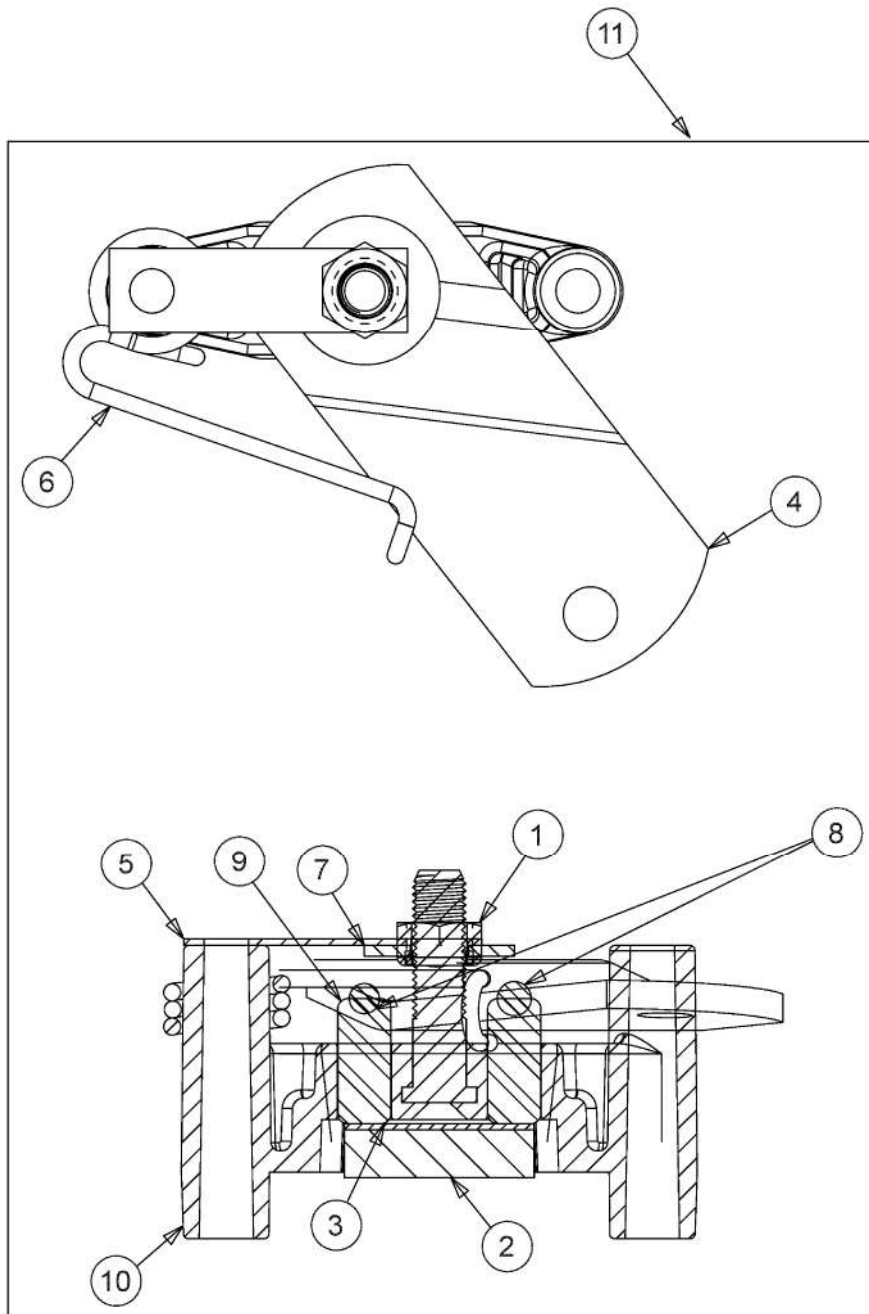

813-070005-28E

# Frein

Fig.	No. Pièces	Désignation	Numero de la norme	Nbr.
1	712-0273	ECROU HEXAGONAL 5/16-24"	FINISH:MTD SPEC-100015	1
2	717-0678	PLAQUETTE DE FREIN	FINISH:	1
3	717-0682	INSERT DE FREIN	FINISH:NONE 917-0682	1
4	717-0772B	LEVIER DE FREIN	FINISH:PHOSPHATE & OIL	1
5	718-0150	LANG. DE SUPP.: ANTI ROTATION	FINISH:SPEC-100015	1
6	732-0743	RESSORT	FINISH:ZINC PHOS&OIL 932-0743	1
7	736-0371	RONDELLE 1.344XA .875"	FINISH:MTD SPEC-100016	1
9	741-0343	GOUJON DE PRESSION 5/16"	FINISH:SIEHE ZG. 941-0343	2
10	761-0198B	APPUI DE FREIN	FINISH:NONE 961-0198B	1
11	661-0006	SUPPORT PLAQUETTE FREIN	FINISH:	1

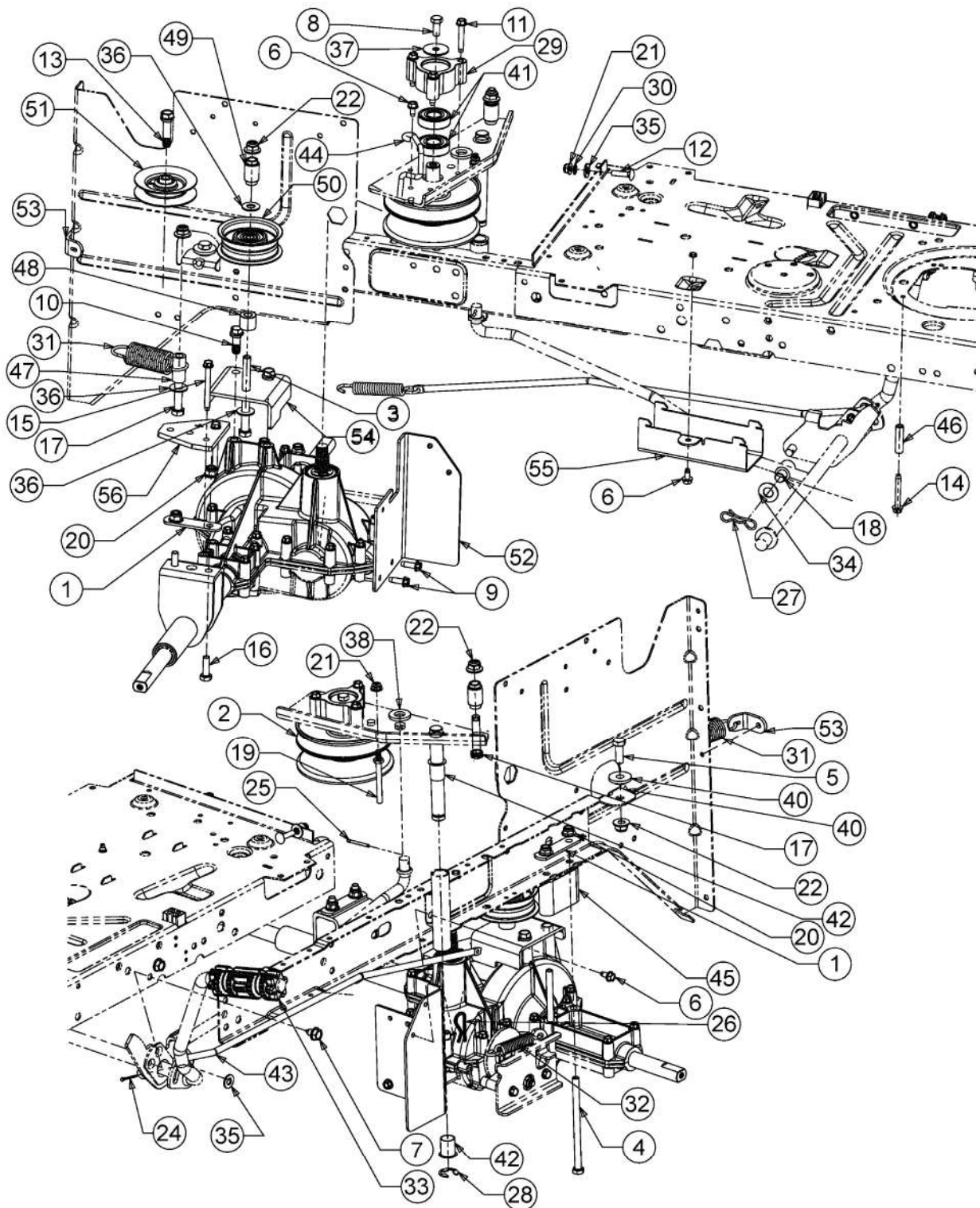

813-070030-23

# Entraineur de roulement, Variateur

Fig.	No. Pièces	Désignation	Numero de la norme	Nbr.
1	17840	SUPPORT	FINISH: 17840-Z	2
2	656-05011	POULIE VARIATEUR	FINISH:SEE DRW	1
3	710-0411	VIS HHCS:3/8-16:4.00:GR5:STD	FINISH:SPEC-100015	1
4	710-04469	VIS HEX. 5/16-18X5.00:GR5:STD	FINISH:MTD SPEC-100015	2
5	710-0514	VIS HEX.:3/8-16:1.00:GR5:STD	FINISH:MTD SPEC-100015	1
6	710-0599	VIS A SIX PANS CREUX	FINISH:MTD SPEC-101617	4
7	710-0604A	VIS 5/16-18:0.625	FINISH:MTD SPEC-100016 TYPE 1	2
8	710-0627	VIS HEX. 5/16-24:.750 GR5:LOCK	FINISH:MTD SPEC-100015	1
9	710-0642	VIS1/4-20:0.750	SPEC-100016 TYPE 1 910-0642	2
10	710-0654A	VIS A SIX PANS CREUX	FINISH:GEOMET XL	2
11	710-0778	VIS HEX. TT:1/4-20:1.500	FINISH:MTD SPEC-100016 TYPE 1	3
12	710-0932A	VIS	FINISH:MTD SPEC-100015	1
13	710-1007	VIS HEX.TTSEMS3/8-16:1,500	FINISH:STD SPEC-100016	1
14	710-1026	VIS HEX.TT:1/4-20:1.750	FINISH:MTD-SPEC-100016	1
15	710-1206	VIS HEX. TT:1/4-20:2.375	FINISH:MTD SPEC-100016 TYPE 1	2
16	710-0376	VIS HEX.:5/16-18:1.00:GR5:STD	FINISH:MTD SPEC 701-01006	2
17	710-3144	VIS HEX.: 3/8-16:2.00:GR5:STD	FINISH:SPEC-100015 910-3144	2
18	711-04036	AXE	FINISH:SPEC-100015 911-04036	1
19	711-04826	GUIDE COURROIE	BLACK OXIDE ODER PHOS & OIL	1
20	712-04063	ECROU HEX. AVEC FLANC	FINISH:MTD SPEC-100015	4
21	712-04064	ECROU HEXAGONAL	FINISH:SPEC-100015 912-04064	2
22	712-04065	ECROU HEXAGONAL	FINISH:SPEC-100015 912-04065	4
24	714-0111	GOUPILLE FENDUE 3/32:1.0"	FINISH:MTD SPEC-100015	1
25	714-0115	GOUPILLE FENDUE 1/8 x 1.0	FINISH:MTD SPEC-100015	1
26	714-0209	GOUPILLE FENDUE	FINISH:SPEC 701-01006 914-0209	1
27	714-05005	GOUPILLE	FINISH:ASTM F1941 FE/ZN 3AN	1
28	716-0106A	CIRCLIPS	FINISH:PHOSPHATIERT	1
29	718-04261	CAGE DE ROULEMENT	FINISH:ROSTSCHUTZ SIEHE ZG.	1
30	726-0233	RONDELLE	MECHANISCH KLAR VERZINKT	1
31	732-04505	RESSORT 1.00 DIA X 3.925 LG	FINISH:PHOS AND OIL	1
32	732-0716D	RESSORT	FINISH:MTD STD 701-01006	1
33	735-05051	CAOUTCHOUC DE PEDALE DE FREIN	FINISH:SCHWARZ SIEHE ZG.	1
34	736-0272	RONDELLE .510x1.00X.060	SPEC 100015 oder SPEC-101616	1
35	736-0275	RONDELLE	FINISH:MTD SPEC-100015	2
36	736-0300	RONDELLE	FINISH:MTD SPEC-100015	3
37	736-0362	RONDELLE .320ID X 1.25 ODX .0	FINISH:SPEC-100016	1
38	736-3019	RONDELLE .531x1.062x.134:HT	FINISH:MTD SPEC-100016	1
40	738-0347	RONDELLE í EMB. .625IDx.169	FINISH:	1
41	741-0124A	ROULEMENT A BILLE	FINISH:	2
42	741-0591	BAGUE	FINISH:NATUR 941-0591	2
43	747-04815C	TIGE DE FREIN	FINISH:SPEC-100015	1
44	747-04897D-S		FINISH:LACKIERT	1
45	748-04175	SUPPORT ENTRETOISE	FINISH:GEíLT	1
46	750-04456	ENTRETOISE	FINISH:MTD SPEC-100015	1
47	750-04584	DOUILLE .375IDx.625ODx 1.34 LG	FINISH:SPEC-100015	1
48	750-04988	ENTRETOISE	FINISH:íL GEDIPPT	1
49	750-05521A		FINISH:GEíLT	2
50	756-04224	POULIE TENDEUR	BLK ECOAT,PAINT OR SPEC-100015	1
51	756-04324	POULIE TENDEUR	FINISH:SCHWARZ LACKIERT	1
52	783-05705	SUPPORT DE TRANSMISSION	FINISH:LACKIERT	1
53	783-05844	SUPPORT	FINISH:783-05844-Z 783-05844*	1
54	783-05855		FINISH:LACKIERT	1
55	783-05882		FINISH:LACKIERT 783-05882*	1
56	783-1363	PLAQUE SUPPORT	FINISH:BLAU CHROMATIEREN *	1

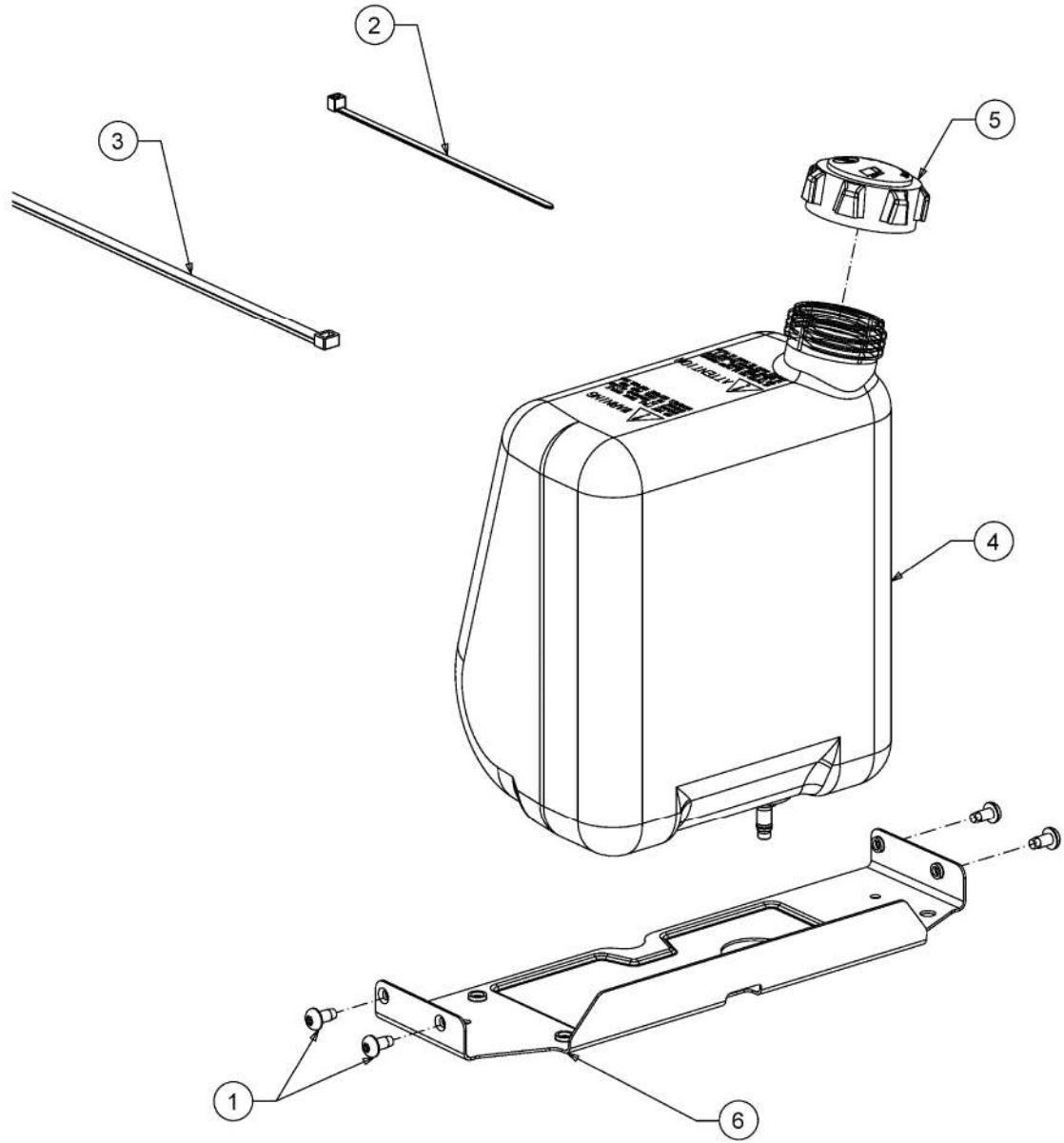

813-061066-06

# RÚservoir

Fig.	No. Pièces	DÚsignation	Numero de la norme	Nbr.
1	710-05070A	VIS	FINISH: SCHWARZ SPEC-000087	4
2	725-0157	COLLIER DE SERRAGE 3/16X0.5X7.4	MATERIAL: NYLON-SCHWARZ	1
3	726-0230	COLLIER	FINISH: SCHWARZ	1
4	751-0555B	RESERVOIR D'ESSENCE: 5.7L	FINISH: NATUR	1
5	751-0603B	BOUCHON ESSENCE	FINISH: KUNSTSTOFF SCHWARZ	1
6	783-07083A-S	SUPPORT DE RESERVOIR ESSENCE	FINISH: LACKIERT MTD QUALIT-T	1



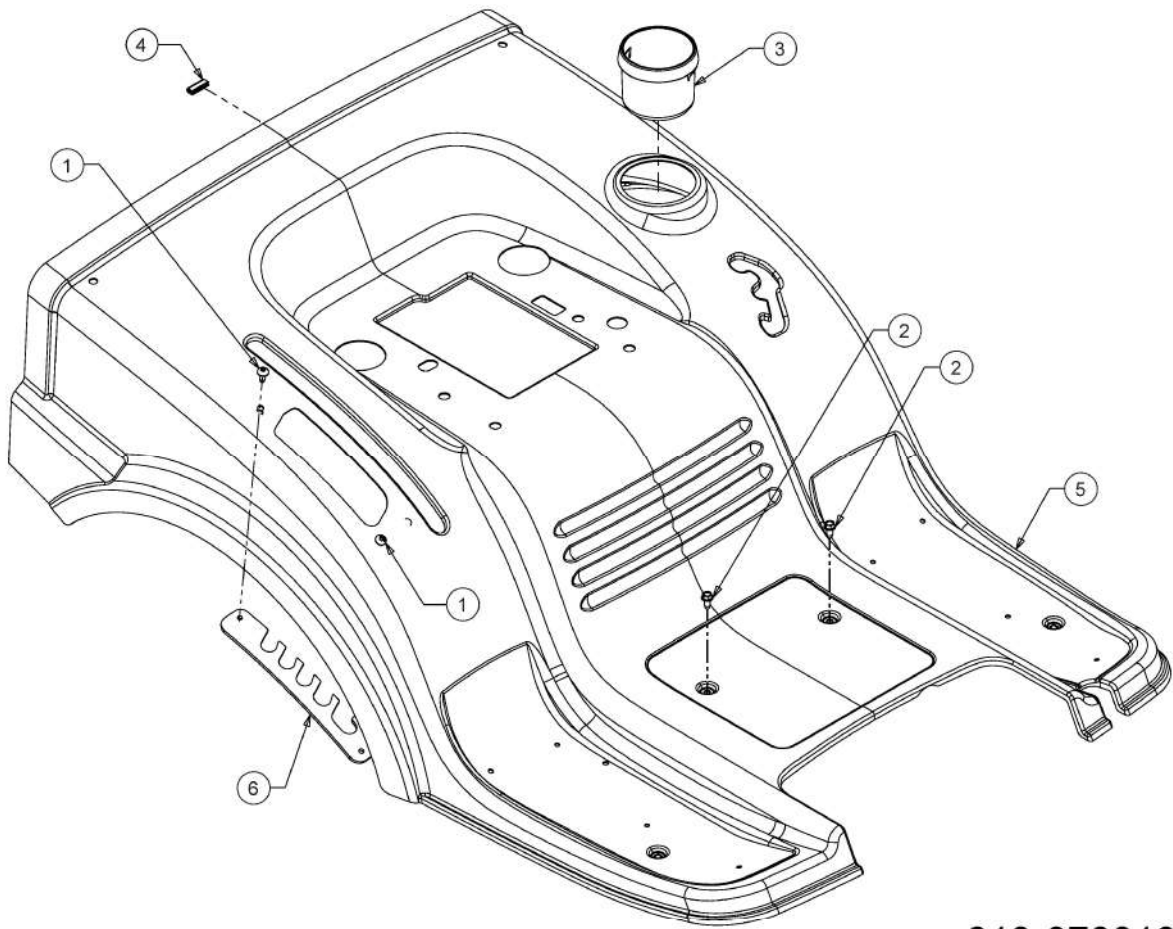

813-070010-11R

# Jupe

Fig.	No. Pièces	Désignation	Numero de la norme	Nbr.
1	710-05070A	VIS	FINISH: SCHWARZ SPEC-000087	2
2	710-0599	VIS A SIX PANS CREUX	FINISH: MTD SPEC-101617	2
3	731-04591A	PORTE GOBELET	FINISH: KUNSTSTOFF SCHWARZ	1
4	731-0511	BORDURE DE PROTECTION	FINISH: SCHWARZ, SIEHE ZG.	1
5	783-05744638	JUPE ARRIERE ROUGE MTD	MTD ROT	1
6	783-05875A	SELECTEUR HAUTEUR DE COUPE	FINISH: 783-05875A-Z 5 POS	1

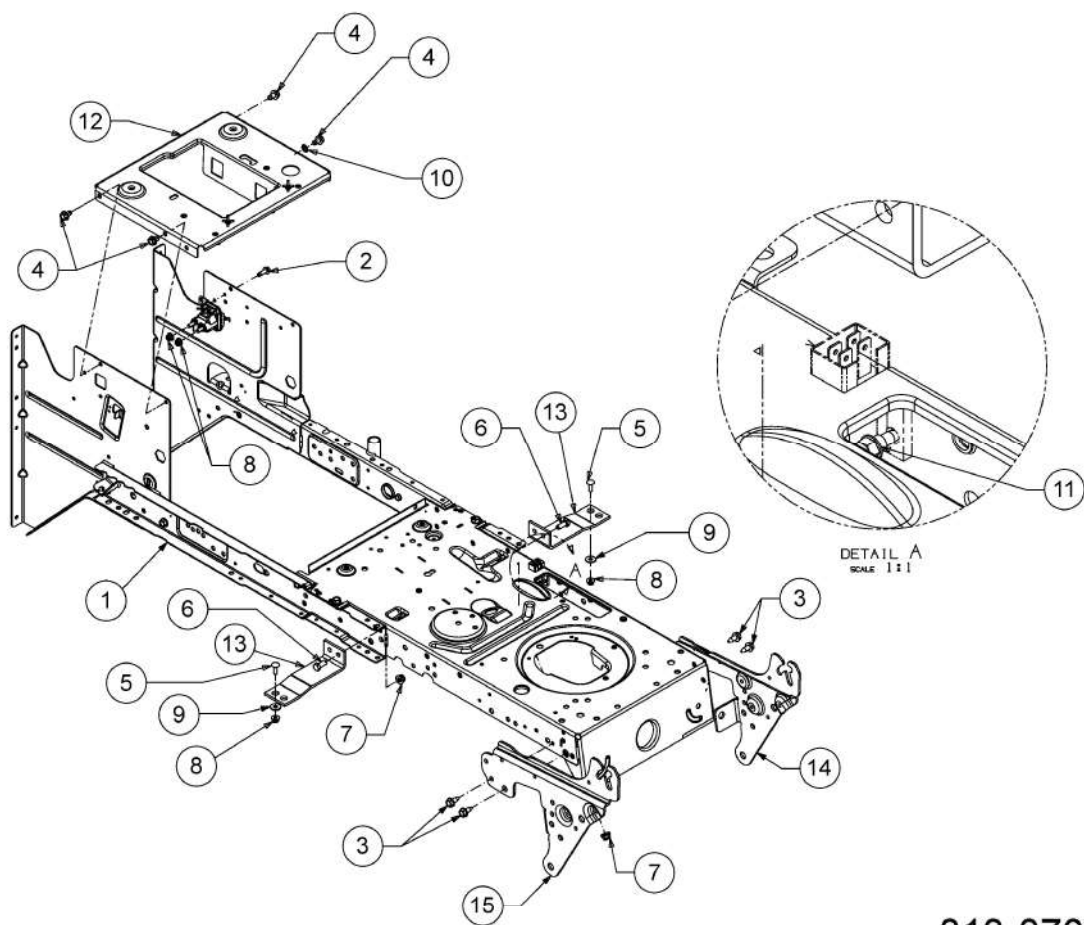

813-070082-18

# ChÔssis

Fig.	No. Pièces	DÚsignation	Numero de la norme	Nbr.
1	683-04682G-S			1
2	710-04461	VIS	FINISH:SIEHE ZG.	1
3	710-04484	VIS HEX. TT:5/16-18.:750:HXIND	FINISH:MTD SPEC-100016 TYPE 1	4
4	710-0607	VIS HEX.TT5/16-18.:500HXINDWSh	FINISH:MTD SPEC-100016 TYPE 1	4
5	710-0703	VIS	FINISH:MTD SPEC-100015	2
6	710-3008	VIS 5/16-18.:75:GR5:STD	SPEC-701-01006 or.SPEC-100015	2
7	712-04063	ECROU HEX. AVEC FLANC	FINISH:MTD SPEC-100015	3
8	712-04064	ECROU HEXAGONAL	FINISH:SPEC-100015 912-04064	4
9	736-0173	RONDELLE 281DX 74ODX.063	FINISH:MTD SPEC-100015	2
10	736-0607	RONDELLE	FINISH:MTD SPEC-100016	1
11	738-04237A	AXE EPAULE	FINISH:MTD SPEC-100016	1
12	783-04548D-S	SUPPORT DE SIEGE	SCHWARZ	1
13	783-04637637	SUPPORT	SCHWARZ LACKIERT	2
14	783-05417B-S	+TRIER DE CHARN.:+ GA. CAPOT	783-05417B-S	1
15	783-05418D-S	+TRIER DE CHARN.:+ DR. CAPOT	783-05418D-S	1

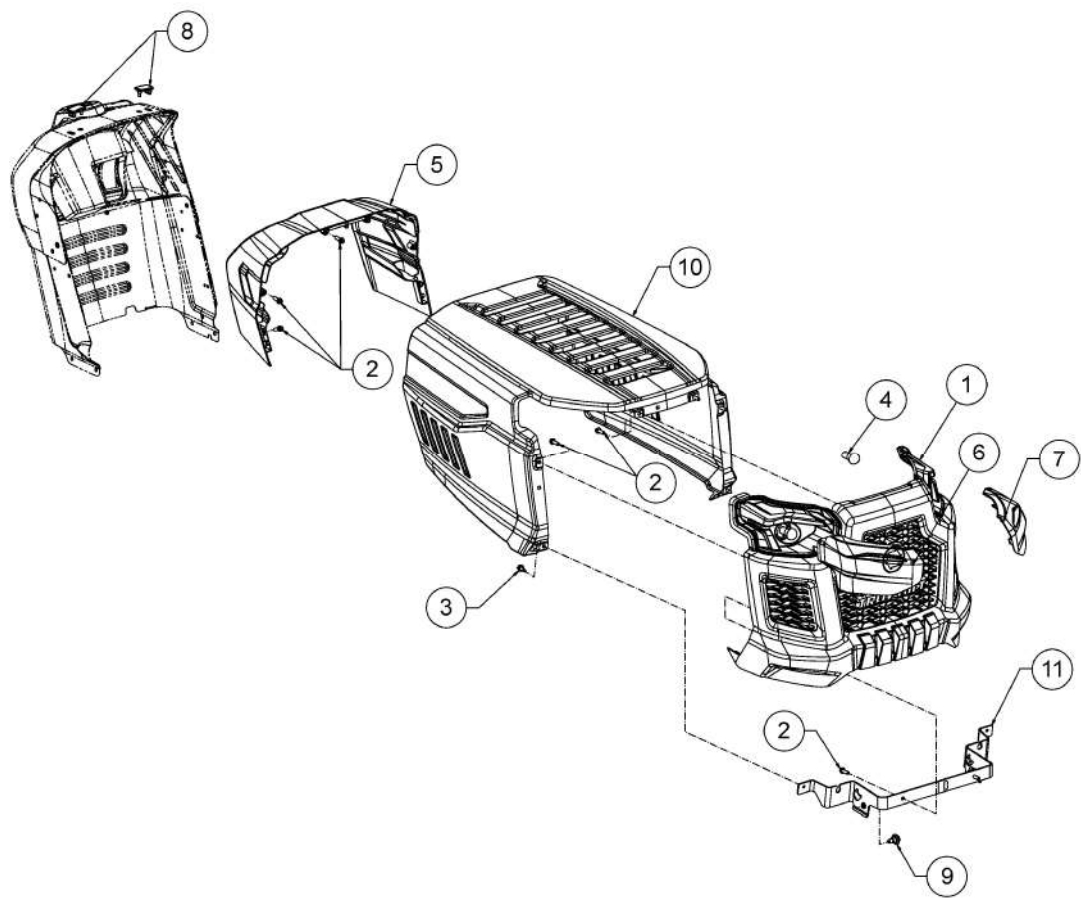

813-062321-06

## Capot de moteur

Fig.	No. Pièces	Désignation	Numero de la norme	Nbr.
1	631-05502			1
2	710-05108	VIS	FINISH:SPEC-701-01006	12
3	710-1652	VIS HEX. TT:1/4-20:.625:HXINDW	FINISH:MTD-SPEC-100016 TYPE 1	2
4	725-0963	AMPOULE ELECTRIQUE	FINISH:	2
5	731-12615			1
6	731-12657A			1
7	731-12661A			1
8	735-05199			2
9	738-04091A	VIS EPAULEE	FINISH:SPEC-100016	2
10	783-09469			1
11	783-09471			1

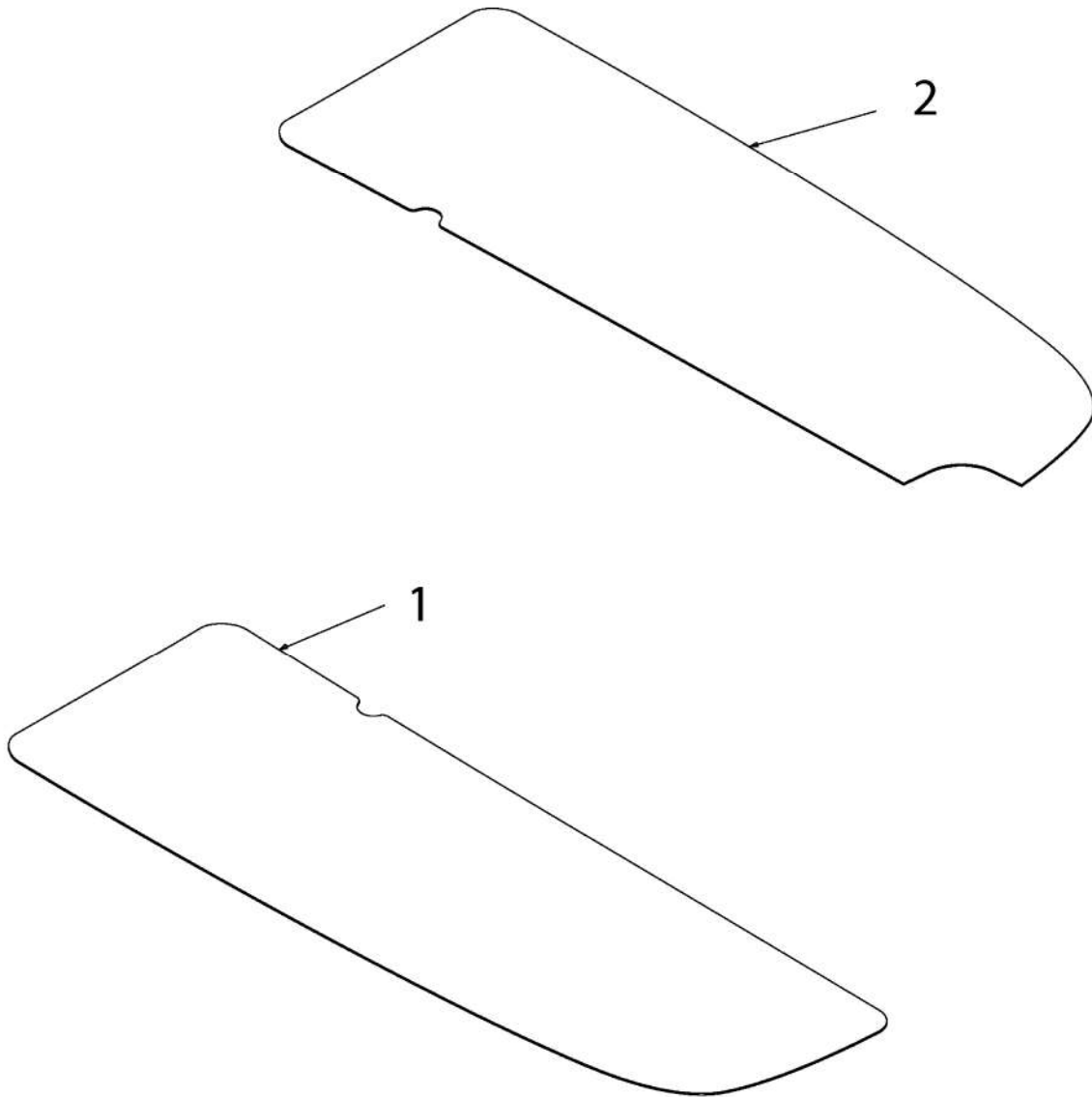

E3-02721A-01

## Marchepied garniture

Fig.	No. Pièces	Désignation	Numero de la norme	Nbr.
1	723-04025	MARCHE PIED DROITE	FARBE: SCHWARZ	1
2	723-04026	MARCHE PIED GAUCHE	FARBE: SCHWARZ	1



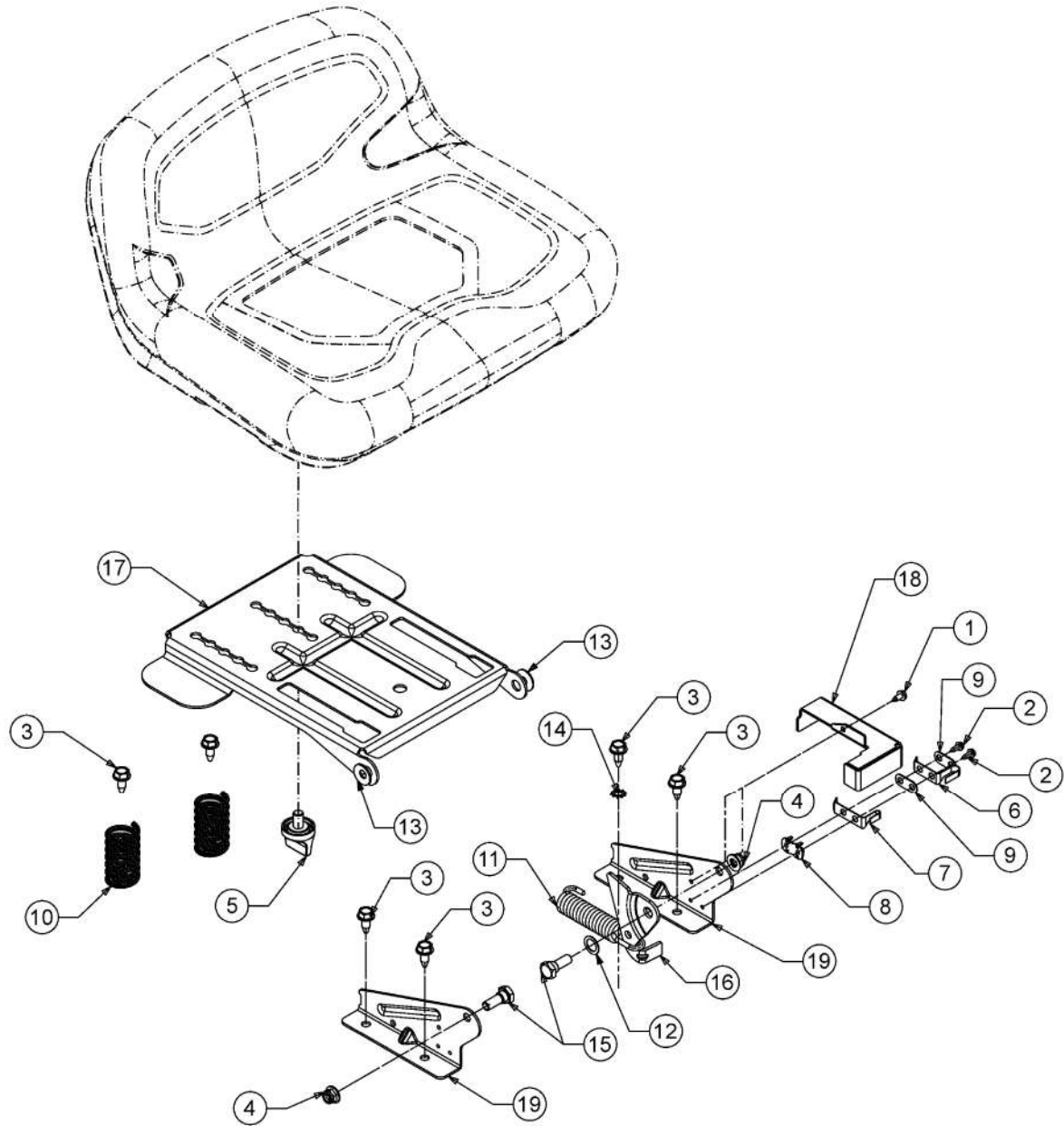

813-070788-05

# RÚglage de siége

Fig.	No. Pièces	Désignation	Numero de la norme	Nbr.
1	710-0224	VIS PARK:#10-16:0.500:HXINDWSH	FINISH:MTD SPEC-100016 TYPE 1	1
2	710-0227	VIS	FINISH:MTD SPEC-100016 TYPE 1	2
3	710-04484	VIS HEX. TT:5/16-18.:750:HXIND	FINISH:MTD SPEC-100016 TYPE 1	6
4	712-04063	ECROU HEX. AVEC FLANC	FINISH:MTD SPEC-100015	2
5	720-05164		FINISH:SCHWARZ	1
6	725-1303	RESSORT DE SURETE SIÉGE	SI.-SCHALTER SITZ:SPEC-100015	1
7	725-1439	RESSORT SURETE DE SIEGE	SI.-SCHALTER SITZ:SPEC-100015	1
8	726-0278	PLAQUE D'ISOLATION	FINISH:NATUR ODER SCHWARZ	1
9	726-0279	PLAQUE D'ISOLATION	FINISH:NATUR ODER SCHWARZ	2
10	732-0735A	RESSORT DE SIEGE	FINISH:MTD SPEC 101616	2
11	732-08282	RESSORT	732-08282	1
12	736-0108	RONDELLE	FINISH:MTD SPEC-100015	1
13	736-0242	RONDELLE CONIQUE.340X.872X.060	FINISH:MTD SPEC-100016	2
14	736-0607	RONDELLE	FINISH:MTD SPEC-100016	1
15	738-0296	AXE EPAULE	FINISH:SPEC-100015	2
16	783-0209D	SUPP. SIÉGE	FINISH:SPEC-100016	1
17	783-04081D-S	PLAQUE DE SIEGE NOIRE	SCHWARZ	1
18	783-04877A-S	PROTECTION DE SECURITES DE	SCHWARZ / 788-0637	1
19	783-1489D637	SUPPORT DE SIEGE NOIR	SCHWARZ	2

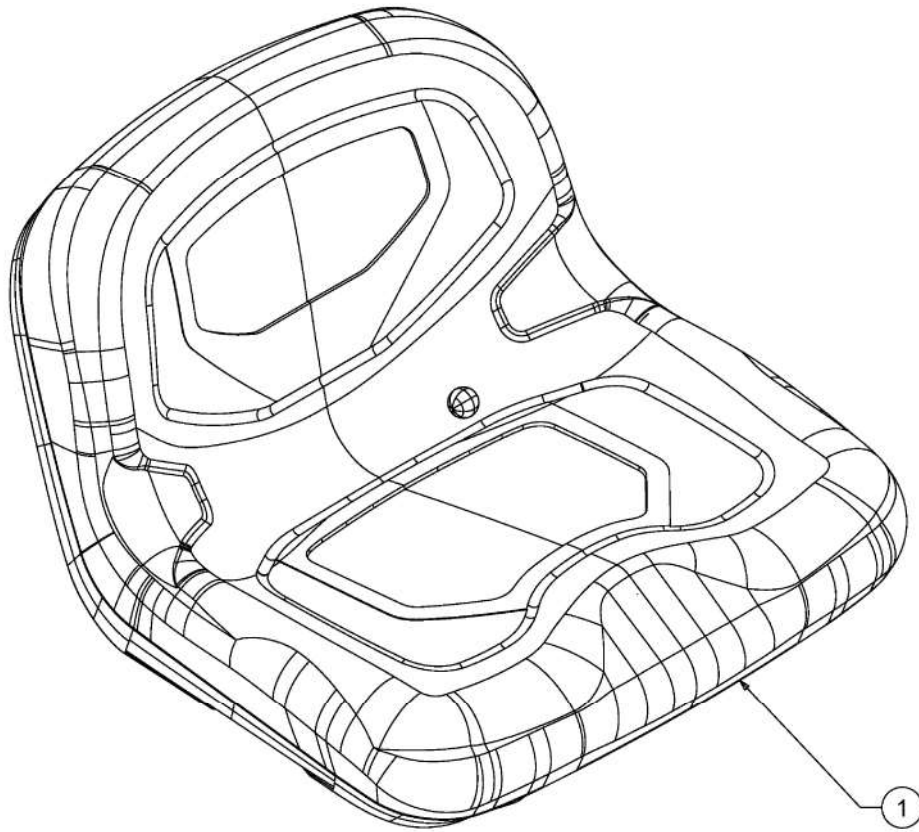

813-062983-00

# Siège

Fig.	No. Pièces	Désignation	Numero de la norme	Nbr.
1	757-05229	SIEGE	FARBE: SCHWARZ	1

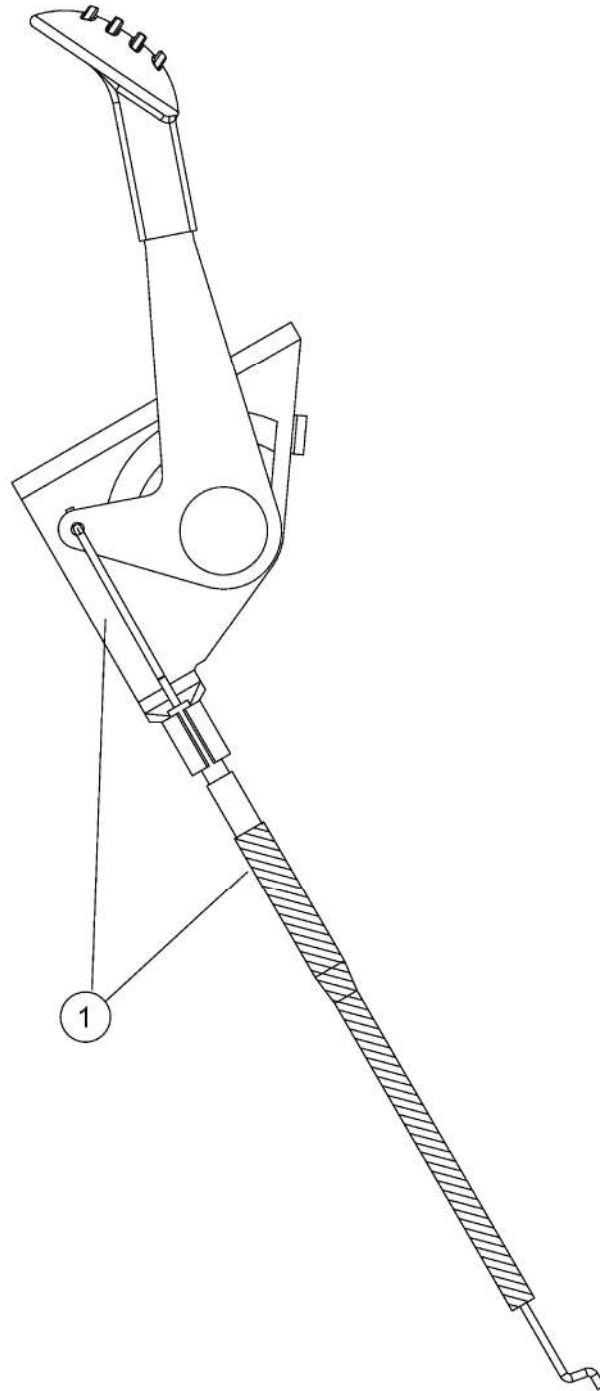

E3-11414A-01

## Cable de gaz

Fig.	No. Pièces	Désignation	Numero de la norme	Nbr.
1	746-05049A	CABLE GAZ	MIT BEDIENUNGSHEBEL	1

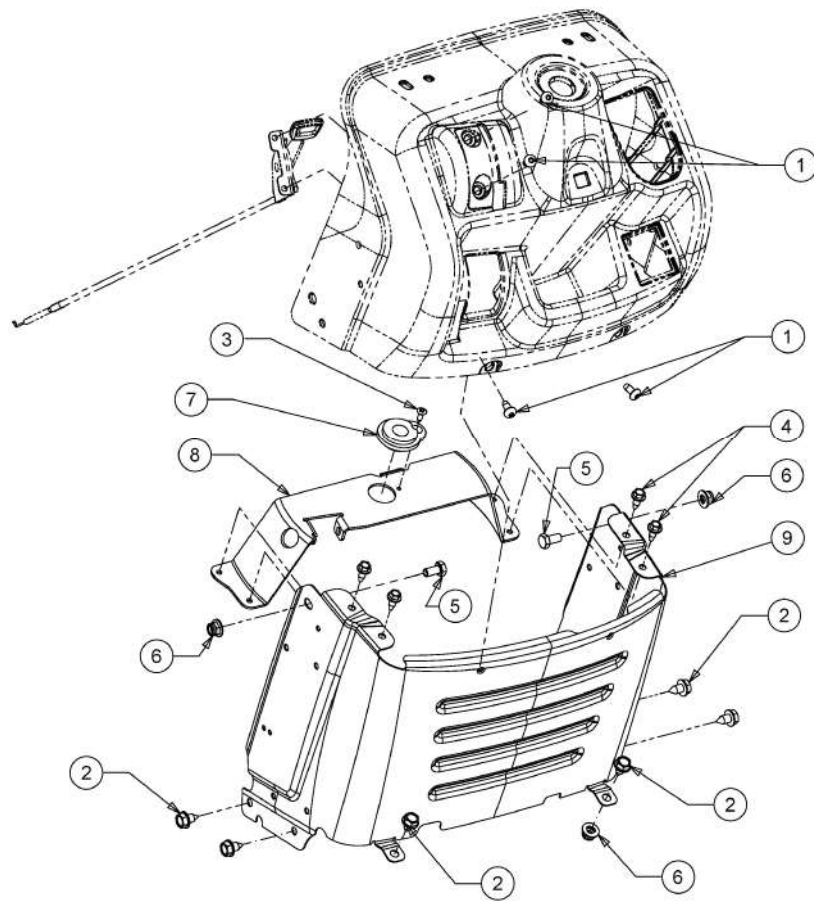

813-061151-11

## Tableau de bord

Fig.	No. Pièces	Désignation	Numero de la norme	Nbr.
1	710-05070A	VIS	FINISH: SCHWARZ SPEC-000087	4
2	710-0604A	VIS 5/16-18:0.625	FINISH: MTD SPEC-100016 TYPE 1	6
3	710-0837	VIS	FINISH: MTD SPEC-100016 TYPE 1	1
4	710-1652	VIS HEX. TT:1/4-20:.625:HXINDW	FINISH: MTD-SPEC-100016 TYPE 1	4
5	710-3025	VIS	FINISH: MTD SPEC-100015	2
6	712-04063	ECROU HEX. AVEC FLANC	FINISH: MTD SPEC-100015	4
7	741-0587	SUPPORT	FINISH: NATUR	1
8	783-06785C-S	SUPPORT TABLEAU DE BORD	SCHWARZ	1
9	783-06811F-S	TABLEAU DE BORD INFERIEUR		1



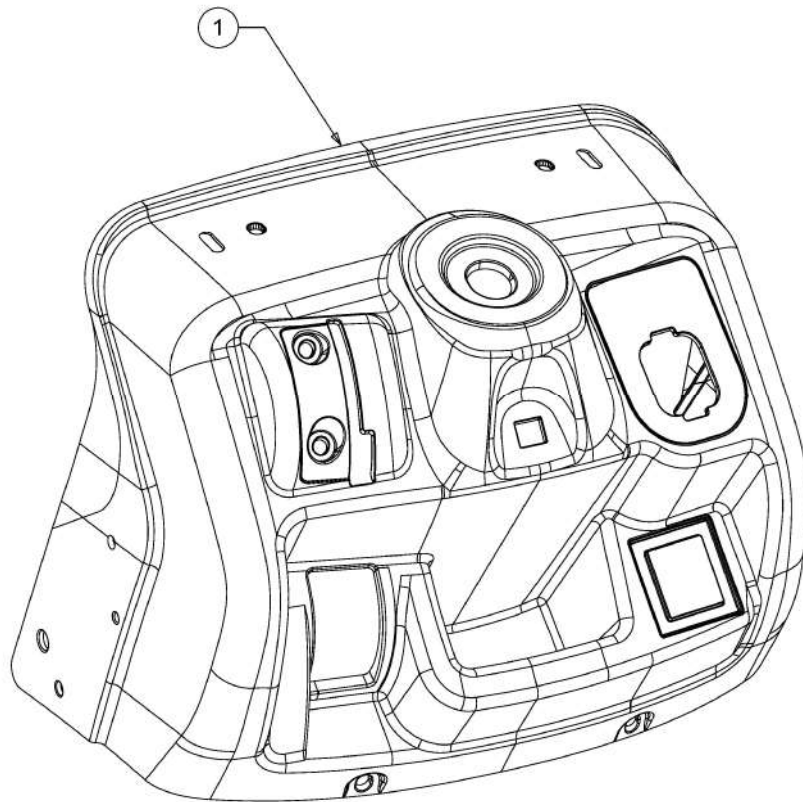

731-08542C-02

## Tableau de bord piPce supÚriure

Fig.	No. PiPces	DÚsignation	Numero de la norme	Nbr.
1	731-08542C	TABLEAU DE BORD	NRMC:FINISH KUNSTSTOFF SCHWARZ	1

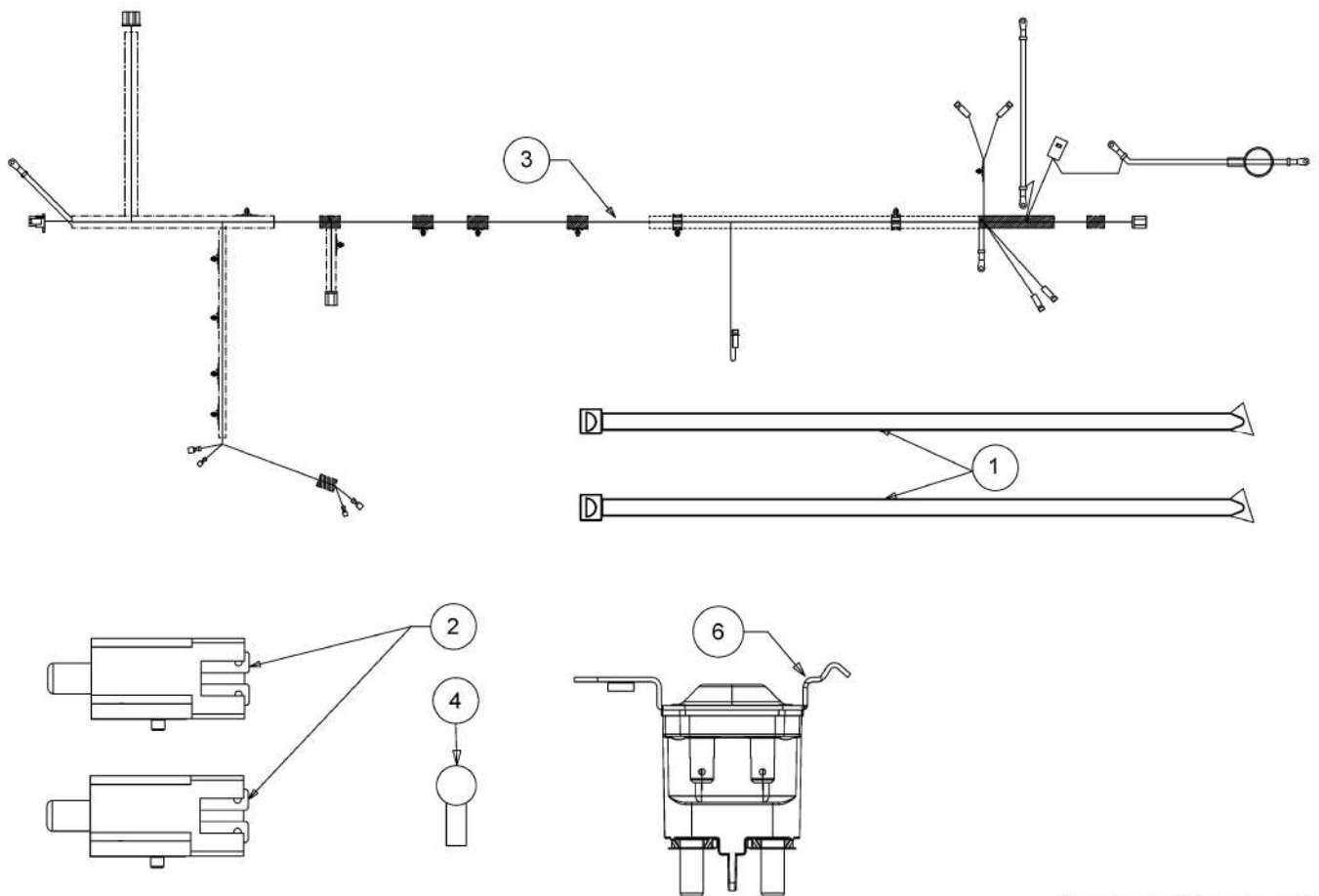

813-070819-00

# Assortiment Úlectrique

Fig.	No. PiPces	DÚsignation	Numero de la norme	Nbr.
1	725-0157	COLLIER DE SERRAGE3/16X0.5X7.4	MATERIAL:NYLON-SCHWARZ	4
2	725-04363	SECURITE EMBRAYAGE	FINISH:SIEHE ZG.	2
3	725-18168			1
4	725-3237	COUVERCLE POLE / ROUGE	BATTERIE FINISH:ROT	1
6	725-06153A	RELAIS DE DEMARRAGE	(4 FUNKTIONEN )	1

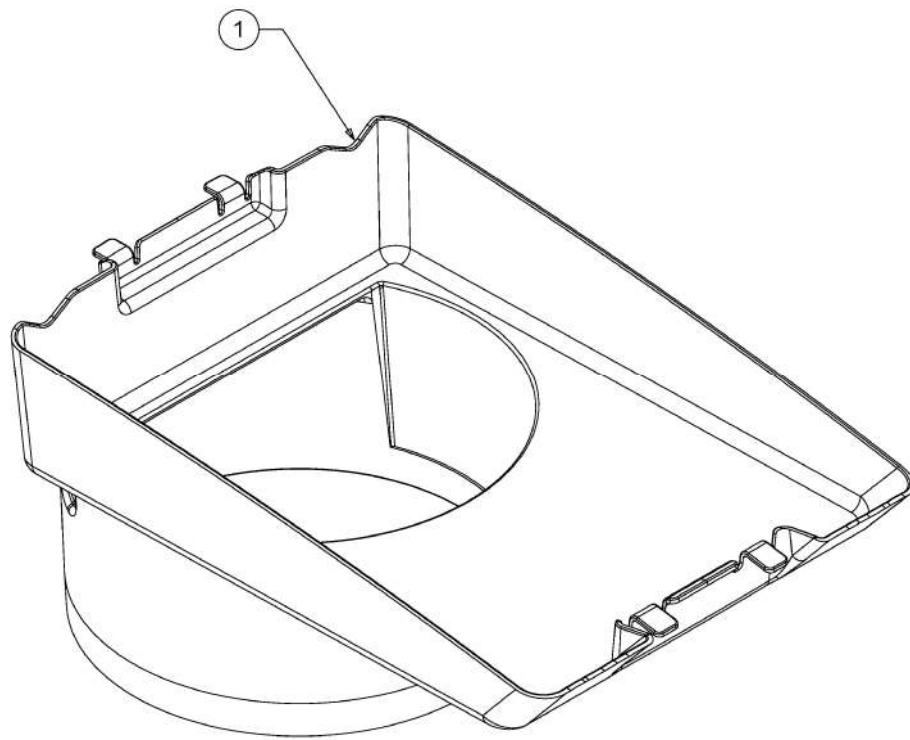

731-12705A-01

# Conduit air

Fig.	No. Pièces	Désignation	Numero de la norme	Nbr.
1	731-12705A			1

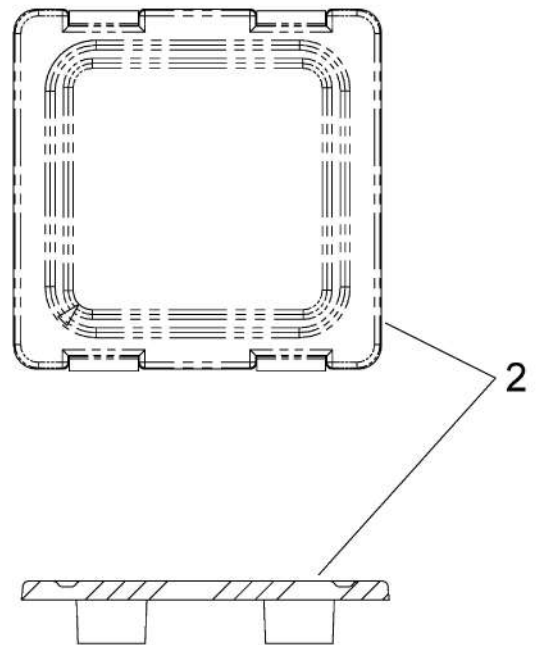
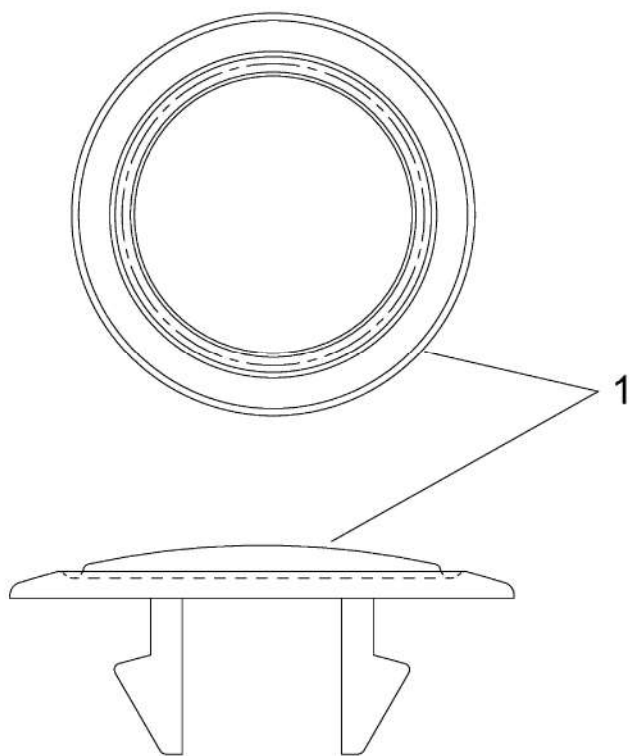

E3-06862B-01

## Couvercle de protection du tableau de bord

Fig.	No. Pièces	Désignation	Numero de la norme	Nbr.
1	731-05265		FINISH: SCHWARZ	1
2	731-05232	CACHE AMPERMETRE	FINISH: KUNSTSTOFF SCHWARZ	1



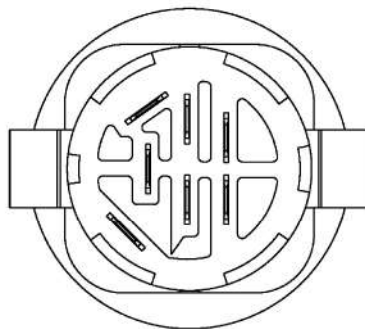
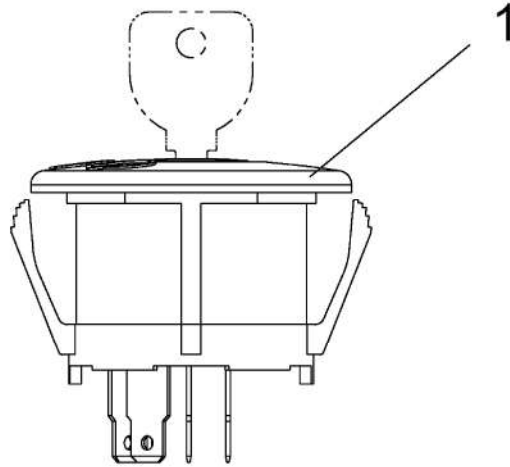
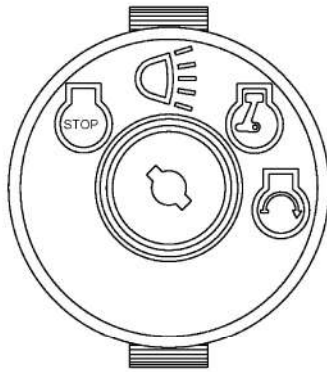

E3-04007A-01

# Contacteur

Fig.	No. Pièces	Désignation	Numero de la norme	Nbr.
1	725-1741	CONTACTEUR A CLE	FINISH: 925-1741	1

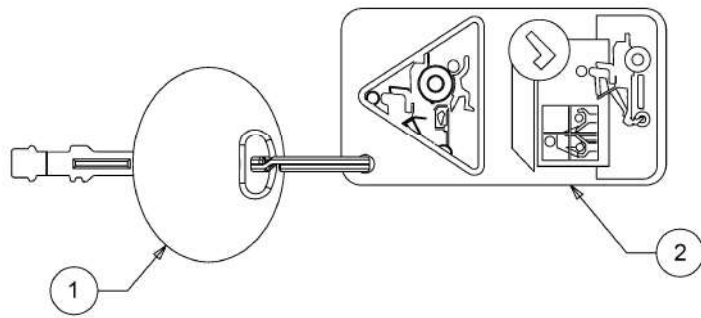

E3-10900A-01

# CIÚ

Fig.	No. Píeces	DÚsignation	Numero de la norme	Nbr.
1	725-1745A	CLE UNIVERSEL	FINISH:	1
2	731-19013			1

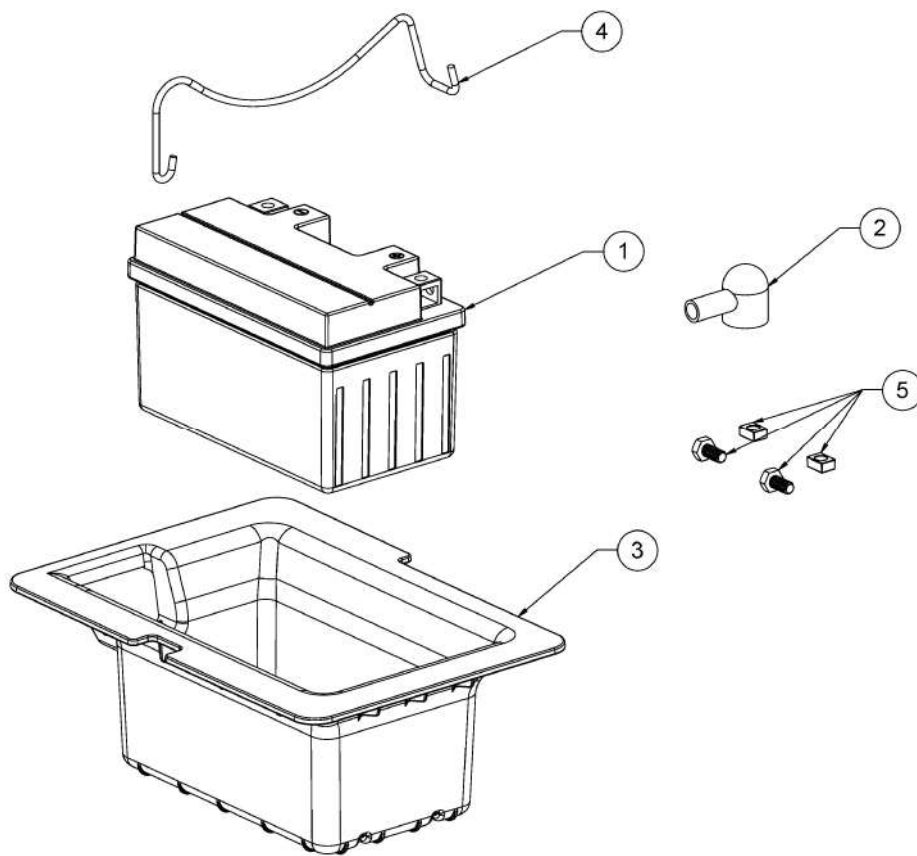

813-064058-02

# Batterie

Fig.	No. Pièces	Désignation	Numero de la norme		Nbr.
1	725-17136	BATTERIE AGM 7AH	725-17136		1
2	725-3237	COUVERCLE POLE / ROUGE	BATTERIE	FINISH:ROT	1
3	731-27025				1
4	747-11690				1
5	753-11253				1