

HORSE 105T-R

13AJ71BN609

2023

Table-No.:	Description
E3-03996B-01	Palier 618-04657A
E3-01670D-01	Palier 618-0609D / 918-0609D
813-070178-08	"Couvercles de protection plateau de coupe N (41"/105cm)"
813-070153-04	Poulie moteur
813-070003-40	"Plateau de coupe N (41"/105cm)"
813-070004-18	Dispositif de rÚception de l'herbe
813-070188-10	Relevage plateau de coupe
813-070181-02	TuyPre nettoyage Faucheuse
813-070806-05	Axe avant
813-062012-00	Enjoliveur
813-061064-09	Frein d'arrÚt
813-070159-05OG	Roues, fusÚes d'essieu
813-070017-19	SystPme direction
813-010305-00	Volant
813-070152-38	Bo Úte de vitesse hydrostatique, Courroie, Pedales Ó partir
E3-11412A-01	Moteur
813-062278-03	Protection thermique
813-062348-10	Accessoires moteur
813-061066-06	RÚervoir
E3-04542B-01	Pare-chocs
813-070179-08R	Jupe
813-070155-19	ChÓssis
813-062321-06	Capot de moteur
E3-02721A-01	Marchepied garniture
813-070788-05	RÚglage de siPge
813-062983-00	SiPge
E3-11402A-01	Cable de gaz
E3-08094A-01	Commande de choke
813-061151-11	Tableau de bord
731-09942A-02	Tableau de bord piPce supÚrieure
813-070820-01	Assortiment Úlectrique
731-12705A-01	Conduit air
E3-11403A-01	Contacteur
813-064059-02	Batterie

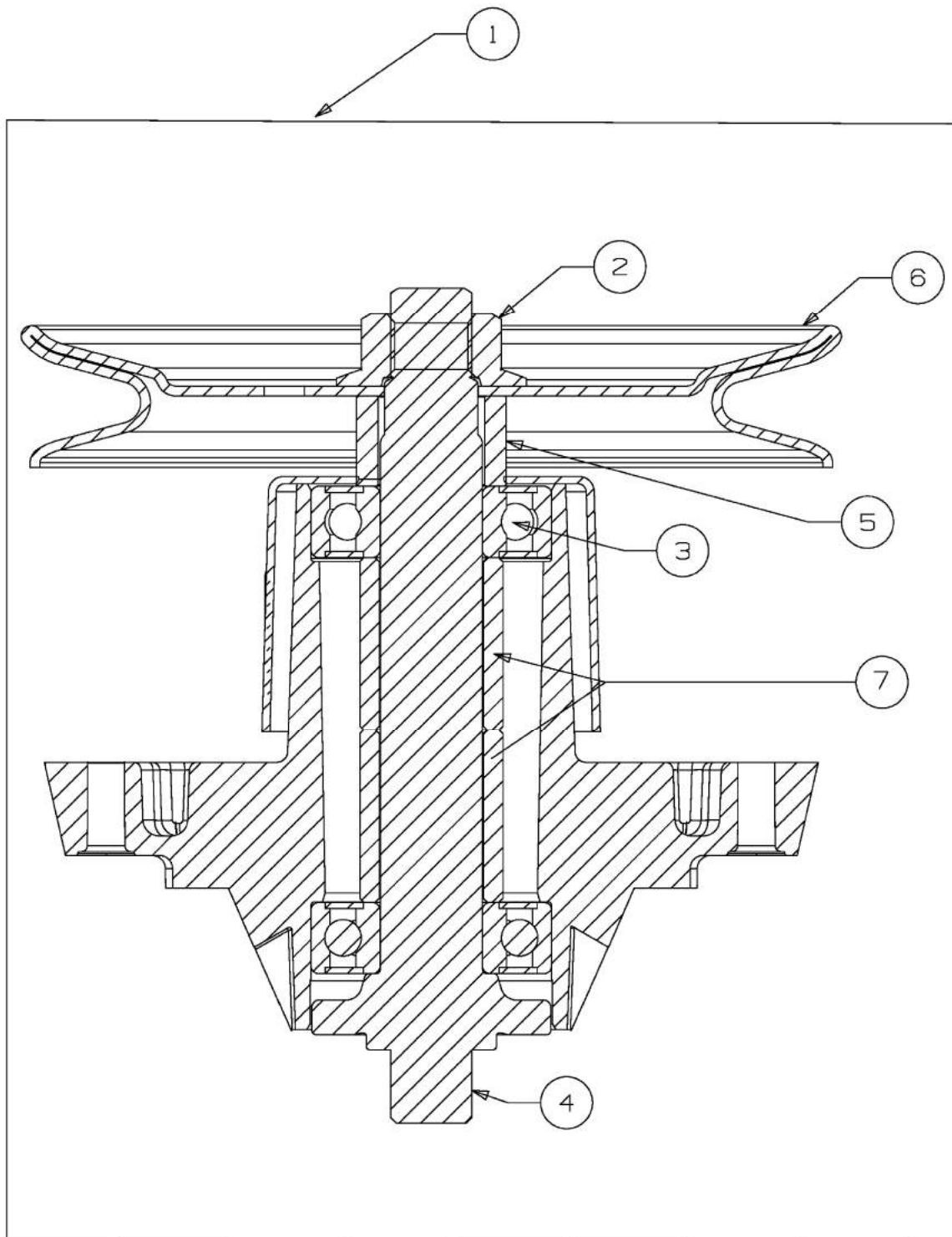

E3-03996B-01

Palier 618-04657A

Fig.	No. Pièces	Désignation	Numero de la norme	Nbr.
1	918-04657A	PALIER DE LAME COMPLET	KEILRIEMENSCHLEIBE 6.3 DIA	1
2	712-0417A	_CROU HEX. AV. FLANC: 5/8-18	FINISH:MTD STD 701-01000	1
3	741-0919A	ROULEMENT A BILLES	FINISH:	2
4	738-1010A	AXE DE PALIER 5.75 LG	FINISH:GEILT 618-0324A	1
5	748-04302	ENTRETOISE	FINISH:GEILT	1
6	756-1227	POULIE DE PALIER DE LAME	FINISH:SIEHE ZG.	1
7	750-1000	ENTRETOISE:.80x1.10x1.330	FINISH:GEILT	2

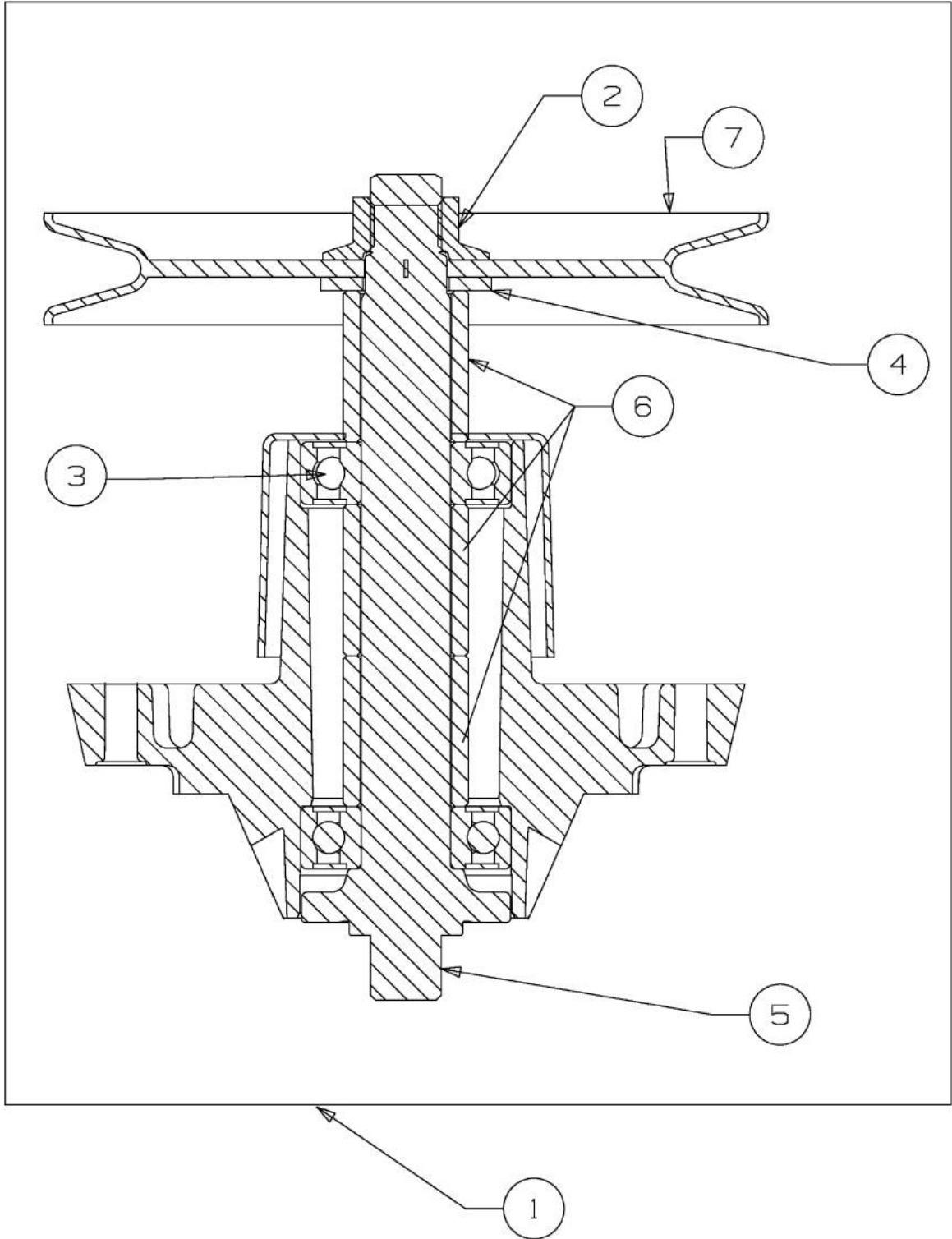

E3-01670D-01

Palier 618-0609D / 918-0609D

Fig.	No. Pièces	Désignation	Numero de la norme	Nbr.
1	918-0609D	PALIER DE LAME COMPLET	RIEMENSCHLEIBE	1
2	712-0417A	_CROU HEX. AV. FLANC: 5/8-18	FINISH:MTD STD 701-01000	1
3	741-0919A	ROULEMENT A BILLES	FINISH:	2
4	736-0315	RONDELLE FL	FINISH:STD SPEC-100015	1
5	738-1128	AXE DE PALIER DE LAMES:6.58"	FINISH:GEILT	1
6	750-1000	ENTRETOISE: .80x1.10x1.330	FINISH:GEILT	3
7	756-1218	POULIE DE PALIER DE LAME	Ê6.482xÊ.5625:FINISH SIEHE ZG.	1

"Couvercles de protection plateau de coupe N (41"/105cm)"

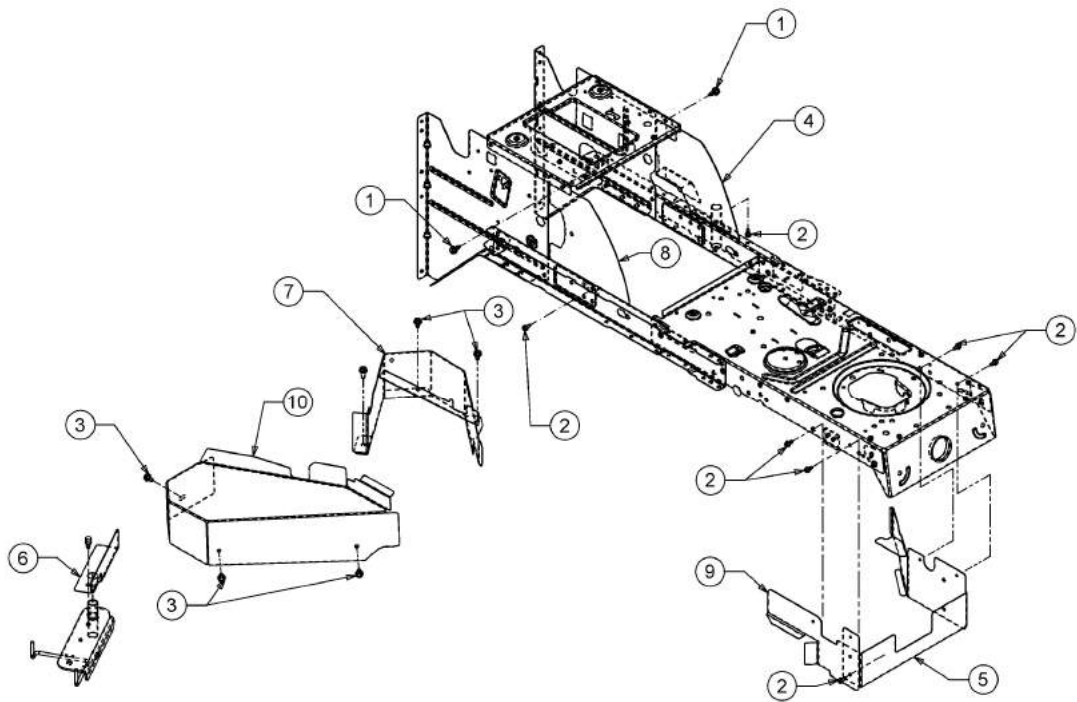

813-070178-08

"Couvercles de protection plateau de coupe N (41"/105cm)"

Fig.	No. Pièces	Désignation	Numero de la norme	Nbr.
1	710-04484	VIS HEX. TT:5/16-18:.750:HXIND	FINISH:MTD SPEC-100016 TYPE 1	2
2	710-0599	VIS A SIX PANS CREUX	FINISH:MTD SPEC-101617	8
3	710-0607	VIS HEX.TT5/16-18:.500HXINDWSh	FINISH:MTD SPEC-100016 TYPE 1	5
4	783-05085C-S	CARTER DE PROTECTION GAUCHE	FINISH:LACKIERT	1
5	783-06002A-S	PROTECTION DE POULIE PTO	SCHWARZ	1
6	783-06004637	PROTECTION DE POULIE DROITE	FINISH:SCHWARZ	1
7	783-06005A-S	COUVERCLE DE PROT.:LT-5:N-DECK	FINISH: SCHWARZ GEPULVERT	1
8	783-06676637	PROTECTION DROITE	SCHWARZ	1
9	783-10469637		783-10469637	1
10	783-10472637	COUVERCLE	783-10472637	1

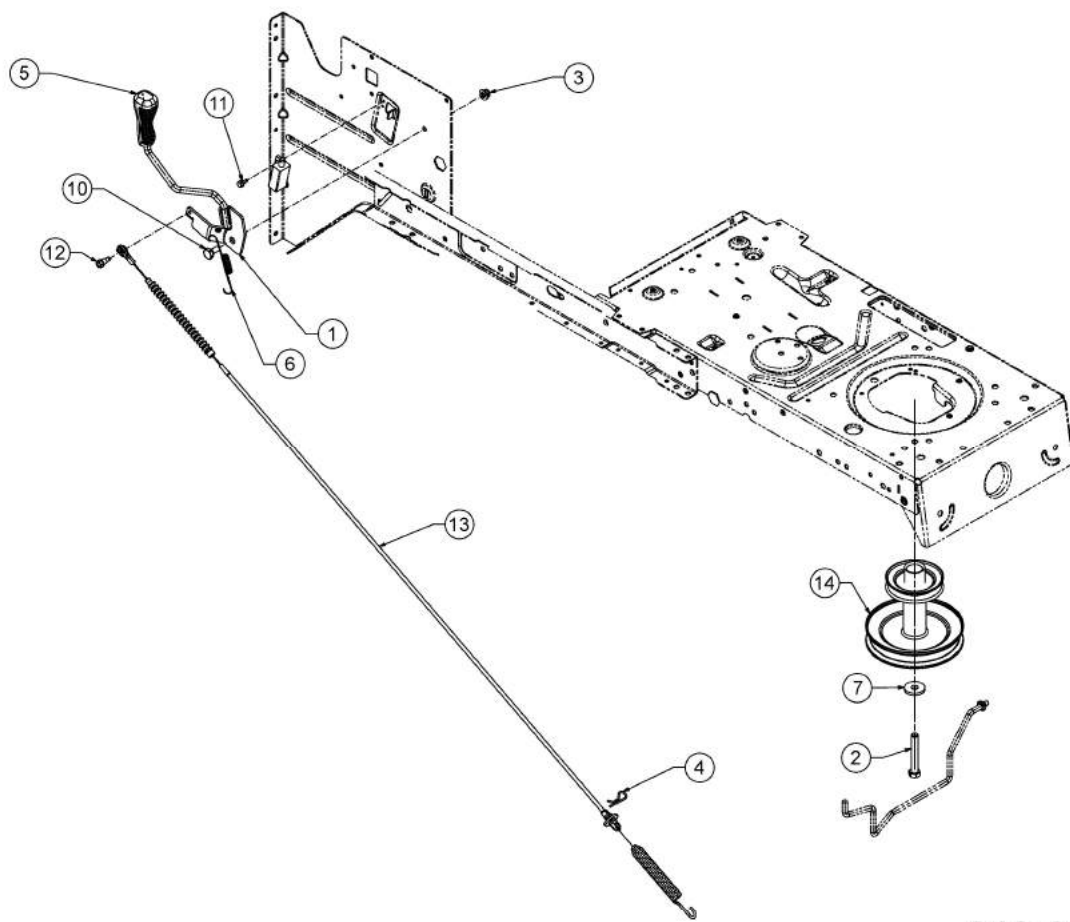

813-070153-04

Poulie moteur

Fig.	No. Pièces	Désignation	Numero de la norme	Nbr.
1	647-04239B			1
2	710-04377	VIS A SIX PANS CREUX	FINISH:MTD SPEC-100015	1
3	712-04063	ECROU HEX. AVEC FLANC	FINISH:MTD SPEC-100015	1
4	714-0145	GOUPILLE	FINISH:SPEC-701-01006	1
5	720-04049A	POIGNEE PLASTIQUE	FINISH:SCHWARZ	1
6	732-05376	RESSORT LEVIER PTO	FINISH:MTD SPEC-701-01006	1
7	736-0322	RONDELLE .450 X 1.250 X .164	FINISH:SPEC-100016 936-0322	1
10	738-0140	VIS A EP.:.435 x.178-5/16 x.56	FINISH:MTD SPEC-100015	1
11	738-04237A	AXE EPAULE	FINISH:MTD SPEC-100016	1
12	738-04425	AXE EPAULE	FINISH:MTD SPEC-100016	1
13	746-05436	CABLE D EMBRAYAGE	VERKAPSELT	1
14	756-04427	POULIE MOTEUR	HYDRO:FINISH SPEC 100015	1

"Plateau de coupe N (41"/105cm)"

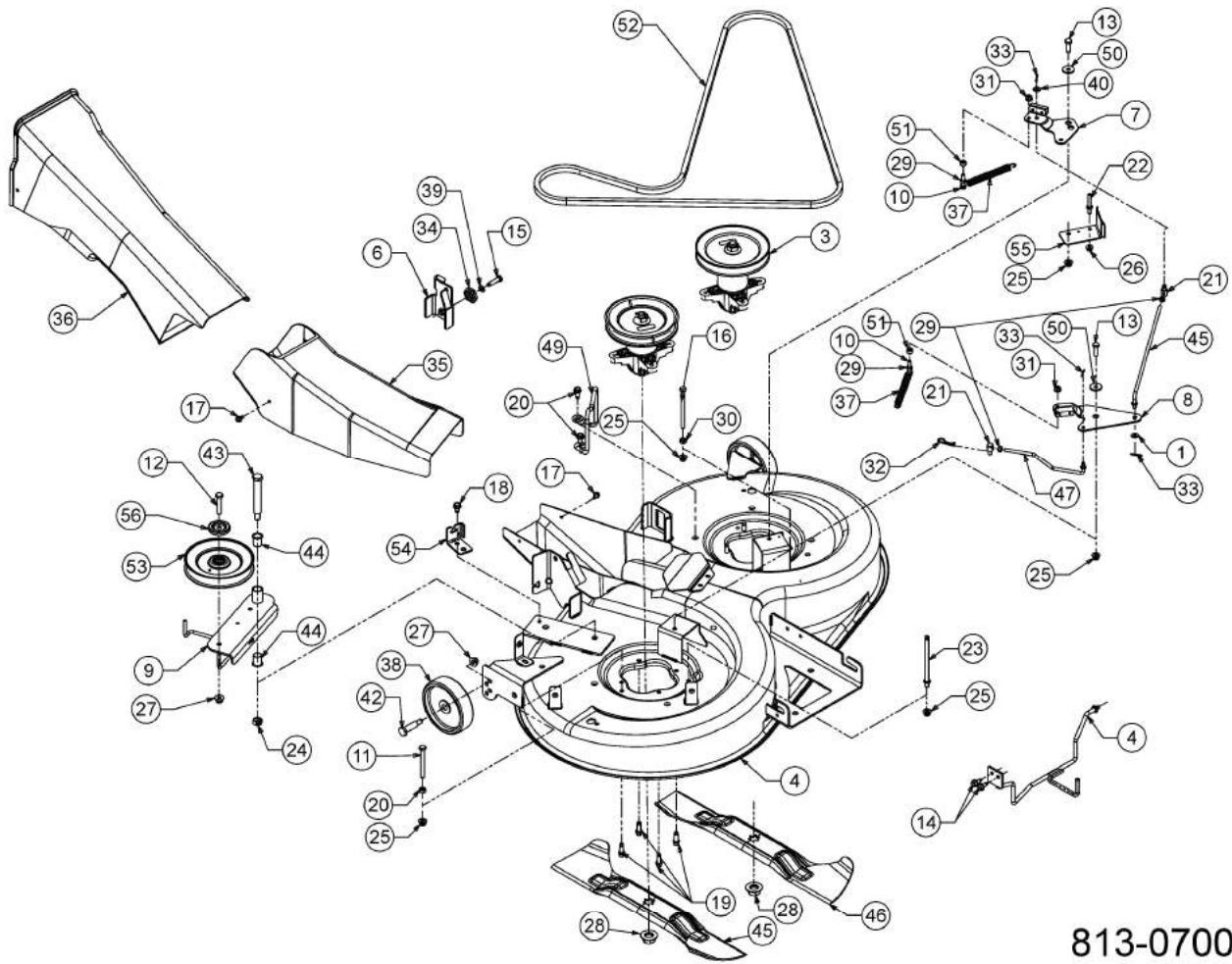

813-070003-40

"Plateau de coupe N (41"/105cm)"

Fig.	No. Pièces	Désignation	Numero de la norme	Nbr.
1	1751	RONDELLTE	1751	1
2	918-04657A	PALIER DE LAME COMPLET	KEILRIEMENSCHLEIBE 6.3 DIA	1
3	918-0609D	PALIER DE LAME COMPLET	RIEMENSCHLEIBE	1
4	647-04143A		SCHWEISST:VERZINKEN+VERSIEGEL*	1
5	683-04390G-S	CARTER DE COUPE LT 5 105CM	SCHWARZ LACKIERT	1
6	683-04396637	SUPPORT	SCHWARZ	1
7	683-04409		LT5: NIETTEIL	1
8	683-04417	FREIN DE LAME	LT5: NIETTEIL	1
9	683-04420637	SUPPORT POULIE TENDEUR	SCHWARZ LACKIERT	1
10	710-0106	VIS HEX. 1/4-20:1.25:GR5:SPEC	FINISH:MTD SPEC-100015	2
11	710-0189	VIS HEX.:5/16-18x3.00:GR5:STD	FINISH:SPEC-100015 910-0189	1
12	710-0347	VIS HEX. 3/8-16:1.75:GR5:STD	FINISH:MTD SPEC-100015	1
13	710-0376	VIS HEX.:5/16-18:1.00:GR5:STD	FINISH:MTD SPEC 701-01006	2
14	710-04484	VIS HEX. TT:5/16-18:.750:HXIND	FINISH:MTD SPEC-100016 TYPE 1	2
15	710-0528	VIS HEX. 5/16-18:1.25:GR5:STD	FINISH:SPEC-100015 910-0528	1
16	710-05410	VIS	710-05410	1
17	710-0599	VIS A SIX PANS CREUX	FINISH:MTD SPEC-101617	2
18	710-0607	VIS HEX.TT5/16-18:.500HXINDWSh	FINISH:MTD SPEC-100016 TYPE 1	1
19	710-06322	VIS	FINISH:SPEC-100016 TYPE 1	8
20	710-1260A	VIS TT:5/16-18:.750	FINISH:SPEC-100016 TYPE 1	2
21	711-0736	AXE	FINISH:MTD SPEC-100015	2
22	711-0993	GUIDE COURROIE	FINISH:701-01006 911-0993	1
23	711-1044A	GUIDE COURROIE	FINISH:PHOS AND OIL	1
24	712-0290	ECROU 7/16-14	FINISH:MTD SPEC-100015	1
25	712-04063	ECROU HEX. AVEC FLANC	FINISH:MTD SPEC-100015	5
26	712-04064	ECROU HEXAGONAL	FINISH:SPEC-100015 912-04064	1
27	712-04065	ECROU HEXAGONAL	FINISH:SPEC-100015 912-04065	3
28	712-05134	ECROU	FINISH:MTD SPEC-100015+WAX	2
29	712-3006	ECROU HEXAGONAL	FINISH:SPEC-100015	4
30	712-3010	ECROU HEX. 5/16-18:GR5	FINISH:MTD SPEC-100015	2
31	712-3027	ECROU HEXAGONAL 1/4-20:GRF	FINISH:MTD SPEC-100015	2
32	714-0145	GOUPILLE	FINISH:SPEC-701-01006	1
33	714-0507	GOUPILLE FENDUE 3/32 X .750	FINISH:MTD SPEC-100015	3
34	717-04074	PIGNON HAUTEUR PLATEAU	PHOS & SPEC-100015 917-04074	1
35	731-06251	CANAL D'EJECTION INFERIEUR	FINISH:SCHWARZ	1
36	731-06252	CANAL D'EJECTION SUPERIEUR	FINISH:SCHWARZ	1
37	732-0604A	RESSORT	FINISH:PHOS AND OIL	2
38	734-06265	ROULETTE DE PLATEAU	FINISH:KUNSTSTOFF SCHWARZ	2
39	736-0119	RONDELLE	FINISH:MTD SPEC-100016	2
40	736-0264	RONDELLE: .330 x.630 x.0635	FINISH:SPEC-100015 936-0264	1
42	738-0373	VIS A EPAULE .496x1.525:3/8-16	FINISH:MTD SPEC-100015	2
43	738-0476	VIS A EPAULE .625x3.50:7/16-14	FINISH:SPEC-100015	1
44	741-0591	BAGUE	FINISH:NATUR 941-0591	2
45	742-04080	LAME DROITE	STAR BAG:W-RMEBEHANDELT	1
46	742-04081	LAME GAUCHE	STAR BAG:W-RMEBEHANDELT	1
47	747-04776	TIGE DE FREIN	FINISH:MTD SPEC-100015	1
48	747-04781A	TIGE DE FREIN	MTD SPEC-101616 (YELLOW ZINC)	1
49	747-04840A	GUIDE COURROIE	FINISH:747-04840A-Z	1
50	748-0234	RONDELLE EPAULEE	FINISH:ROSTPREVENTION	2
51	750-05381	ENTRETOISE	FINISH:IN ÍL SAE 30 GEDIPPT	2
52	754-04174	COURROIE DE COUPE	FINISH:	1
53	756-04050	POULIE DE COURR. TR. È 6.0"DIA	KUGELGELAGERT:SCHWARZ LACKIERT	1
54	783-04740637	SUPPORT	SCHWARZ LACKIERT	1
55	783-05868A-S			1
56	783-08389	PROTECTION DE POULIE	FINISH:PLAIN	1

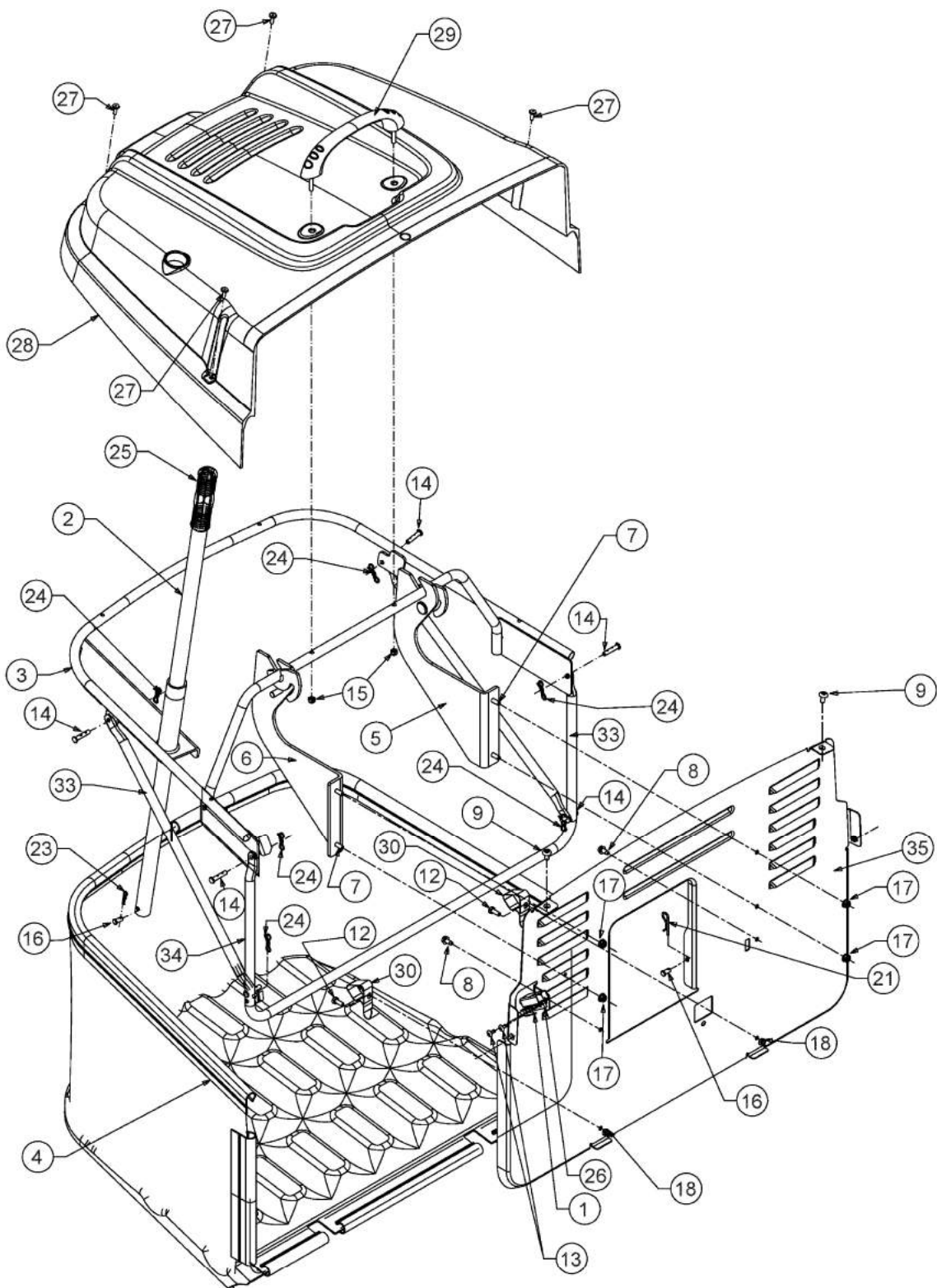

813-070004-18

Dispositif de rÚception de l'herbe

Fig.	No. PiPces	DÚsignation	Numero de la norme	Nbr.
1	17962	PLAQUE DE SUPP. P. COMMUTATEUR	FINISH:WIE GESTANZT	1
2	649-04052637	BRAS DE RELEVAGE BAC	SCHWARZ LACKIERT	1
3	649-04076B-S	ARMATURE DE BAC	SCHWEISSTEIL:FINISH LACKIERT	1
4	664-04085A	TOILE BAC 200 L	LT-5:FINISH SCHWARZ	1
5	683-04421637	SUPPORT DE BAC GAUCHE	SCHWARZ	1
6	683-04422637	SUPPORT DE BAC DROITE	SCHWARZ	1
7	710-04666	VIS HEXAGONALE	FINISH:MTD SPEC-100015	4
8	710-0599	VIS A SIX PANS CREUX	FINISH:MTD SPEC-101617	2
9	710-1017	VIS	FINISH:MTD SPEC-100016	2
12	710-0751	VIS HEX.: 1/4-20:.620:GR5:STD	FINISH:SPEC-100015	2
13	710-1760	VIS	PHOS & OIL (öhnlich 710-0779A)	2
14	711-04138	GOUJON í_PINGLER .25DIAX1.25L	FINISH:MTD SPEC-100015	6
15	712-0691	ECROU HEXAGONAL	MTD SPEC-100015 24.1426.14	2
16	711-0701	GOUJON	FINISH:MTD SPEC-100015	3
17	712-04064	ECROU HEXAGONAL	FINISH:SPEC-100015 912-04064	4
18	712-0324	ECROU HEX.:1/4-20:GR8:NYLON	FINISH:701-01000	2
21	714-0145	GOUPILLE	FINISH:SPEC-701-01006	2
23	714-04033	GOUPILLE FENDUE .072 x.92 LG	FINISH: MTD SPEC-100016	1
24	714-04040	GOUPILLE	FINISH:ASTM F1941 FE/ZN 3AN	6
25	720-0204	POIGNEE:1.0 ID x 4.7 LG	FINISH:SCHWARZ	1
26	725-04039	SECURITE	FINISH:GRAY/BLACK 925-04039	1
27	728-04044	RIVET	W_RTH #093614816	4
28	731-06106	COUVERCLE DE BAC	FINISH:KUNSTSTOFF SCHWARZ	1
29	731-06163	POIGNEE	FINISH:SCHWARZ	1
30	732-0838A	RESSORT CLIPS DE BAC	VERSCHLUSS:FINISH SPEC-100015	2
33	749-04108637	BARRE LAT BAC 250 LITRE	500 MR SCHWARZ LACKIERT	2
34	749-04418637	ARMATURE DE BAC	SCHWARZ	1
35	783-05731637	PLAQUE ARRIERE	SCHWARZ LACKIERT	1

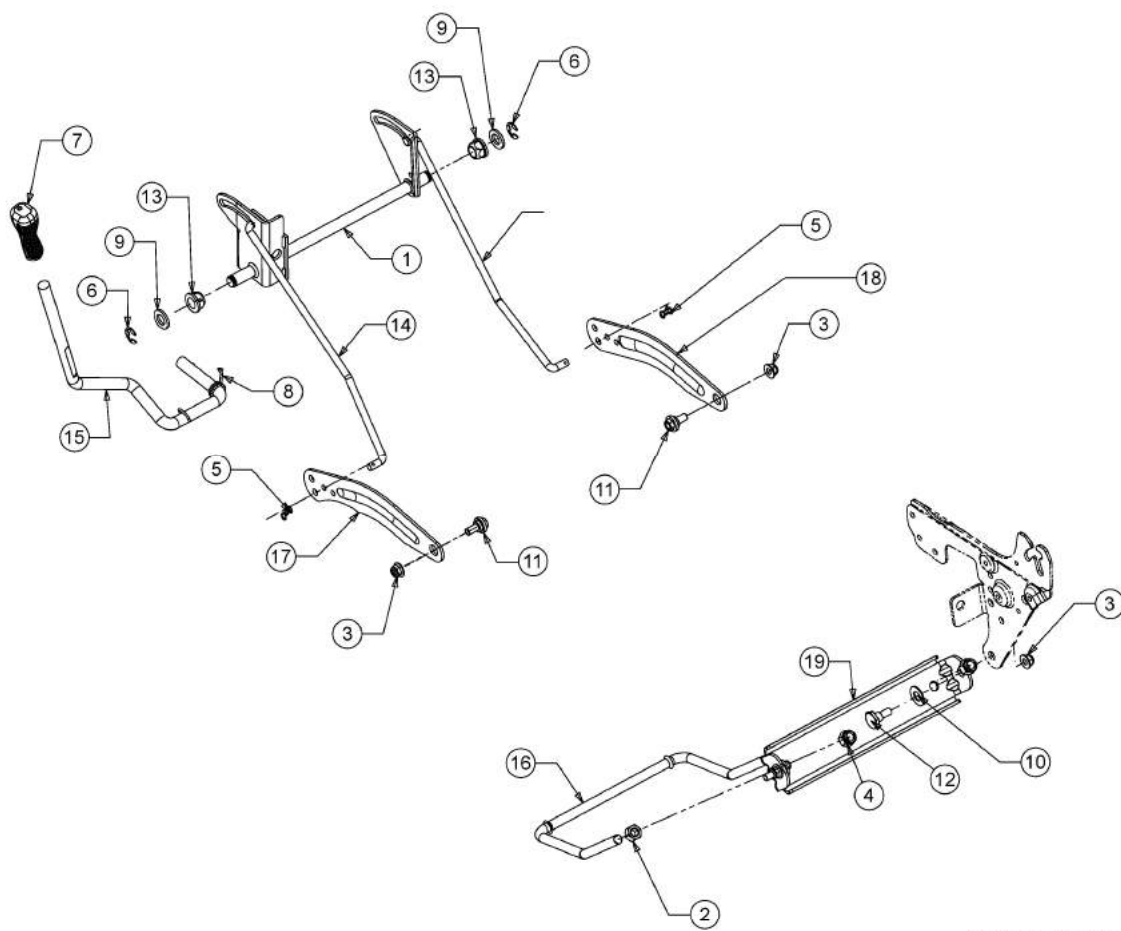

813-070188-10

Relevage plateau de coupe

Fig.	No. Pièces	D'Usignation	Numero de la norme	Nbr.
1	683-04679637	LEVIER DE RELEVAGE	SCHWEISSTEIL:FINISH LACKIERT	1
2	712-0206	ECROU HEX. 1/2-13:GR.5	FINISH:MTD SPEC-100015	2
3	712-04065	ECROU HEXAGONAL	FINISH:SPEC-100015 912-04065	4
4	712-3083	ECROU HEX. 1/2-13:GRB:NYLON	FINISH:MTD SPEC-100015	2
5	714-04040	GOUPILLE	FINISH:ASTM F1941 FE/ZN 3AN	2
6	716-0106A	CIRCLIPS	FINISH:PHOSPHATIERT	2
7	720-0298	POIGNEE	FARBE:KUNSTSTOFF SCHWARZ	1
8	732-04438	RESSORT	FINISH:701-01006	1
9	736-0366	RONDELLE 5/8 ID X 1.0 OD	FINISH:MTD SPEC-100015	2
10	736-0414	RONDELLE T_FLON	FINISH:WEISS: 936-0414	2
11	738-04130A	VIS EPAULEE	FINISH:SPEC-100016 TYPE 1	2
12	738-0507B	VIS	FINISH:MTD SPEC-701-01006	2
13	741-0225	BAGUE HEXAGONALE TEFLON 6 PANS	FINISH:KUNSTSTOFF SCHWARZ	2
14	747-05257	TRINGLE DE RELEVAGE	A/C/E/N-Deck:MTD SPEC-101616	2
15	747-05292	BRAS DE RELEVAGE	FINISH:Schwarz E-COAT	1
16	747-1324	TRINGLE	FINISH:SPEC-100015	1
17	783-04494C-S	LEVIER DE RELEVAGE DROITE	SCHWARZ	1
18	783-04711C-S	BRAS DE RELEVAGE GAUCHE	SCHWARZ	1
19	783-0720C637	SUPPORT DE RELEVAGE	SCHWARZ	1

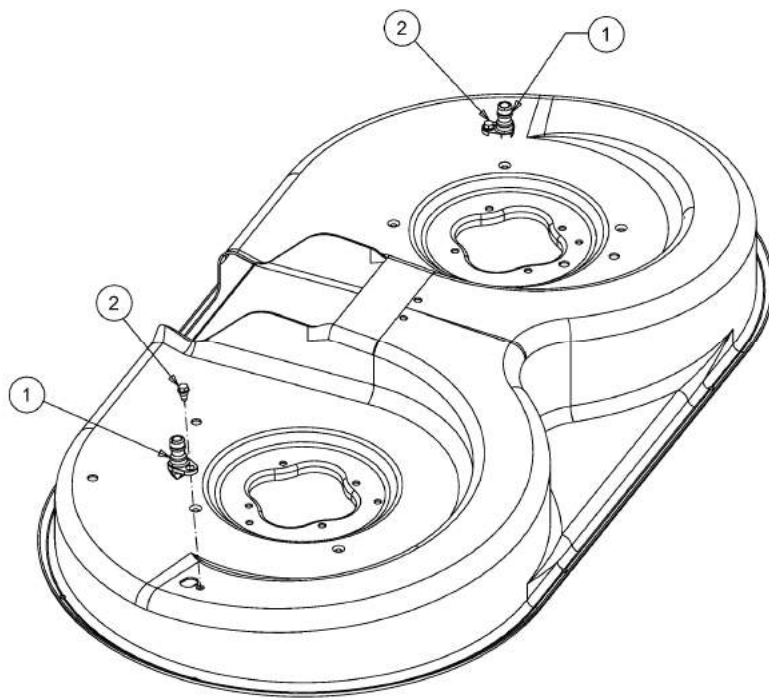

813-070181-02

TuyPre nettoyage Faucheuse

Fig.	No. PiPces	DÚsignation	Numero de la norme	Nbr.
1	731-07487	BUSE DE NETTOYAGE PLATEAU	FINISH: SCHWARZ 788-0637	2
2	738-04502	VIS	FINISH: SPEC-101625	2

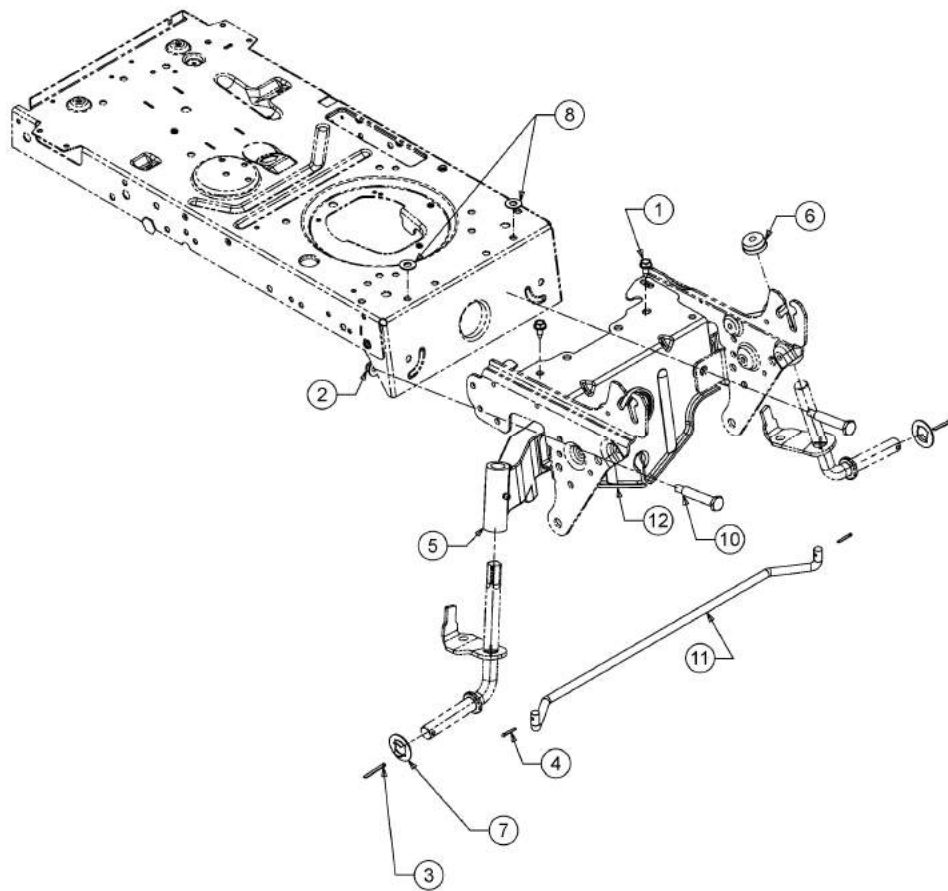

813-070806-05

Axe avant

Fig.	No. Pièces	Désignation	Numero de la norme	Nbr.
1	710-04484	VIS HEX. TT:5/16-18:.750:HXIND	FINISH:MTD SPEC-100016 TYPE 1	2
2	712-04065	ECROU HEXAGONAL	FINISH:SPEC-100015 912-04065	2
3	714-0162	GOUPILLE FENDUE 5/32:1.25	FINISH:MTD SPEC-100015	2
4	714-0474	GOUPILLE	FINISH:MTD SPEC-100015	2
5	719-04350	ESSIEU FONTE	FINISH:SCHWARZ LACKIERT	1
6	726-0341	CAPUCHON CLIPS	FINISH:SCHWARZ	1
7	736-04228B	RONDELLE	SPECIAL:FINISH SPEC-701-100015	2
8	736-05080	RONDELLE	736-05080	2
10	738-04128	VIS A EPAULE .500x2.38:3/8-16	FINISH:MTD SPEC-100015	2
11	747-04772	TRINGLE DE ROUE:LT5	FINISH:SPEC-100015	1
12	783-05326D-S	SUPPORT AVANT	783-05326D-S	1

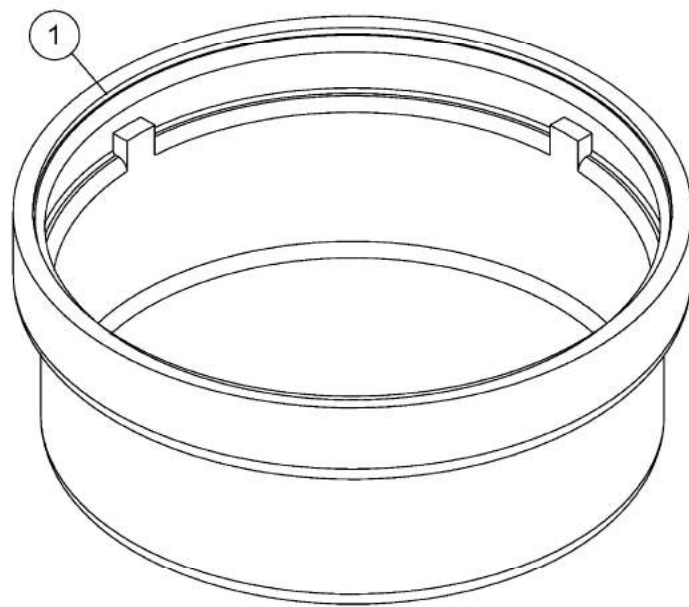

813-062012-00

Enjoliveur

Fig.	No. Pièces	Désignation	Numero de la norme	Nbr.
1	731-0484A	ENJOLIVEUR DEVANT	KUNSTSTOFF SCHWARZ 931-0484A	2

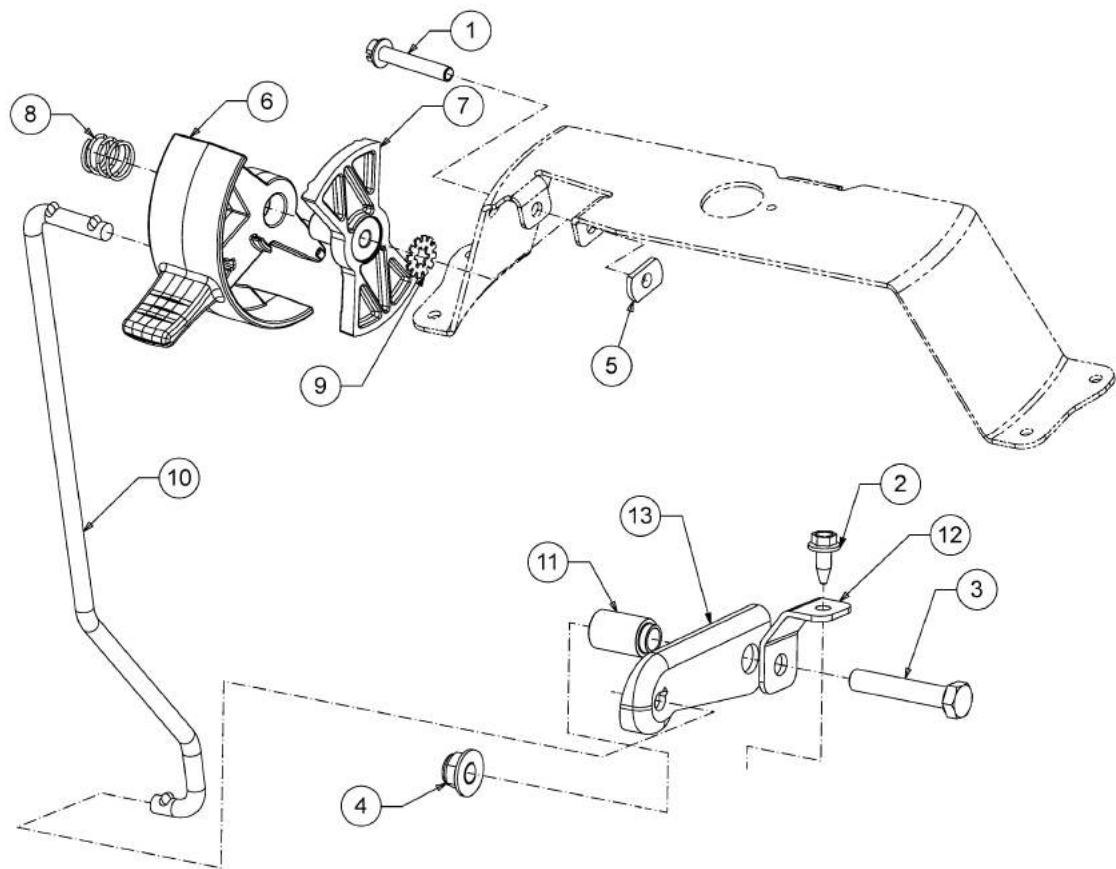

813-061064-09

Frein d'arrût

Fig.	No. Pièces	Désignation	Numero de la norme	Nbr.
1	710-04860C		710-04860C	1
2	710-1652	VIS HEX. TT:1/4-20:.625:HXINDW	FINISH:MTD-SPEC-100016 TYPE 1	1
3	710-3184A	VIS	710-3184A	1
4	712-04065	ECROU HEXAGONAL	FINISH:SPEC-100015 912-04065	1
5	712-0414	ECROU 1/4-20	FINISH:PLAIN	1
6	731-07885B	POIGNEE DE VITESSE	FINISH:KUNSTSTOFF GELB	1
7	731-07966A	SELECTEUR	FINISH PLAIN: (SCHWARZ)	1
8	732-04877	RESSORT	FINISH:MTD SPEC-100015	1
9	736-3006	RONDELLE 1/4 X -75	FINISH:SPEC-100016	1
10	747-05398	TRINGLE DE VITESSE	FINISH:SPEC-100015	1
11	750-04465C	ENTRETOISE	FINISH:GEILT	1
12	783-06823	SUPPORT	KONTROLLHEBEL:VERZ.SIEHE ZG.	1
13	783-06991	SUPPORT	SD-TR./HYDRO:783-06991-Z	1

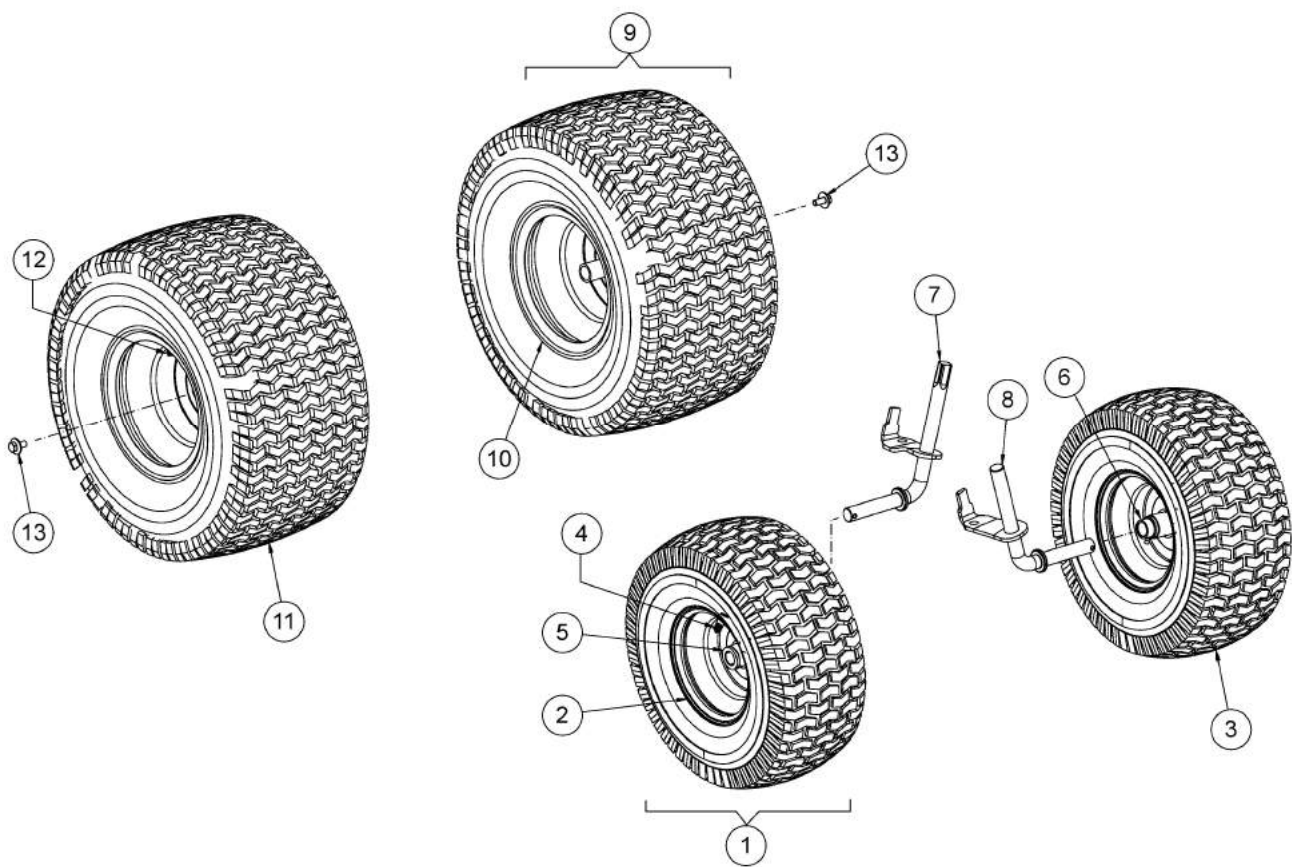

813-070159-05OG

Roues, fusées d'essieu

Fig.	No. Pièces	Désignation	Numero de la norme	Nbr.
1	634-04406-G	ROUE COMPLETE 15X6.0X6 GRISE	FELGE:OYSTER GRAY 788-0662	2
2	634-04405662	JANTE AVANT GRISE	FINISH:OYSTER GRAY 788-0662	2
3	734-1731	PNEU 15X600X6 DICO MULTI-TRAC	SQ SHOULDER:TURF SAVER	2
4	734-0255	VALVE:PNEU	TR 412-P / 32.6mm / 934-0255	2
5	741-0990B	BAGUE DE ROUE AVEC GRAISSEUR	m.SCHMIERNIPPEL:FINISH SCHWARZ	2
6	741-0516B	BAGUE DE ROUE .760x1.00x1.20	FINISH:SCHWARZ	2
7	638-04013637	FUSEE DROITE	SCHWEISSTEIL:LACKIERT	1
8	638-04014A-S	FUSEE GAUCHE	SCHWARZ	1
9	734-04523AOG	ROUE COMPLETE 18X9.50 GRISE	FELGE:OYSTER GRAY 788-0662	2
10	634-04631662	JANTE AR GRISE	FINISH:OYSTER GRAY 788-0662	2
11	734-1729	PNEU 18 X 9,50 - 8	CHARLISLE	2
12	734-0255	VALVE:PNEU	TR 412-P / 32.6mm / 934-0255	2
13	710-05339A	VIS	FINISH:MTD STD SPEC-101617	2

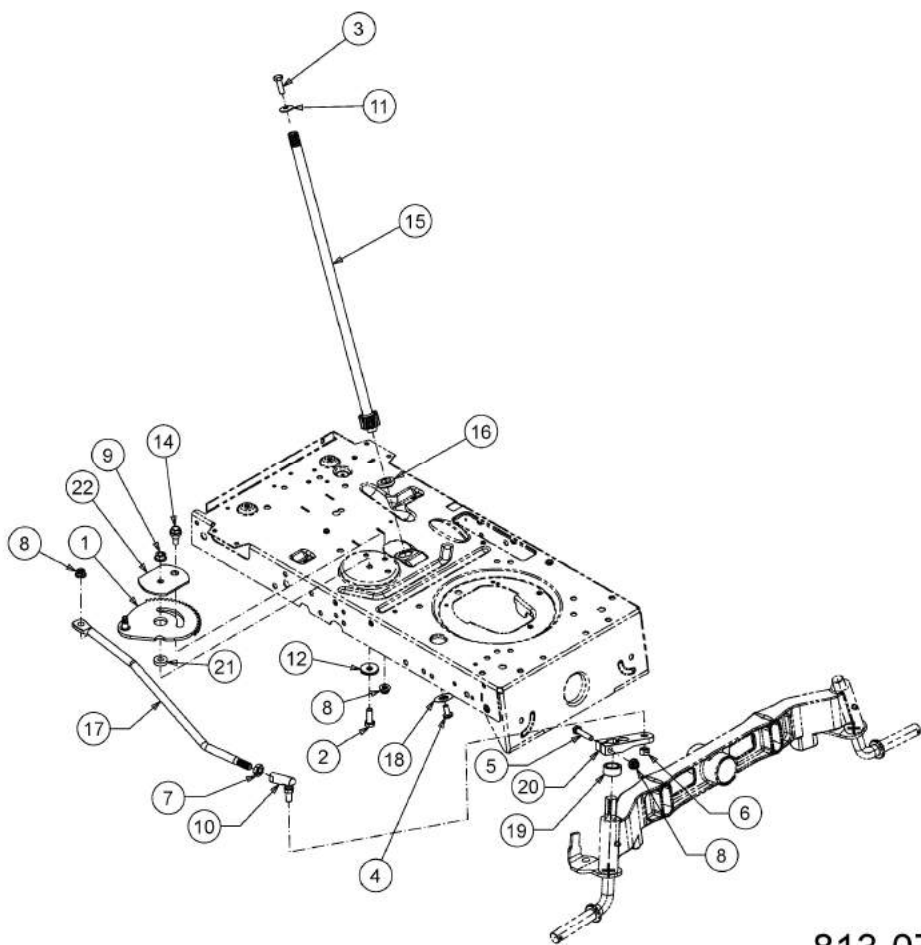

813-070017-19

Système direction

Fig.	No. Pièces	Désignation	Numero de la norme	Nbr.
1	617-04094	SEGMENT DE DIRECTION	SCHWEISSTEIL:PHOS & OIL	1
2	710-0514	VIS HEX.:3/8-16:1.00:GR5:STD	FINISH:MTD SPEC-100015	1
3	710-0643	VIS HEX.: 5/16-18:1.00:GR5	FINISH:MTD SPEC-100015	1
4	710-1309	VIS	FINISH:MTD SPEC-100015	1
5	710-3180	VIS HEX. 5/16-18:1.75:GR5:STD	FINISH:SPEC-100015	1
6	712-0214	ECROU	FINISH:SPEC-100015	1
7	712-0240	ECROU HEX.: 7/16-20:GR2	FINISH:MTD SPEC-100015	1
8	712-04063	ECROU HEX. AVEC FLANC	FINISH:MTD SPEC-100015	3
9	712-0431	ECROU STOP 3/8-16:GRF	FINISH:MTD SPEC-100015	1
10	723-0448A	ROTULE DE DIRECTION 7/16-20	FINISH:MTD SPEC-100015	1
11	736-0242	RONDELLE CONIQUE.340X.872X.060	FINISH:MTD SPEC-100016	1
12	736-0331	RONDELLE CONIQUE	FINISH:MTD SPEC-100016	1
14	738-04141	AXE	FINISH:SPEC-100015	1
15	738-07154		738-07154	1
16	741-04124	PALIER DE BRIDE	FINISH:PLAIN	1
17	747-05464	TRINGLE DE DIRECTION	FINISH:MTD SPEC-100015	1
18	748-0389	BAGUE	FINISH:GEILT	1
19	748-04068	DOUILLE .71IDX.125 ODX.56 LG	FINISH:SPEC-100015	1
20	748-04278-Z	BIELETTE DE DIRECTION	FINISH:MTD-SPEC-100015	1
20	748-04278ZW	BIELETTE DE DIRECTION	FINISH:BLAU CHROMATIEREN	1
21	750-06192A	ENTRETOISE	FINISH:DAMPFBEHANDELT	1
22	783-08577A	PLAQUE DE SEGMENT	FINISH:PHOS&OIL or SPEC-100015	1

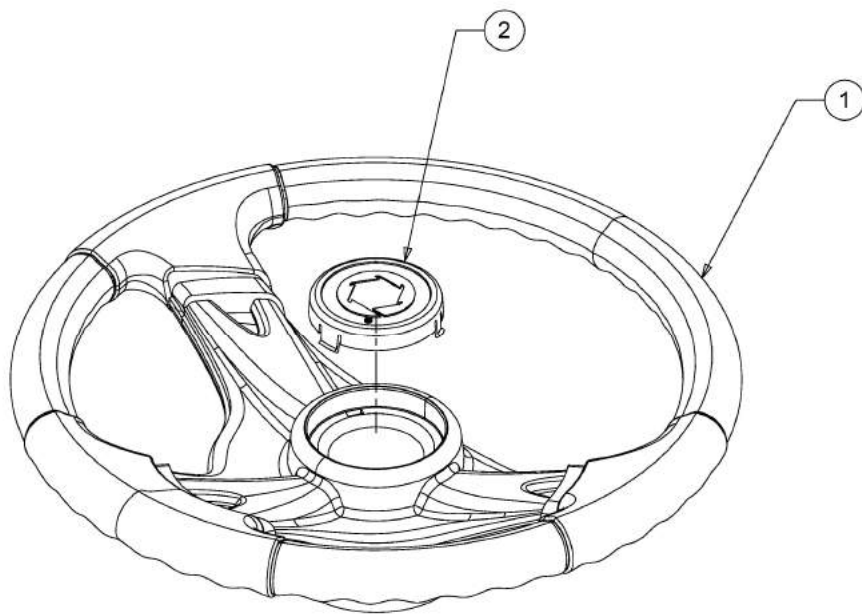

813-010305-00

Volant

Fig.	No. Pièces	Désignation	Numero de la norme	Nbr.
1	631-04028	VOLANT	FINISH SCHWARZ	1
2	731-04681		FINISH: SCHWARZ NON CE	1

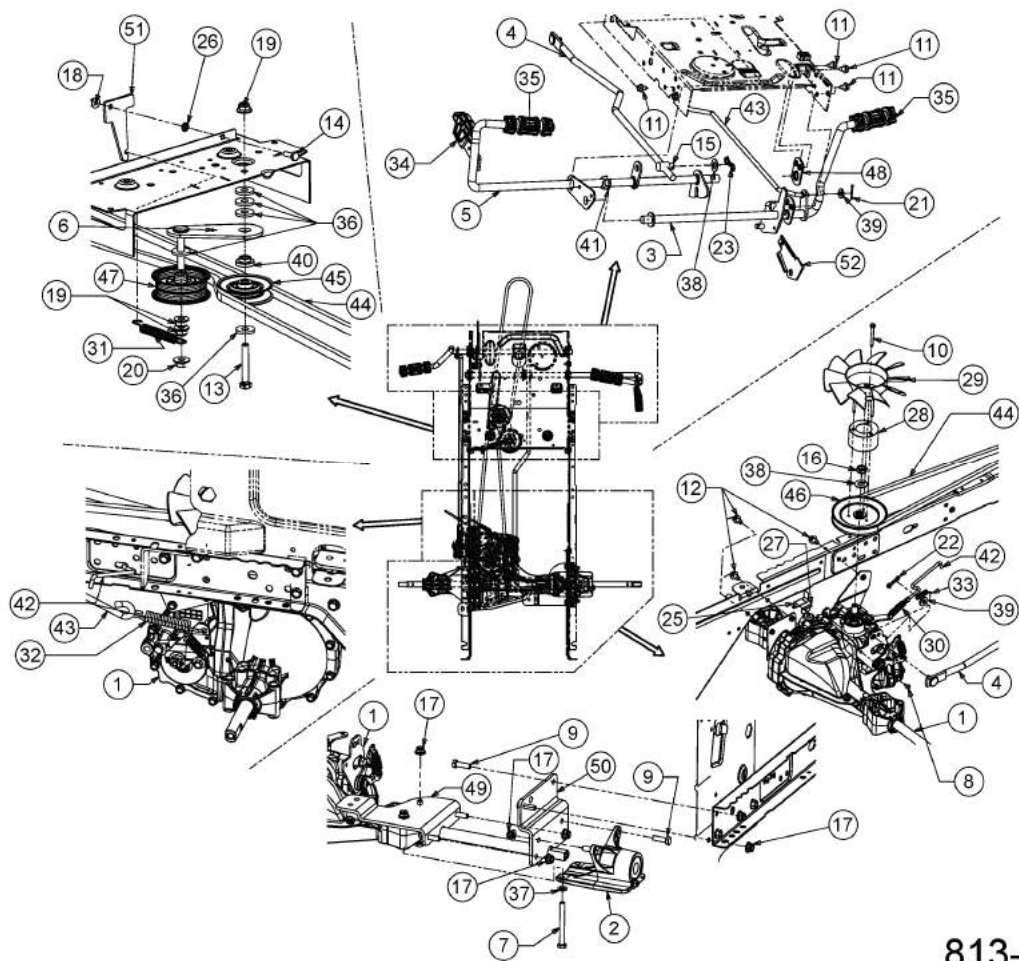

813-070152-38

Boîte de vitesse hydrostatique, Courroie, Pedales Ó partir

Fig.	No. Pièces	Désignation	Numero de la norme	Nbr.
1	618-04911	PONT HYDRO HG T2	FINISH: N/A	1
2	619-06358			1
3	647-04215A	LEVIER DE FREIN	SCHWEISSTEIL:LACKIERT	1
4	647-05061-Z	ARBRE DE PEDALE	FINISH:MTD SPEC 100015	1
5	647-05393B-Z			1
6	683-0604A	CADRE SUPP. CPL.:GAL. TEND. DB	SCHWEISSTEIL:683-0604A-Z	1
7	710-0189	VIS HEX.:5/16-18x3.00:GR5:STD	FINISH:SPEC-100015 910-0189	2
8	710-0227	VIS	FINISH:MTD SPEC-100016 TYPE 1	1
9	710-0376	VIS HEX.:5/16-18:1.00:GR5:STD	FINISH:MTD SPEC 701-01006	6
10	710-05067	VIS	FINISH:MTD SPEC-100016 TYPE 1	3
11	710-0604A	VIS 5/16-18:0.625	FINISH:MTD SPEC-100016 TYPE 1	5
12	710-0607	VIS HEX.TT5/16-18:.500HXINDWSh	FINISH:MTD SPEC-100016 TYPE 1	4
13	710-3011	VIS HEX.:3/8-16:2.25:GR5:STD	FINISH:MTD SPEC-100015	1
14	710-3015	VIS:1/4-20:.75:GR5:STD	FINISH:MTD SPEC-100015	1
15	711-04036	AXE	FINISH:SPEC-100015 911-04036	1
16	712-0346	ECROU HEX. 1/2-20:GR5:NYLON	FINISH:SPEC-100015 912-0346	1
17	712-04063	ECROU HEX. AVEC FLANC	FINISH:MTD SPEC-100015	8
18	712-04064	ECROU HEXAGONAL	FINISH:SPEC-100015 912-04064	1
19	712-04065	ECROU HEXAGONAL	FINISH:SPEC-100015 912-04065	3
20	712-04217	ECROU	FINISH:MTD SPEC-100015	1
21	714-0111	GOUPILLE FENDUE 3/32:1.0"	FINISH:MTD SPEC-100015	1
22	714-04040	GOUPILLE	FINISH:ASTM F1941 FE/ZN 3AN	1
23	714-05005	GOUPILLE	FINISH:ASTM F1941 FE/ZN 3AN	1
25	725-05050	SUPPORT DE SECURITE	FINISH:SPEC-100015	1
26	726-0233	RONDELLE	MECHANISCH KLAR VERZINKT	1
27	726-04089	PLAQUE ISOLANTE	FINISH:NATUR ODER SCHWARZ	1
28	731-07514	ENTRETOISE PLASTIQUE	FINISH:KUNSTSTOFF SCHWARZ (Dí)	1
29	731-1449A	HELICE DE REFROIDISSEMENT	FINISH:WEISS	1
30	732-0209	RESSORT DE TRACT.	FINISH:MTD 701-01006 932-0209	1
31	732-0429A	RESSORT	FINISH:PHOSPHATE AND OIL	1
32	732-0716D	RESSORT	FINISH:MTD STD 701-01006	1
33	732-3118	RESSORT	FINISH:SPEC-100015	1
34	735-05028	CAOUTCHOUC DE PEDALE	FINISH:SCHWARZ SIEHE ZG.	1
35	735-05051	CAOUTCHOUC DE PEDALE DE FREIN	FINISH:SCHWARZ SIEHE ZG.	2
36	736-0258	RONDELLE PLATE .385x1.0x.135	FINISH:SPEC-100015 936-0258	5
37	736-0264	RONDELLE: .330 x.630 x.0635	FINISH:SPEC-100015 936-0264	2
38	736-0272	RONDELLE .510x1.00X.060	SPEC 100015 oder SPEC-101616	2
39	736-3008	RONDELLE	FINISH:MTD SPEC-100015	2
40	738-0372B	RONDELLE EPAULEE	FINISH:GEÍLT	1
41	741-3065B	BAGUE HEXAGONALE RAINUREE	GESCHLITZT:FINISH SCHWARZ	1
42	747-05298	TRINGLE	FINISH:SPEC-100015	1
43	747-05313	TRINGLE DE FREIN	FINISH:SPEC-100015 or ECOAT	1
44	754-04258	COURROIE DE TRANSMISSION	POLY	1
45	756-05234	POULIE	FINISH:SCHWARZ LACKIERT	1
46	756-1052	POULIE PLATE BOITE DE V	FINISH:SPEC-100015	1
47	756-3054A	POULIE TENDEUR	FINISH:VERZINKT SPEC-100015	1
48	783-04536B-S	SUPPORT	SCHWARZ LACKIERT	1
49	783-06563637	SUPPORT	SCHWARZ	1
50	783-06577637	SUPPORT	FINISH:MTD SCHWARZ	1
51	783-06582A-S	PATTE		1
52	783-08349A		VERZINKEN UND VERSIEGELN *	1

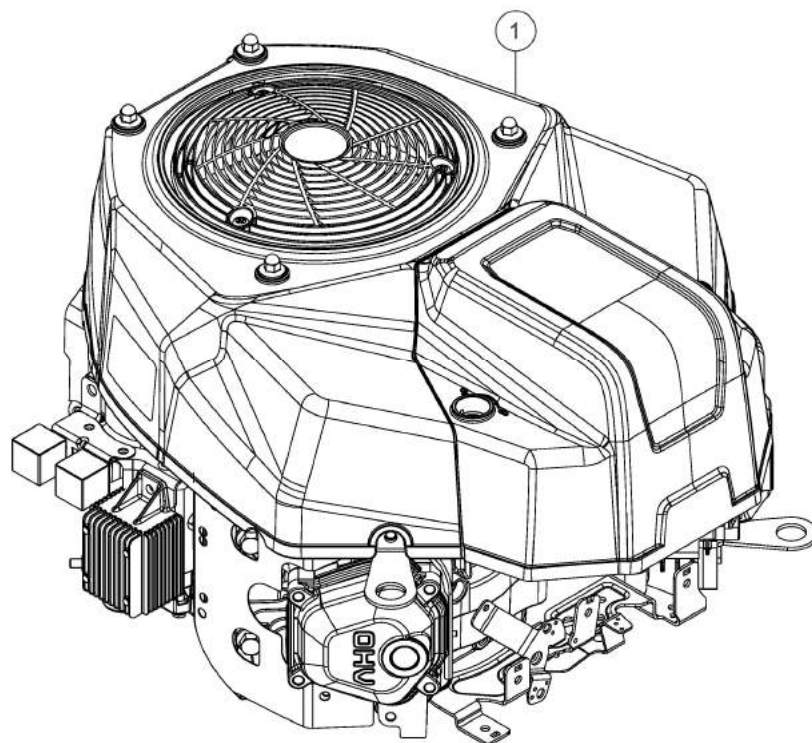

Modell: 4Q78HW

E3-11412A-01

Moteur

Fig.	No. Pièces	Désignation	Numero de la norme		Nbr.
1	752Z4Q78HW		MODELL:4Q78HW	STAGE V	1

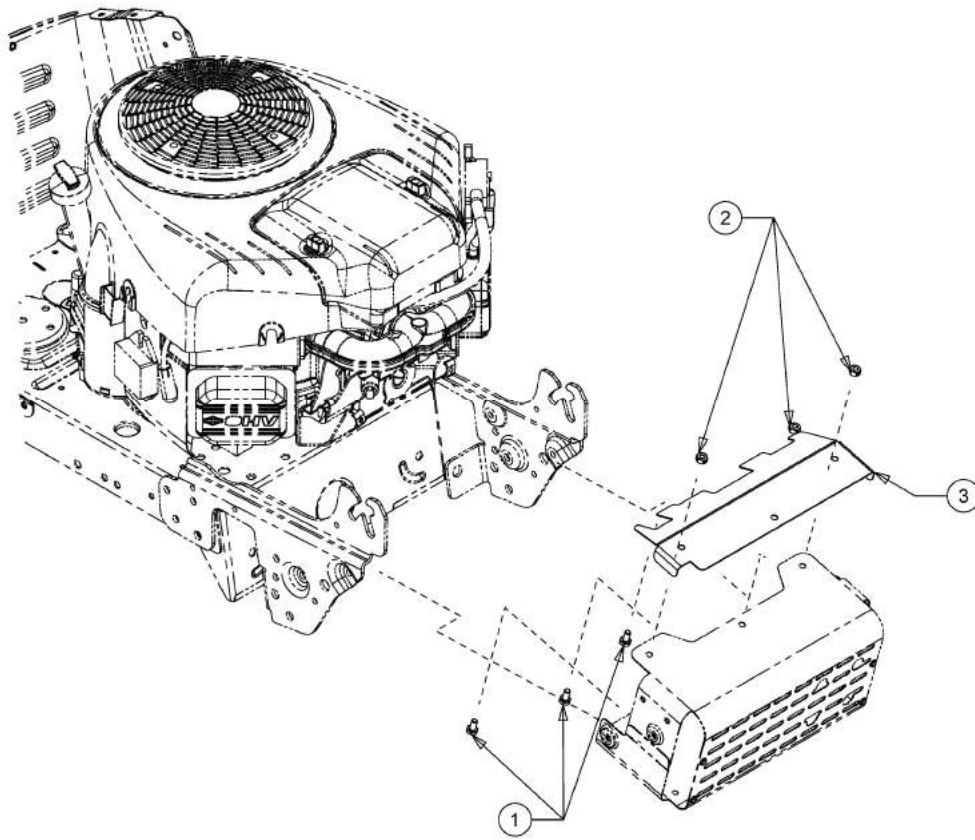

813-062278-03

Protection thermique

Fig.	No. Pièces	Désignation	Numero de la norme	Nbr.
1	710-3013	VIS HEXAGONALE	FINISH:MTD SPEC-100015	3
2	712-3027	ECROU HEXAGONAL 1/4-20:GRF	FINISH:MTD SPEC-100015	3
3	783-09038A		SCHALLD-MPFER:FINISH:PLAIN	1

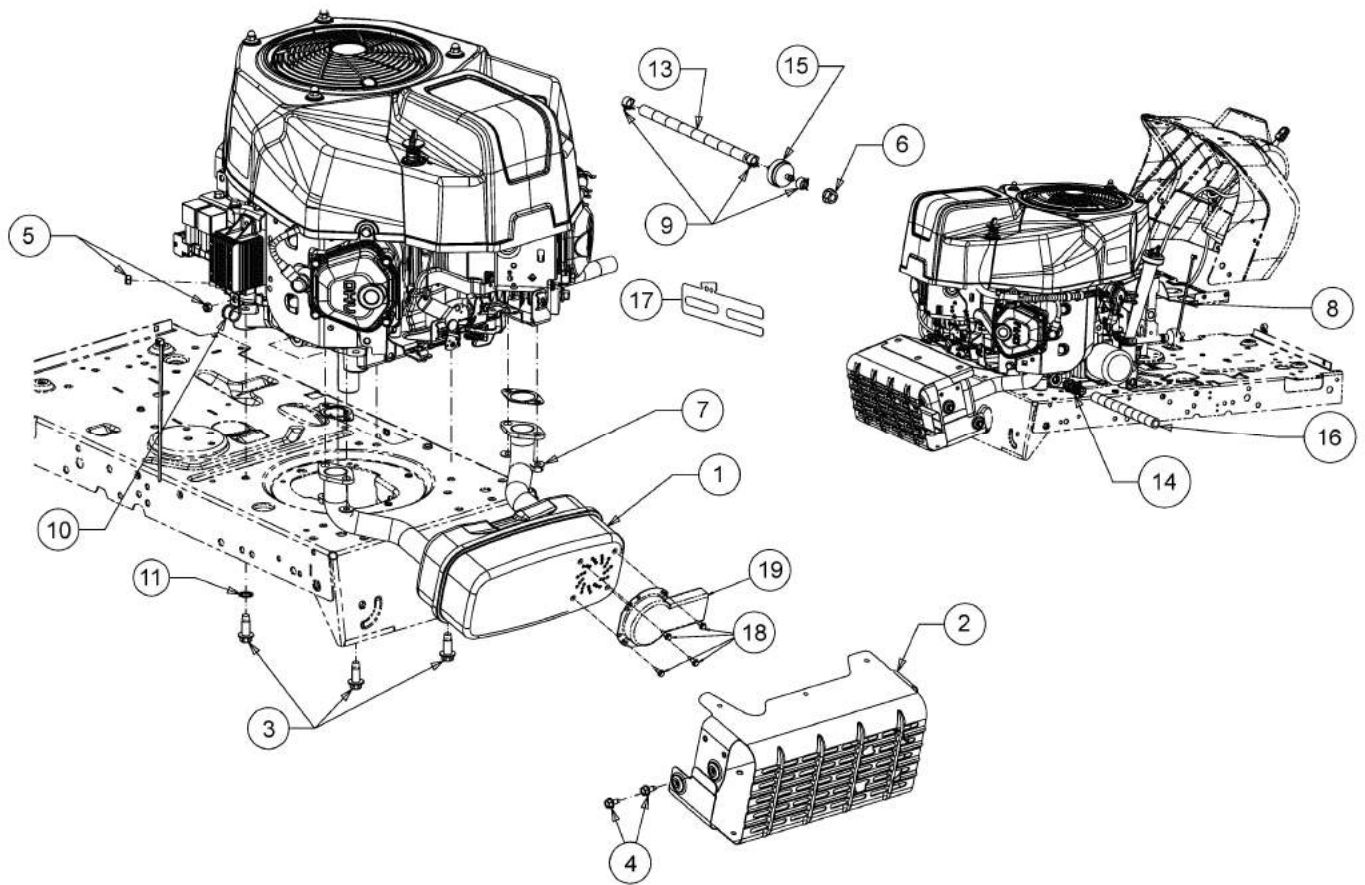

813-062348-10

Accessoires moteur

Fig.	No. Pièces	DÚsignation	Numero de la norme	Nbr.
1	751-15807C		751-15807C	1
2	683-05460A			1
3	710-04683C	VIS	FINISH:SIEHE ZG.	4
4	710-0599	VIS A SIX PANS CREUX	FINISH:MTD SPEC-101617	4
5	712-0691	ECROU HEXAGONAL	MTD SPEC-100015 24.1426.14	2
6	712-04242	ECROU	FINISH:MTD SPEC-100015	1
7	712-3086	ECROU/FLANC: M8-1.25	FINISH:MTD SPEC-100015	4
8	725-0157	COLLIER DE SERRAGE3/16X0.5X7.4	MATERIAL:NYLON-SCHWARZ	2
9	726-0205	COLLIER DE SERRAGE DE BOYAU	FINISH:PHOS UND GELB LACKIERT	3
10	726-0272	COLLIER	FINISH:MTD SPEC-100015	1
11	736-0148	RONDELLE	FINISH:MTD SPEC-100016	1
13	751-10349A			8
14	751-10517A	DRAINAGE D¿HUILE	FINISH:SIEHE ZG.	1
15	751-3013	FILTRE ESSENCE	COLOR:RED 951-3013	1
16	751-3141	TUYAU VIDANGE	13 X 3:FINISH KLAR METERWARE	9
17	783-06232-Z	SUPPORT	FINISH:VERZINKT	1
18	710-06625	VIS 8-32X0.47:HXWSH	FINISH:ASTM F1137 GRADE D	4
19	751-11053B		LANGER ABGASKANAL:ALUMINIZED	1

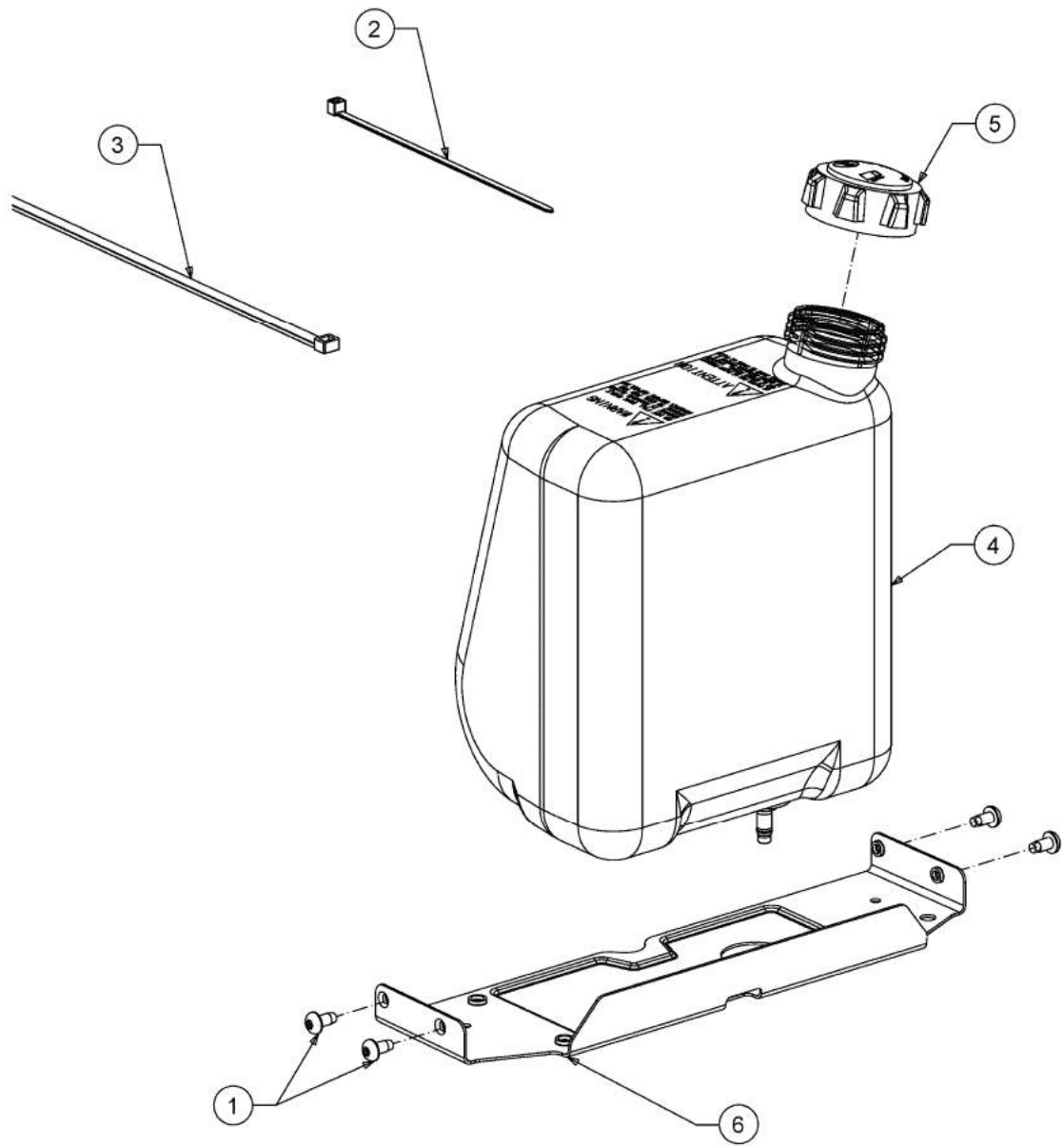

813-061066-06

RÚservoir

Fig.	No. Pièces	DÚsignation	Numero de la norme	Nbr.
1	710-05070A	VIS	FINISH: SCHWARZ SPEC-000087	4
2	725-0157	COLLIER DE SERRAGE 3/16X0.5X7.4	MATERIAL: NYLON-SCHWARZ	1
3	726-0230	COLLIER	FINISH: SCHWARZ	1
4	751-0555B	RESERVOIR D'ESSENCE: 5.7L	FINISH: NATUR	1
5	751-0603B	BOUCHON ESSENCE	FINISH: KUNSTSTOFF SCHWARZ	1
6	783-07083A-S	SUPPORT DE RESERVOIR ESSENCE	FINISH: LACKIERT MTD QUALIT-T	1

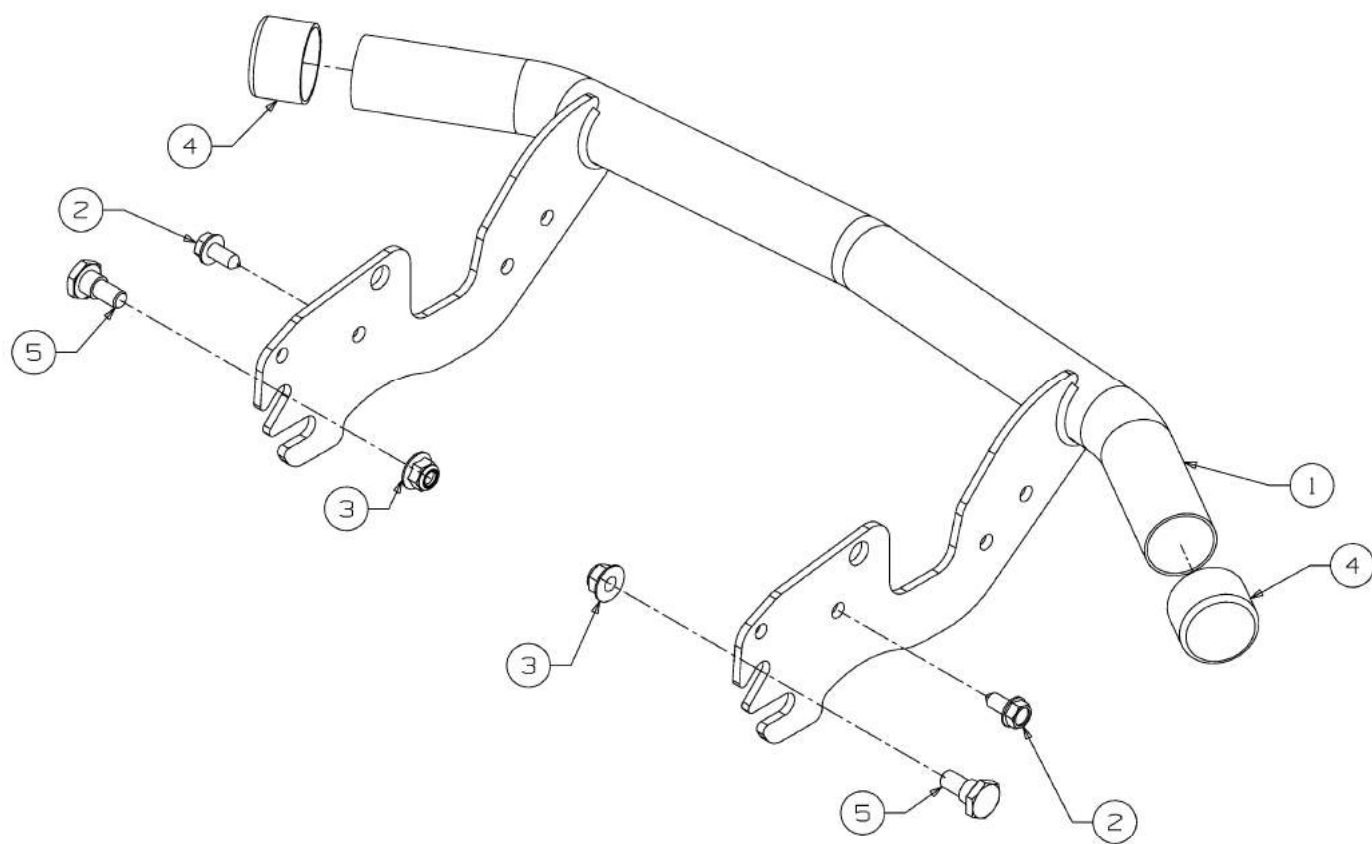

E3-04542B-01

Pare-chocs

Fig.	No. Pièces	Désignation	Numero de la norme	Nbr.
1	683-04219B	PARE-CHOC	683-04219B-0637	1
2	710-04484	VIS HEX. TT:5/16-18:.750:HXIND	FINISH:MTD SPEC-100016 TYPE 1	2
3	712-3000	ECROU 3/8-16 GR.B CTRLK	FINISH:MTD STD 701-01000	2
4	731-05674	BOUCHON	731-05674	2
5	738-0143	VIS EPAULEE	FINISH:MTD SPEC 100015 (EU)	2

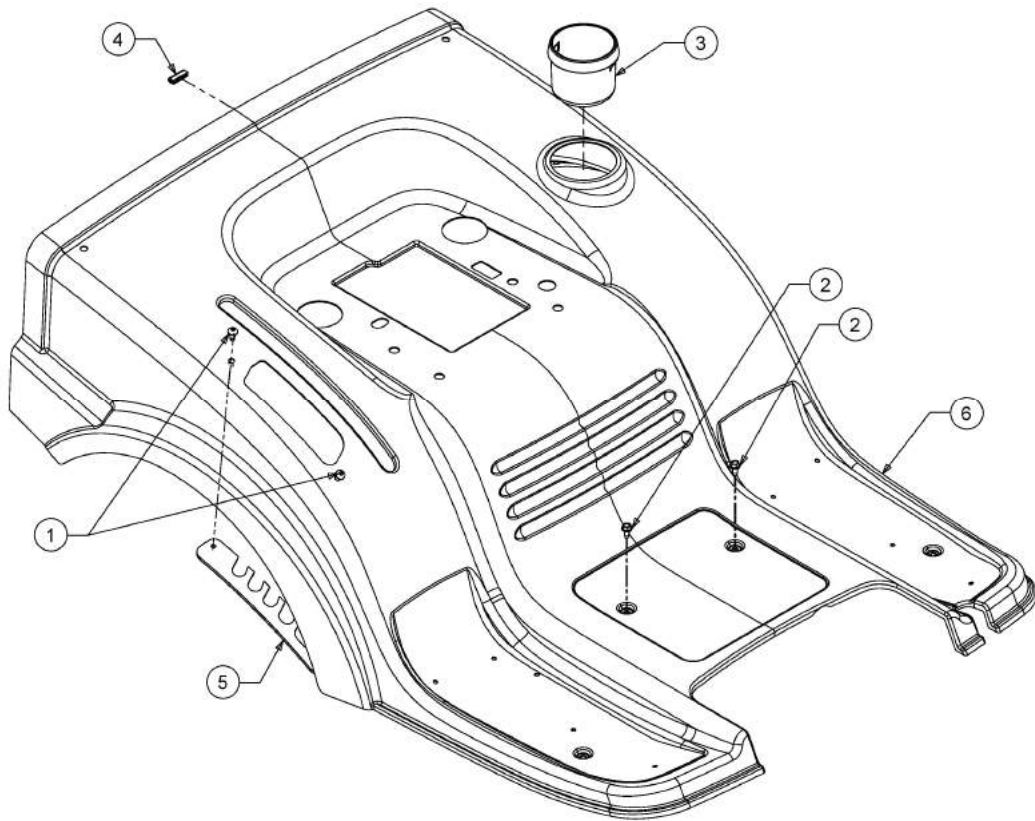

813-070179-08R

Jupe

Fig.	No. Pièces	Désignation	Numero de la norme	Nbr.
1	710-05070A	VIS	FINISH: SCHWARZ SPEC-000087	2
2	710-0599	VIS A SIX PANS CREUX	FINISH: MTD SPEC-101617	2
3	731-04591A	PORTE GOBELET	FINISH: KUNSTSTOFF SCHWARZ	1
4	731-0511	BORDURE DE PROTECTION	FINISH: SCHWARZ, SIEHE ZG.	1
5	783-05875A	SELECTEUR HAUTEUR DE COUPE	FINISH: 783-05875A-Z 5 POS	1
6	783-06580638	JUPE ROUGE MTD	MTD ROT	1

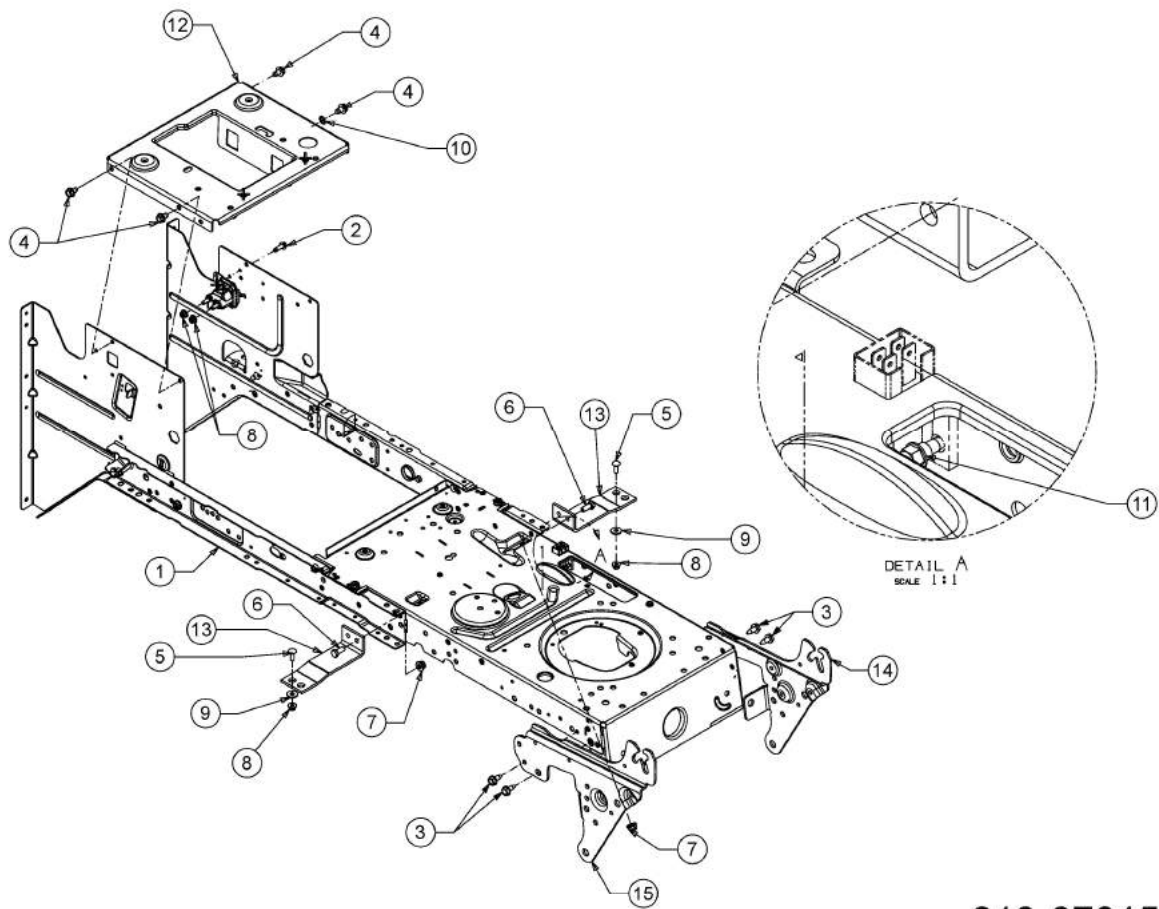

813-070155-19

ChÔssis

Fig.	No. Pièces	DÚsignation	Numero de la norme	Nbr.
1	683-04681G-S			1
2	710-04461	VIS	FINISH:SIEHE ZG.	1
3	710-04484	VIS HEX. TT:5/16-18.:750:HXIND	FINISH:MTD SPEC-100016 TYPE 1	4
4	710-0607	VIS HEX.TT5/16-18.:500HXINDWSh	FINISH:MTD SPEC-100016 TYPE 1	4
5	710-0703	VIS	FINISH:MTD SPEC-100015	2
6	710-3008	VIS 5/16-18.:75:GR5:STD	SPEC-701-01006 or.SPEC-100015	2
7	712-04063	ECROU HEX. AVEC FLANC	FINISH:MTD SPEC-100015	3
8	712-04064	ECROU HEXAGONAL	FINISH:SPEC-100015 912-04064	4
9	736-0173	RONDELLE 281DX 74ODX.063	FINISH:MTD SPEC-100015	2
10	736-0607	RONDELLE	FINISH:MTD SPEC-100016	1
11	738-04237A	AXE EPAULE	FINISH:MTD SPEC-100016	1
12	783-04548D-R	SUPPORT DE SIEGE	MTD ROT	1
13	783-04637637	SUPPORT	SCHWARZ LACKIERT	2
14	783-05417B-S	+TRIER DE CHARN.:+ GA. CAPOT	783-05417B-S	1
15	783-05418D-S	+TRIER DE CHARN.:+ DR. CAPOT	783-05418D-S	1

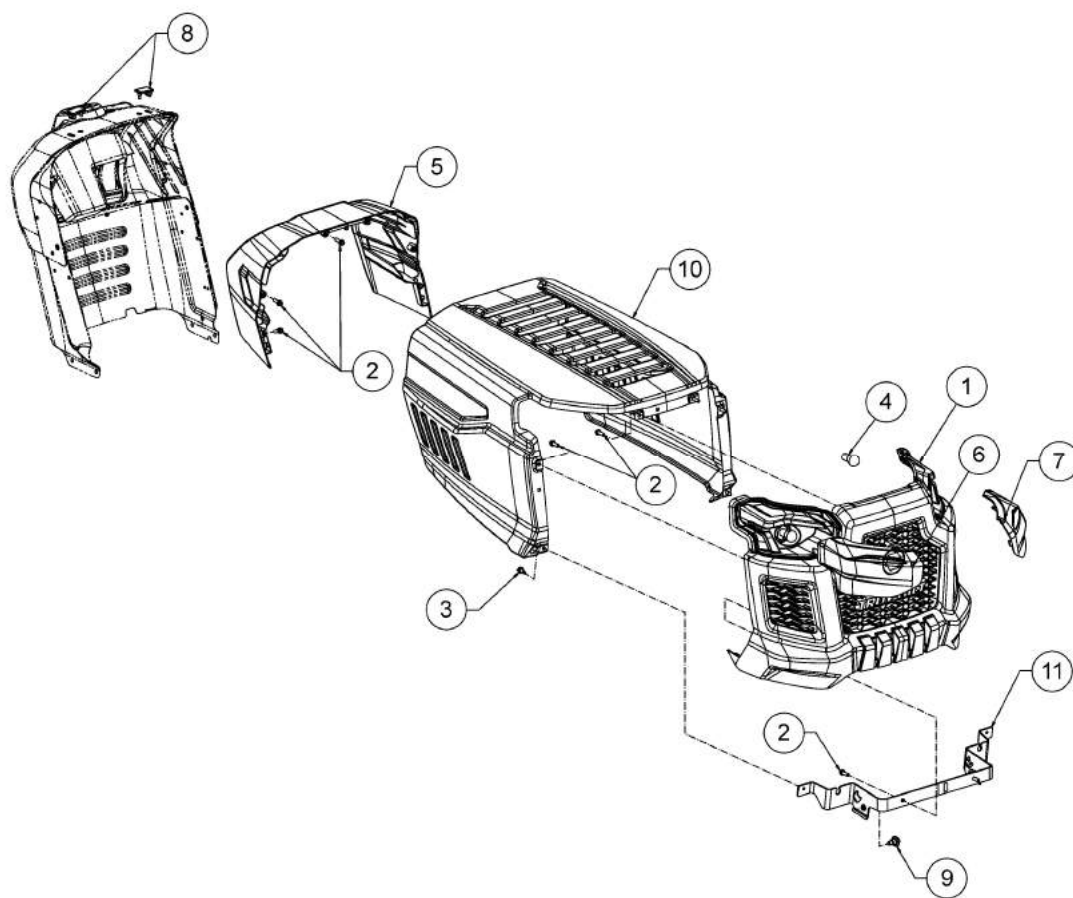

813-062321-06

Capot de moteur

Fig.	No. Pièces	Désignation	Numero de la norme	Nbr.
1	631-05502			1
2	710-05108	VIS	FINISH:SPEC-701-01006	12
3	710-1652	VIS HEX. TT:1/4-20:.625:HXINDW	FINISH:MTD-SPEC-100016 TYPE 1	2
4	725-0963	AMPOULE ELECTRIQUE	FINISH:	2
5	731-12615			1
6	731-12657A			1
7	731-12661A			1
8	735-05199			2
9	738-04091A	VIS EPAULEE	FINISH:SPEC-100016	2
10	783-09469			1
11	783-09471			1

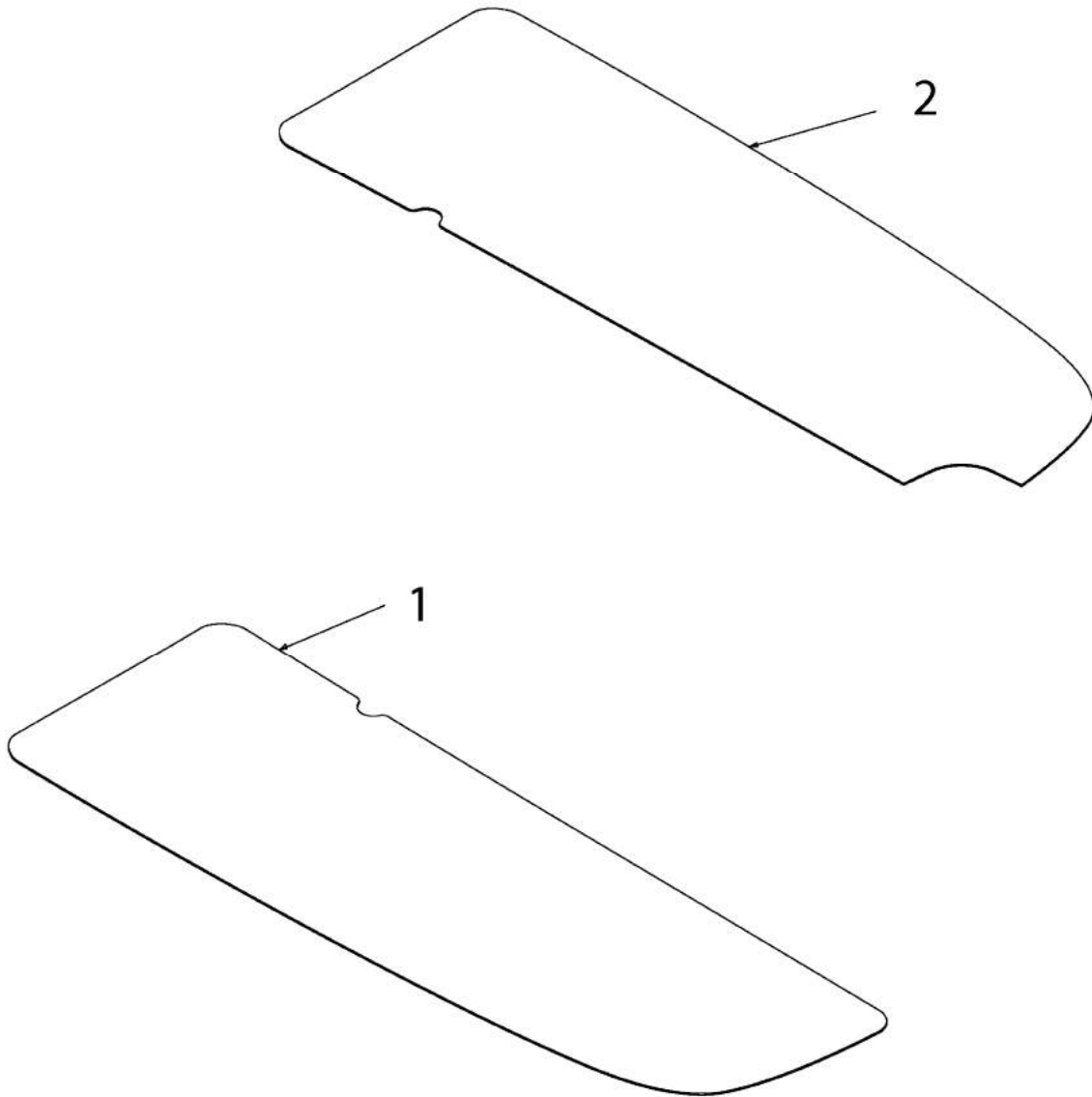

E3-02721A-01

Marchepied garniture

Fig.	No. Pièces	Désignation	Numero de la norme	Nbr.
1	723-04025	MARCHE PIED DROITE	FARBE: SCHWARZ	1
2	723-04026	MARCHE PIED GAUCHE	FARBE: SCHWARZ	1

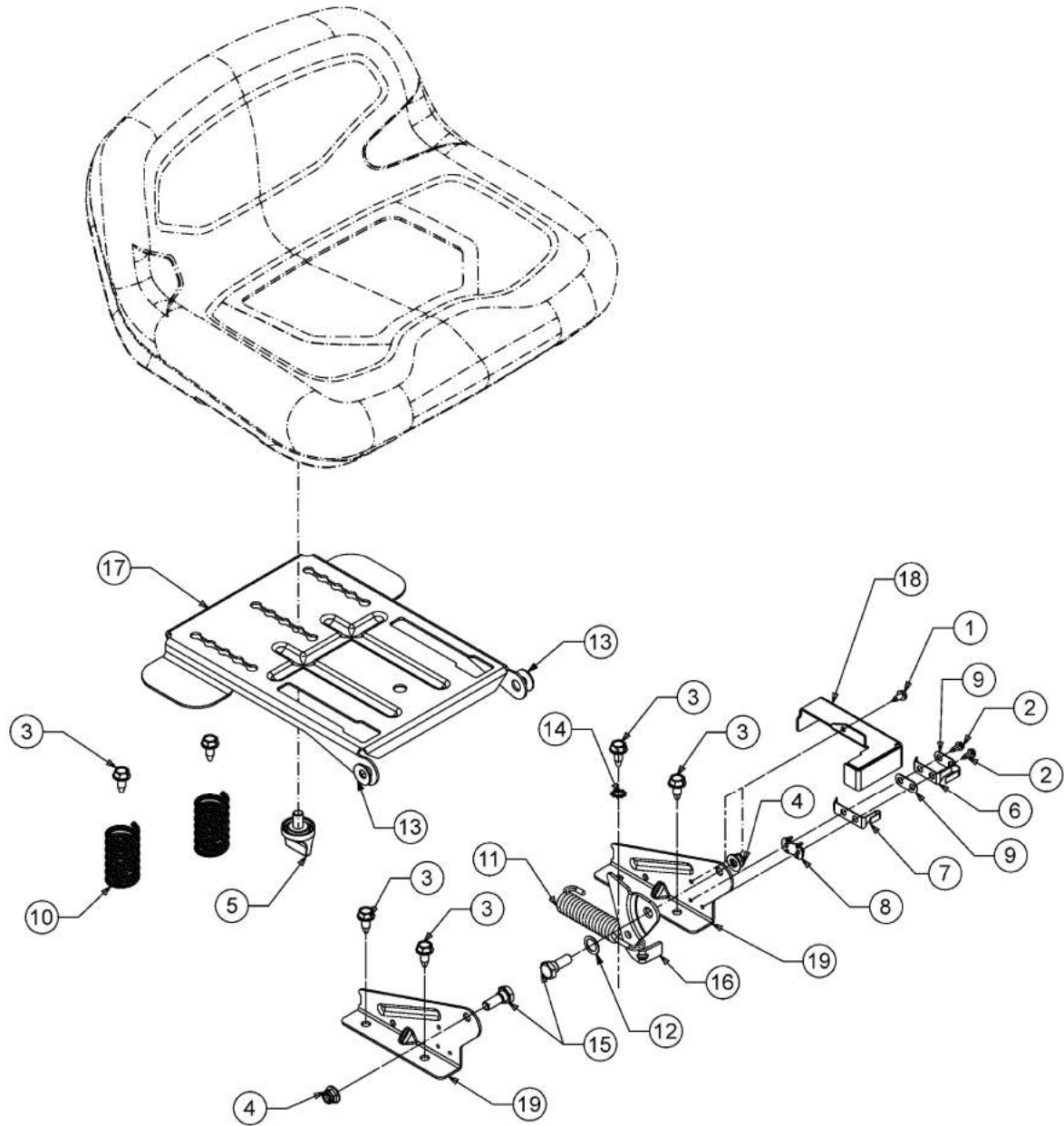

813-070788-05

RÚglage de siége

Fig.	No. Pièces	Désignation	Numero de la norme	Nbr.
1	710-0224	VIS PARK:#10-16:0.500:HXINDWSH	FINISH:MTD SPEC-100016 TYPE 1	1
2	710-0227	VIS	FINISH:MTD SPEC-100016 TYPE 1	2
3	710-04484	VIS HEX. TT:5/16-18.:750:HXIND	FINISH:MTD SPEC-100016 TYPE 1	6
4	712-04063	ECROU HEX. AVEC FLANC	FINISH:MTD SPEC-100015	2
5	720-05164		FINISH:SCHWARZ	1
6	725-1303	RESSORT DE SURETE SIÉGE	SI.-SCHALTER SITZ:SPEC-100015	1
7	725-1439	RESSORT SURETE DE SIEGE	SI.-SCHALTER SITZ:SPEC-100015	1
8	726-0278	PLAQUE D'ISOLATION	FINISH:NATUR ODER SCHWARZ	1
9	726-0279	PLAQUE D'ISOLATION	FINISH:NATUR ODER SCHWARZ	2
10	732-0735A	RESSORT DE SIEGE	FINISH:MTD SPEC 101616	2
11	732-08282	RESSORT	732-08282	1
12	736-0108	RONDELLE	FINISH:MTD SPEC-100015	1
13	736-0242	RONDELLE CONIQUE.340X.872X.060	FINISH:MTD SPEC-100016	2
14	736-0607	RONDELLE	FINISH:MTD SPEC-100016	1
15	738-0296	AXE EPAULE	FINISH:SPEC-100015	2
16	783-0209D	SUPP. SIÉGE	FINISH:SPEC-100016	1
17	783-04081D-S	PLAQUE DE SIEGE NOIRE	SCHWARZ	1
18	783-04877A-S	PROTECTION DE SECURITES DE	SCHWARZ / 788-0637	1
19	783-1489D637	SUPPORT DE SIEGE NOIR	SCHWARZ	2

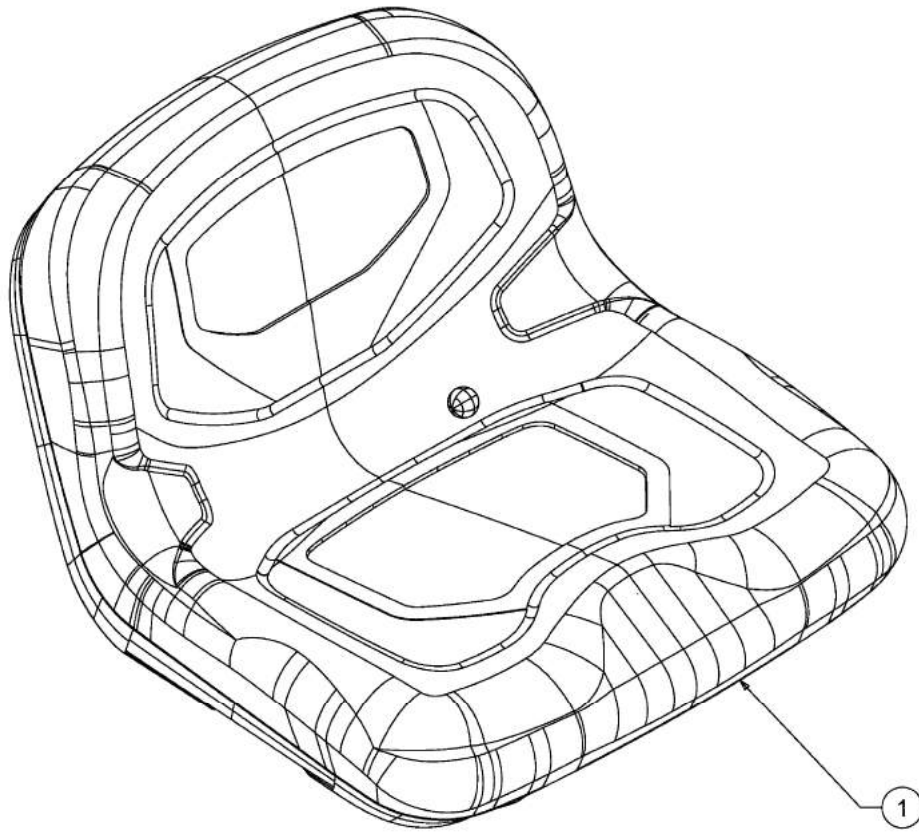

813-062983-00

Siège

Fig.	No. Pièces	Désignation	Numero de la norme	Nbr.
1	757-05229	SIEGE	FARBE: SCHWARZ	1

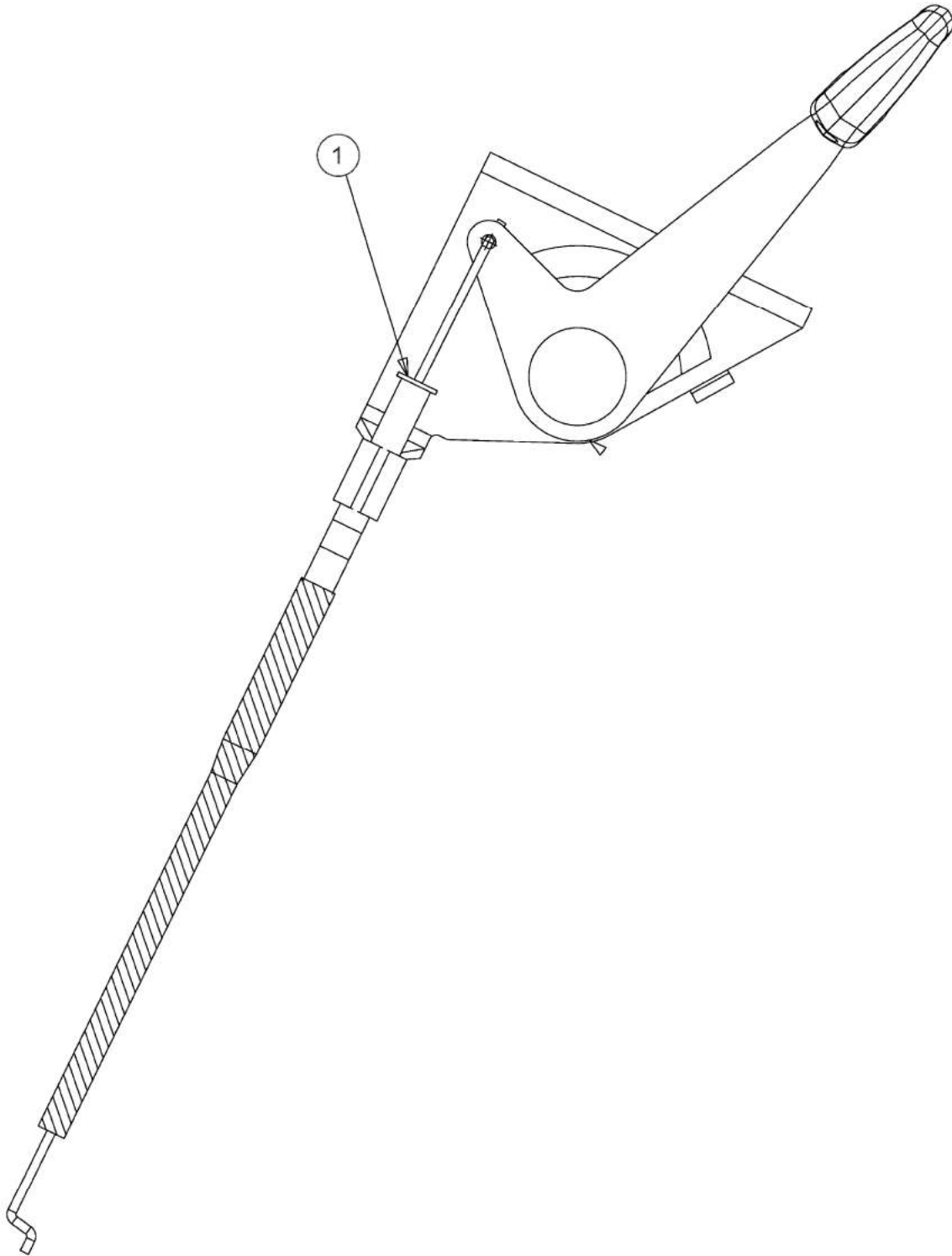

E3-11402A-01

Cable de gaz

Fig.	No. Pièces	Désignation	Numero de la norme	Nbr.
1	746-04591A		MIT BEDIENUNGSHEBEL	1

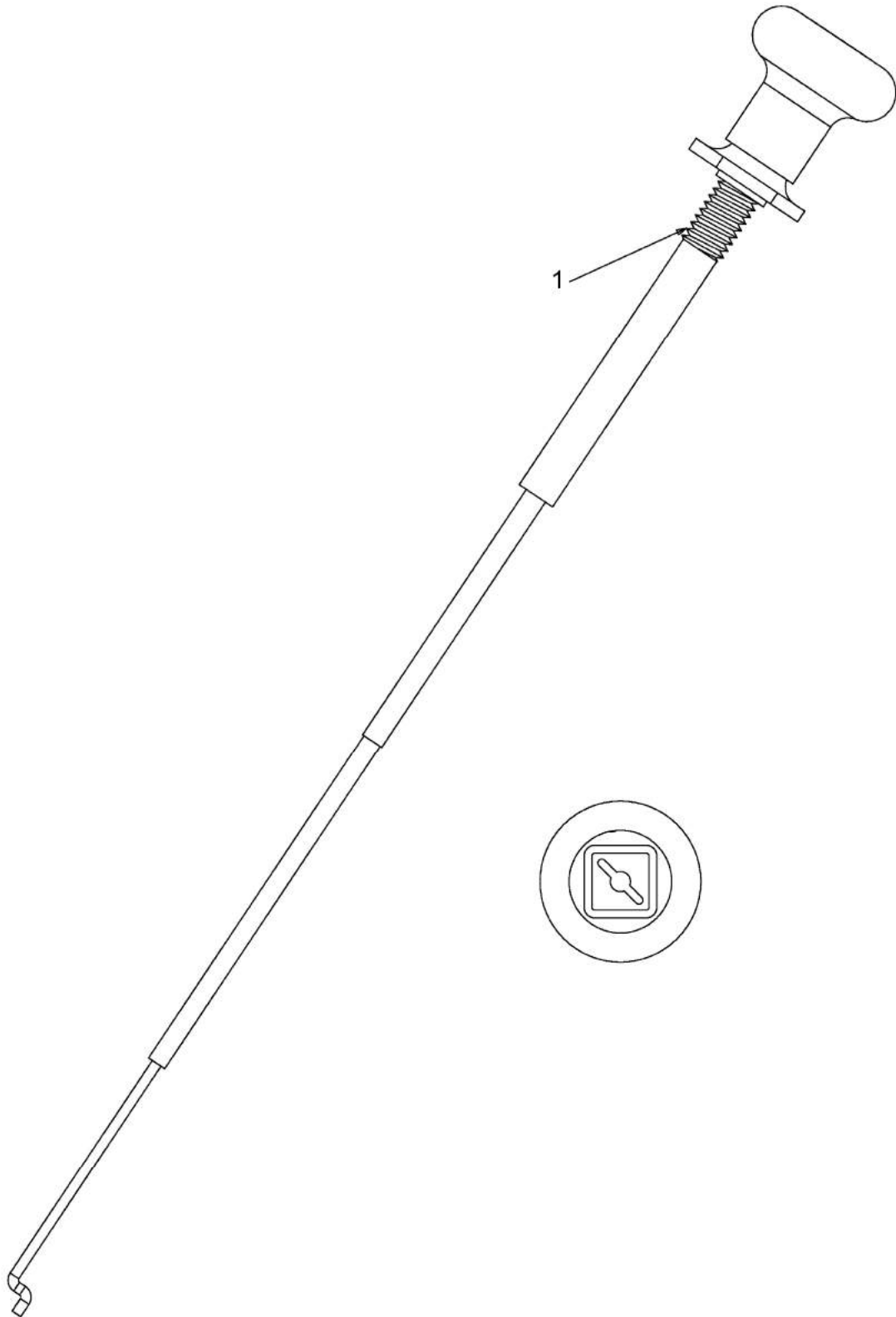

E3-08094A-01

Commande de choke

Fig.	No. Pièces	Désignation	Numero de la norme	Nbr.
1	746-04847	CABLE STARTER	FINISH:ZUGKNOPF SCHWARZ	1

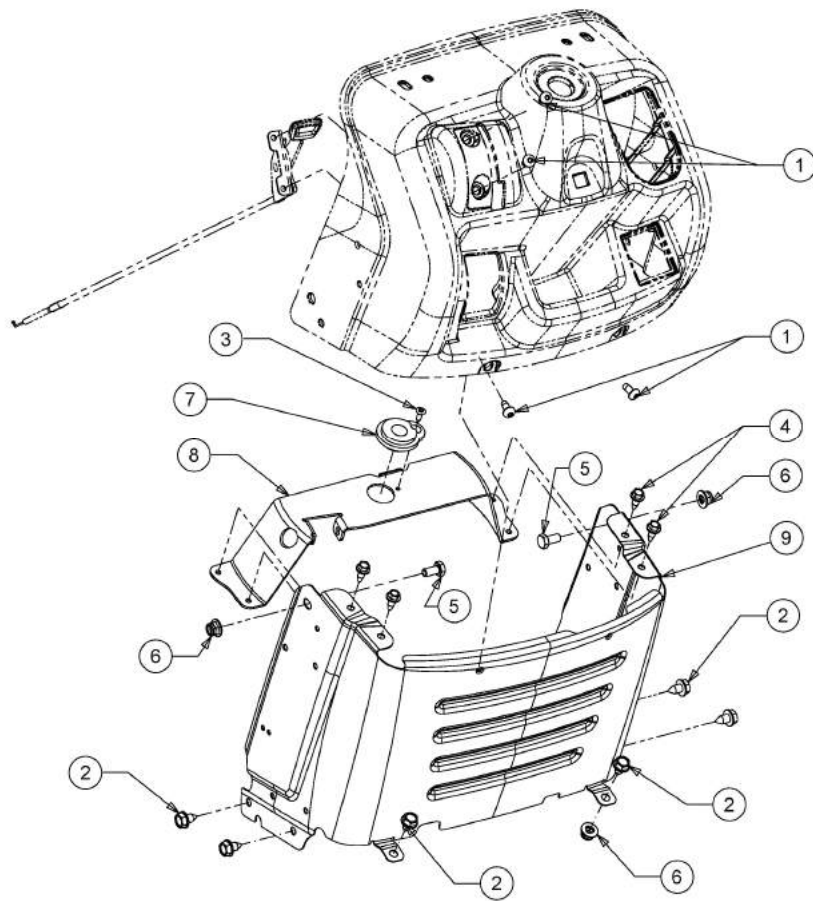

813-061151-11

Tableau de bord

Fig.	No. Pièces	Désignation	Numero de la norme	Nbr.
1	710-05070A	VIS	FINISH: SCHWARZ SPEC-000087	4
2	710-0604A	VIS 5/16-18:0.625	FINISH: MTD SPEC-100016 TYPE 1	6
3	710-0837	VIS	FINISH: MTD SPEC-100016 TYPE 1	1
4	710-1652	VIS HEX. TT:1/4-20:.625:HXINDW	FINISH: MTD-SPEC-100016 TYPE 1	4
5	710-3025	VIS	FINISH: MTD SPEC-100015	2
6	712-04063	ECROU HEX. AVEC FLANC	FINISH: MTD SPEC-100015	4
7	741-0587	SUPPORT	FINISH: NATUR	1
8	783-06785C-S	SUPPORT TABLEAU DE BORD	SCHWARZ	1
9	783-06811F-S	TABLEAU DE BORD INFERIEUR		1

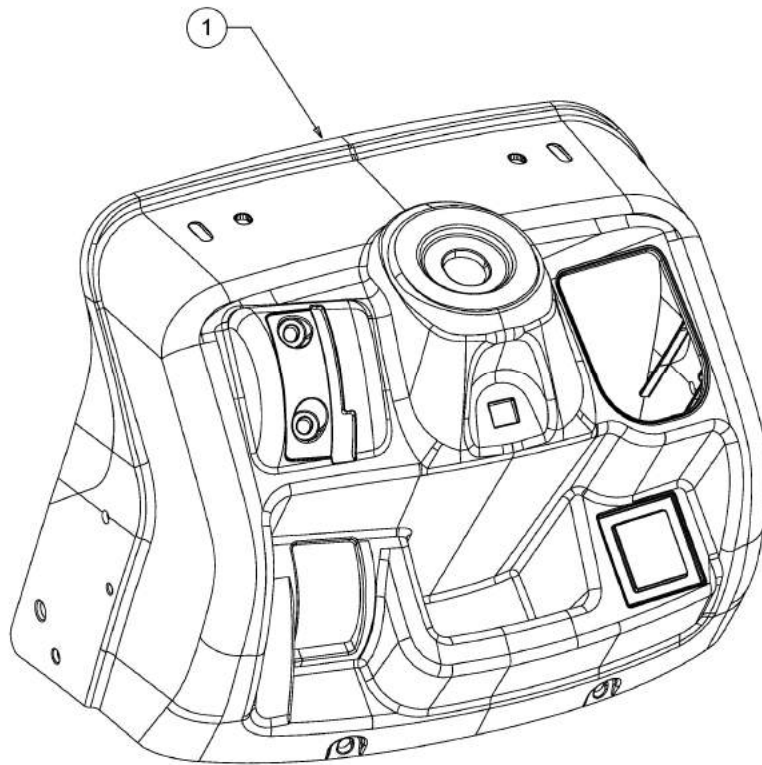

731-09942A-02

Tableau de bord pièce supérieure

Fig.	No. Pièces	Désignation	Numero de la norme	Nbr.
1	731-09942A	TABLEAU DE BORD	KUNSTSTOFF SCHWARZ	1

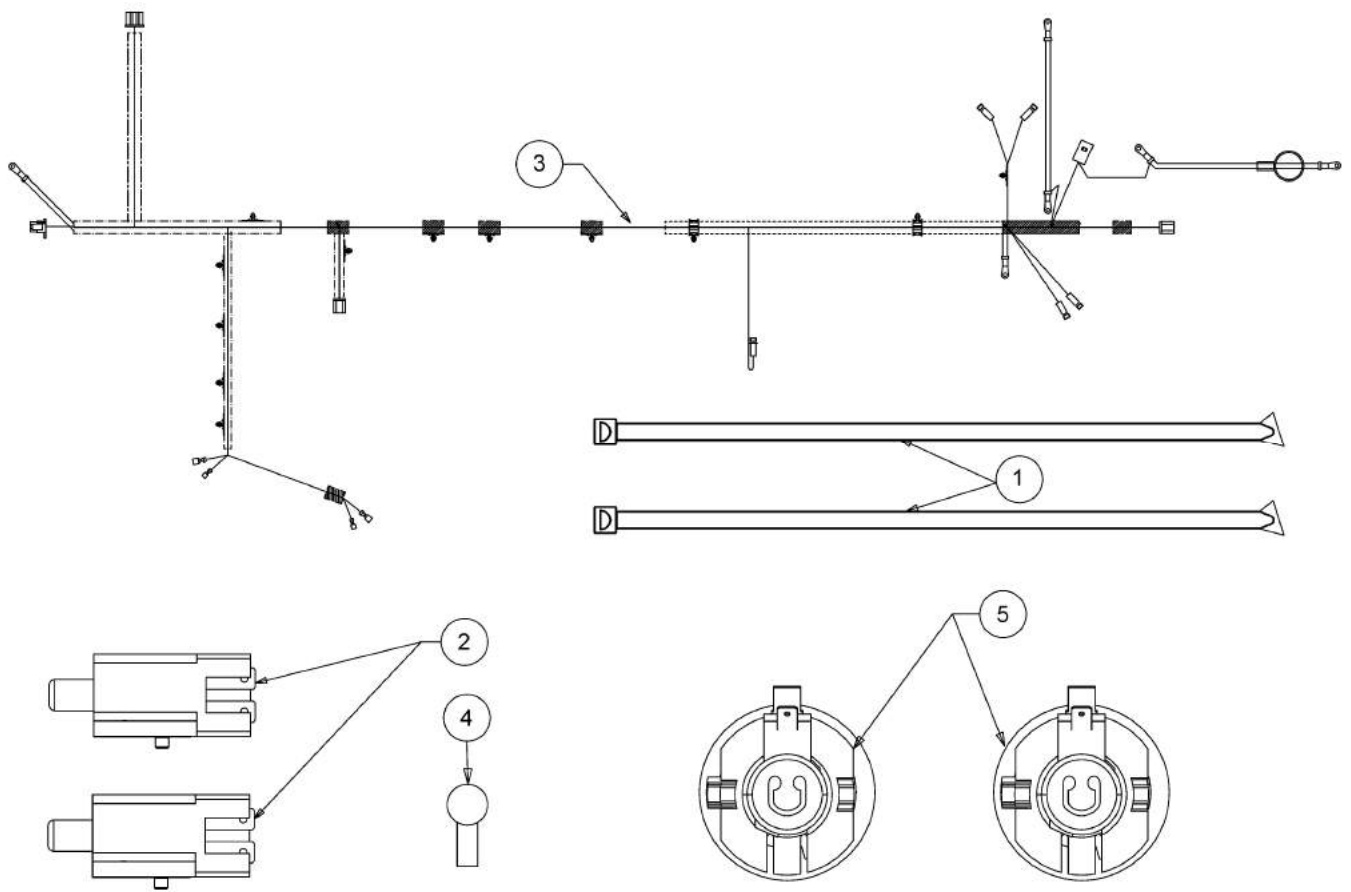

813-070820-01

Assortiment Úlectrique

Fig.	No. PiPces	DÚsignation	Numero de la norme	Nbr.
1	725-0157	COLLIER DE SERRAGE3/16X0.5X7.4	MATERIAL:NYLON-SCHWARZ	4
2	725-04363	SECURITE EMBRAYAGE	FINISH:SIEHE ZG.	2
3	725-18173A			1
3A	629-04133B	FAISCEAU DE PHARE	FINISH:	2
4	725-3237	COUVERCLE POLE / ROUGE	BATTERIE FINISH:ROT	1
5	725-1649A		KUNSTSTOFF GRAU	2

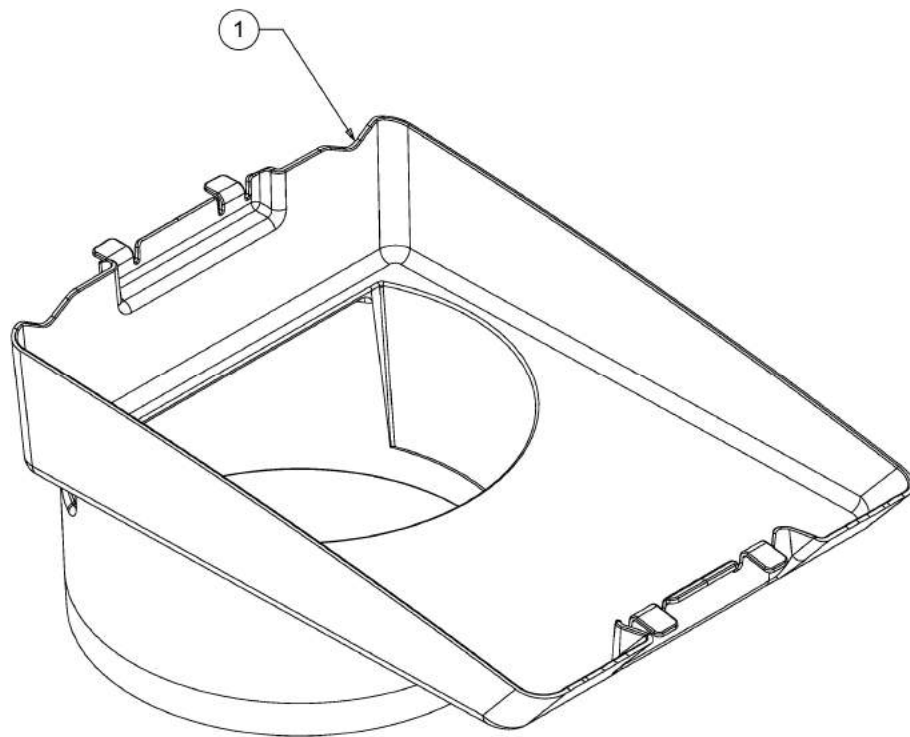

731-12705A-01

Conduit air

Fig.	No. Pièces	Désignation	Numero de la norme	Nbr.
1	731-12705A			1

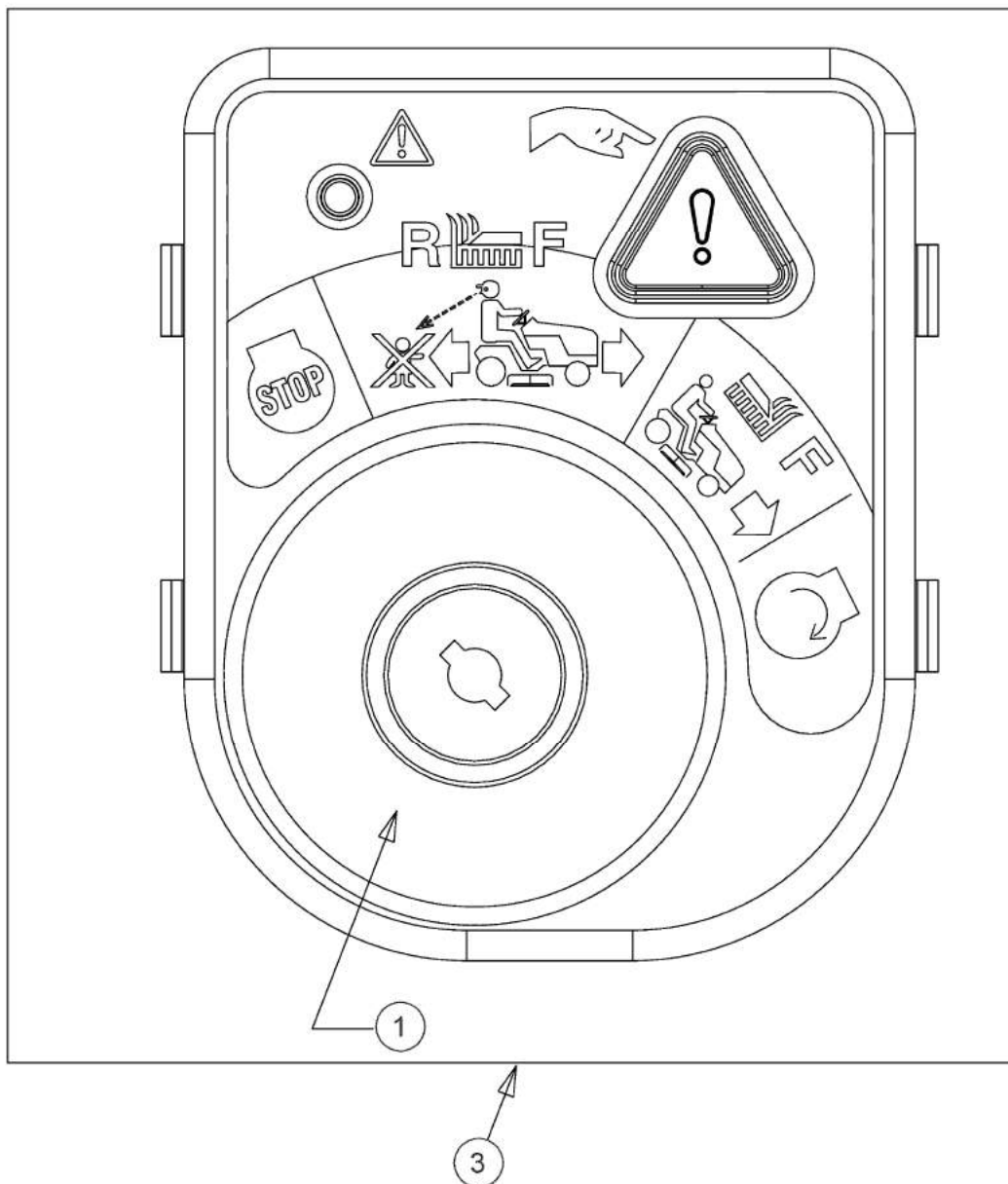

E3-11403A-01

Contacteur

Fig.	No. Pièces	Désignation	Numero de la norme	Nbr.
1	725-1741	CONTACTEUR A CLE	FINISH: 925-1741	1
3	725-06119C		FINISH:	1

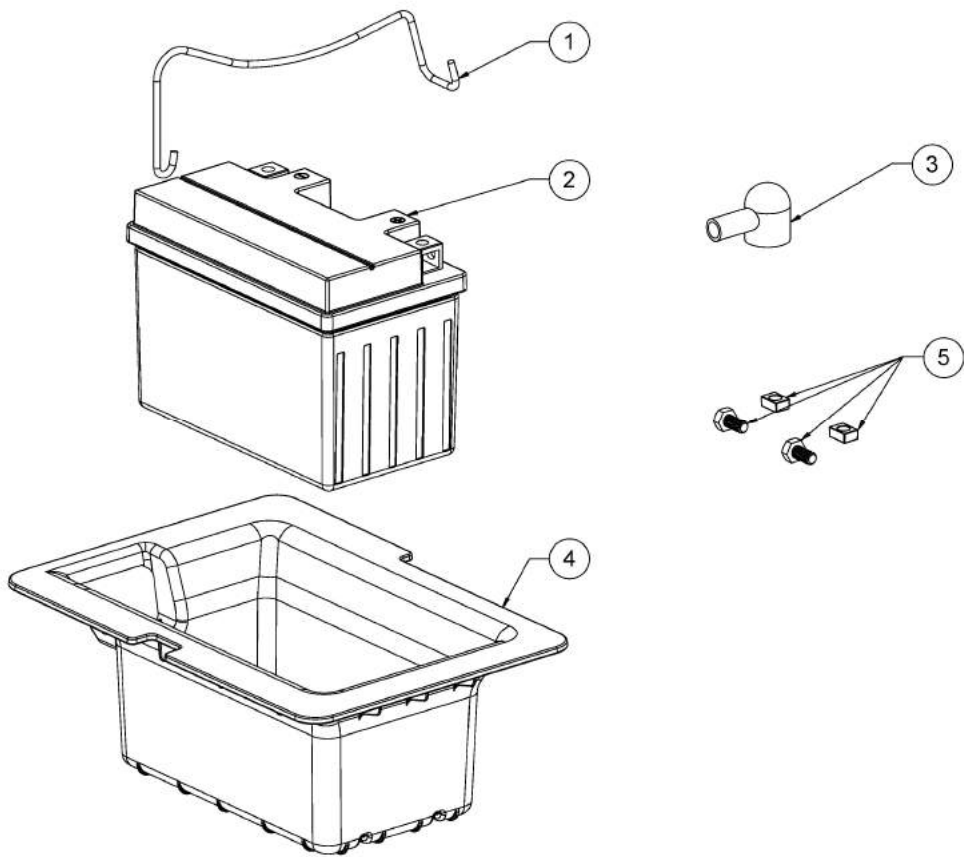

813-064059-02

Batterie

Fig.	No. Pièces	Désignation	Numero de la norme	Nbr.
1	683-04448637	TRINGLE SUPPORT BATTERIE	683-04448-0637	1
2	725-17335	BATTERIE 11AH	725-17335	1
3	725-3237	COUVERCLE POLE / ROUGE	BATTERIE FINISH:ROT	1
4	731-27025			1
5	753-11253			1