

BILL OF MATERIALS				
	PART DESCRIPTION	QTY	MATERIAL	COLOUR
1	HANDLE COVER	1	>ABS<	GREY RAL 7035
2	HANDLE	1	>PP+GF<	GREY RAL 7021
3	RIGHT SIDE	1	>PP<	GREEN RAL 6018
4	REEL SIDE	2	>PP<	GREY RAL 7021
5	RING NUT	2	>ABS<	GREY RAL 7021
6	SLIDING HANDLE	1	ALUMINIUM	\
7	REEL CROSS	2	>PP+GF<	GREY RAL 7021
8	WHEEL TUBE COVER	1	>PP<	GREY RAL 7021
9	WHEEL TUBE	1	STEEL	\
10	FRONTAL TUBE	1	ALUMINIUM	\
11	O-RING	2	>SILICONE<	GREEN RAL 6018
12	BRACKET	1	>PP<	GREY RAL 7021
13	LEFT SIDE	1	>PP<	GREEN RAL 6018
14	WASHER	1	>POM<	GREY RAL 7021
15	GASKET	1	>NBR<	BLACK
16	TAP ADAPTOR	1	>PP<	GREY RAL 7021
17	WHEEL	2	>PP<	GREY RAL 7021
18	WHEEL STOPPER	2	>PE<	GREEN RAL 6018
20	HOSE CONNECTOR	2	\	\

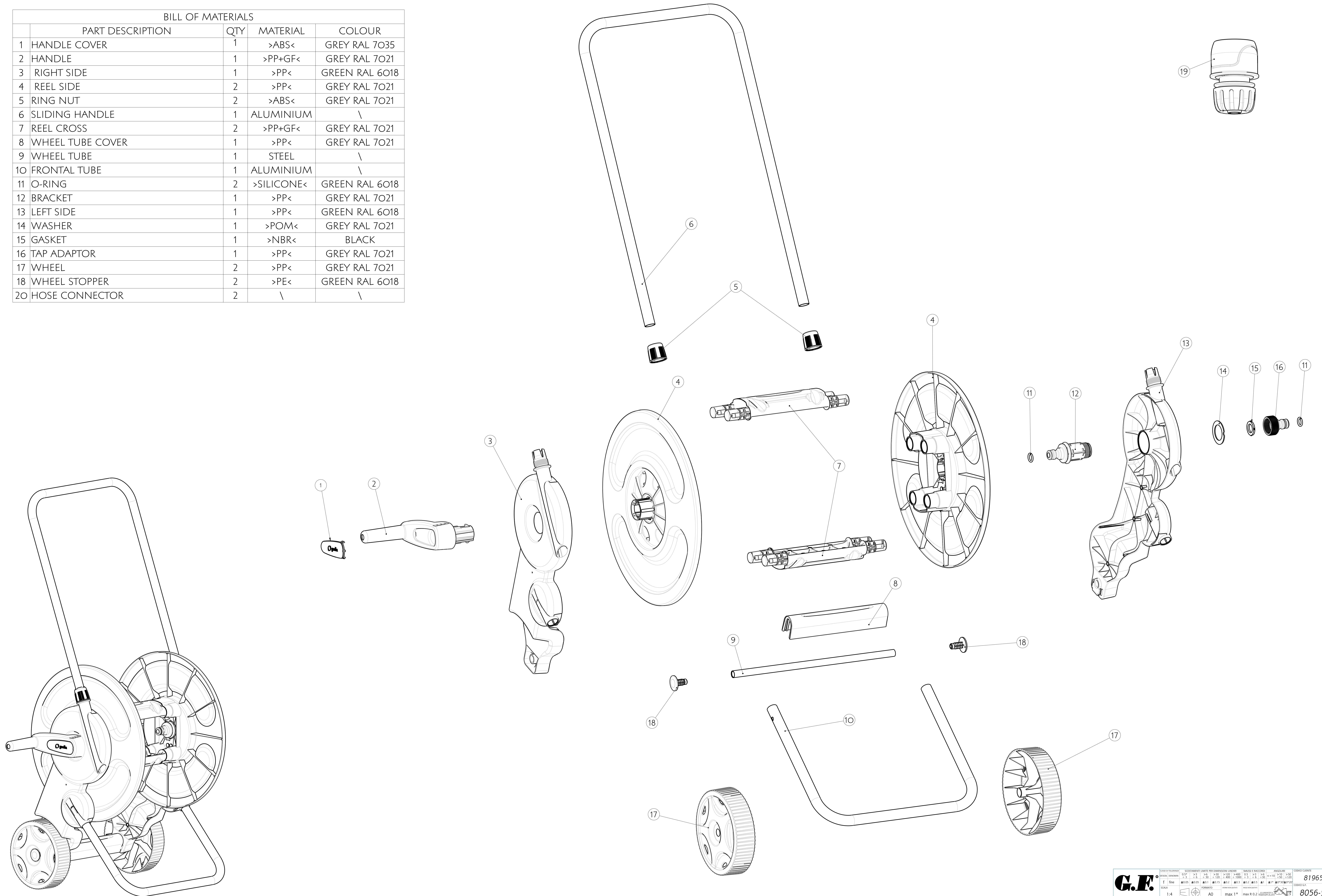

G.E.		SCALATURE LINEAR PER DIMENSIONI LINEARI		SARCOLE E ANCORAGGI		ANGOLI		CODICE CLIENTE	
ITALY		2, 3, 4, 5, 6, 7, 8, 9, 10, 11, 12, 13, 14, 15, 16, 17, 18, 19, 20		1, 2, 3, 4, 5, 6, 7, 8, 9, 10, 11, 12, 13, 14, 15, 16, 17, 18, 19, 20		1, 2, 3, 4, 5, 6, 7, 8, 9, 10, 11, 12, 13, 14, 15, 16, 17, 18, 19, 20		81955693	
COSTRUZIONE STAMPA STAMPAGGIO AD INIEZIONE TECNOPOLIMERI		MATERIALE		TRATTAMENTO		CODICE G.L.		CODICE EAN	
CORREGGIO (RE)		AO		max 1°		3276000411307		8056-5828	
ITALY		HOSE CART WITH TELESCOPIC HANDLE		PESO KG		NUMERO DISEGNO		REVISIONI	
E' VIETATO L'USO E LA RIPRODUZIONE DEL PRESENTI DISEGNO SENZA AUTORIZZAZIONE SCRITTA		AND 50m 15mm MINI CAPACITY GEOLIA		VOLUME EURO		FOGGIO		1 1 1	
DISEGNATO		APPROVATO		DATA		DIRETTORE		REVISIONI	
M. B.		P. B.		2007-18		G. B.		00	

DESCRIZIONE: BOCCHETTA