

A

B

C

D

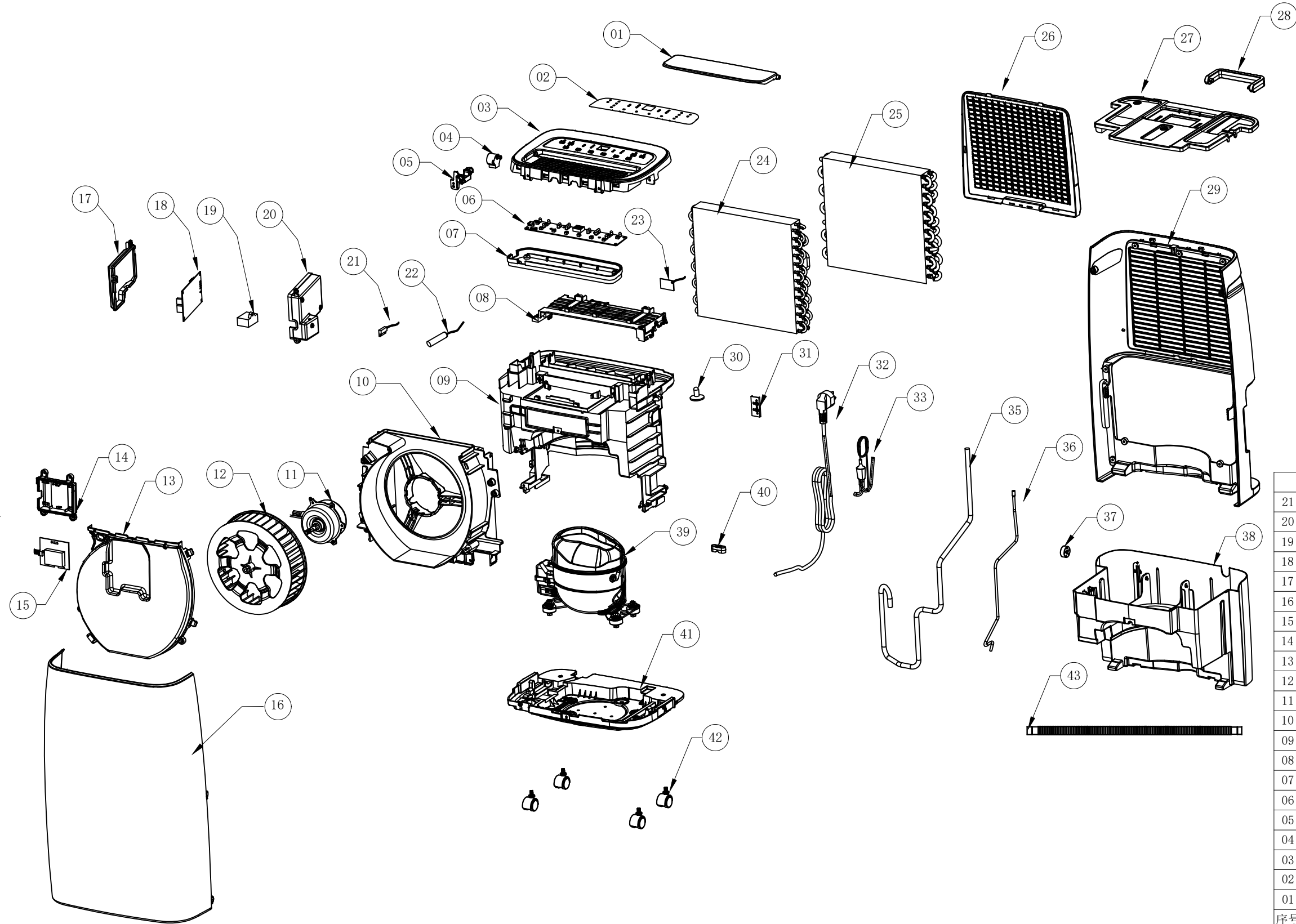

		43	Water pipe
21	Magnetic Switch	42	Castor
20	Electric Box Cover	41	Base
19	Fan Capacitor	40	Wire Clamp
18	Power PCB	39	Compressor
17	Electric Box	38	Water Tank
16	Front Panel	37	Magnet
15	Hidden Display PCB	36	Discharge Pipe
14	Hidden Display Cover	35	Suction Pipe
13	Duct Cover		
12	Fan	33	Capillary
11	Fan motor	32	Power Cord
10	Air Duct	31	Earth Panel
09	Main Frame	30	Water Stopper
08	Heat Exchanger Fix	29	Back Cover
07	Display Cover	28	Water Tank Handle
06	Display PCB	27	Water Tank Cover
05	Step Motor Support	26	Up Grille
04	Step Motor	25	Evaporator
03	Top Cover	24	Condenser
02	Control Mask	23	Humidity Sensor
01	Louver	22	Tube Temp. Sensor
序号	物料名称	序号	物料名称

					D008机型			江门市 宝士制冷电器有限公司	
标记	处数	更改内容	签名	年.月.日					
视图	≡ ⊕	审核			阶段	标记	重量	比例	爆炸图
设计		工艺							
制图		标准化							
校对		批准			共张	第张	编码	D008A-20L	

1

2

3

4