

# Technical drawings with tolerances

L2 range

**HIGH RESIN CABINET 68 CM/CONV**

**MATRIX ID - 2022R14P02-0006**

**Gtin 13: 3276007359190**



HIGH RESIN CABIENT 68 CM/CONV  
MATRIX ID - 2022R14P02-0006

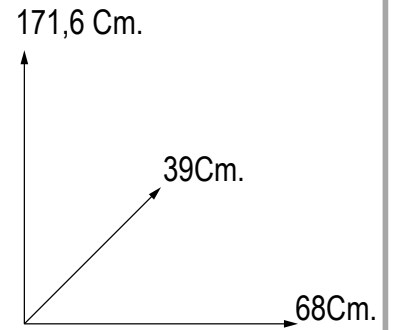

Tolerance on overall dimensions: +/- 10 mm

Overall gross weight (including packaging) : 15.500 gr with tolerance of +/- 5%

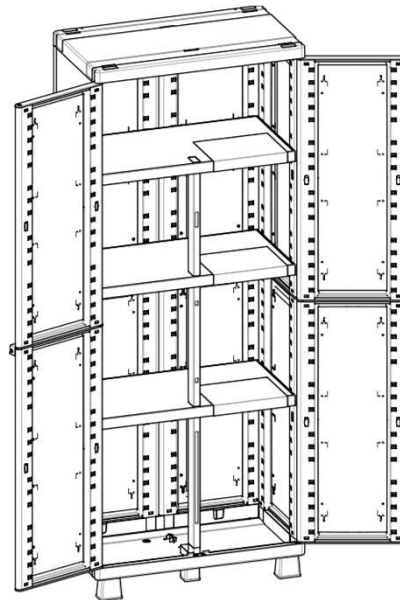
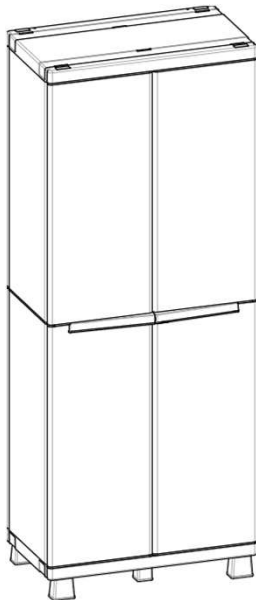

# Exploded View

HIGH RESIN CABINET 68 CM/CONV

MATRIX ID - 2022R14P02-0006

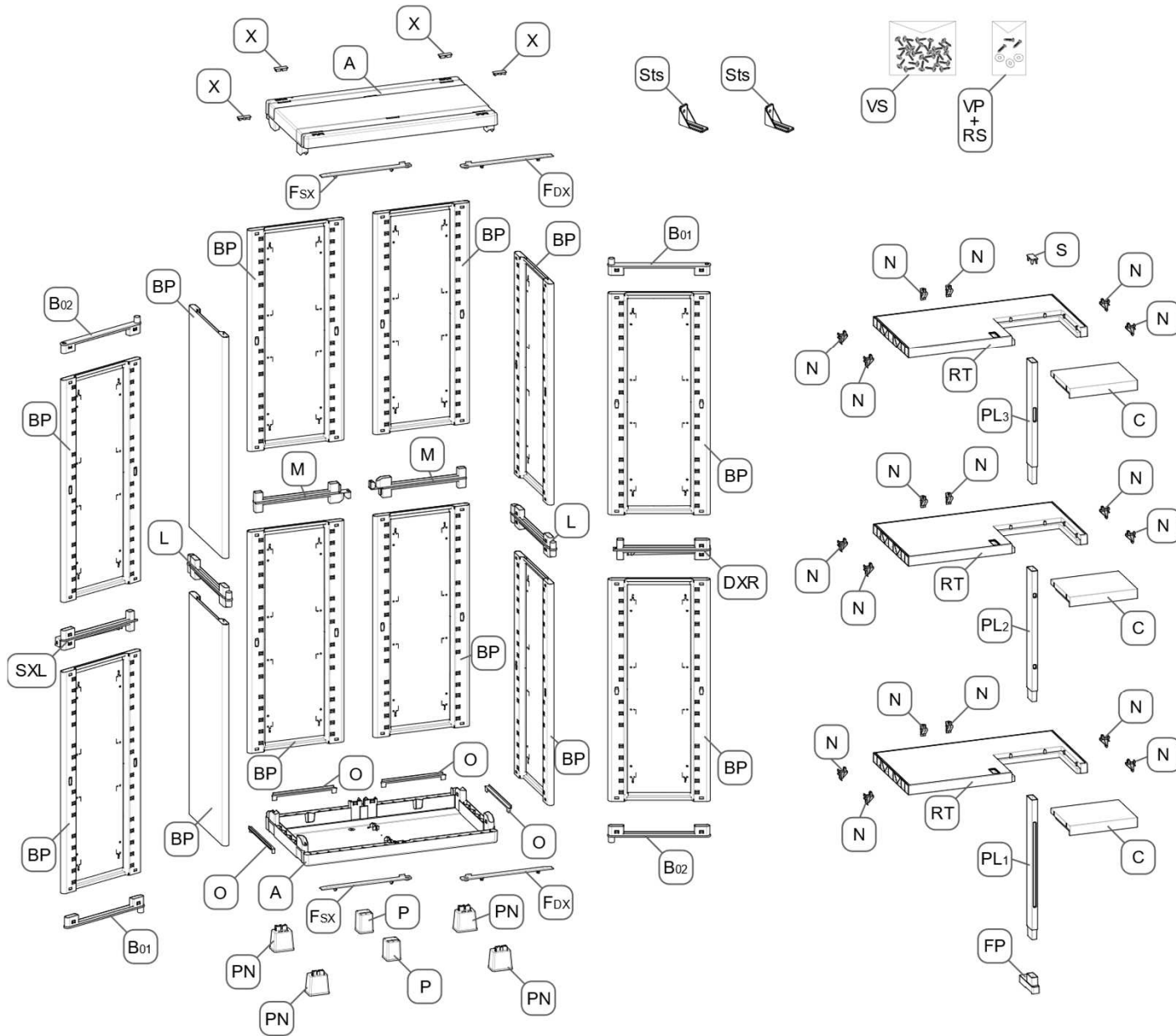

- Material shrinkage coefficient (PP): 1.8%
- Tolerance on indicated dimensions: +/- 0,5 mm
- Texture: Same of other molds of the same product family
- Color: black PP (4000022)
- Color: grey PP (4000024)

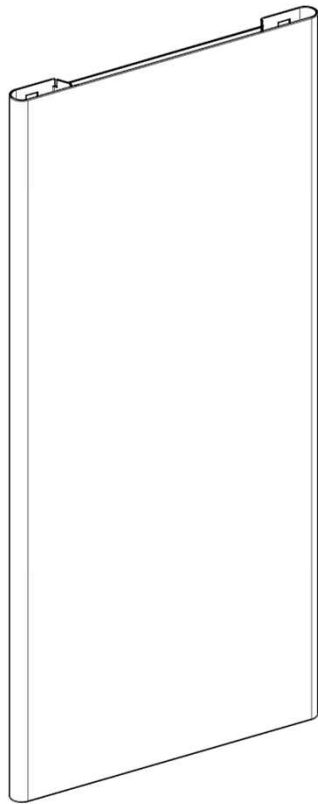

Assonometria

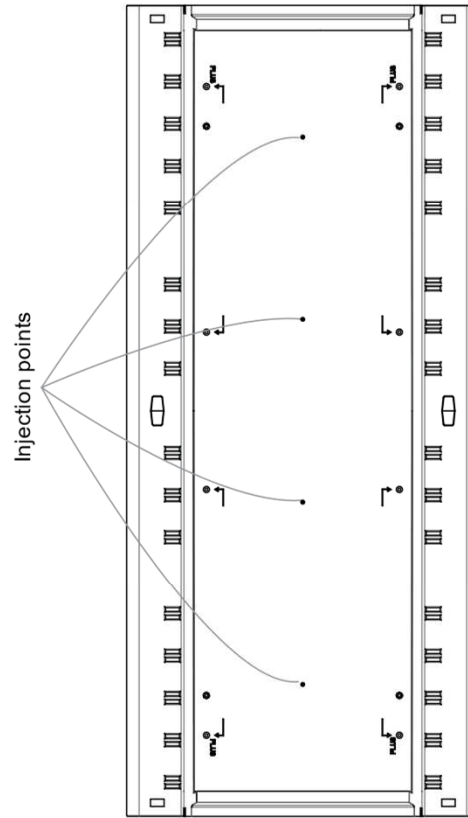

Injection points

Retro

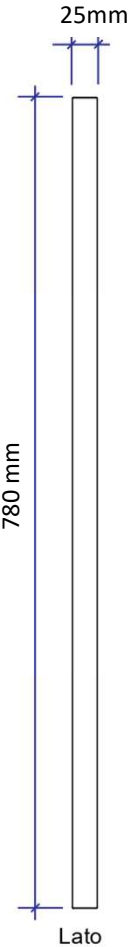

25mm

780 mm

Lato

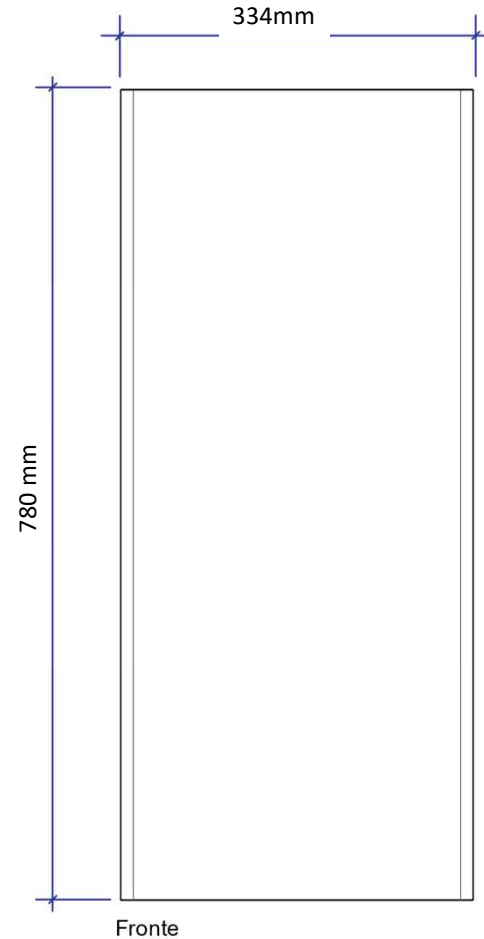

334mm

780 mm

Fronte



Sotto

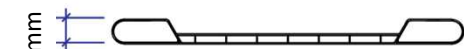

25mm

Sopra

**BP**

**New Panel J-flat (BP)**

- Material shrinkage coefficient (PP): 1.8%
- Tolerance on indicated dimensions: +/- 0,5 mm
- Texture: Same of other molds of the same product family
- Color: black PP (4000022)

Injection points

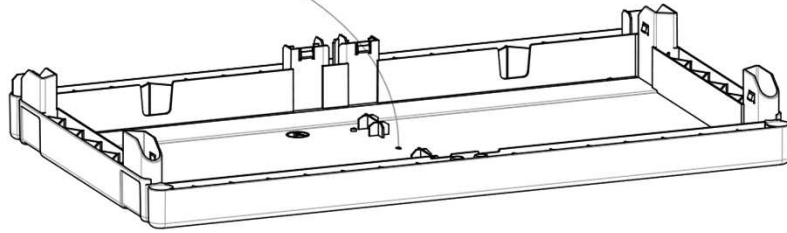

Assonometria BOTTOM

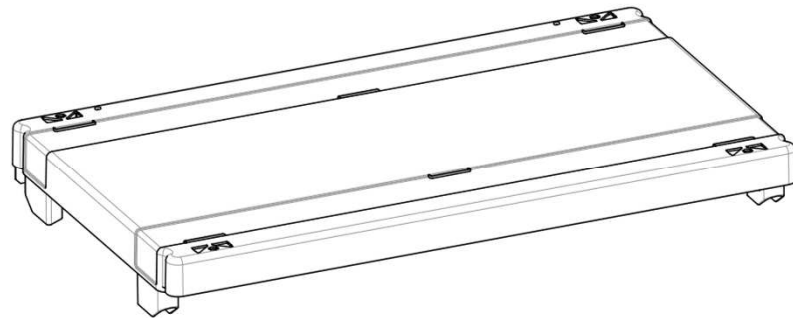

Assonometria TOP

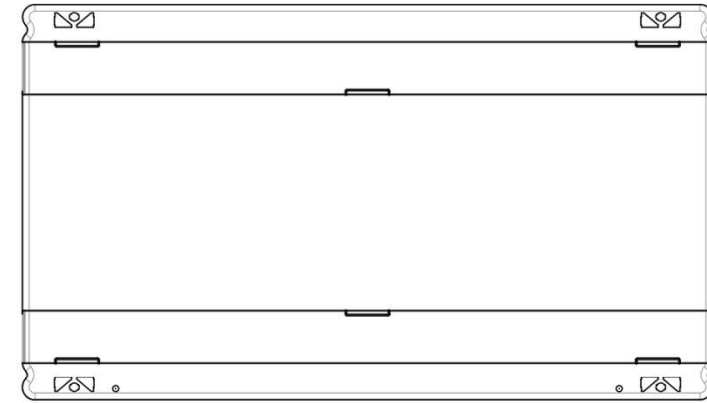

Sotto

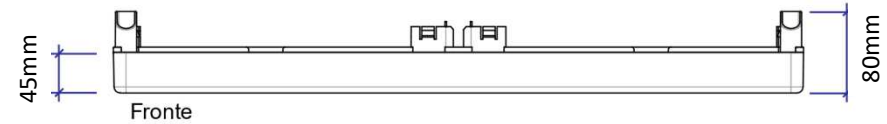

Fronte

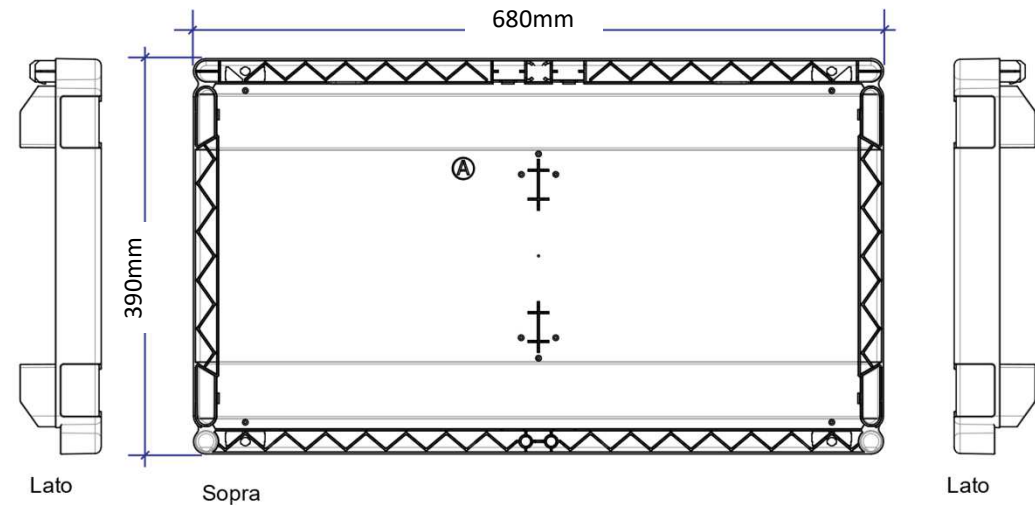

Lato

Sopra

Lato

**A**

**TOP/BOTTOM – CAB 268 (A)**

## Kit of 4 Hinges (B01 + B02)

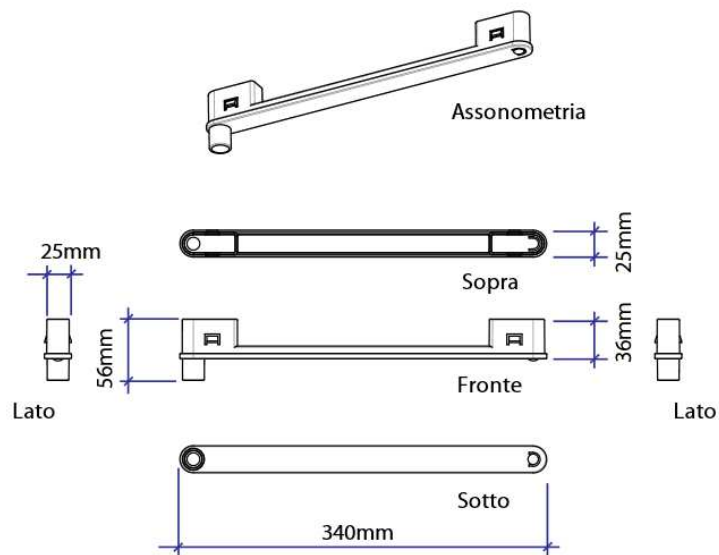

B01

- Material shrinkage coefficient (PP): 1.8%
- Texture: Same of other molds of the same product family
- Color: black PP (4000022)

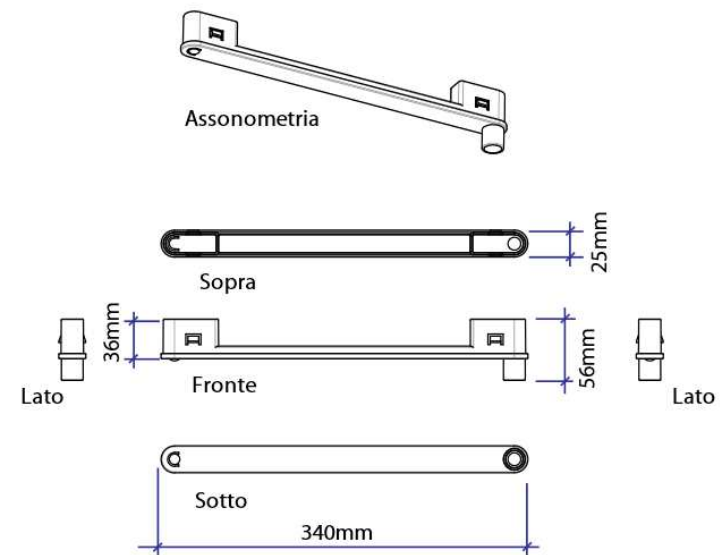

B02

- Material shrinkage coefficient (PP): 1.8%
- Texture: Same of other molds of the same product family
- Color: black PP (4000022)

**BELT KIT (SX+DX+L+M)**

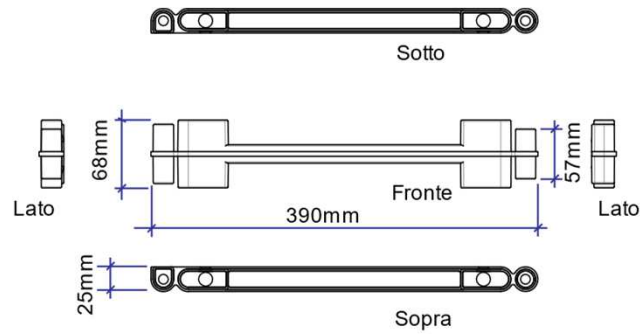

**L**

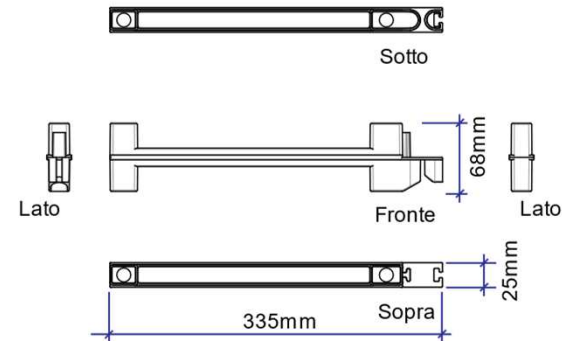
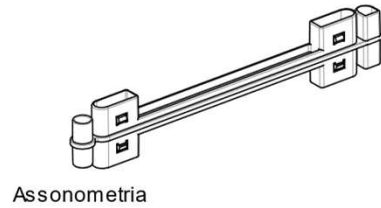

**M**

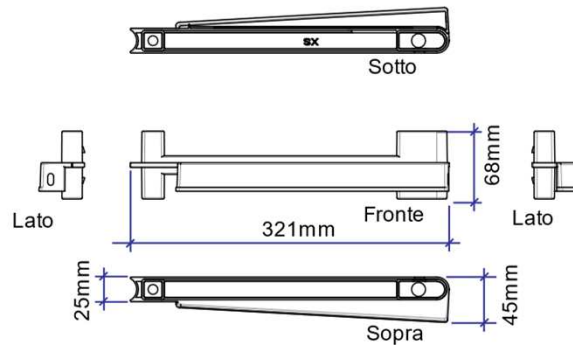
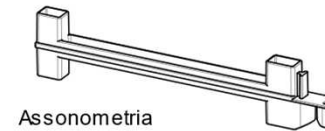

**SXL**

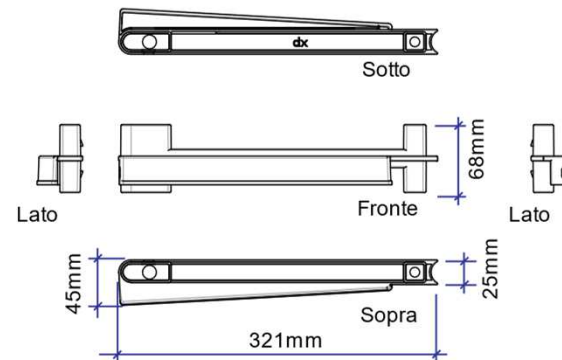
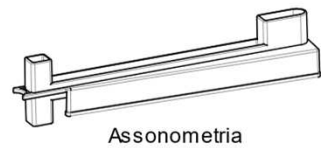

**DXR**

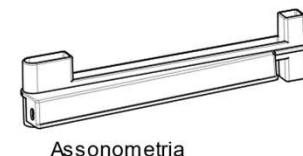

- Material shrinkage coefficient (PP): 1.8%
- Texture: Same of other molds of the same product family
- Color: black PP (4000022)

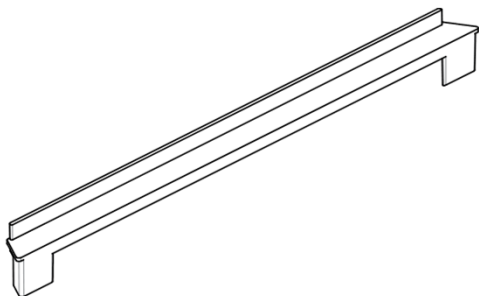

Assonometria

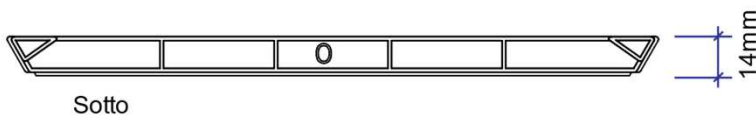

Sotto

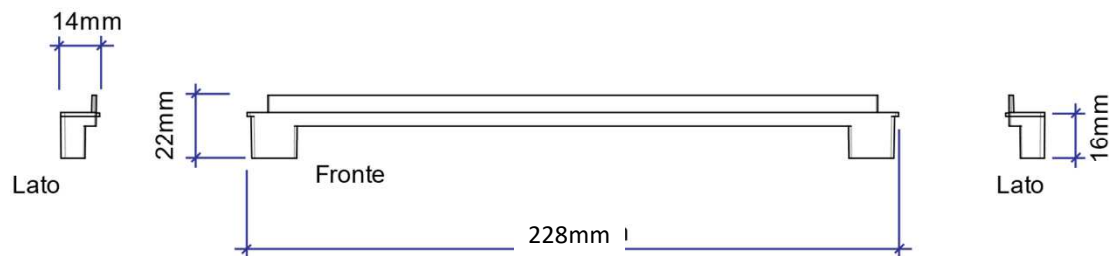

Lato

Fronte

Lato



Sopra

**O**

**Kit of 4 small strips (O)**

- Material shrinkage coefficient (PP): 1.8%
- Texture: Same of other molds of the same product family
- Color: black PP (4000022)



Assonometria

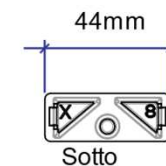

Sotto



Lato

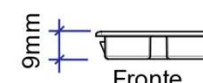

Fronte

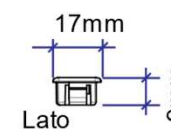

Lato

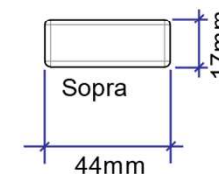

Sopra

**X**

**Kit of Cab Caps (X)**



- Material shrinkage coefficient (PP): 1.8%
- Texture: Same of other molds of the same product family
- Color: black PP (4000022)

## Kit of strips for Cab (Fdx- Fsx)

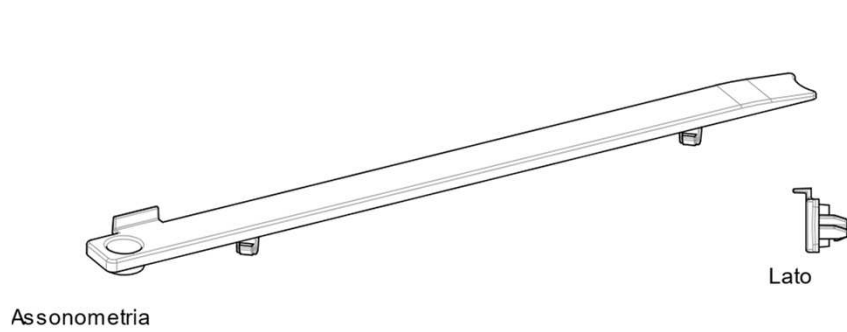

**FDX**

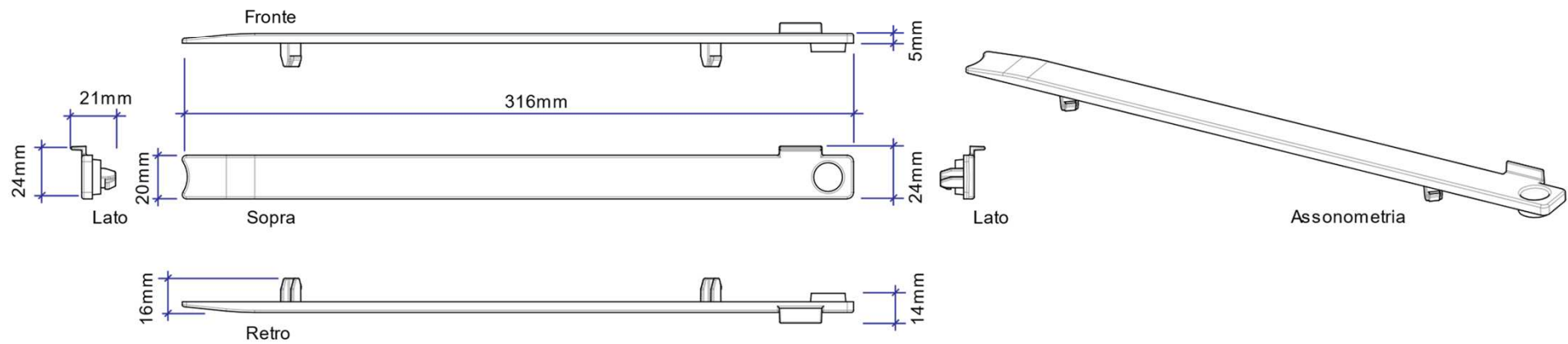
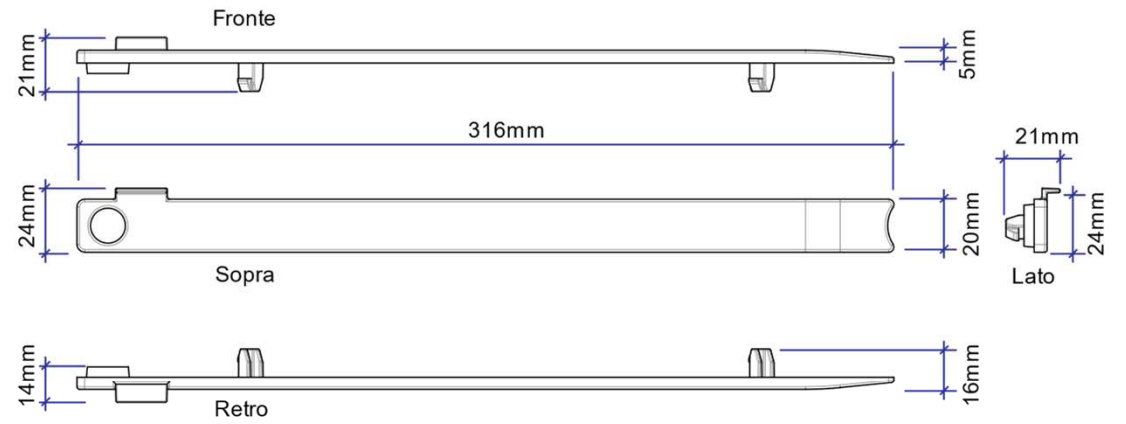

**FSX**

- Material shrinkage coefficient (PP): 1.8%
- Texture: Same of other molds of the same product family
- Color: black PP (4000022)

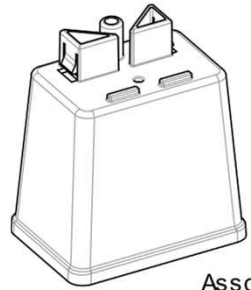

Assonometria

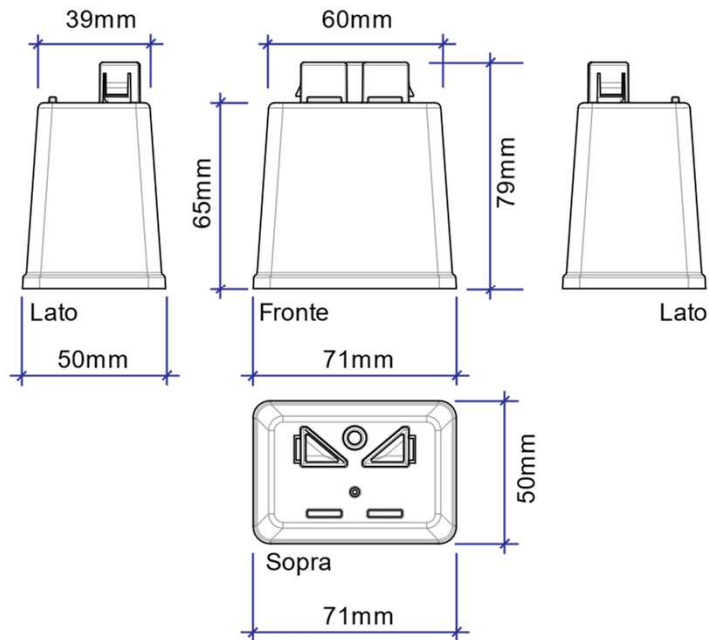

**PN**

**Kit Cab feet (PN)**

- Material shrinkage coefficient (PP): 1.8%
- Texture: Same of other molds of the same product family
- Color: black PP (4000022)

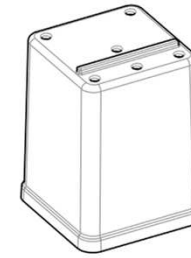

Assonometria

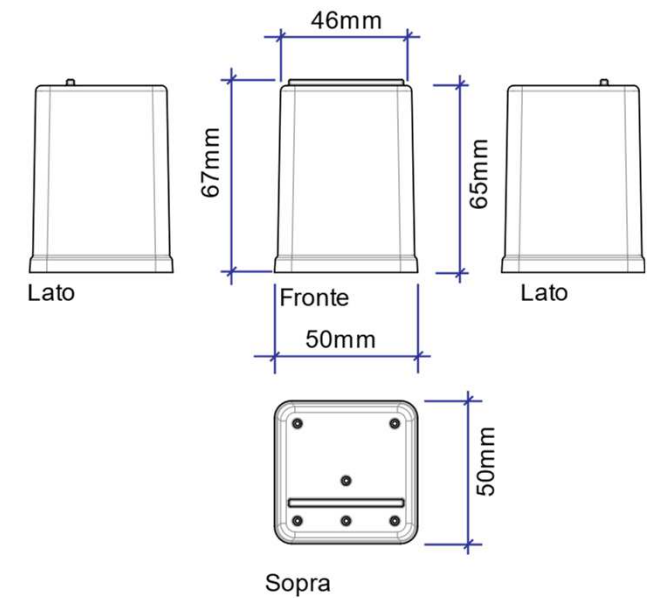

**P**

**2 STD Cab feet kit (P)**

- Material shrinkage coefficient (PP): 1.8%
- Texture: Same of other molds of the same product family
- Color: black PP (4000022)

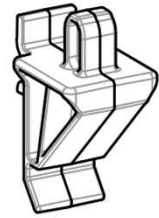

Assonometria

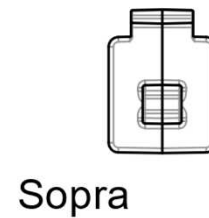
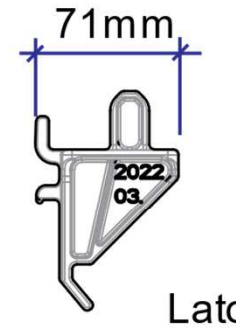
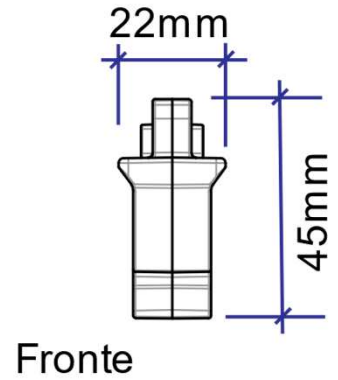
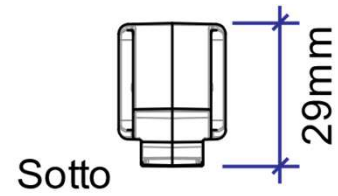

**N**

**Inner Shelf holders kit (N)**

## Poles & Base kit for Cab Convertible (PL+FP)

- Material shrinkage coefficient (PP): 1.8%
- Texture: Same of other molds of the same product family
- Color: black PP (4000022)

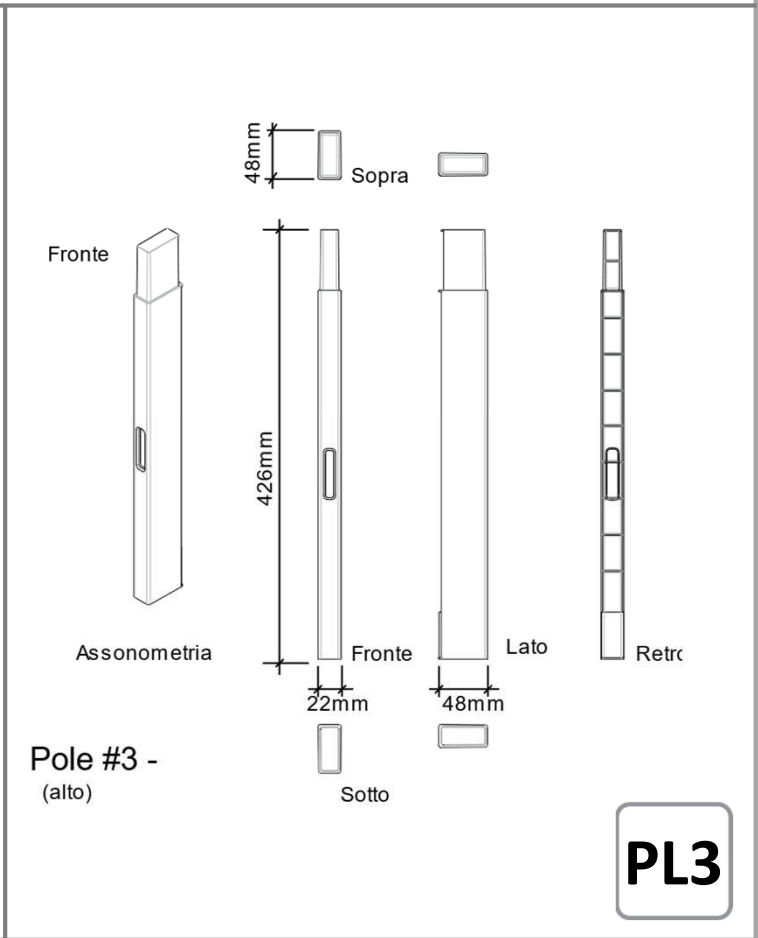
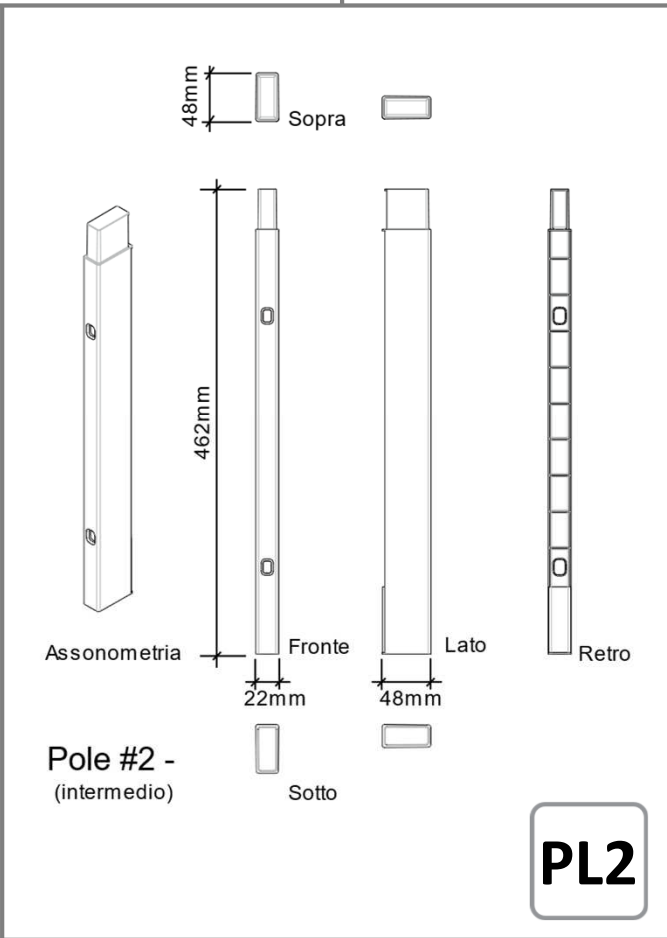
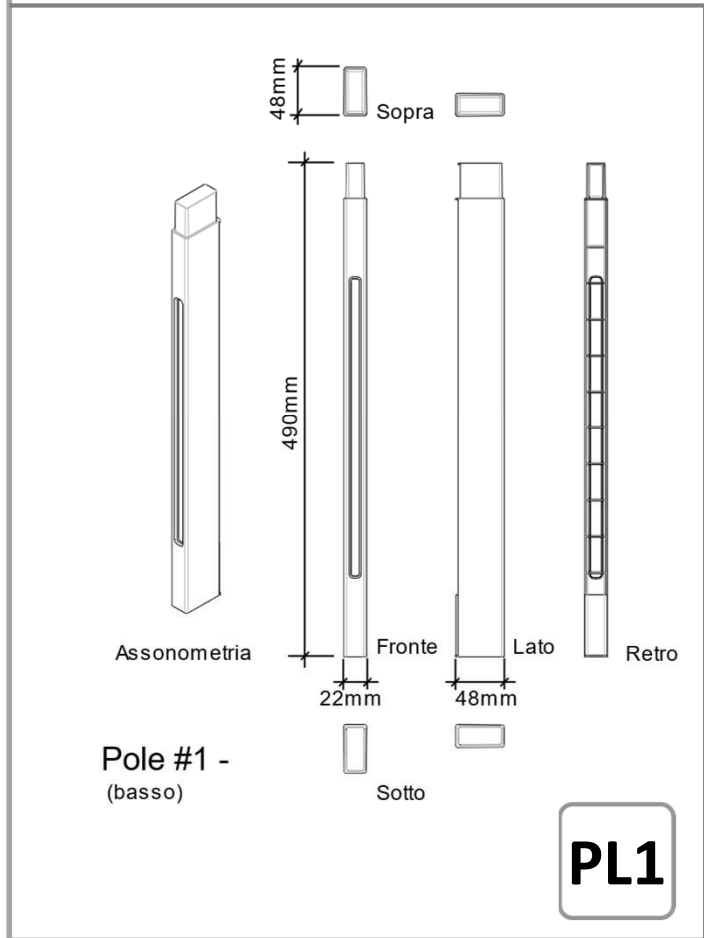
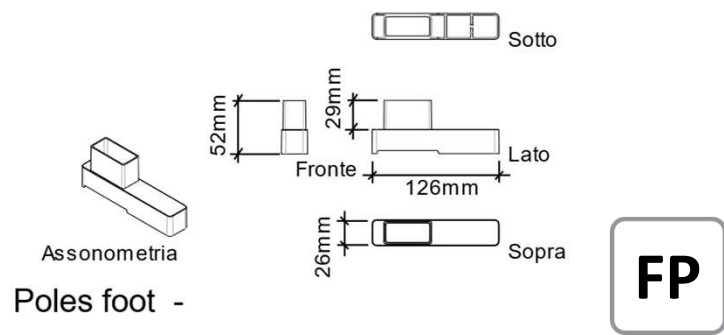

- Material shrinkage coefficient (PP): 1.8%
- Tolerance on indicated dimensions: +/- 0,5 mm
- Texture: Same of other molds of the same product family
- Color: black PP (4000022)

## New convertible inner shelf cab (RT+S)

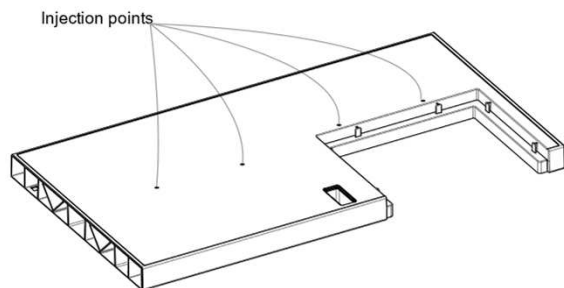

Assonometria

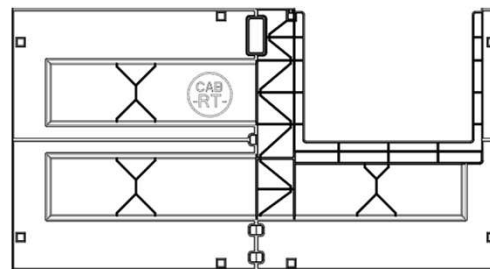

Sotto



Fronte

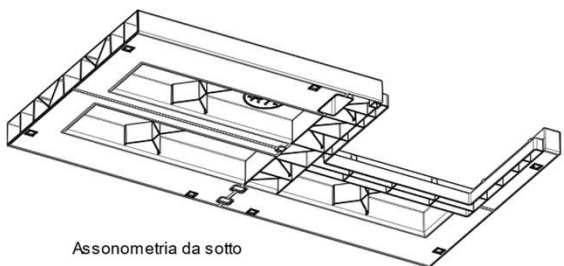

Assonometria da sotto



Lato

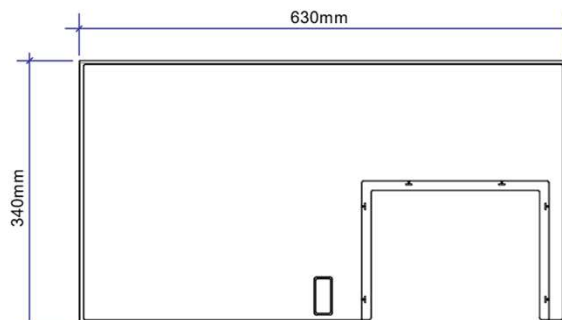

Sopra



Lato



Retro

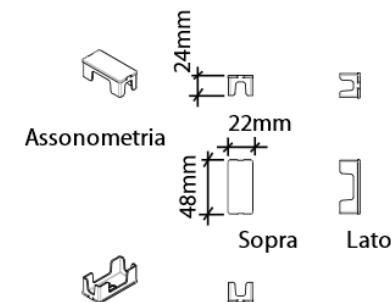

Top cap - Inner shelf

RT

S

- Material shrinkage coefficient (PP): 1.8%
- Texture: Same of other molds of the same product family
- Color: black PP (4000022)

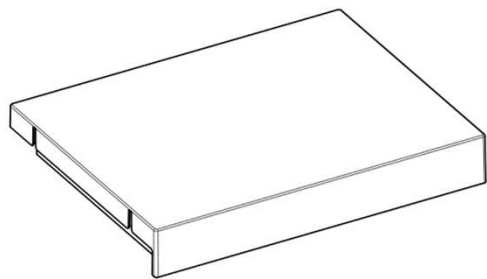

Assonometria

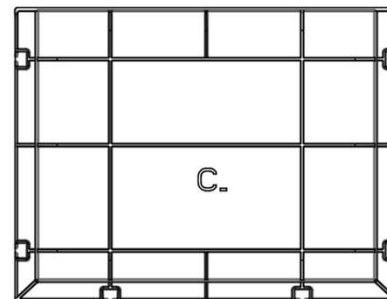

Sotto

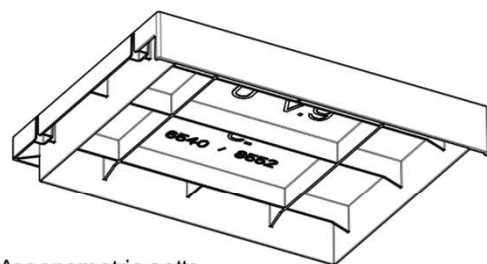

Assonometria sotto

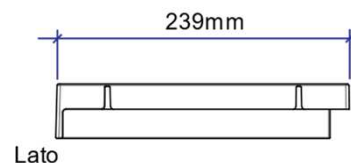

Lato

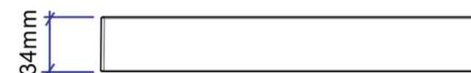

Fronte

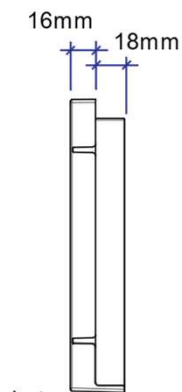

Lato

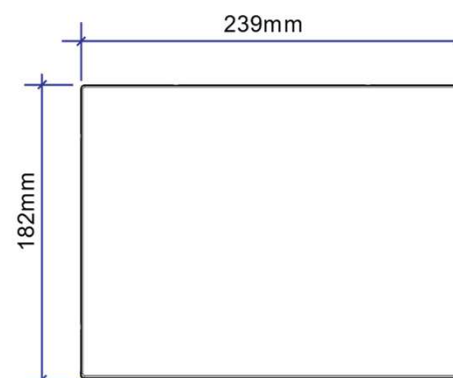

Sopra

C

**New convertible inner shelf insert (UC)**