

Technical drawings with tolerances

L3 range

LOW RESIN CABINET 65 CM

MATRIX ID - 2022R14P02-0014

Gtin 13: 3276007359220

LOW RESIN CABINET 65 CM

2022R14P02-0014



94m.

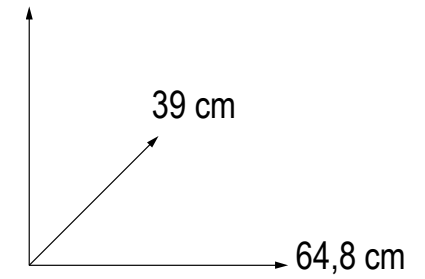

Tolerance on overall dimensions: +/- 10 mm

Overall gross weight (including packaging) : 8.000 gr with tolerance of +/- 5%

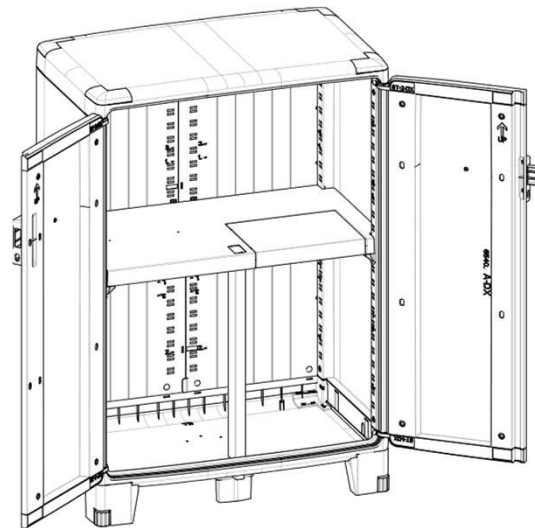
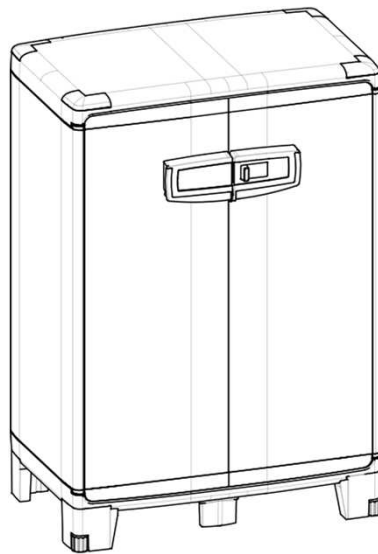

Exploded View

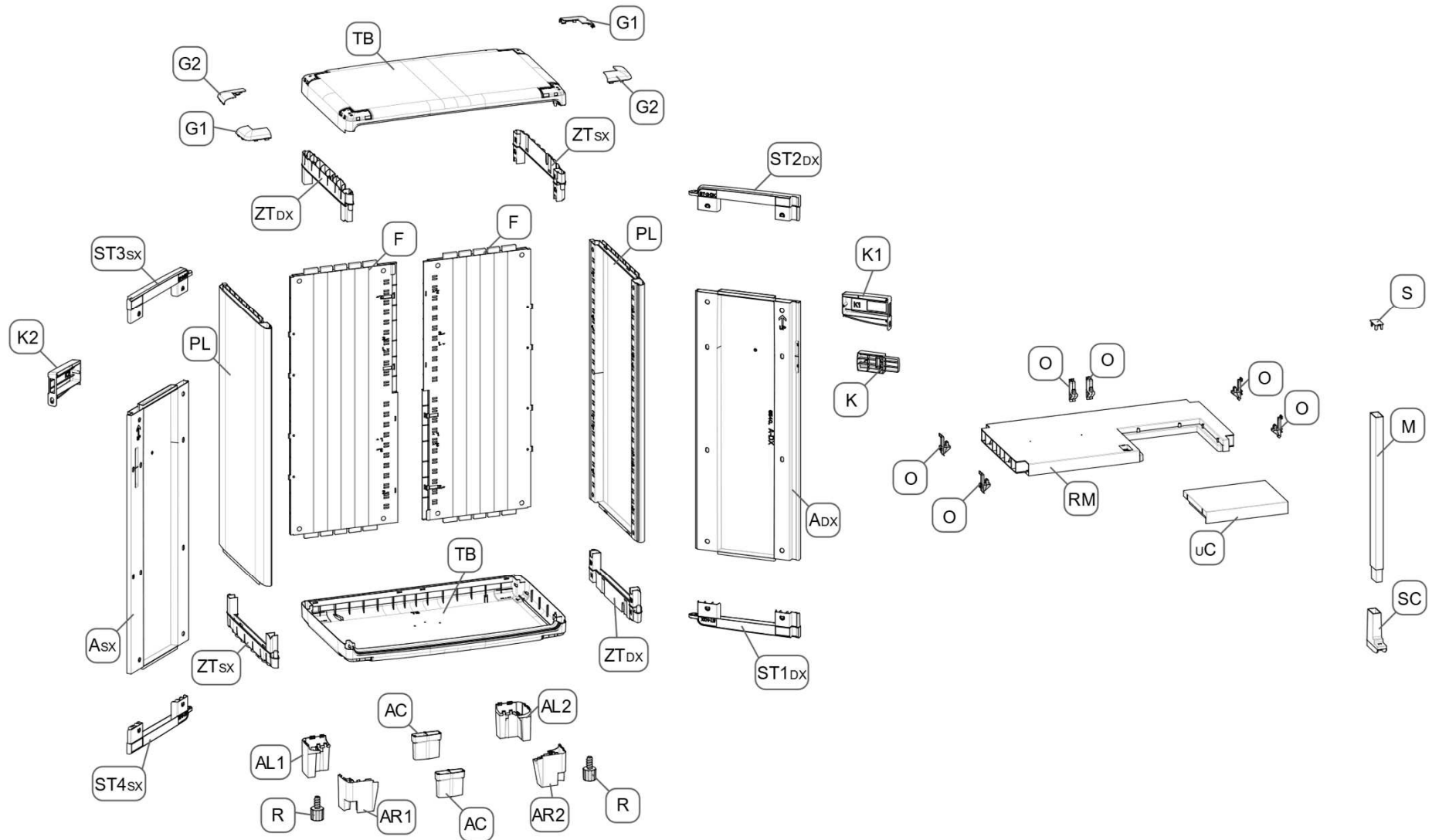
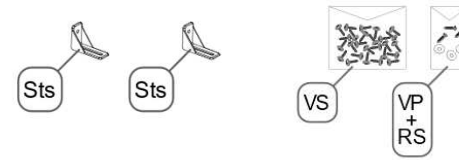

- Material shrinkage coefficient (PP): 1.8%
- Tolerance on indicated dimensions: +/- 0,5 mm
- Texture: Same of other molds of the same product family
- Color: grey PP (4000024)

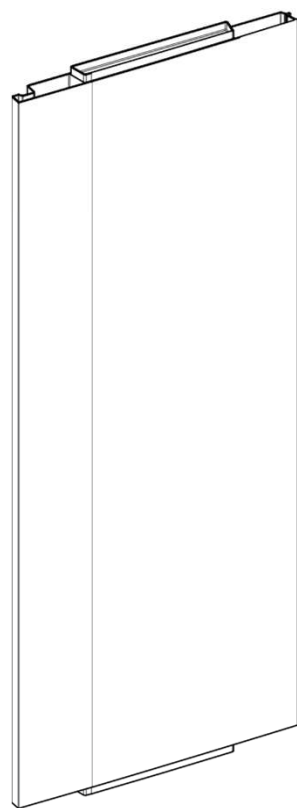

Assonometria

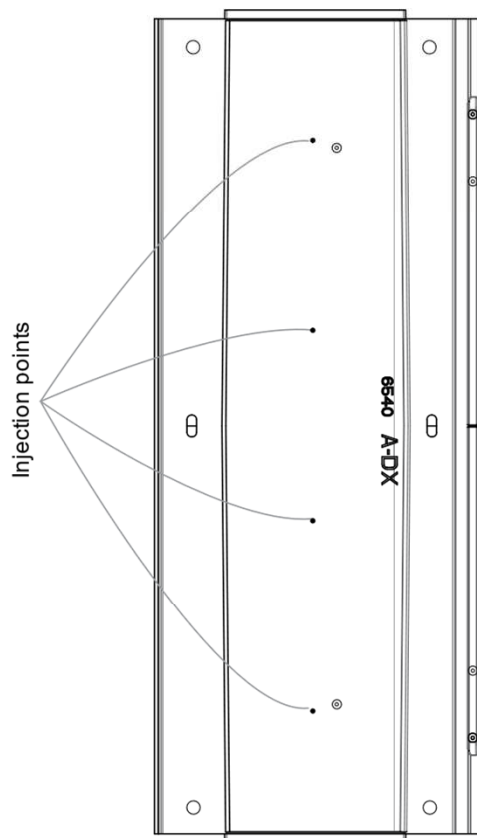

Injection points

6540 A-DX

Retro

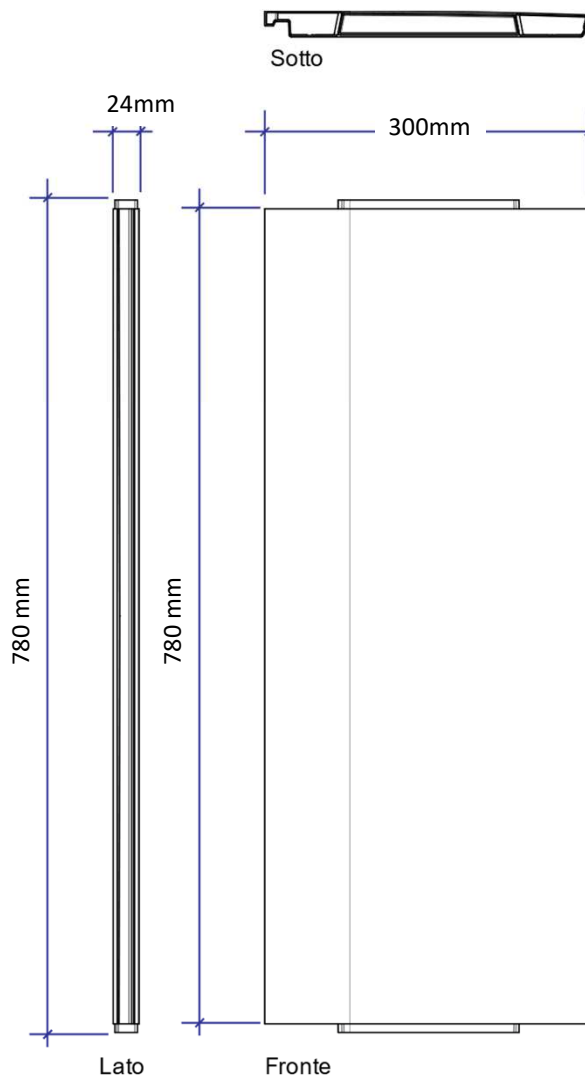

Sotto

24mm

300mm

780 mm

780 mm

Lato

Fronte

24mm

Sopra

ADX

KIT FRONT PANEL 65 Adx

- Material shrinkage coefficient (PP): 1.8%
- Tolerance on indicated dimensions: +/- 0,5 mm
- Texture: Same of other molds of the same product family
- Color: grey PP (4000024)

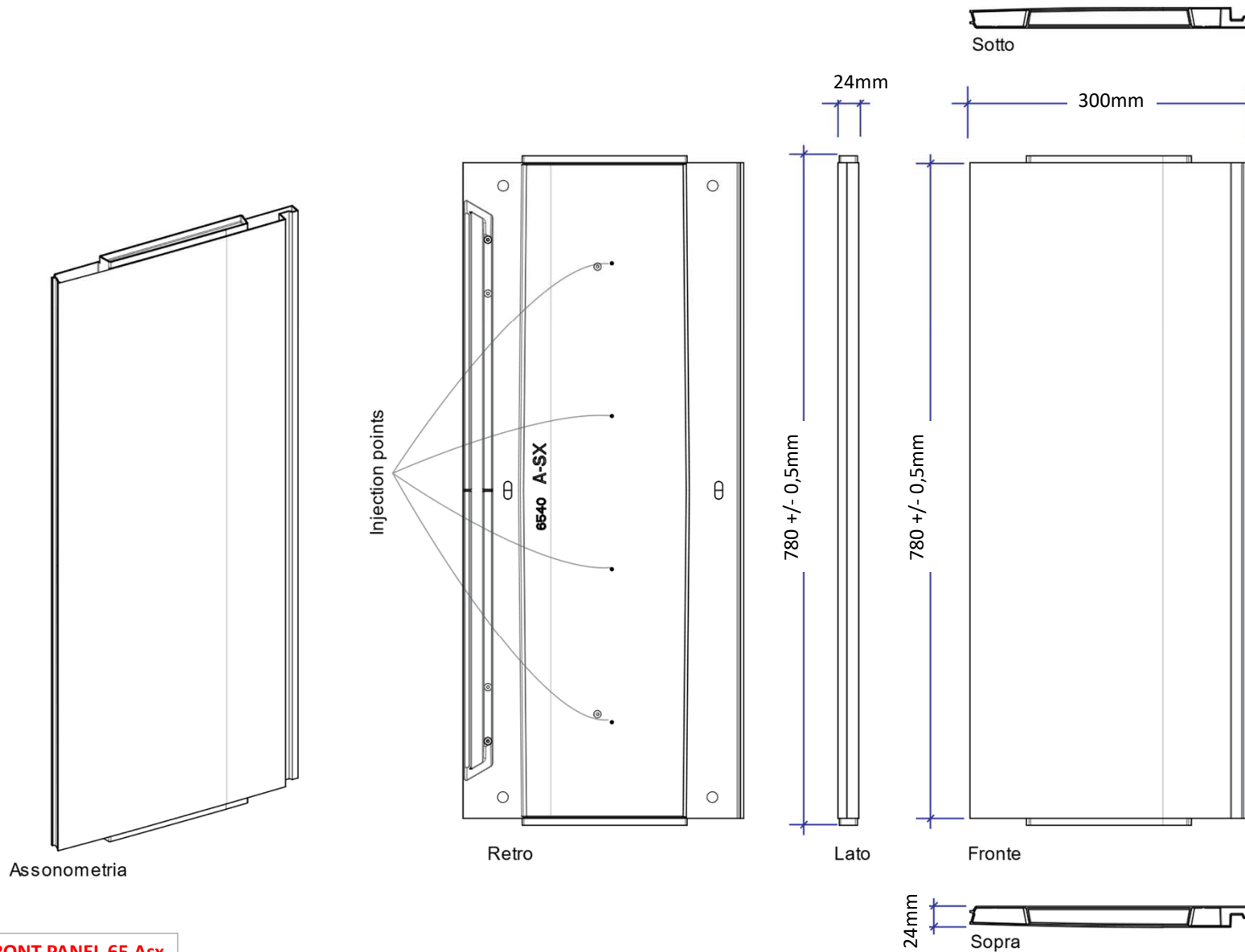

Asx

Kit FRONT PANEL 65 Asx

- Material shrinkage coefficient (PP): 1.8%
- Tolerance on indicated dimensions: +/- 0,5 mm
- Texture: Same of other molds of the same product family
- Color: black PP (4000022)

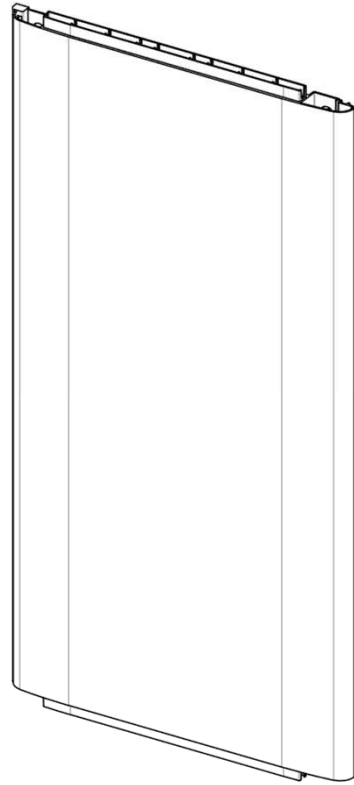

Assonometria

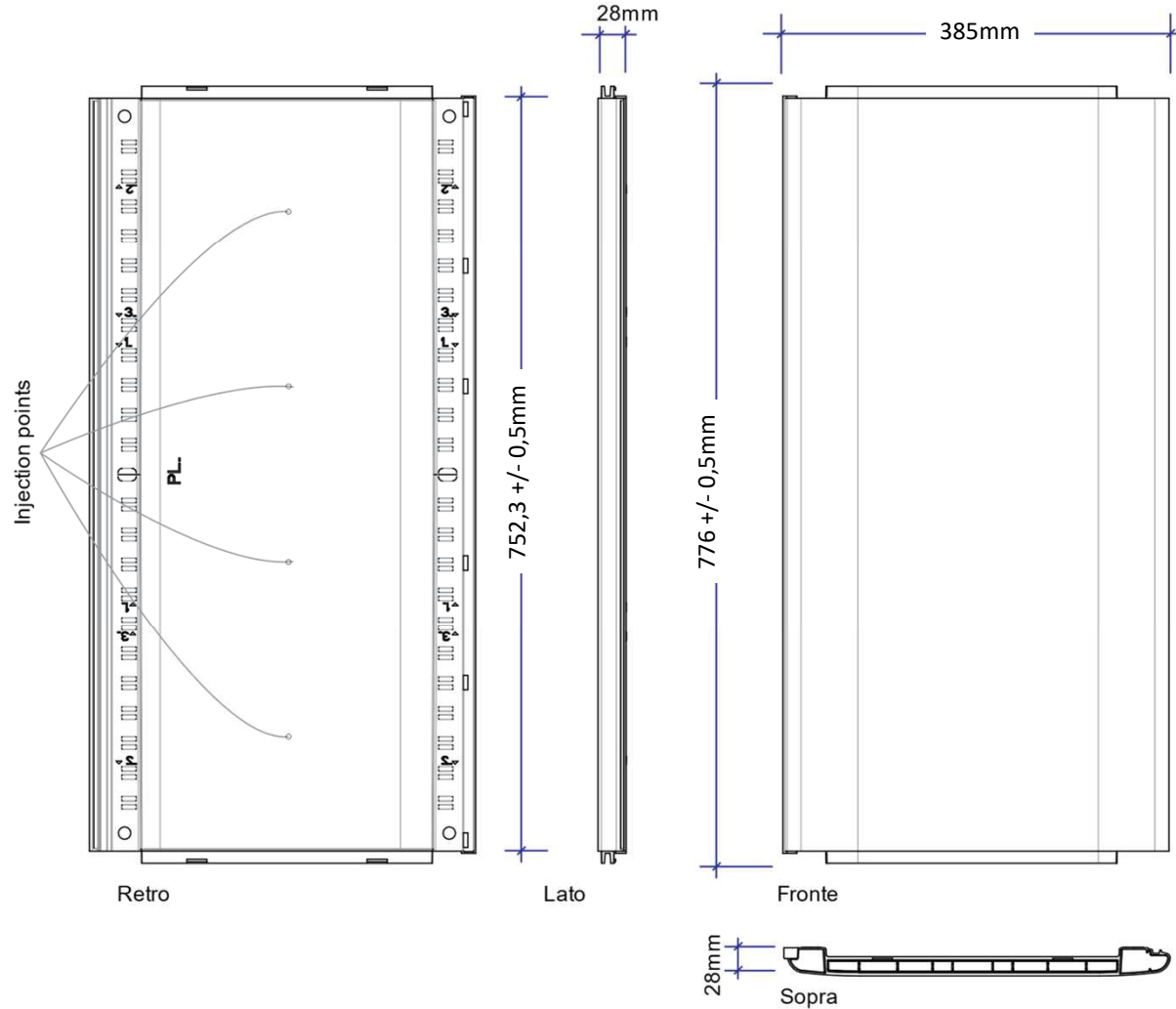

PL

SIDE PANEL 65

- Material shrinkage coefficient (PP): 1.8%
- Tolerance on indicated dimensions: +/- 0,5 mm
- Texture: Same of other molds of the same product family
- Color: black PP (4000022)

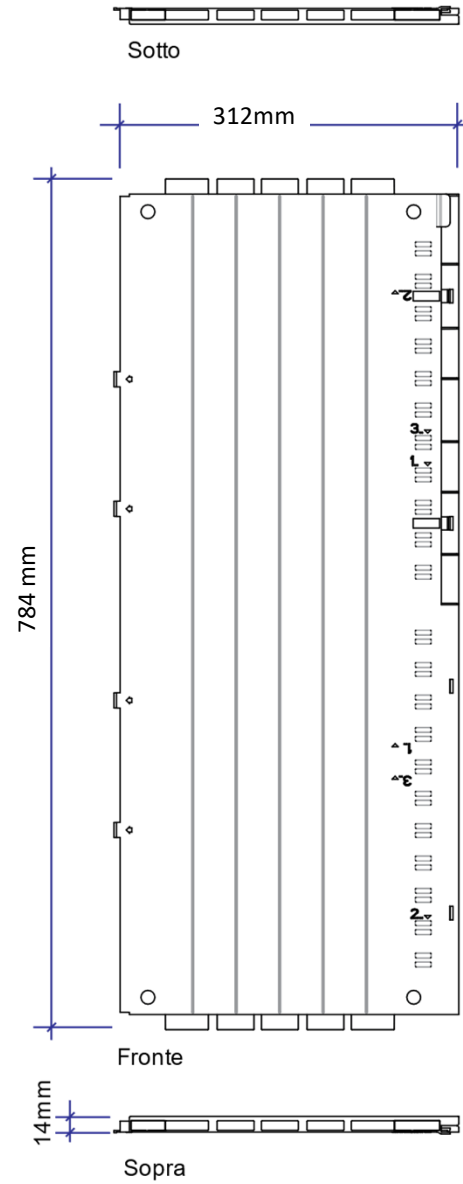
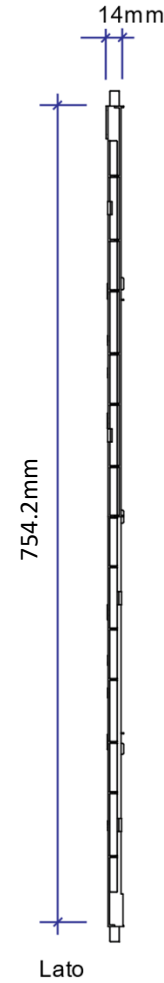
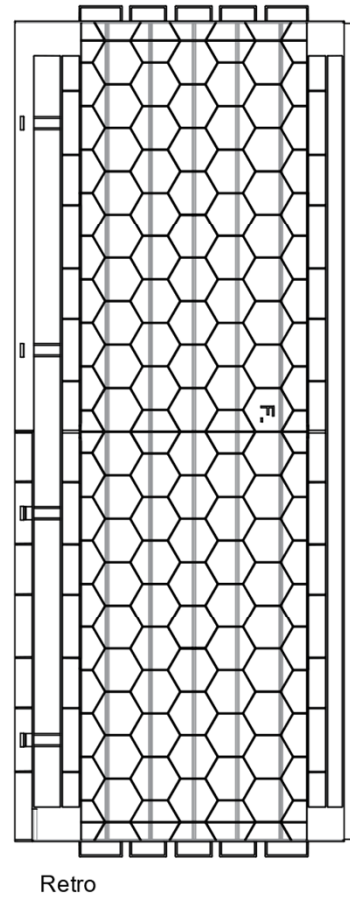
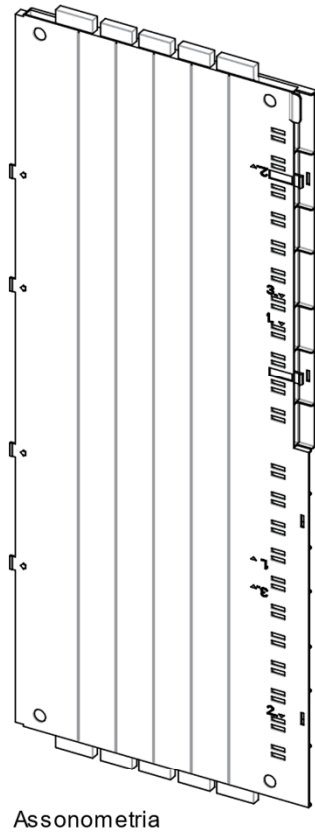

F

BACK PANEL 65

- Material shrinkage coefficient (PP): 1.8%
- Texture: Same of other molds of the same product family
- Color: grey PP (4000024)

NEW KIT END CAPS HINGES 65 (ST1+ST2+ST3+ST4)

ST3sx

(#3)Top hinge SX

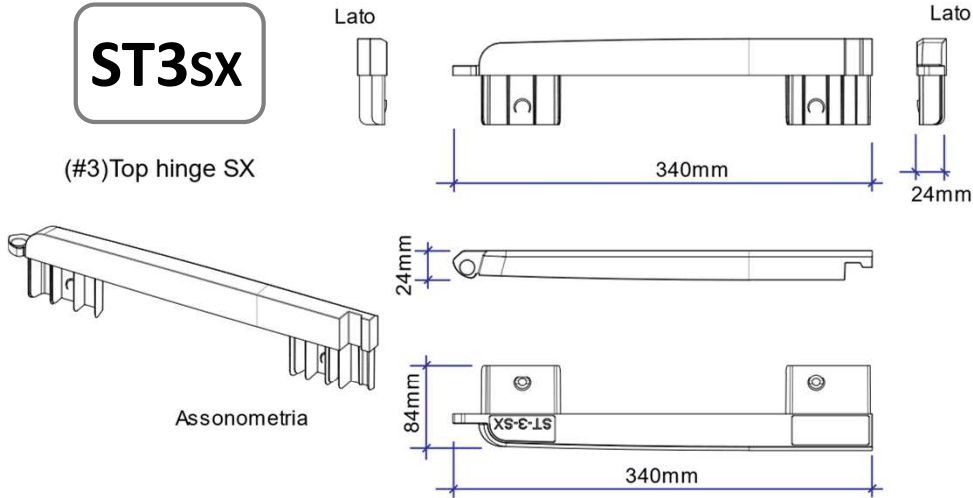

ST2DX

(#2)Top hinge DX

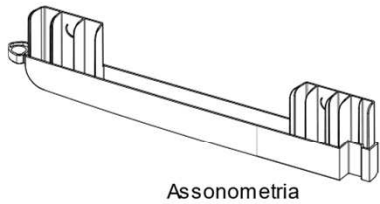
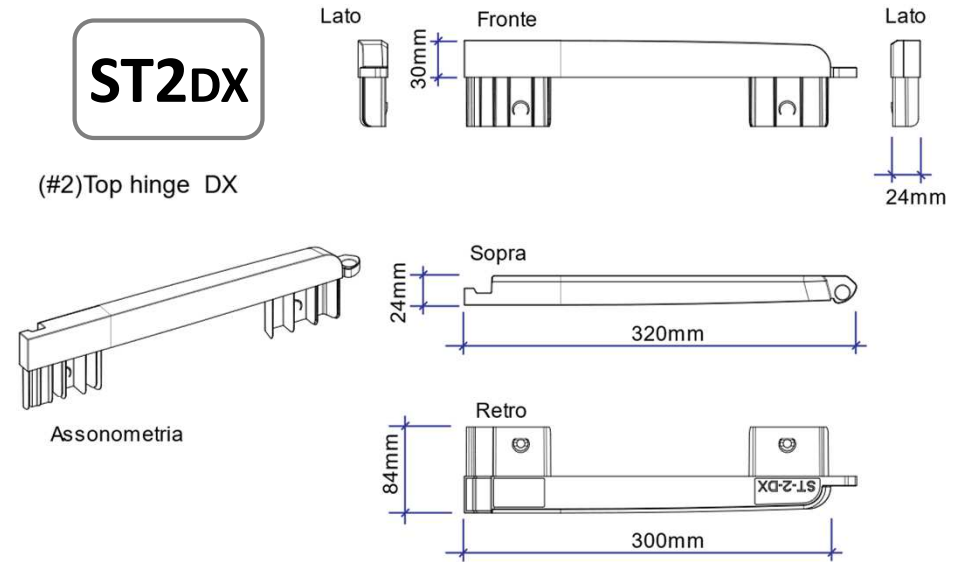

Assonometria

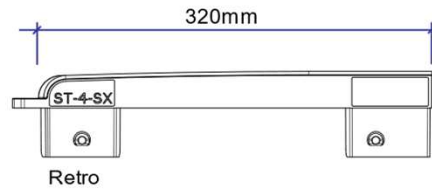

Retro



Sopra

(#4)Bottom hinge SX

ST4sx

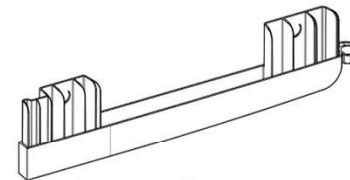
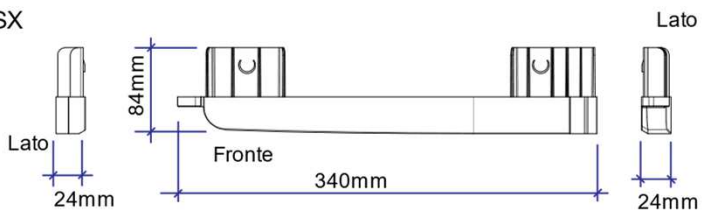

Assonometria



Retro

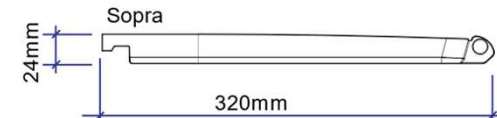

Sopra

(#1)Bottom hinge DX

ST1DX

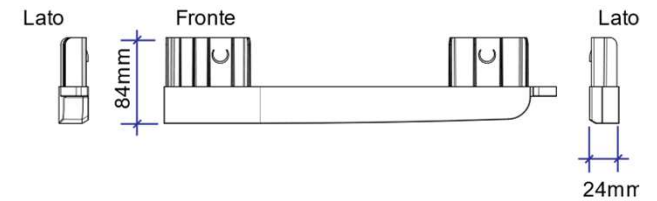

- Material shrinkage coefficient (PP): 1.8%
- Texture: Same of other molds of the same product family
- Color: black PP (4000022)

KIT TOP-BOTTOM INSERTS (ZTsx+ZTdx)

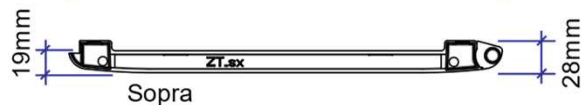
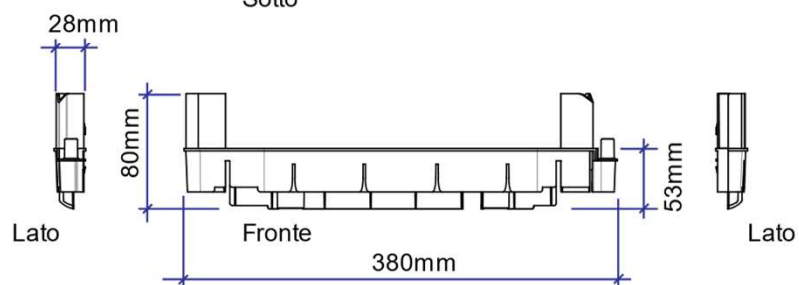
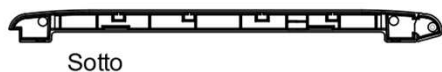
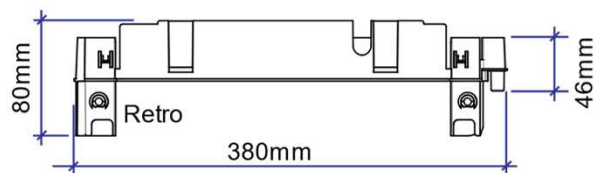
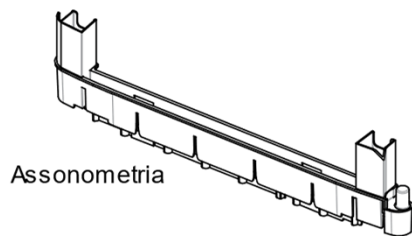

ZTsx

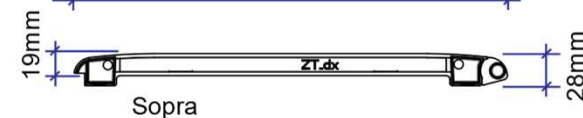
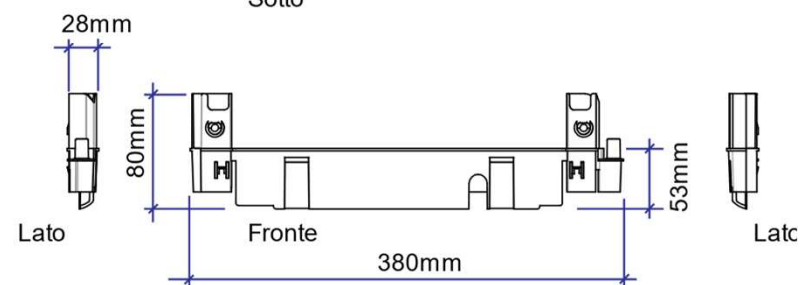
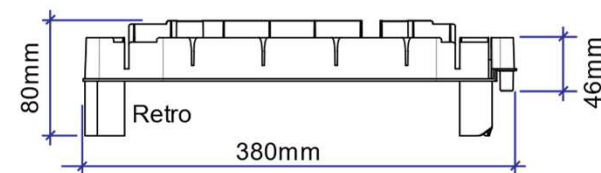
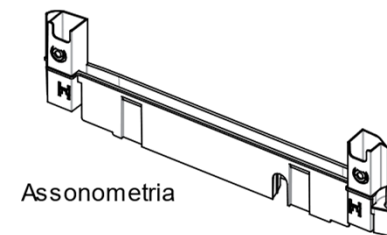

ZTDX

- Material shrinkage coefficient (PP): 1.8%
- Tolerance on indicated dimensions: +/- 0,5 mm
- Texture: Same of other molds of the same product family
- Color: black PP (4000022)

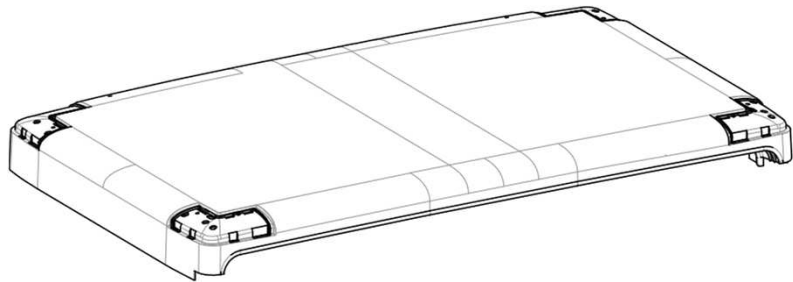

Assonometria TOP

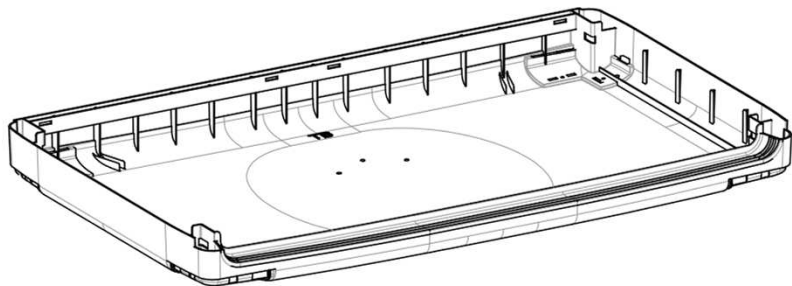

Assonometria BOTTOM

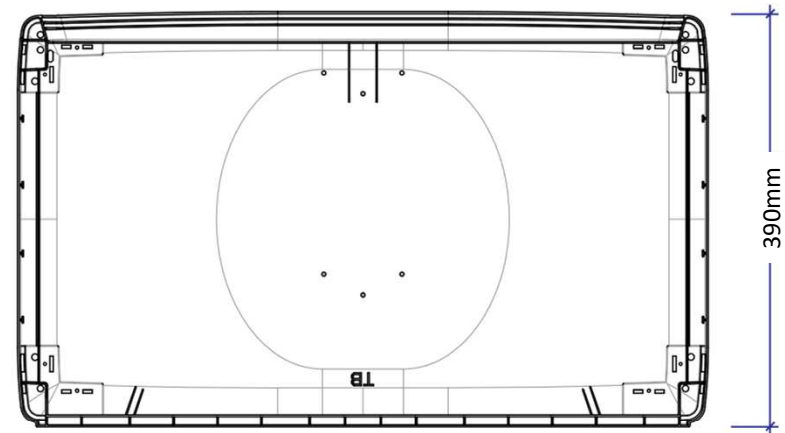

Sotto

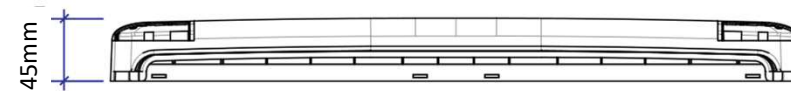

Fronte

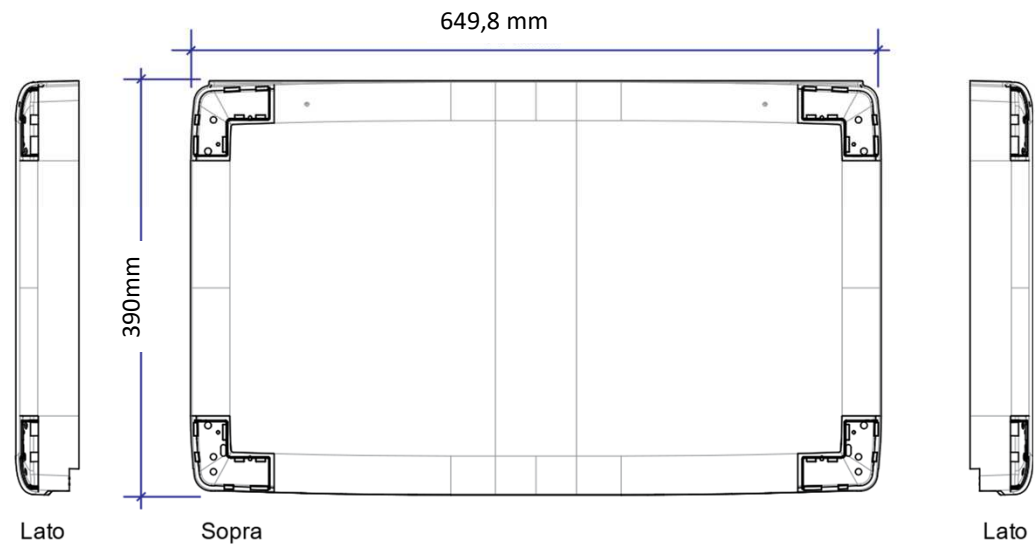

Lato

Sopra

Lato

TB

TOP/BOTTOM 65 (TB)

- Material shrinkage coefficient (PP): 1.8%
- Texture: Same of other molds of the same product family
- Color: black PP (4000022)

TOP/BOTTOM 65 (TB)KIT TOP END CAPS COOL CABINETS (G1+G2)



Assonometria

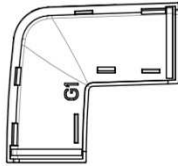

Sotto

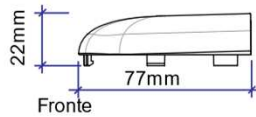

Fronte

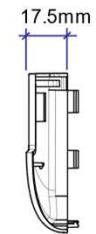

Lato

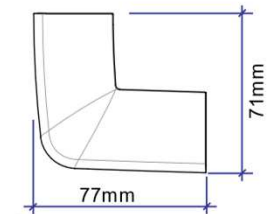

Sopra



Lato

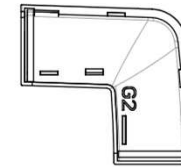

Sotto

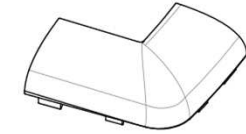

Assonometria

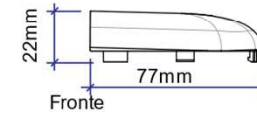

Fronte

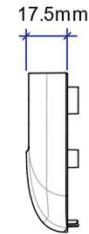

Lato

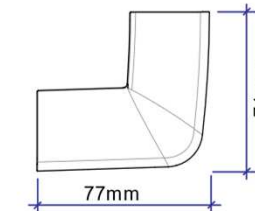

Sopra



Lato

G1

G2

- Material shrinkage coefficient (PP): 1.8%
- Texture: Same of other molds of the same product family
- Color: black PP (4000022)

**KIT FEET COOL CABINETS
(AC+AL+AR+R)**



Assonometria



Sotto
80mm 28mm



Lato

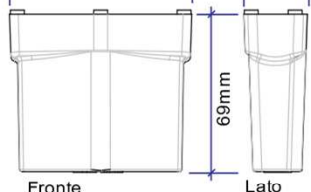

Fronte

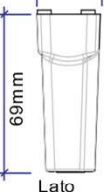

Lato



Sopra

AC

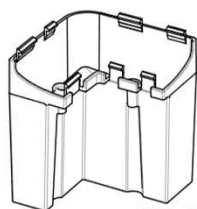

Assonometria

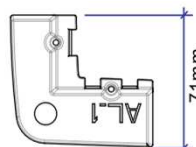

Sotto
78mm 71mm

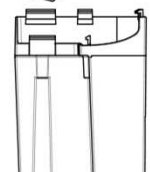

Lato

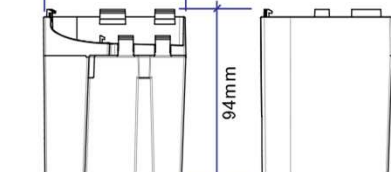

Fronte



Lato

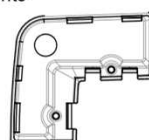

Sopra

AL1

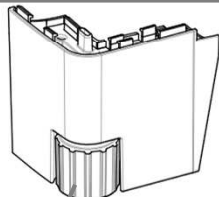

Assonometria

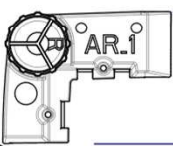

Sotto
92mm 71mm 71mm

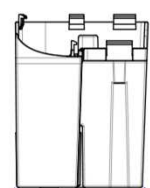

Lato

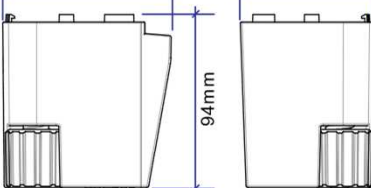

Fronte

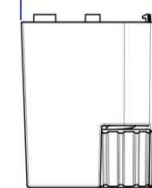

Lato

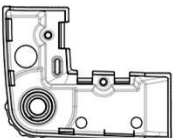

Sopra

AR1

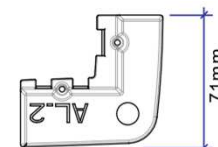

Sotto
78mm 71mm

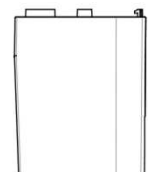

Lato

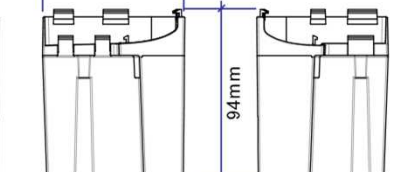

Fronte

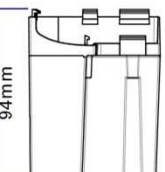

Lato

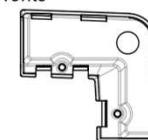

Sopra

AL2

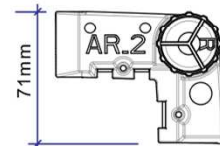

Sotto
71mm 92mm 71mm

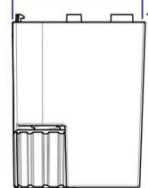

Lato

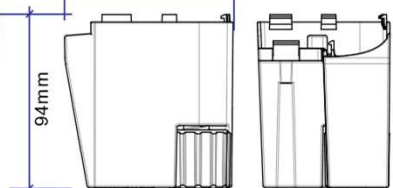

Fronte

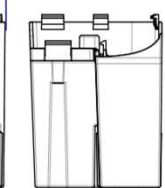

Lato

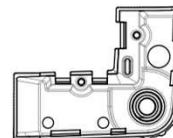

Sopra

AR2

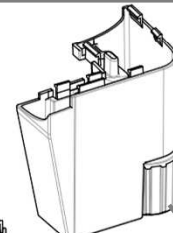

Assonometria

R

- Material shrinkage coefficient (PP): 1.8%
- Texture: Same of other molds of the same product family
- Color: grey PP (4000024)

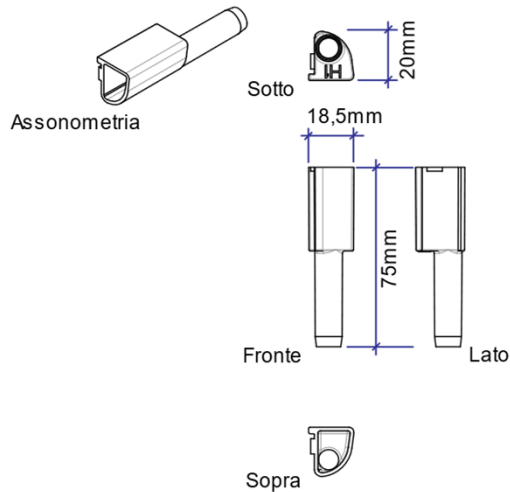

H1

KIT HINGES (H1+H2)

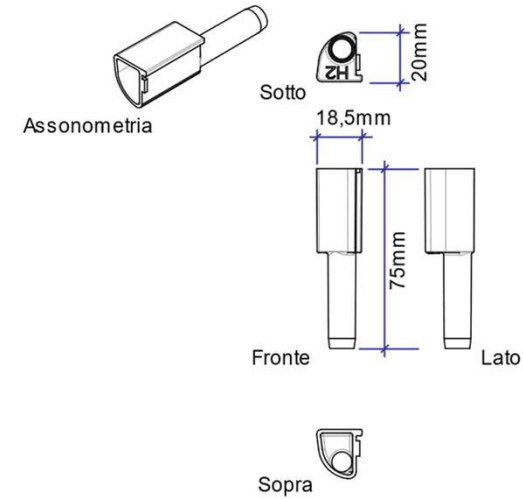

H2

- Material shrinkage coefficient (PP): 1.8%
- Texture: Same of other molds of the same product family
- Color: black PP (4000022)

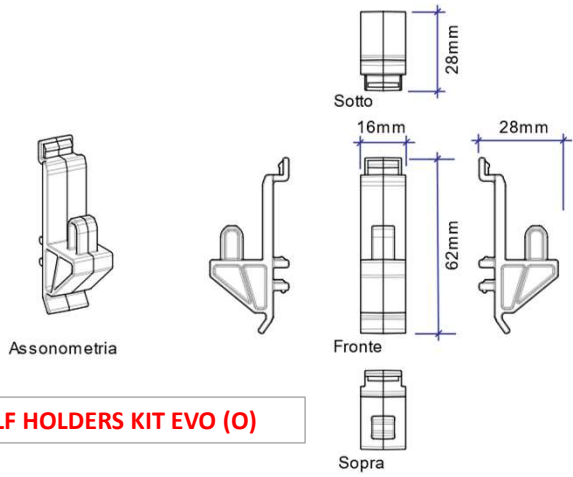

O

INNER SHELF HOLDERS KIT EVO (O)

- Material shrinkage coefficient (PP): 1.8%
- Texture: Same of other molds of the same product family
- Color: black PP (4000022)

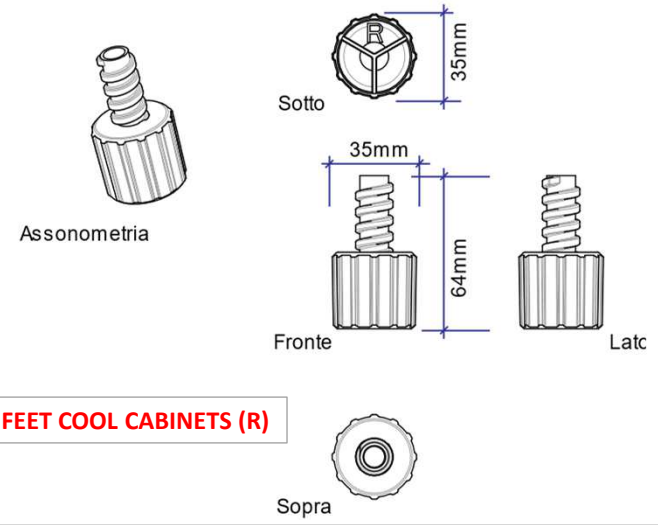

R

KIT FEET COOL CABINETS (R)

- Material shrinkage coefficient (PP): 1.8%
- Texture: Same of other molds of the same product family
- Color: black PP (4000022)

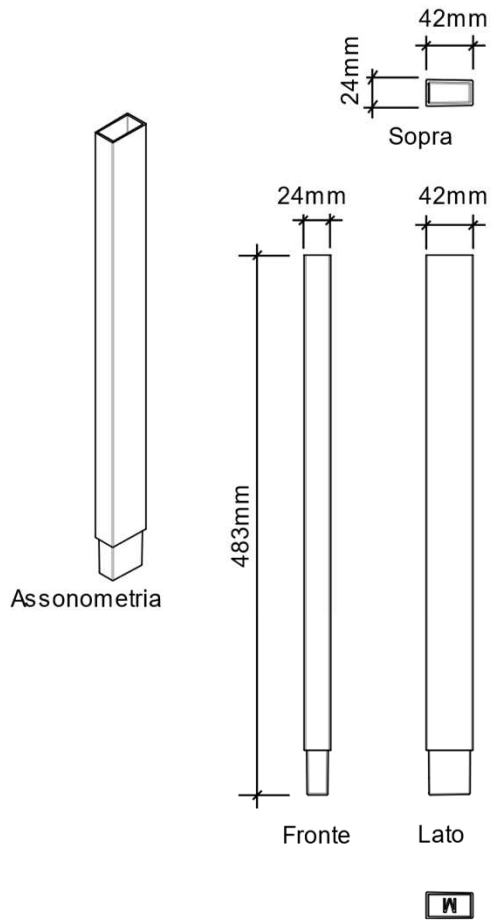

M

SQUARE POLE FOR INNER SHELF COOL CABINET (M)

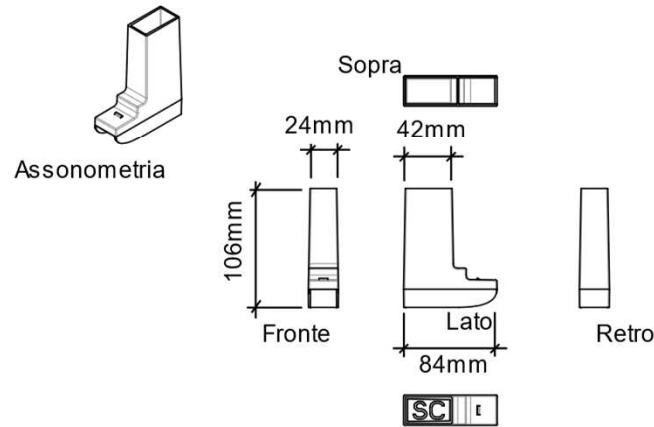

SC

SQUARE POLE BASE (SC)

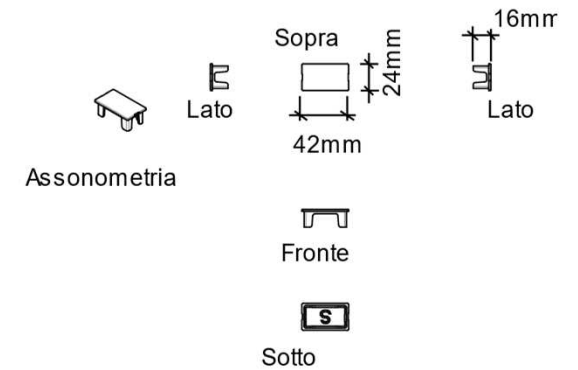

S

TOP CAP INNER SHELF (S)

- Material shrinkage coefficient (PP): 1.8%
- Tolerance on indicated dimensions: +/- 0,5 mm
- Texture: Same of other molds of the same product family
- Color: black PP (4000022)

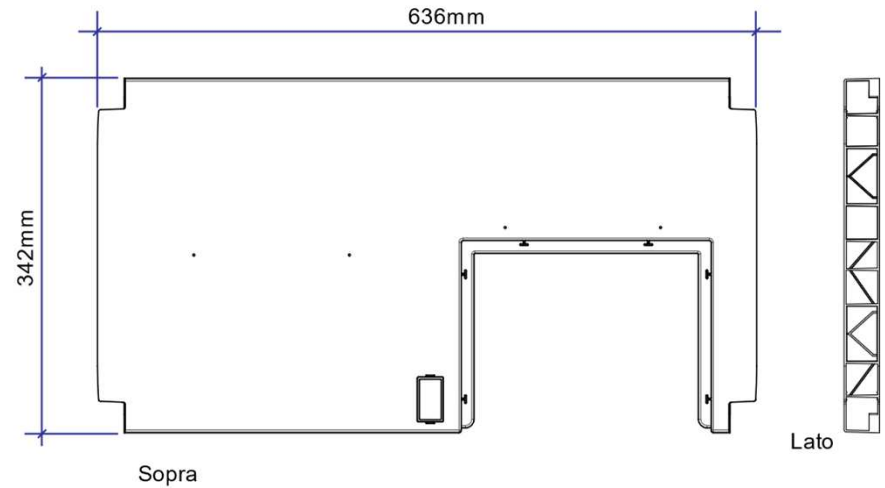
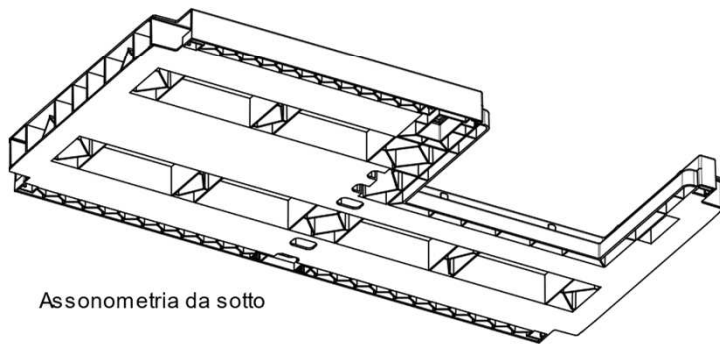
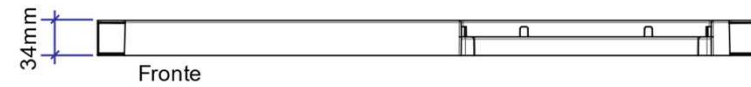
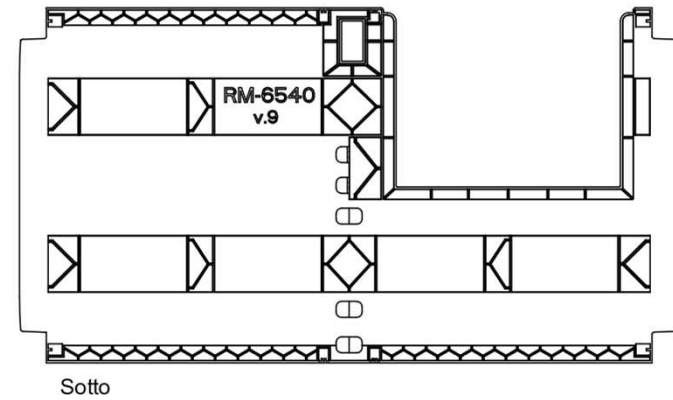
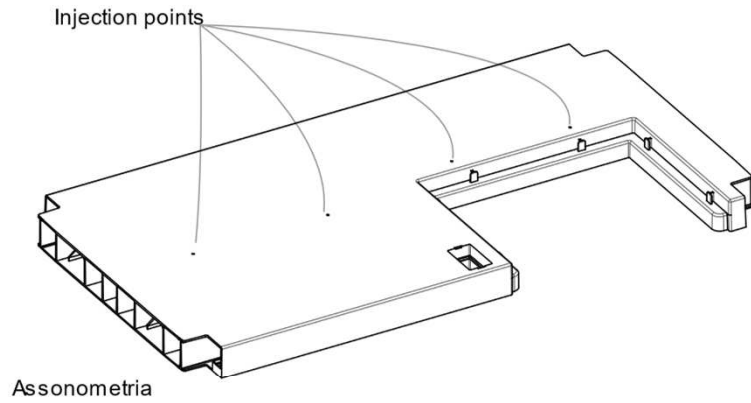

RM

NEW CONVERTIBLE INNER SHELF 65
(RM)

- Material shrinkage coefficient (PP): 1.8%
- Texture: Same of other molds of the same product family
- Color: black PP (4000022)

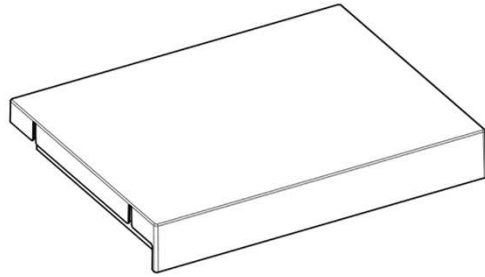

Assonometria

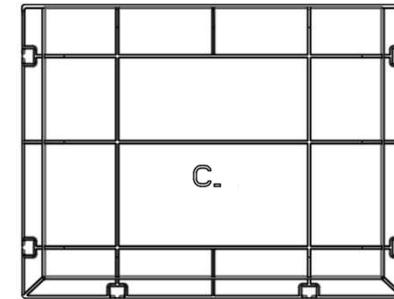

Sotto

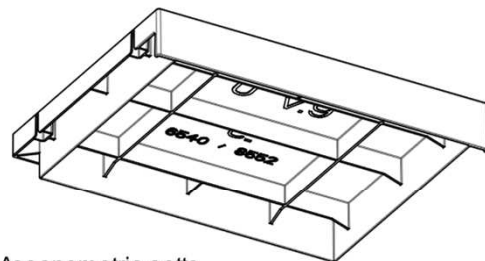

Assonometria sotto

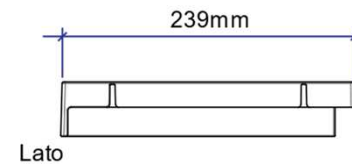

Lato

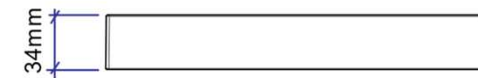

Fronte

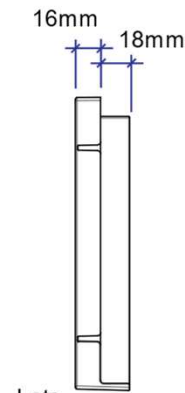

Lato

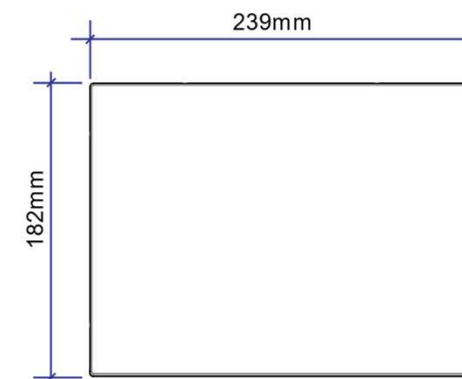

Sopra

C

NEW INNER SHELF INSERT (C)

- Material shrinkage coefficient (PP): 1.8%
- Texture: Same of other molds of the same product family
- Color: black PP (4000022)
- Color: grey PP (4000024)

NEW HANDLE KIT EVO (K1+K2+K)

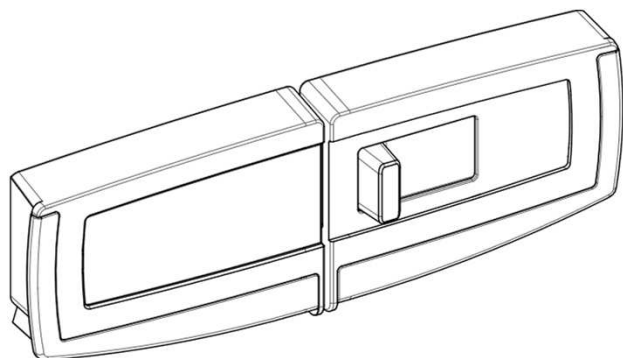

Assonometria

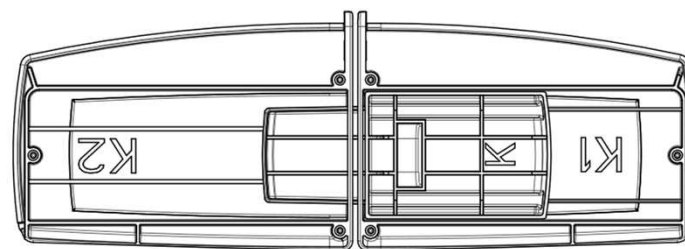

Retro

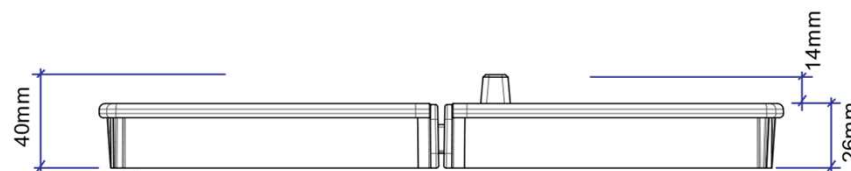

Sopra

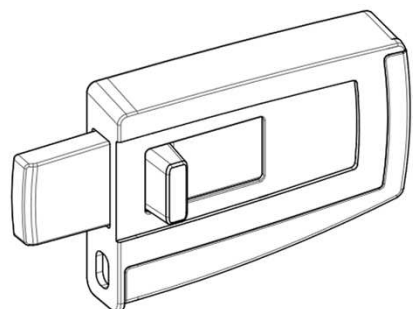

Assonometria

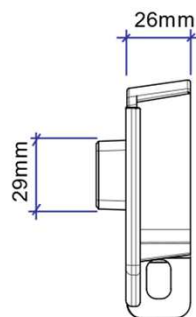

Lato

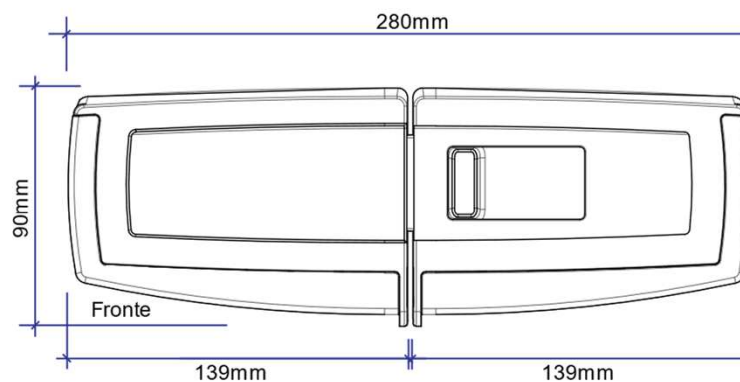

Fronte

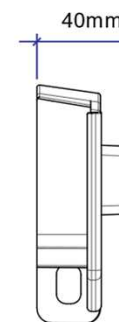

Lato

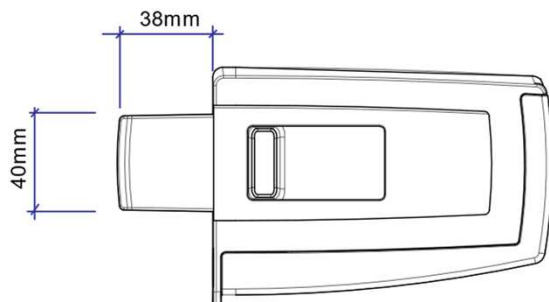

Fronte

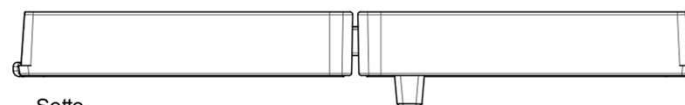

Sotto

K1

K2

K