

# Technical drawings with tolerances

L3 range

**HIGH RESIN CABINET 65 CM**

**MATRIX ID - 2022R14P02-0015**

**Gtin 13: 3276007359237**



HIGH RESIN CABINET 65 CM  
2022R14P02-0015

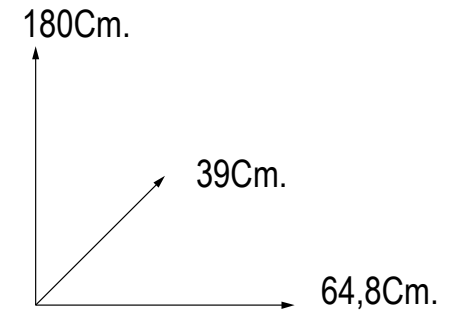

Tolerance on overall dimensions: +/- 10 mm

Overall gross weight (including packaging) : 17.000 gr with tolerance of +/- 5%

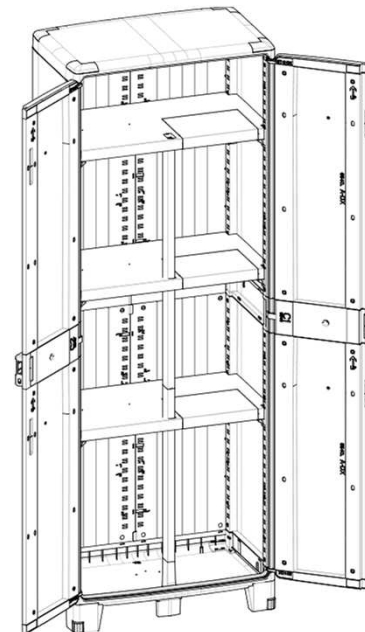
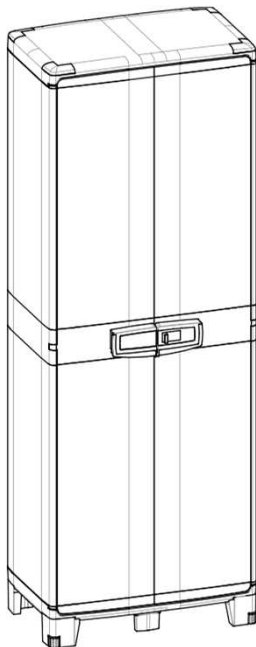

# Exploded View

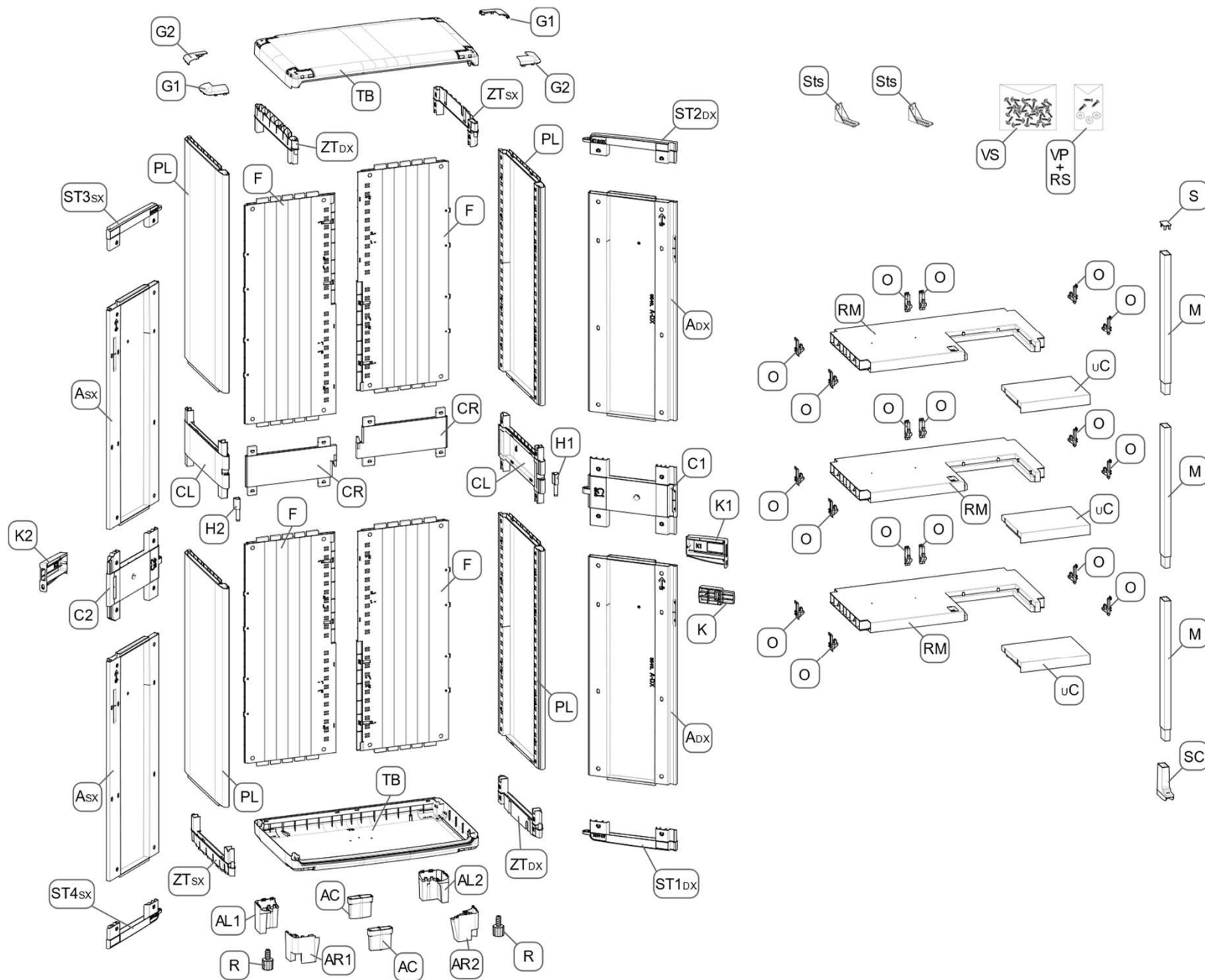

- Material shrinkage coefficient (PP): 1.8%
- Tolerance on indicated dimensions: +/- 0,5 mm
- Texture: Same of other molds of the same product family
- Color: grey PP (4000024)

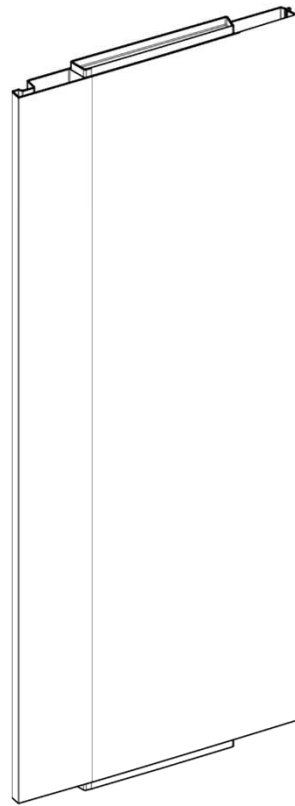

Assonometria

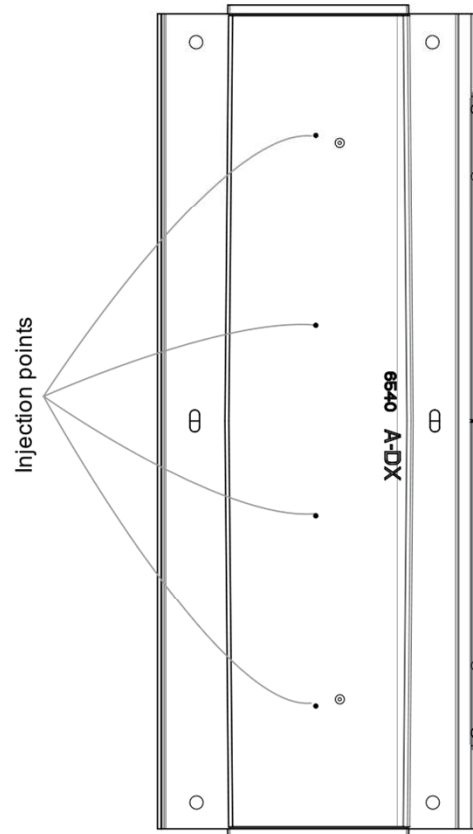

Injection points

Retro

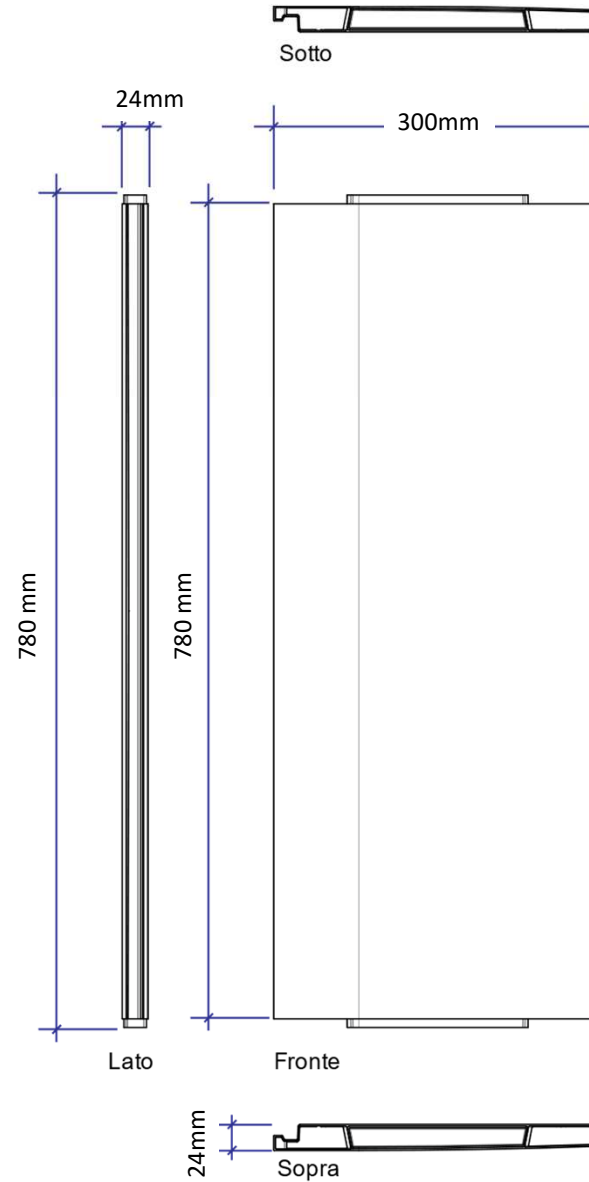

24mm

300mm

780 mm

780 mm

Lato

Fronte

24mm

Sopra

**ADX**

**KIT FRONT PANEL 65 Adx**

- Material shrinkage coefficient (PP): 1.8%
- Tolerance on indicated dimensions: +/- 0,5 mm
- Texture: Same of other molds of the same product family
- Color: grey PP (4000024)

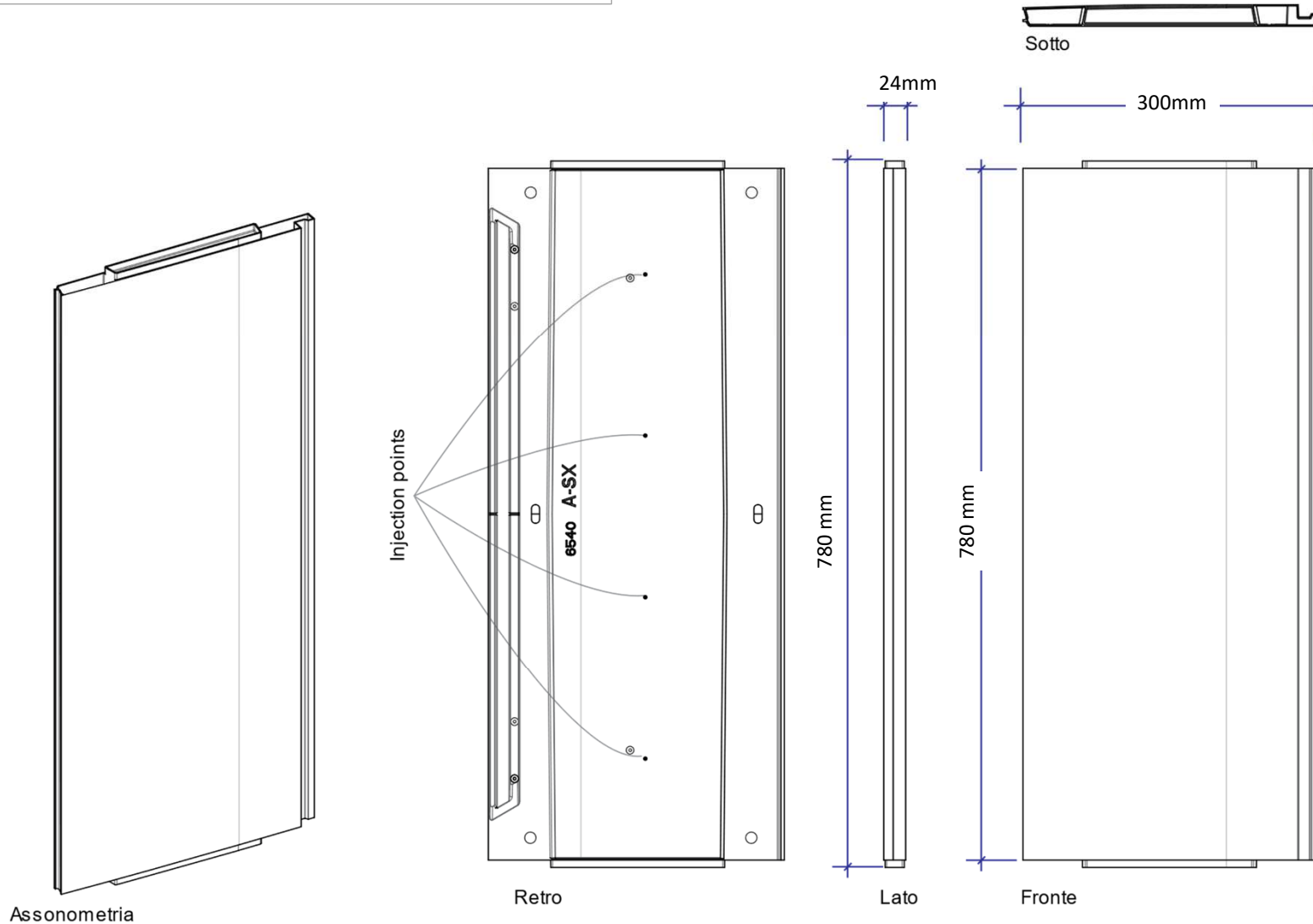

**Asx**

**Kit FRONT PANEL 65 Asx**

- Material shrinkage coefficient (PP): 1.8%
- Tolerance on indicated dimensions: +/- 0,5 mm
- Texture: Same of other molds of the same product family
- Color: black PP (4000022)

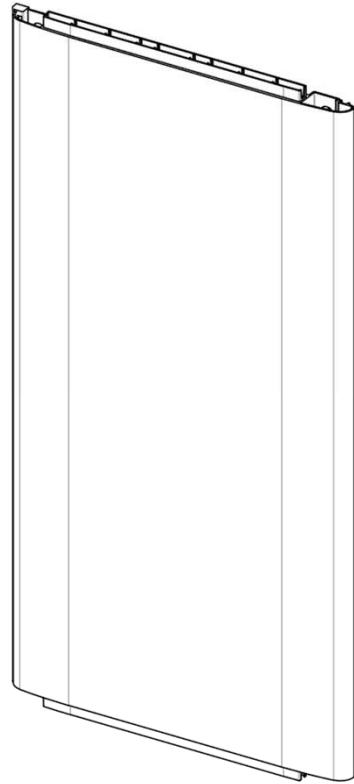

Assonometria

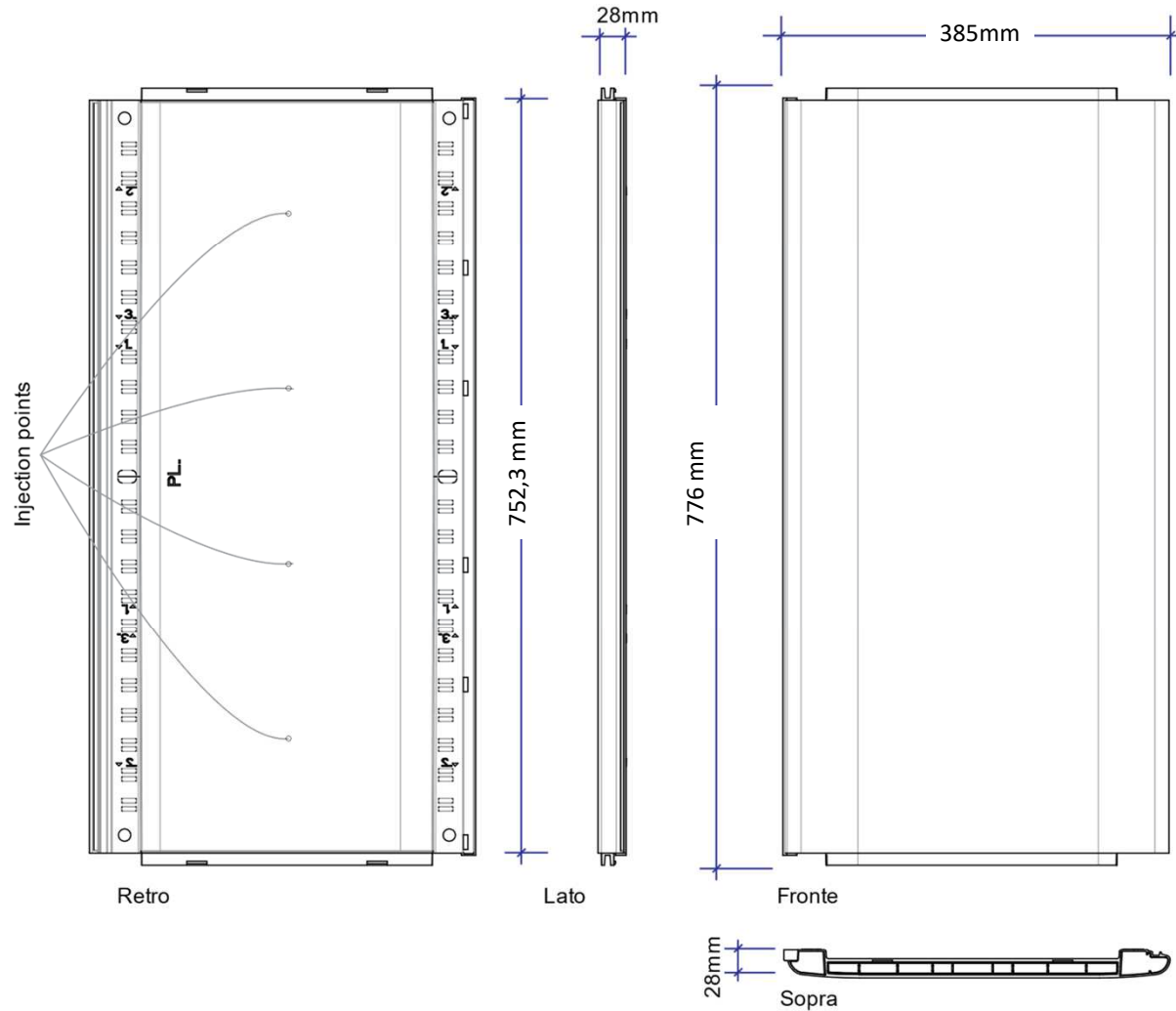

**PL**

**SIDE PANEL 65**

- Material shrinkage coefficient (PP): 1.8%
- Tolerance on indicated dimensions: +/- 0,5 mm
- Texture: Same of other molds of the same product family
- Color: black PP (400022)

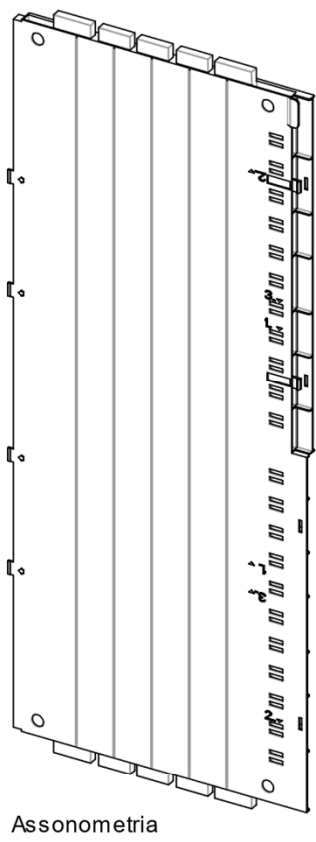

Assonometria

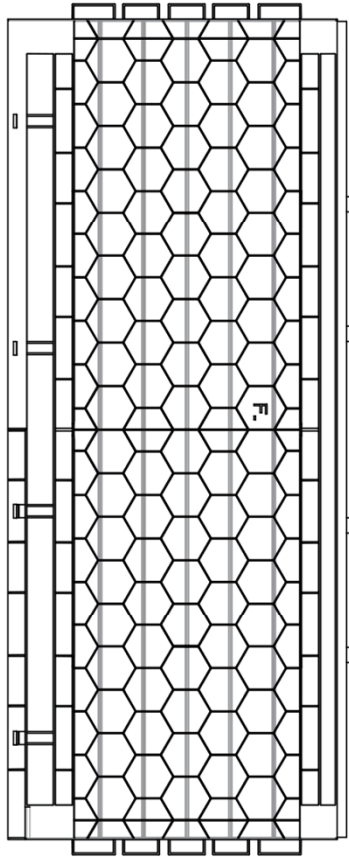

Retro

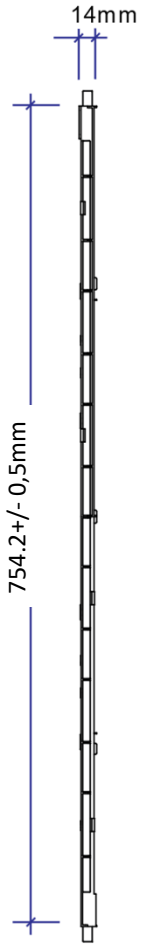

Lato

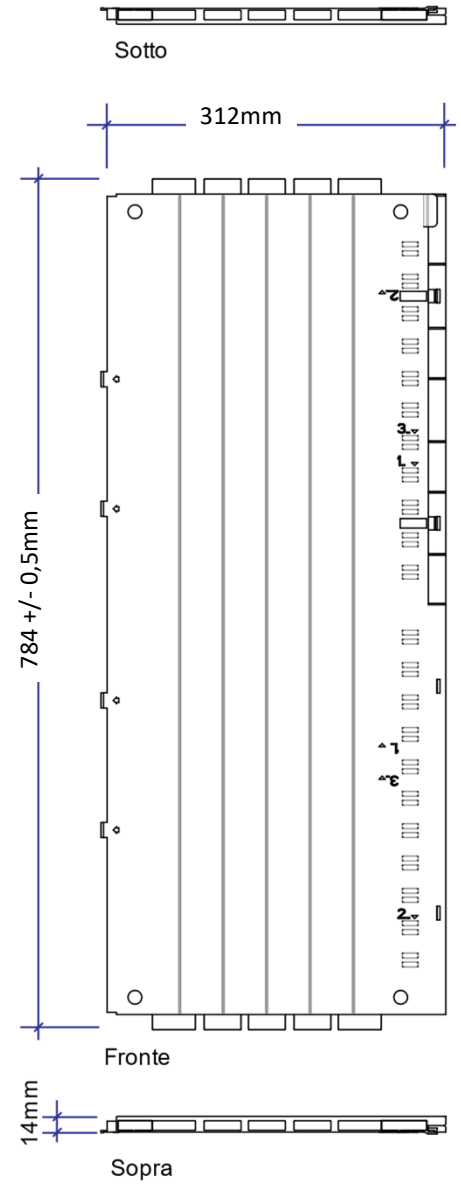

Fronte

Sopra

**F**

**BACK PANEL 65**

- Material shrinkage coefficient (PP): 1.8%
- Texture: Same of other molds of the same product family
- Color: grey PP (4000024)

**NEW KIT END CAPS HINGES 65 (ST1+ST2+ST3+ST4)**

**ST3sx**

(#3) Top hinge SX

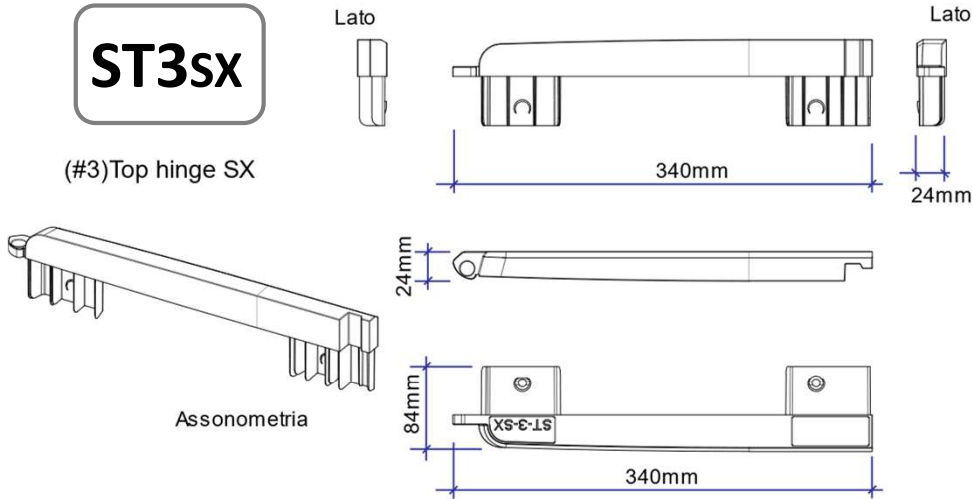

**ST2DX**

(#2) Top hinge DX

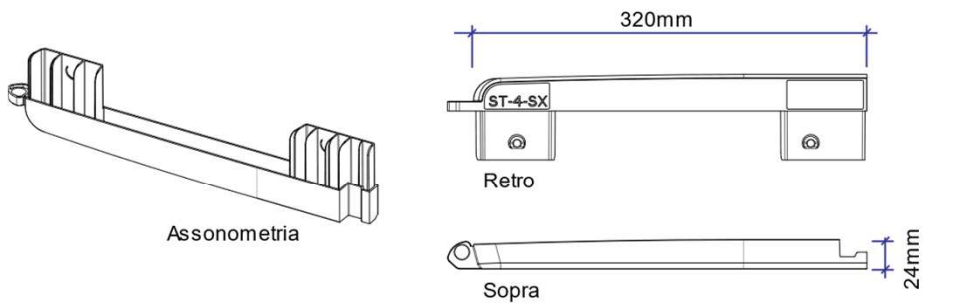
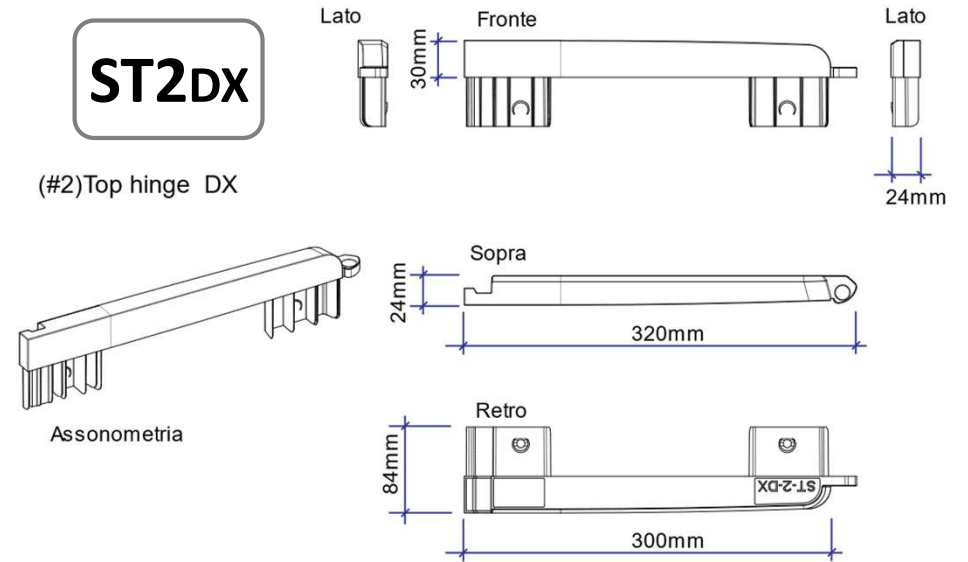

(#4) Bottom hinge SX

**ST4sx**

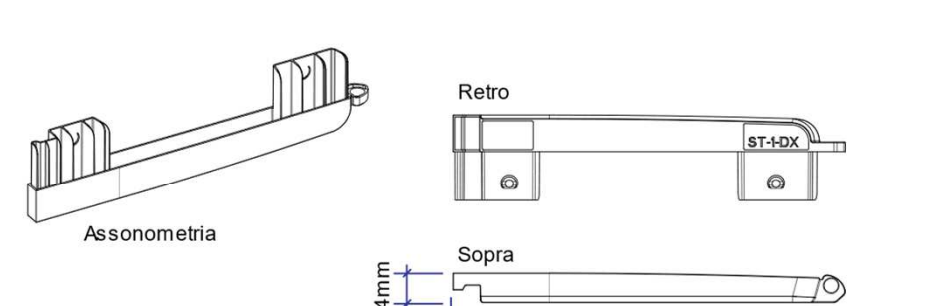
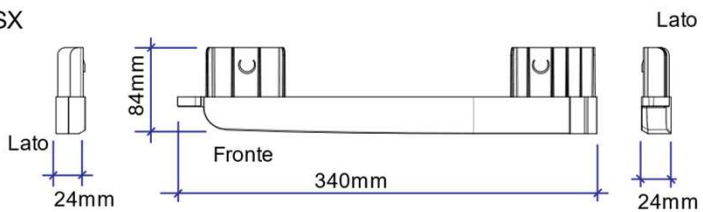

(#1) Bottom hinge DX

**ST1DX**

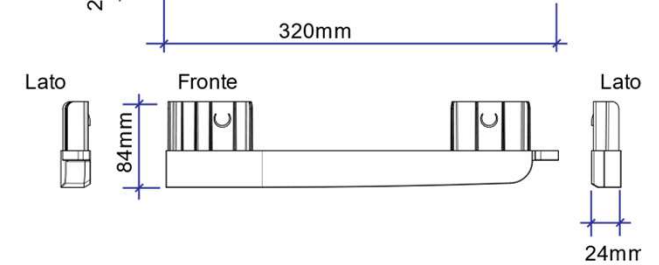



- Material shrinkage coefficient (PP): 1.8%
- Texture: Same of other molds of the same product family
- Color: grey PP (4000024)

**NEW EVO 65 BELT DOORS**

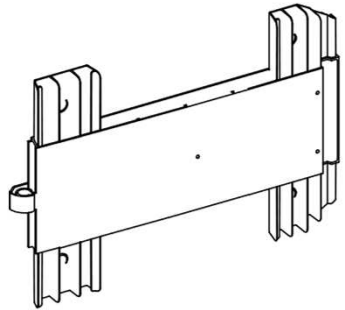

Assonometria

**C2**

Front belt SX

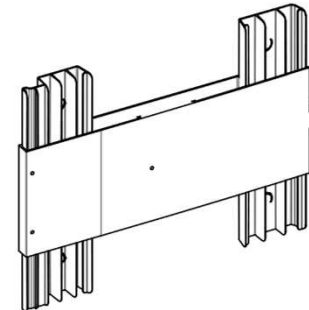
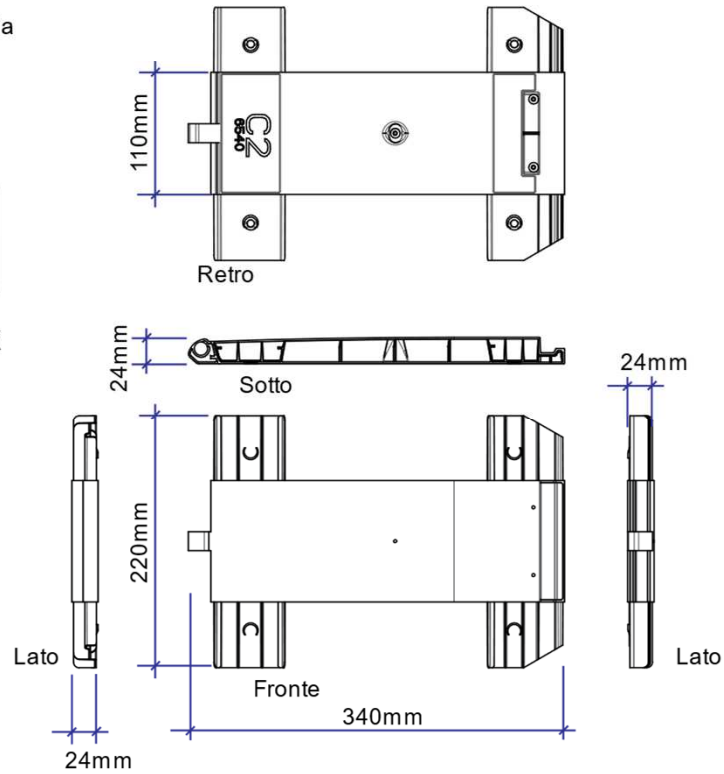

Assonometria

**C1**

Front belt DX

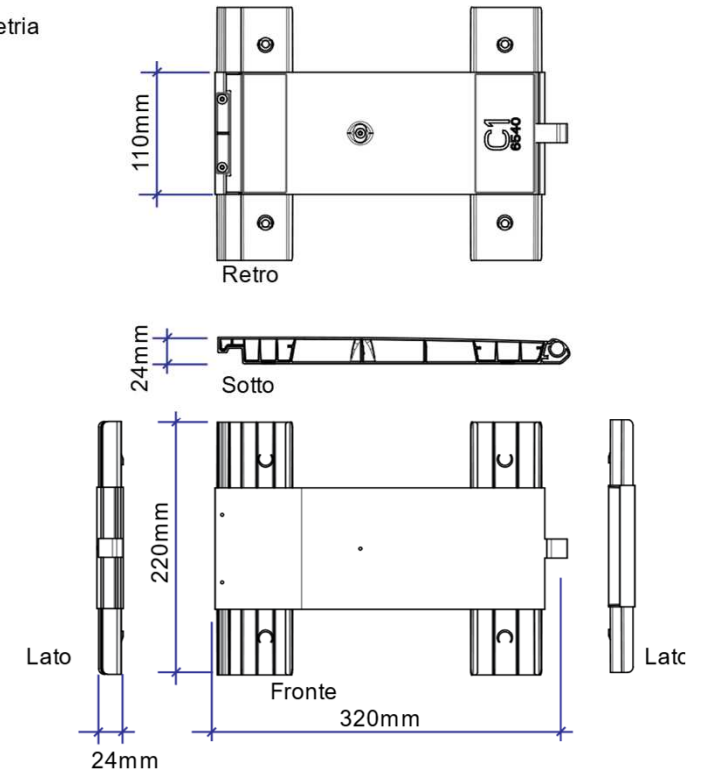

- Material shrinkage coefficient (PP): 1.8%
- Texture: Same of other molds of the same product family
- Color: black PP (4000022)

**SIDE + BACK BELT KIT 65 (CL+CR)**

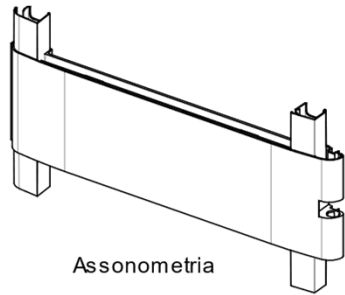

Assonometria

**CL**



Fronte



Sopra

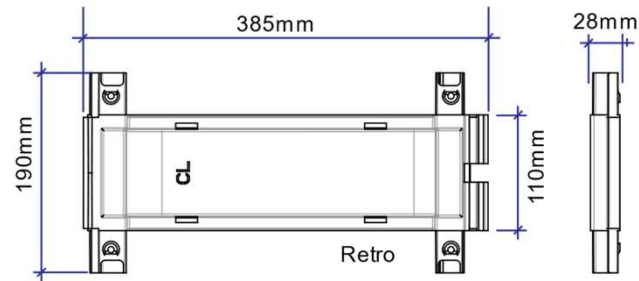

Retro



Lato

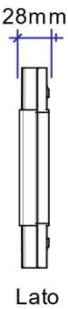

Lato



Sotto

**CR**

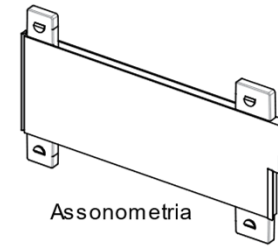

Assonometria



Fronte

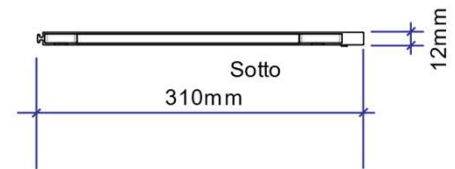

Sotto



Lato

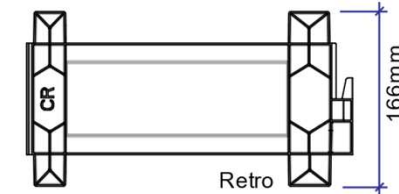

Retro



Latc



Sopra

- Material shrinkage coefficient (PP): 1.8%
- Texture: Same of other molds of the same product family
- Color: black PP (4000022)

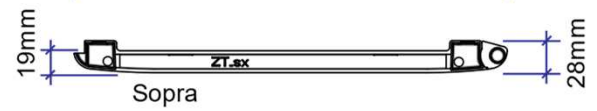
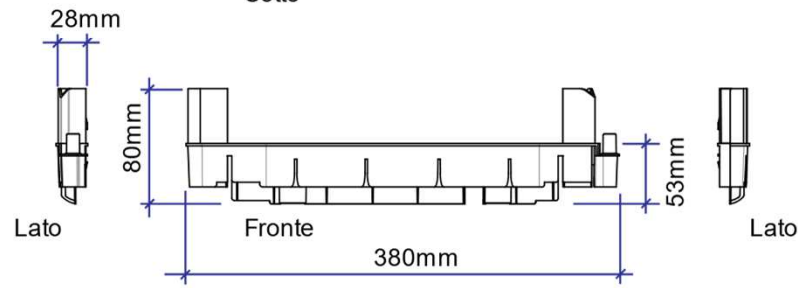
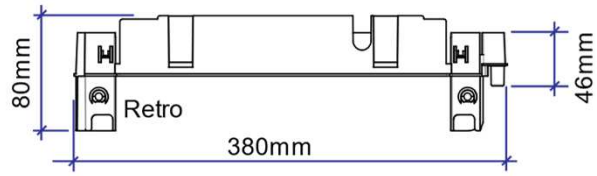
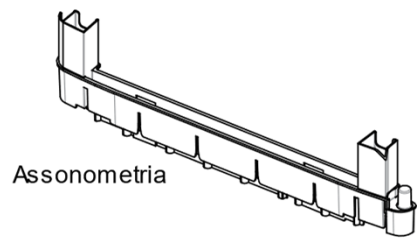

**ZTsx**

**KIT TOP-BOTTOM INSERTS (ZTsx+ZTdx)**

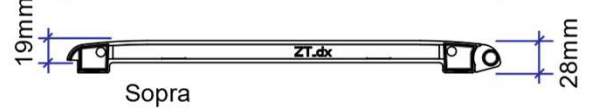
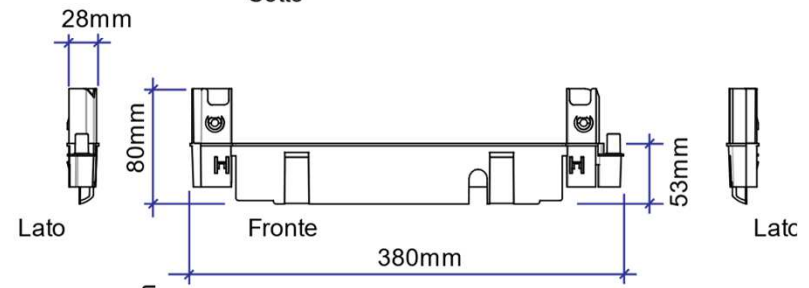
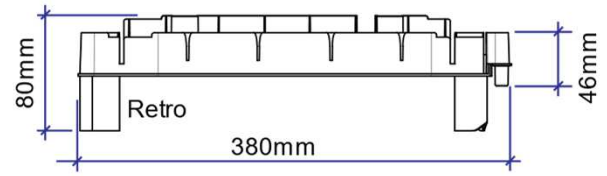
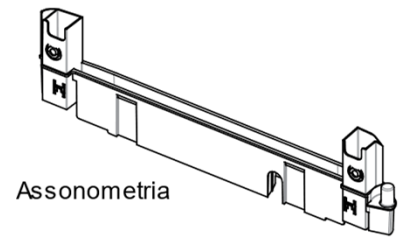

**ZTDX**

- Material shrinkage coefficient (PP): 1.8%
- Tolerance on indicated dimensions: +/- 0,5 mm
- Texture: Same of other molds of the same product family
- Color: black PP (4000022)

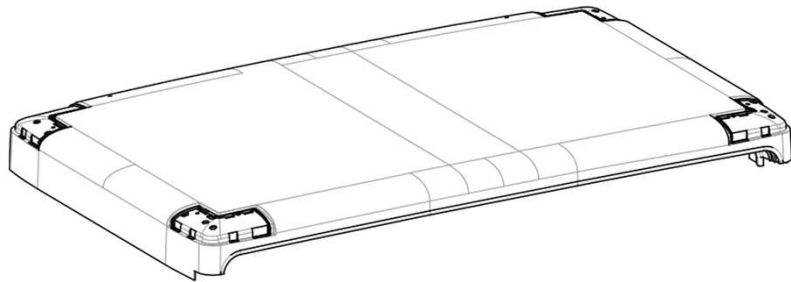

Assonometria TOP

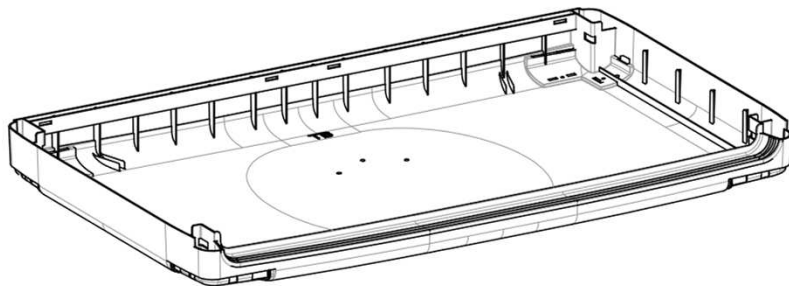

Assonometria BOTTOM

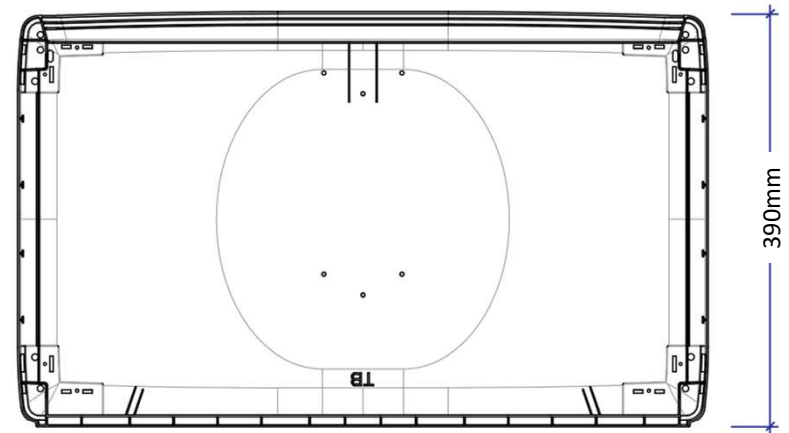

Sotto

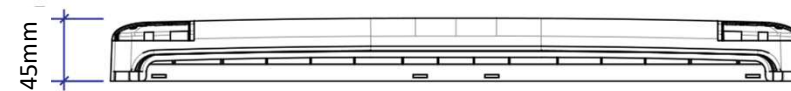

Fronte

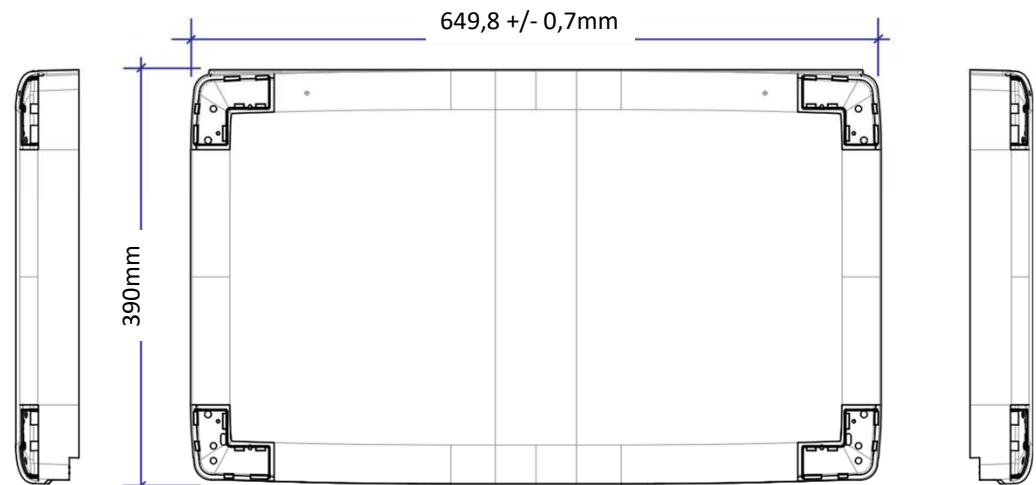

Lato

Sopra

Lato

**TB**

TOP/BOTTOM 65 (TB)

- Material shrinkage coefficient (PP): 1.8%
- Texture: Same of other molds of the same product family
- Color: black PP (4000022)

TOP/BOTTOM 65 (TB)KIT TOP END CAPS COOL CABINETS (G1+G2)



Assonometria

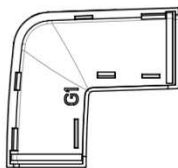

Sotto

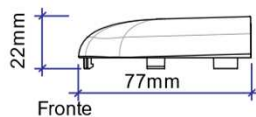

Fronte

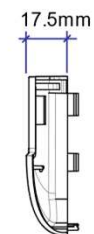

Lato

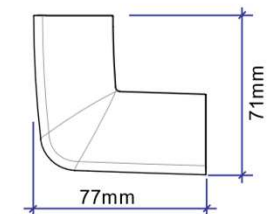

Sopra



Lato

G1

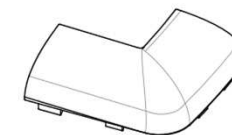

Assonometria

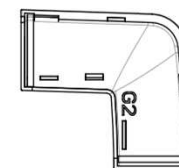

Sotto

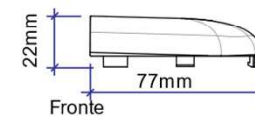

Fronte

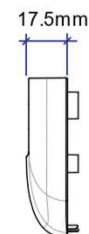

Lato

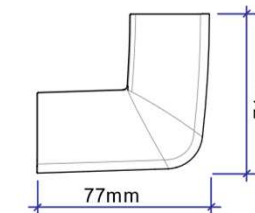

Sopra



Lato

G2

- Material shrinkage coefficient (PP): 1.8%
- Texture: Same of other molds of the same product family
- Color: black PP (4000022)

**KIT FEET COOL CABINETS (AC+AL+AR+R)**



Assonometria



Sotto  
80mm 28mm



Lato

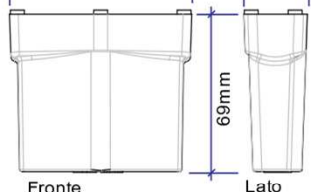

Fronte



Lato



Sopra

**AC**

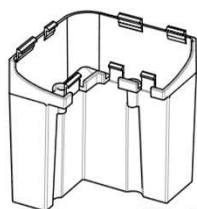

Assonometria

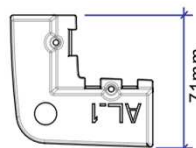

Sotto  
78mm 71mm

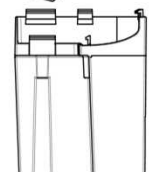

Lato

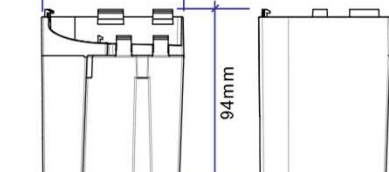

Fronte



Lato

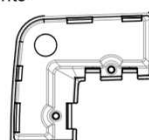

Sopra

**AL1**

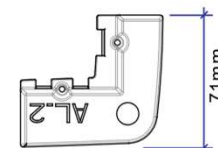

Sotto  
78mm 71mm

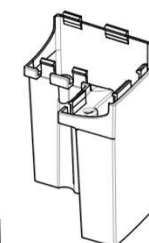

Assonometria

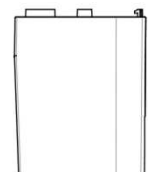

Lato

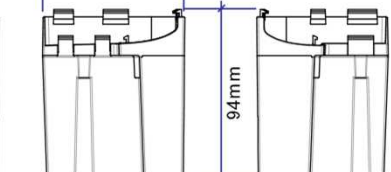

Fronte

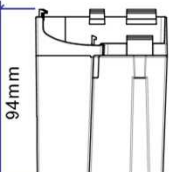

Lato

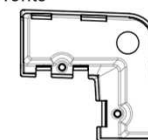

Sopra

**AL2**

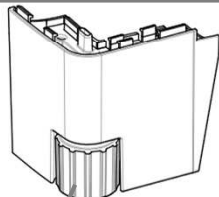

Assonometria

**R**

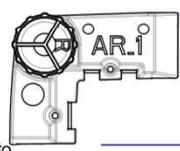

Sotto  
92mm 71mm

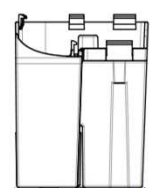

Lato

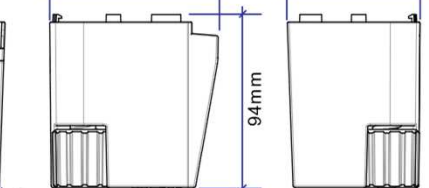

Fronte

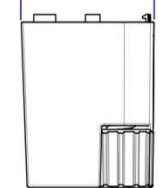

Lato

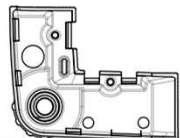

Sopra

**AR1**

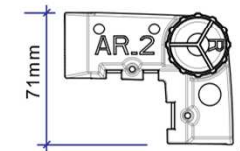

Sotto  
92mm 71mm

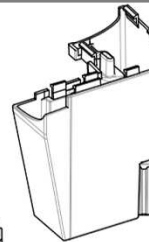

Assonometria

**R**

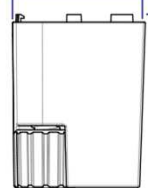

Lato

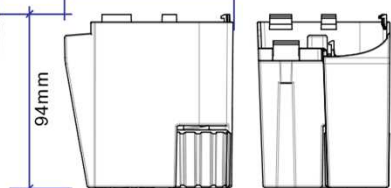

Fronte

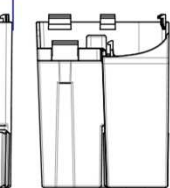

Lato

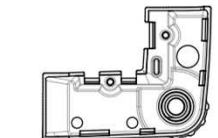

Sopra

**AR2**

- Material shrinkage coefficient (PP): 1.8%
- Texture: Same of other molds of the same product family
- Color: grey PP (4000024)

**KIT HINGES (H1+H2)**

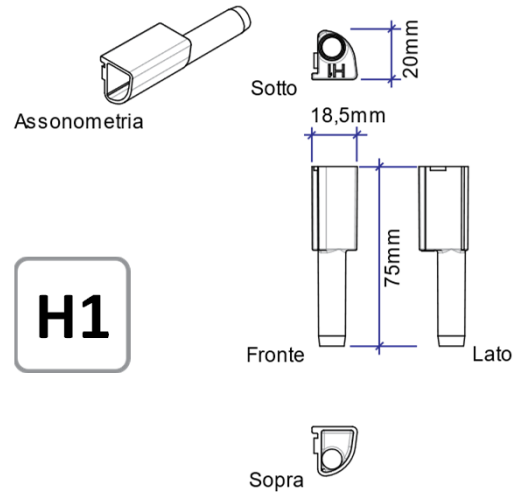

**H1**

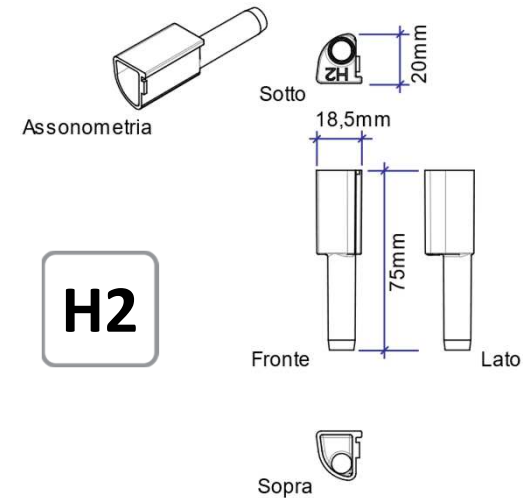

**H2**

- Material shrinkage coefficient (PP): 1.8%
- Texture: Same of other molds of the same product family
- Color: black PP (4000022)

- Material shrinkage coefficient (PP): 1.8%
- Texture: Same of other molds of the same product family
- Color: black PP (4000022)

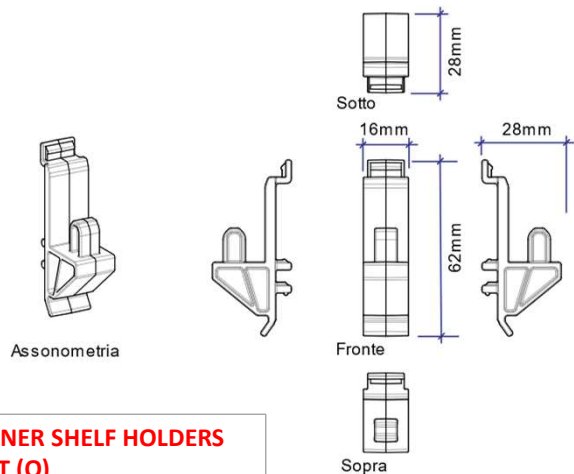

**O**

**INNER SHELF HOLDERS  
KIT (O)**

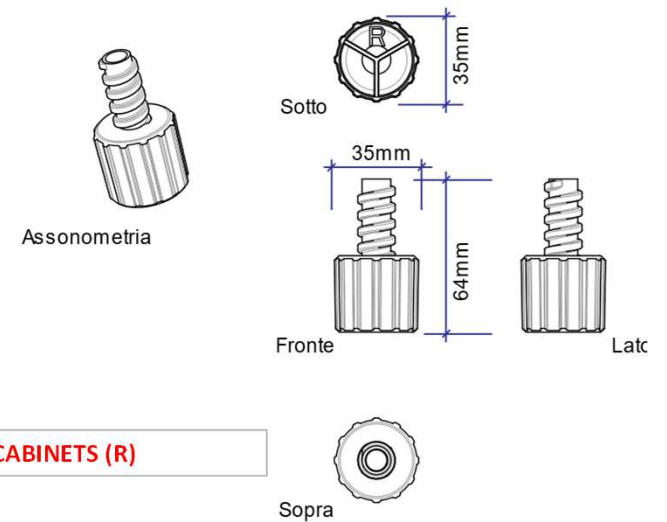

**R**

**KIT FEET COOL CABINETS (R)**

- Material shrinkage coefficient (PP): 1.8%
- Texture: Same of other molds of the same product family
- Color: black PP (4000022)

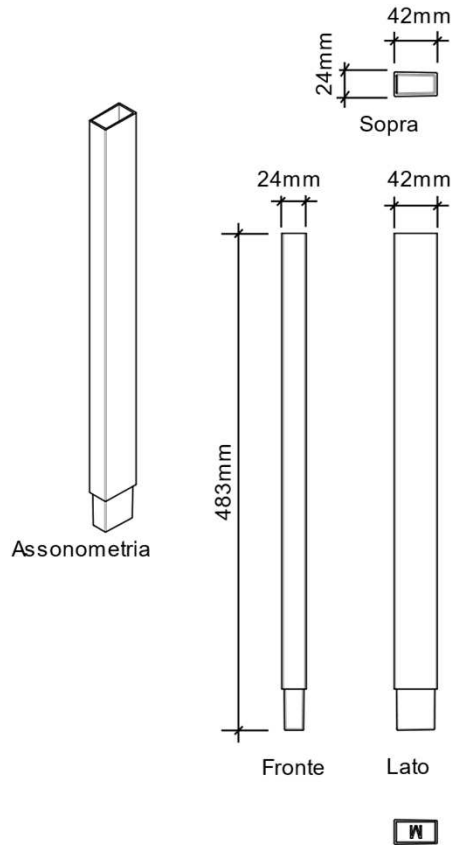

**M**

**SQUARE POLE FOR INNER SHELF COOL CABINET (M)**

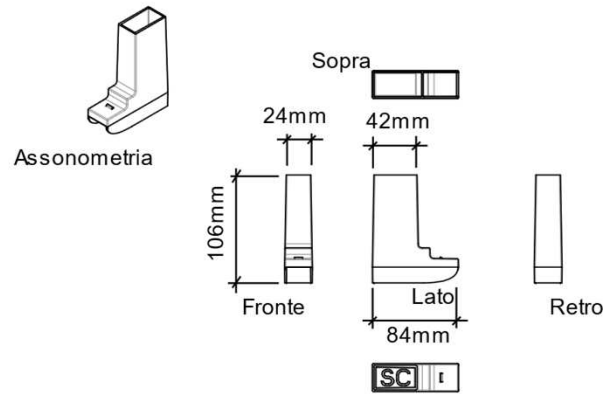

**SC**

**SQUARE POLE BASE (SC)**

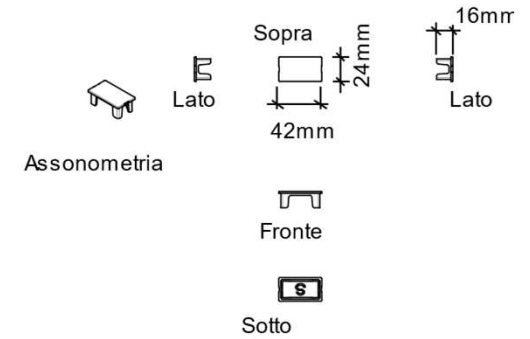

**S**

**TOP CAP INNER SHELF (S)**



- Material shrinkage coefficient (PP): 1.8%
- Tolerance on indicated dimensions: +/- 0,5 mm
- Texture: Same of other molds of the same product family
- Color: black PP (4000022)

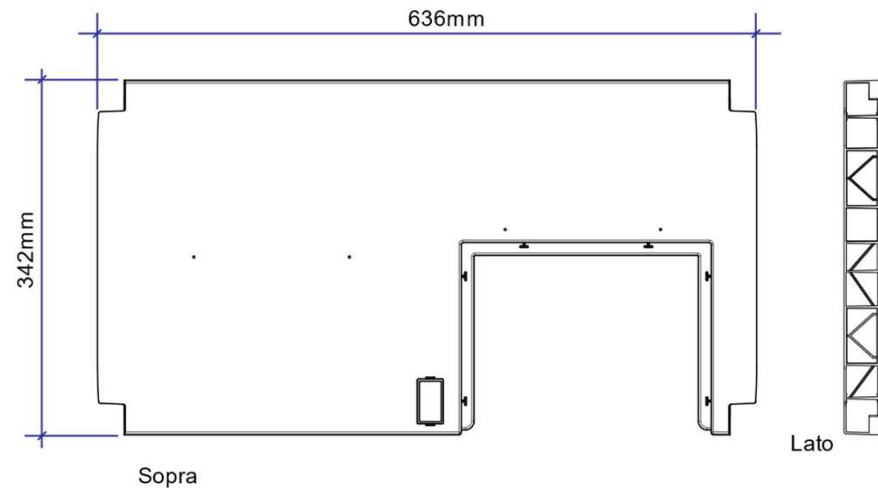
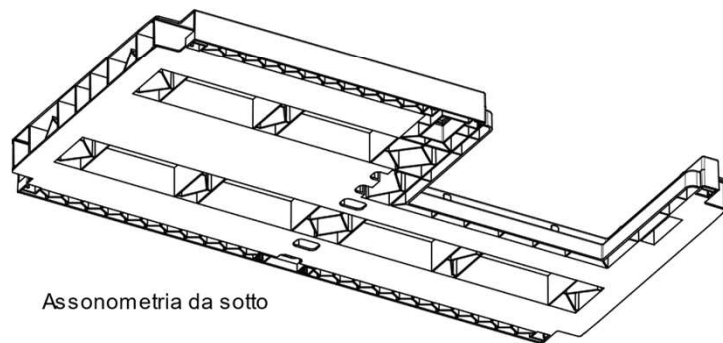
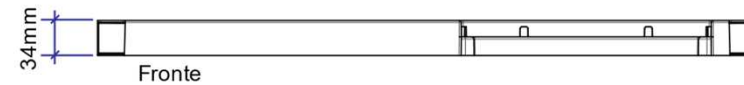
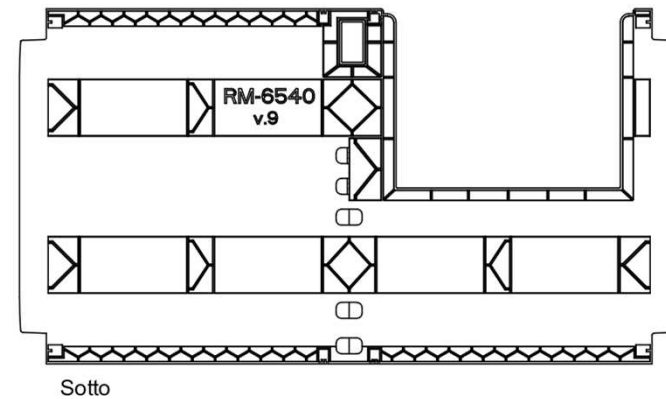
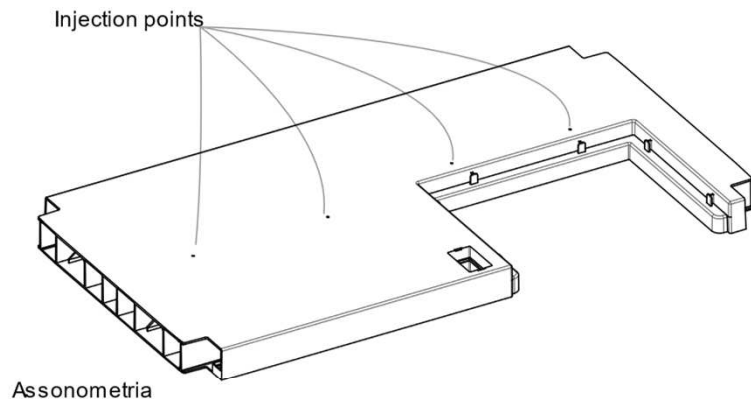

RM

NEW CONVERTIBLE INNER SHELF 65  
(RM)

- Material shrinkage coefficient (PP): 1.8%
- Texture: Same of other molds of the same product family
- Color: black PP (4000022)

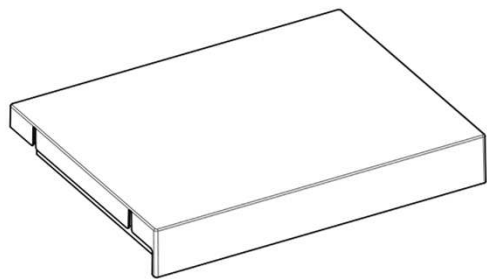

Assonometria

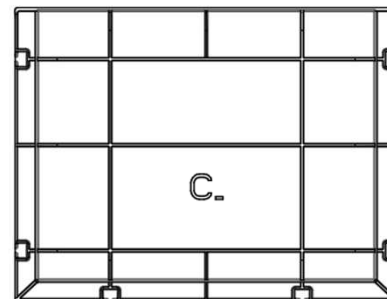

Sotto

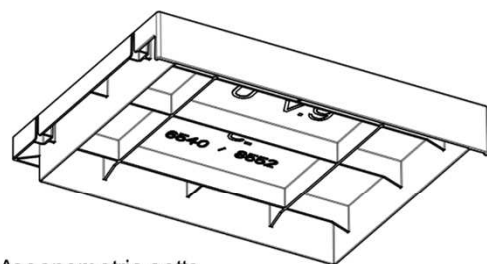

Assonometria sotto

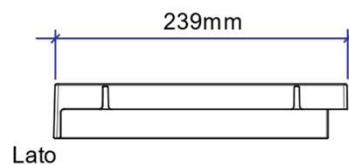

Lato

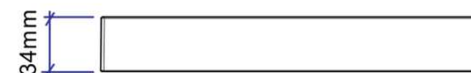

Fronte

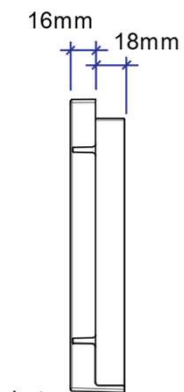

Lato

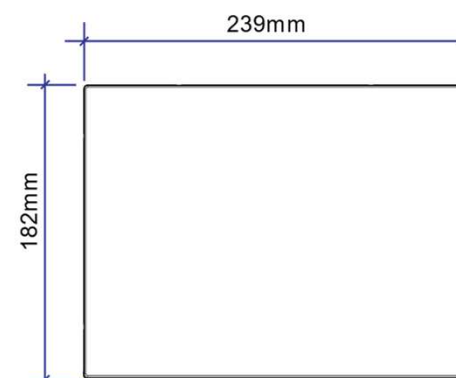

Sopra

C

NEW INNER SHELF INSERT (C)

- Material shrinkage coefficient (PP): 1.8%
- Texture: Same of other molds of the same product family
- Color: black PP (4000022)
- Color: grey PP (4000024)

**NEW HANDLE KIT EVO (K1+K2+K)**

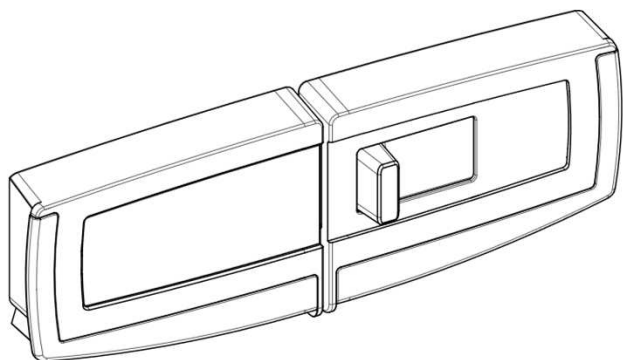

Assonometria

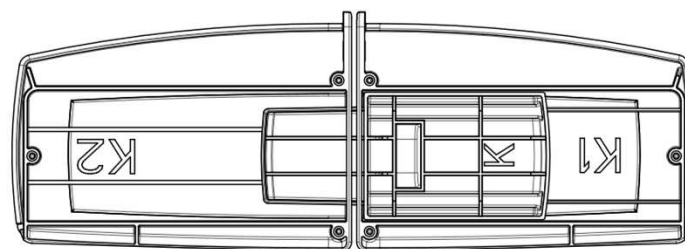

Retro

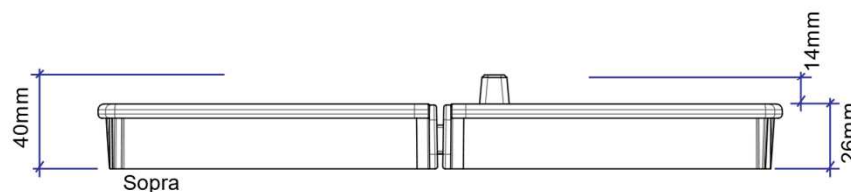

Sopra

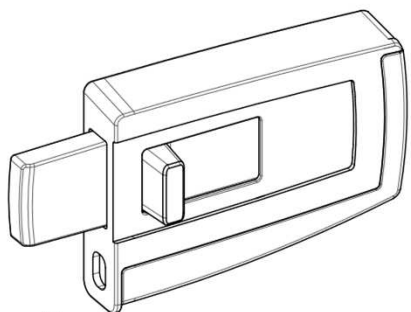

Assonometria

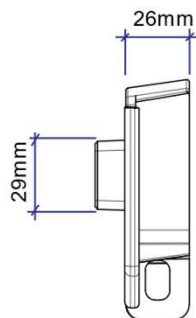

Lato

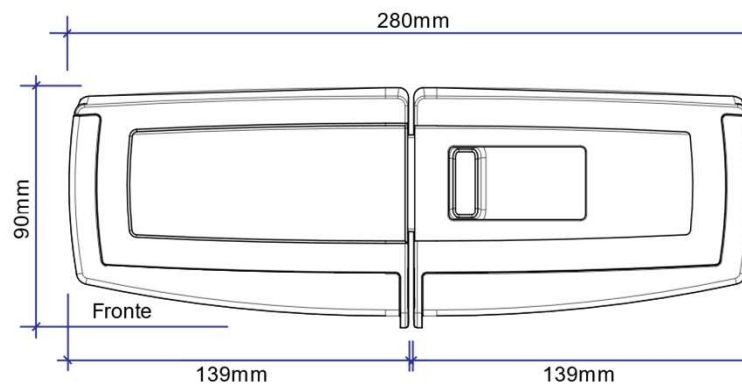

Fronte

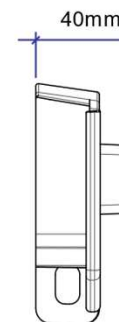

Lato

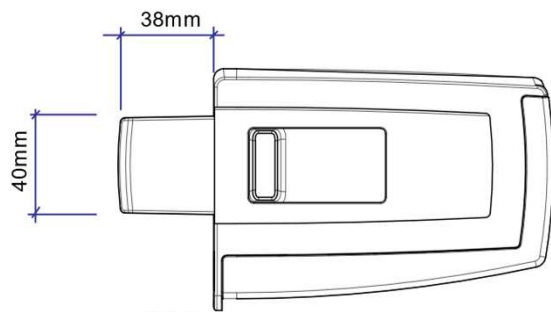

Fronte

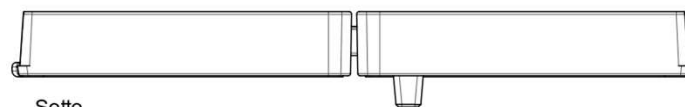

Sotto

