

Technical drawings with tolerances

L3 range

HIGH RESIN CABINET XL 85 CM

MATRIX ID - 2022R14P02-0017

Gtin 13: 3276007359251



HIGH RESIN CABINET XL 85 CM

2022R14P02-0017

180 cm

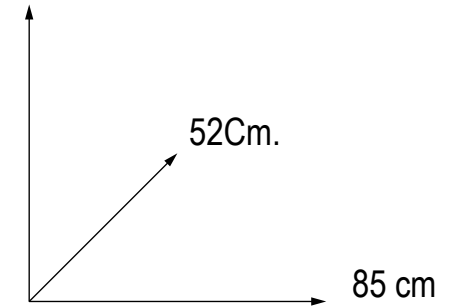

Tolerance on overall dimensions: +/- 10 mm

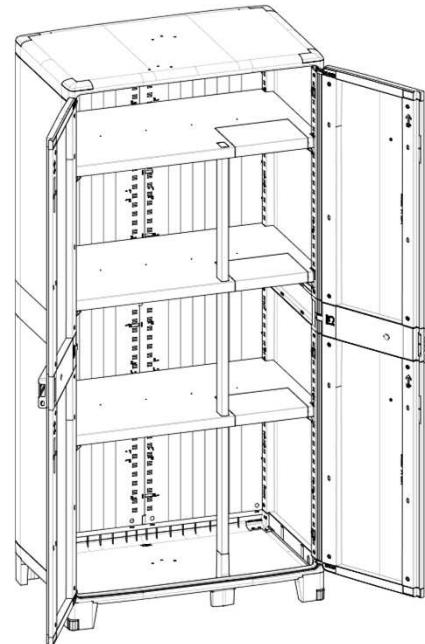
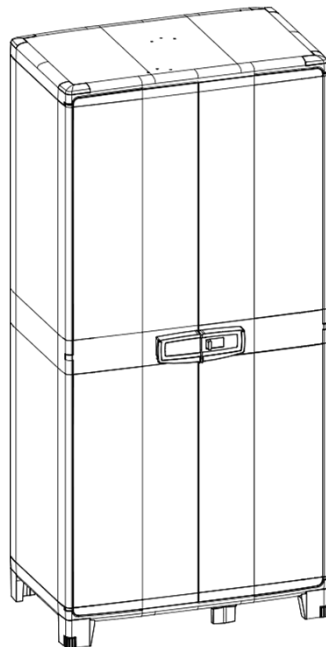

Overall gross weight (including packaging) : 23.00 gr with tolerance of +/- 5%

Exploded View

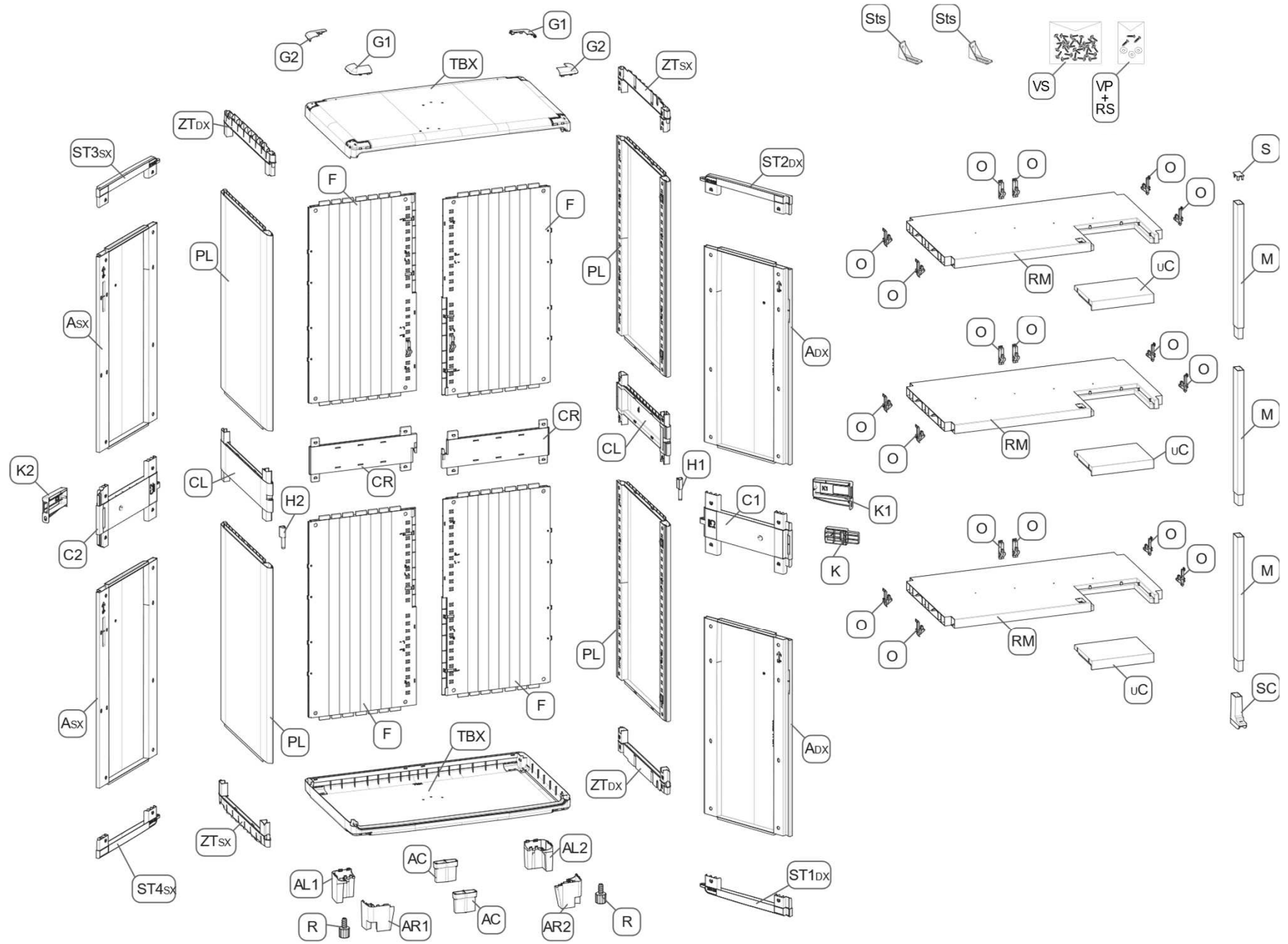

- Material shrinkage coefficient (PP): 1.8%
- Tolerance on indicated dimensions: +/- 0,5 mm
- Texture: Same of other molds of the same product family
- Color: grey PP (4000024)

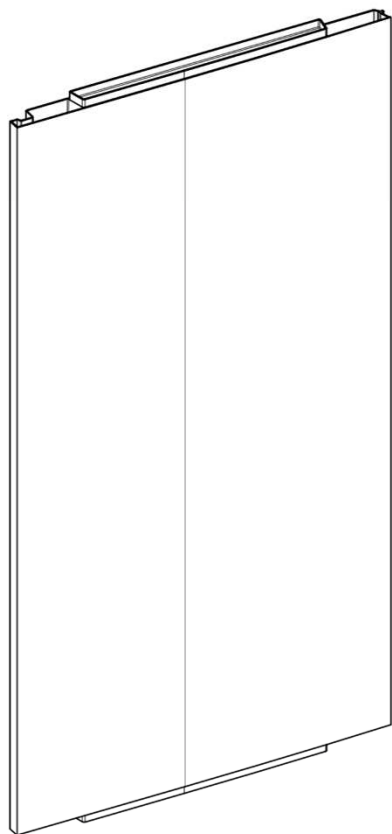

Assonometria

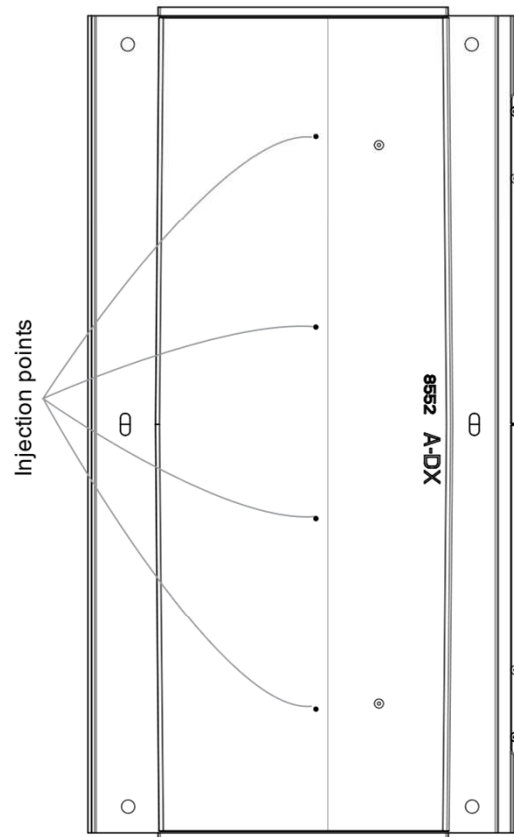

Retro

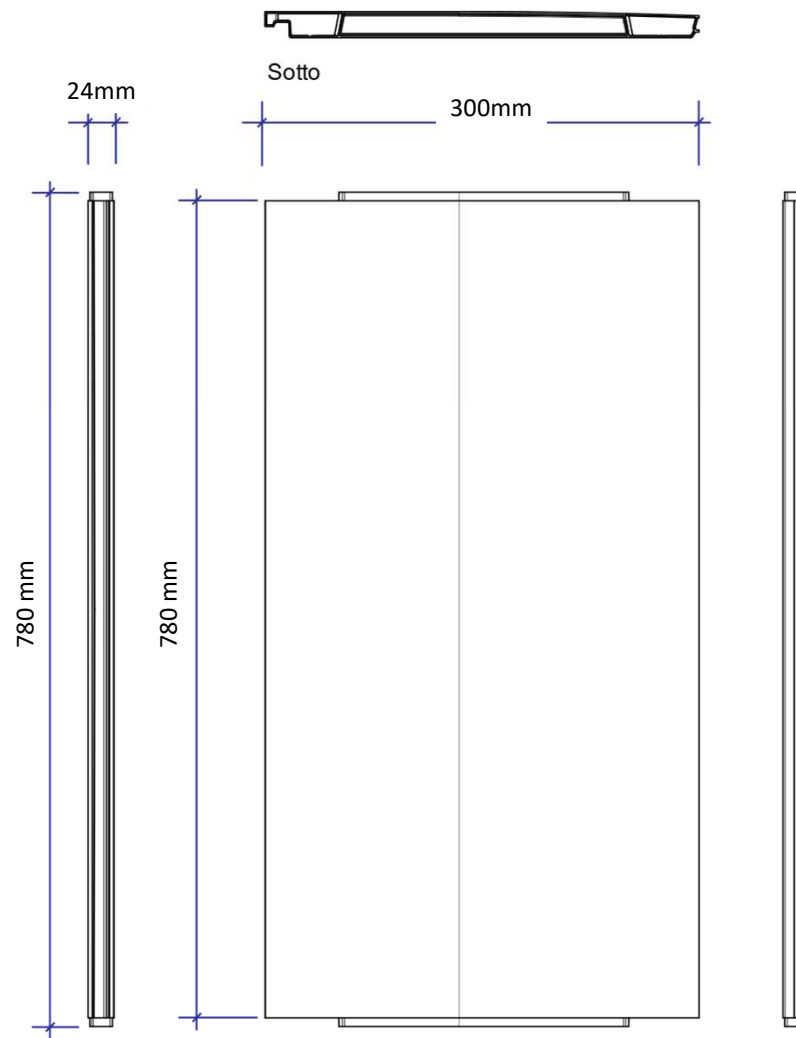

Lato

Fronte

ADX

New Front Panel 85 EVO DX (Adx)

- Material shrinkage coefficient (PP): 1.8%
- Tolerance on indicated dimensions: +/- 0,5 mm
- Texture: Same of other molds of the same product family
- Color: grey PP (4000024)

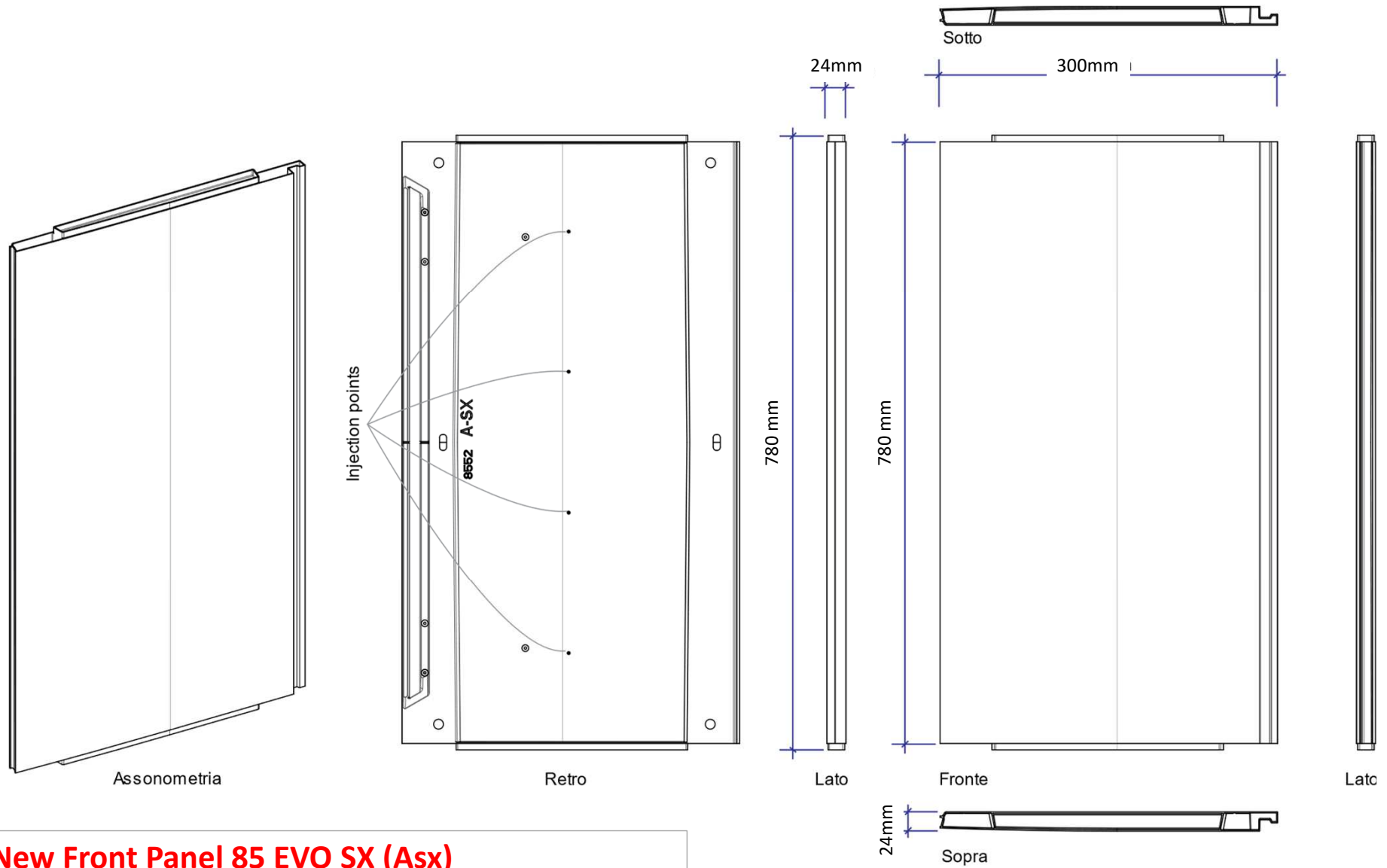

ASX

New Front Panel 85 EVO SX (Asx)

- Material shrinkage coefficient (PP): 1.8%
- Tolerance on indicated dimensions: +/- 0,5 mm
- Texture: Same of other molds of the same product family
- Color: black PP (4000022)

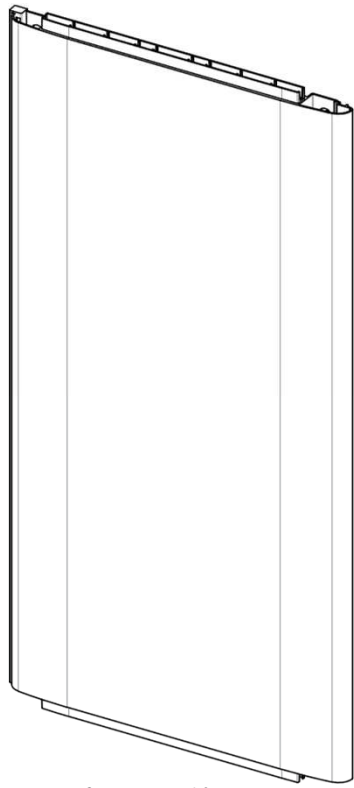

Assonometria

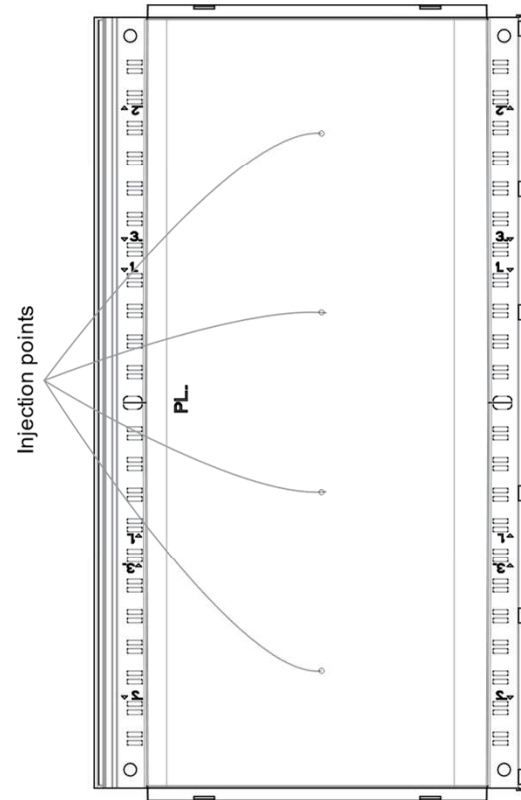

Injection points

Retro

28mm

752,3 mm

Lato

776 mm



Sotto

385mm
515mm

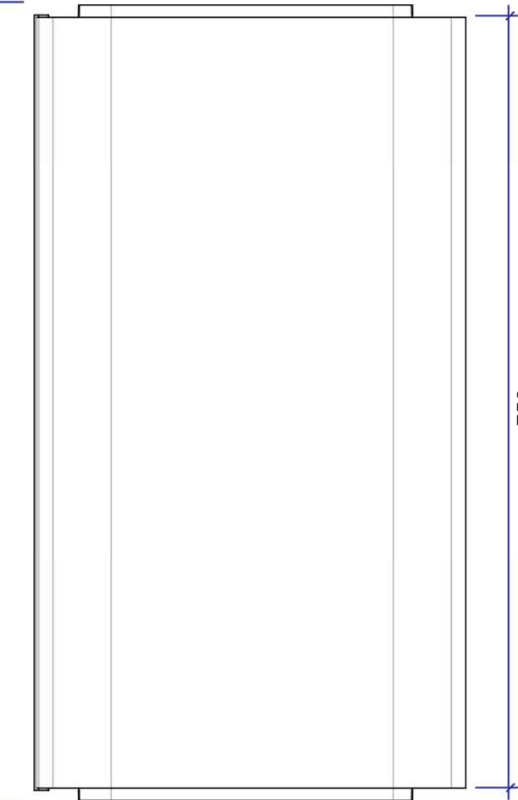

Fronte

752mm

28mm



Sopra

PL

Side Panel 85 (PL)

- Material shrinkage coefficient (PP): 1.8%
- Tolerance on indicated dimensions: +/- 0,5 mm
- Texture: Same of other molds of the same product family
- Color: black PP (400022)

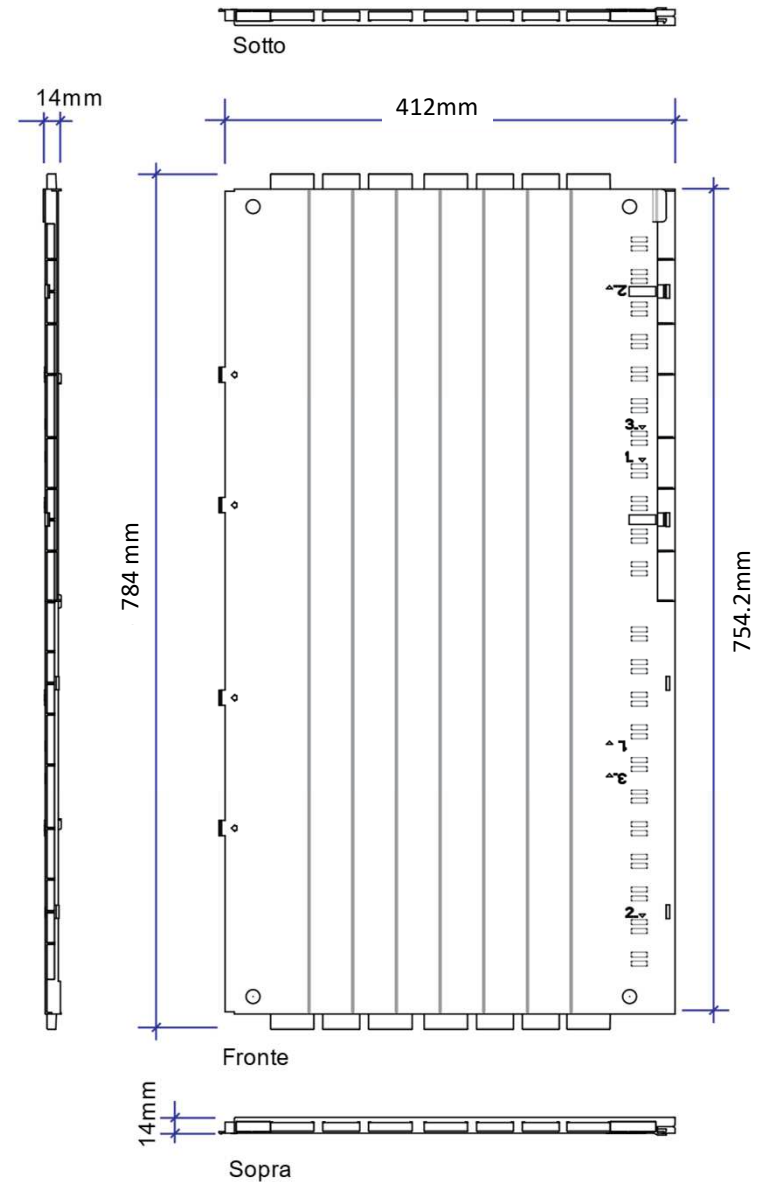
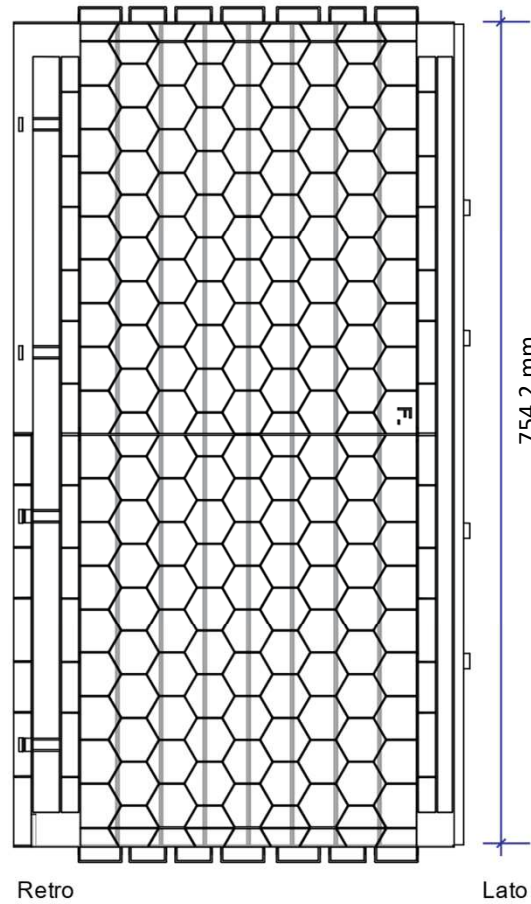
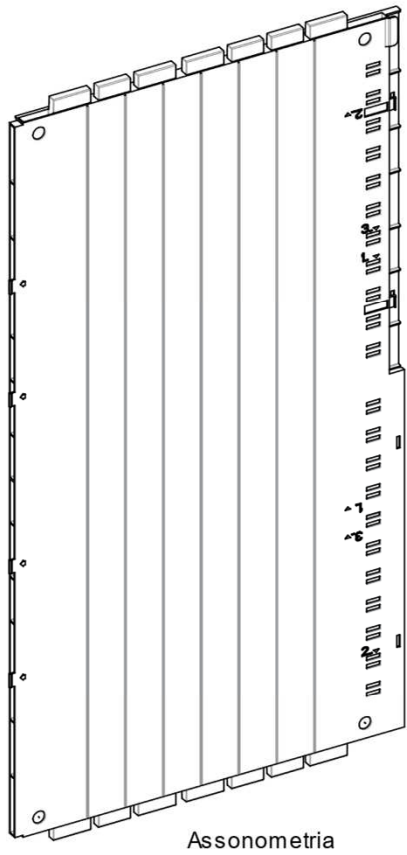

F

Back Panel 85 (F)

- Material shrinkage coefficient (PP): 1.8%
- Tolerance on indicated dimensions: +/- 0,5 mm
- Texture: Same of other molds of the same product family
- Color: black PP (400022)

Top Bottom 85 (TBX)

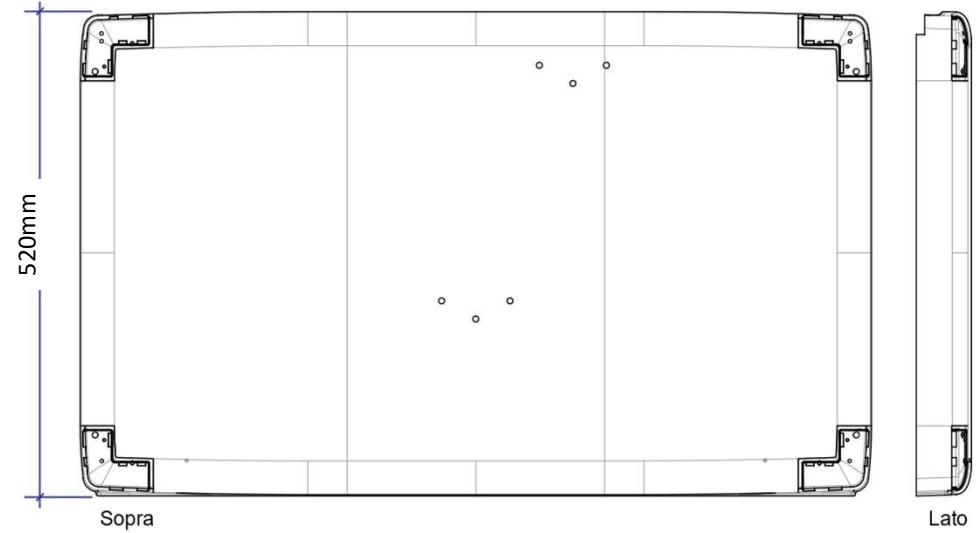
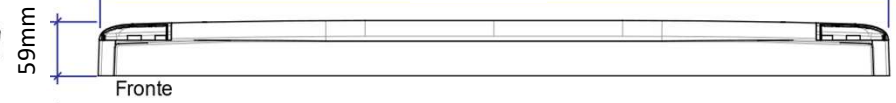
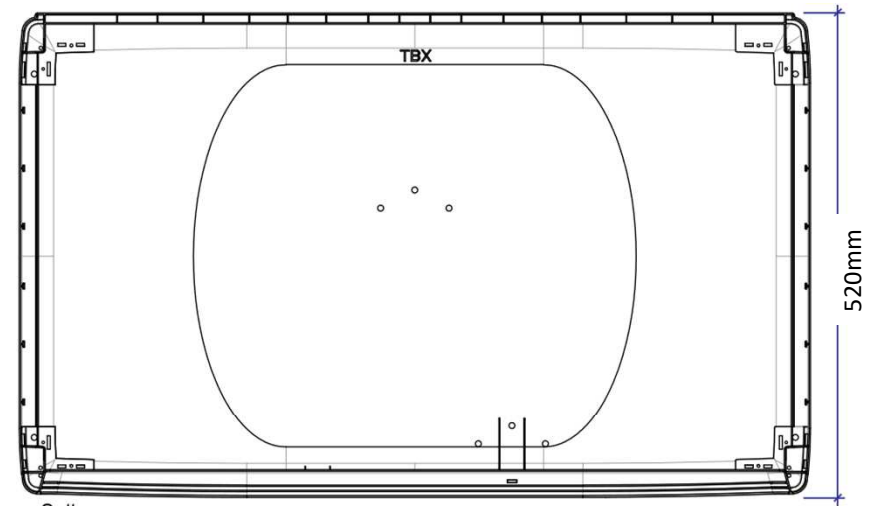
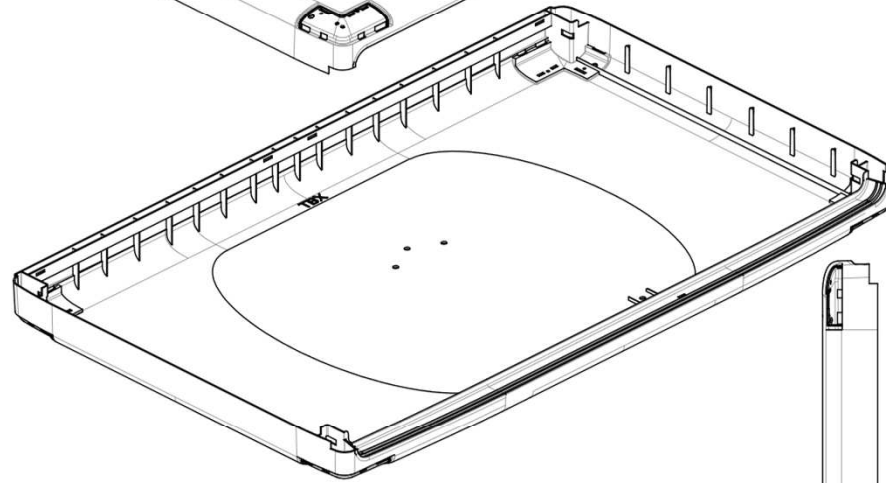
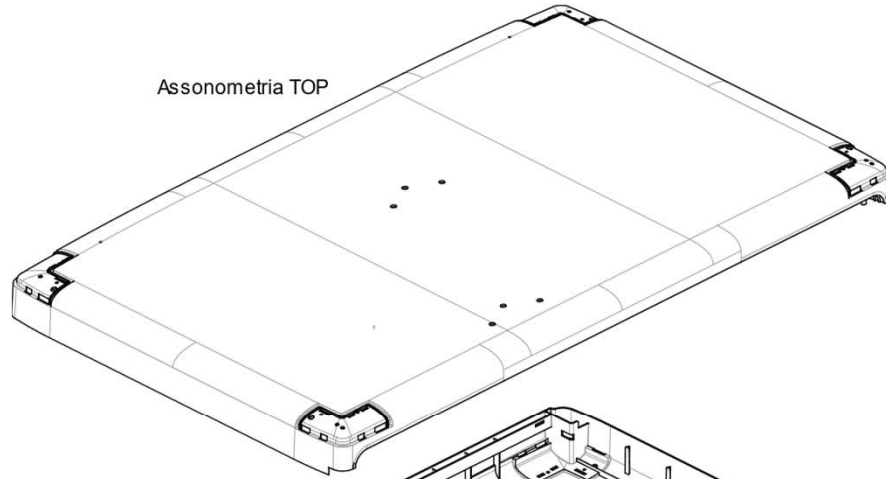

TBX

- Material shrinkage coefficient (PP): 1.8%
- Texture: Same of other molds of the same product family
- Color: grey PP (4000024)

New kit end caps inges 85 (ST)

ST3sx

(#3)Top hinge SX

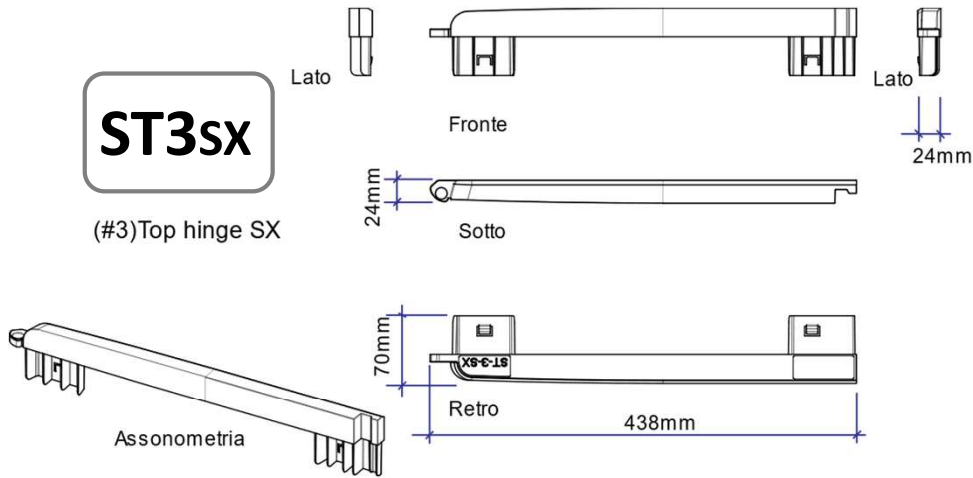

ST2DX

(#2)Top hinge DX

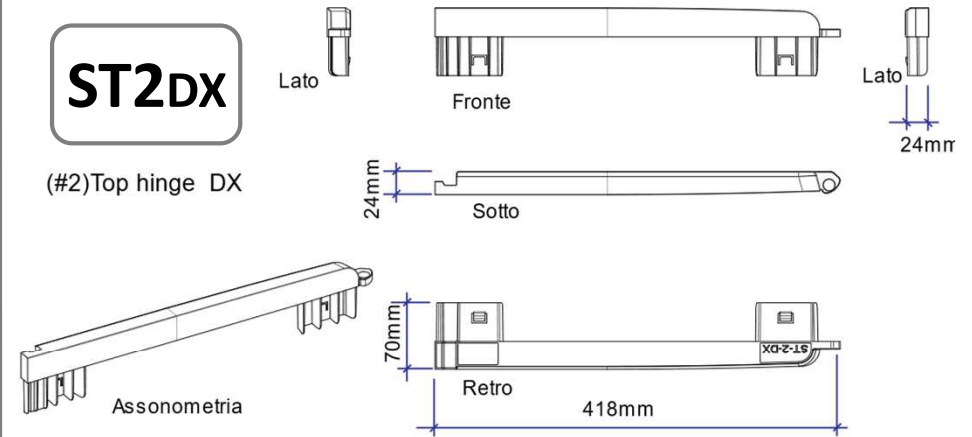

ST4sx

(#4)Botton hinge SX

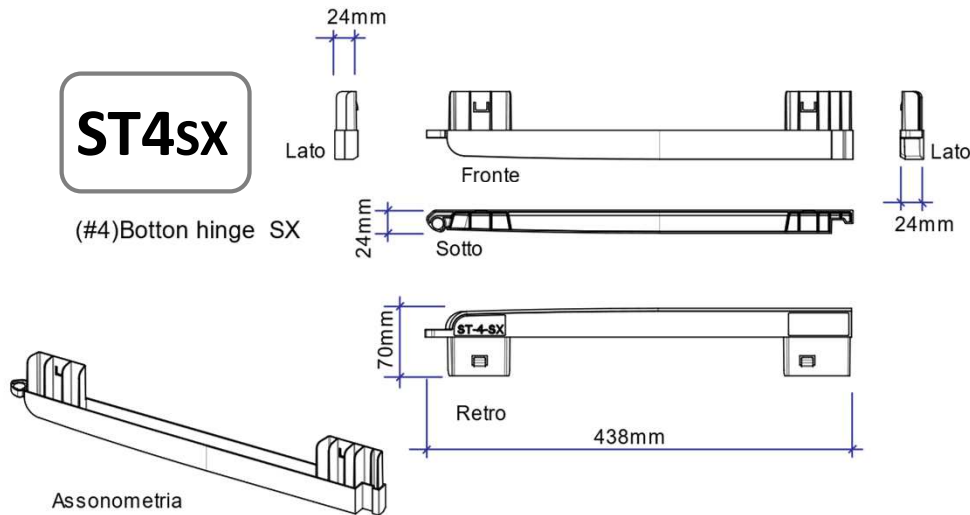

ST1DX

(#1)Botton hinge DX

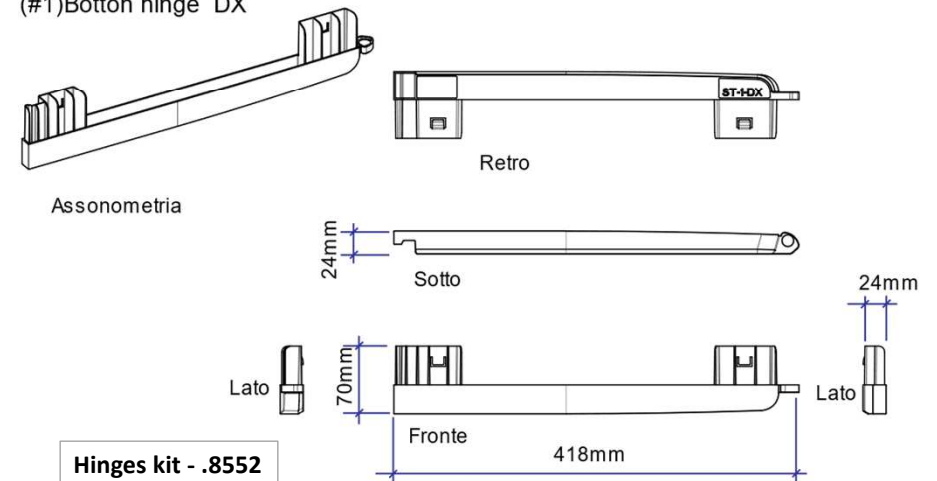

- Material shrinkage coefficient (PP): 1.8%
- Texture: Same of other molds of the same product family
- Color: grey PP (4000024)

New EVO belt doors (C1+C2)

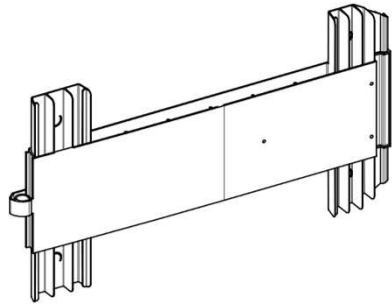

Assonometria

C2

Front belt SX

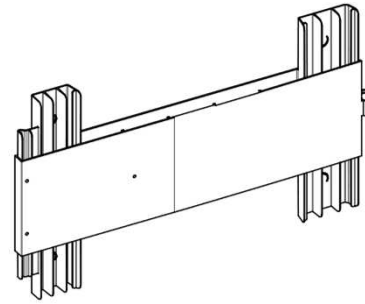
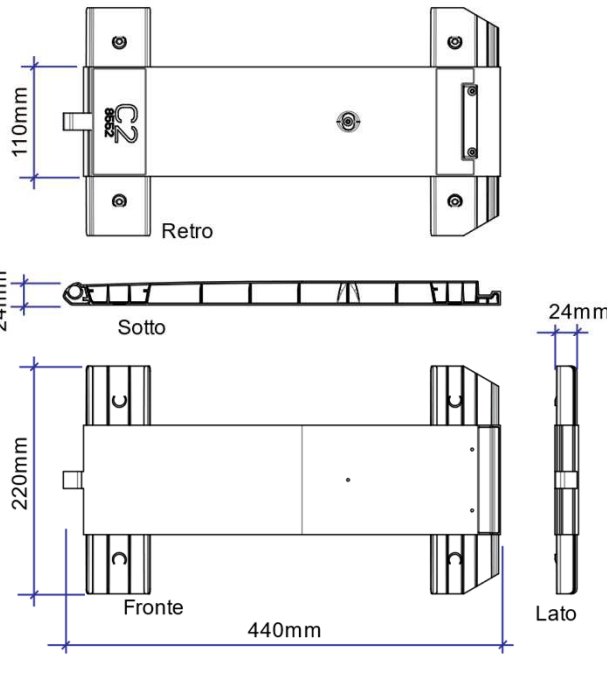

Assonometria

C1

Front belt DX

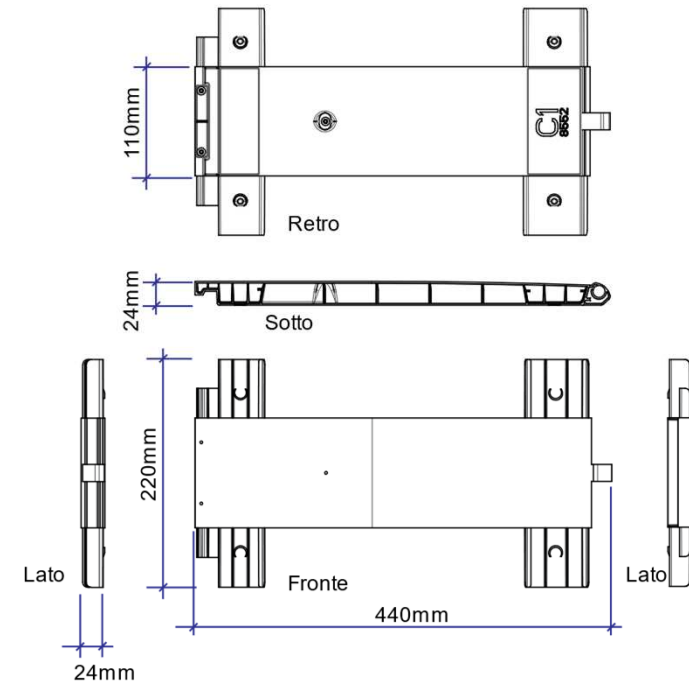

Front belt kit - .8552

- Material shrinkage coefficient (PP): 1.8%
- Texture: Same of other molds of the same product family
- Color: black PP (4000022)

Side+Back Belt Kit 85 (CL+CR)

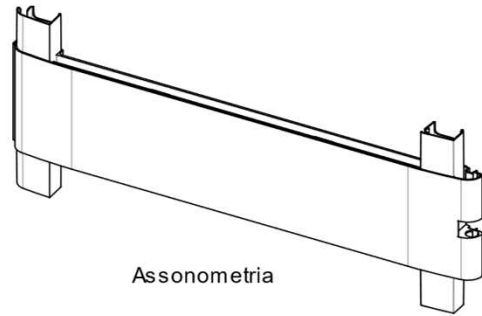

CL

Assonometria

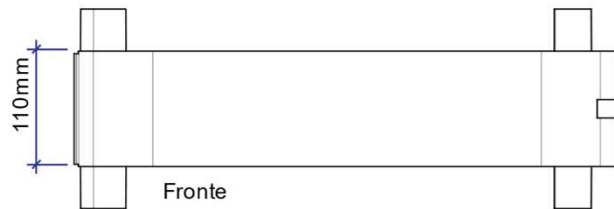

Fronte



Sopra

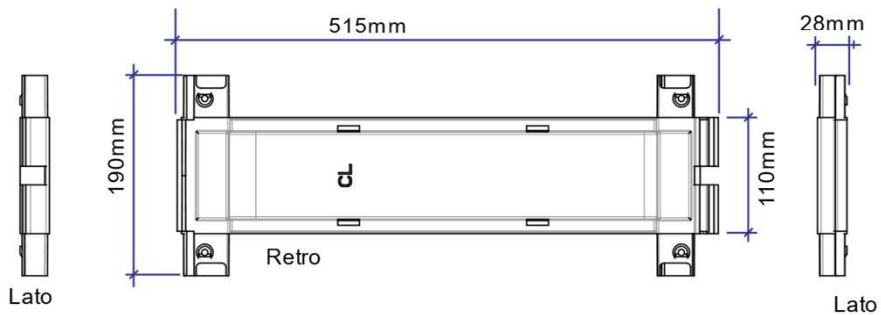

Retro

Lato



Sotto

CR

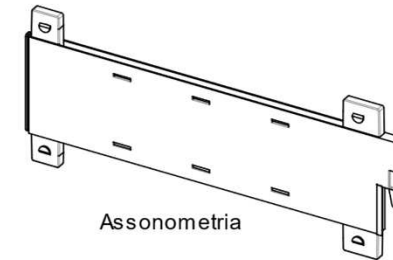

Assonometria

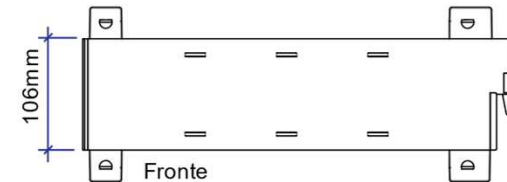

Fronte

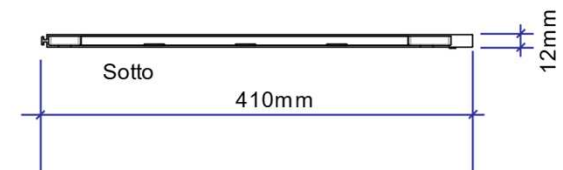

Sotto



Lato

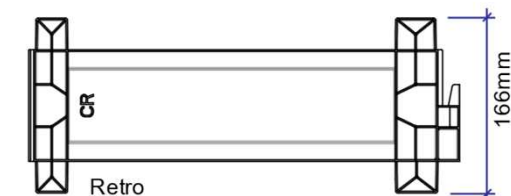

Retro

Lato



Sopra

- Material shrinkage coefficient (PP): 1.8%
- Texture: Same of other molds of the same product family
- Color: black PP (4000022)

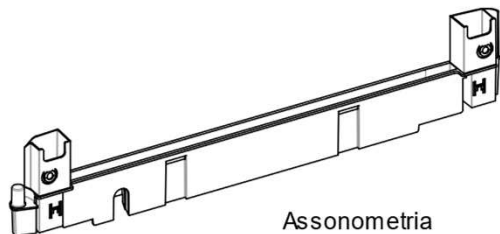

Assonometria

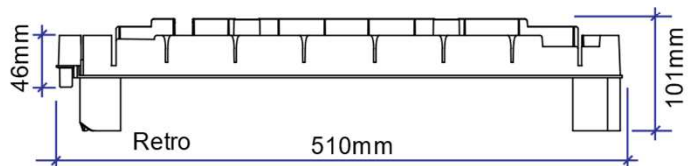

Sotto

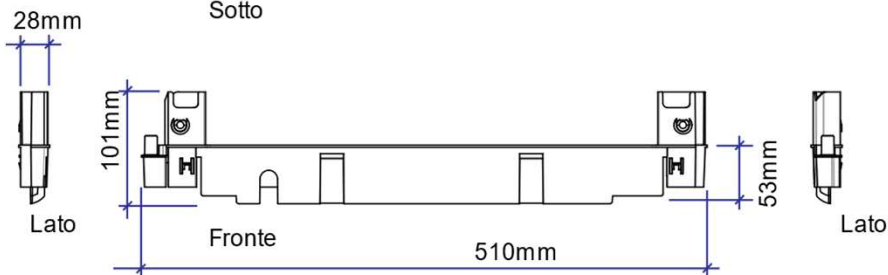

Sopra

ZTsx

Kit Top-bottom inserts Top 85 (ZTsx+ZTdx)

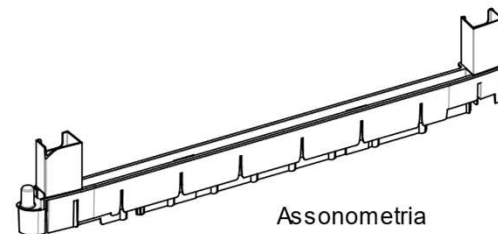

Assonometria

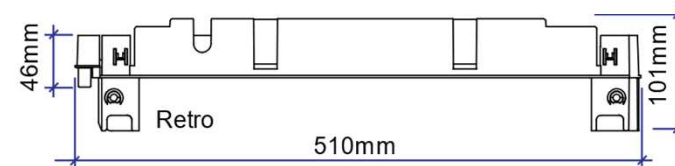

Sotto

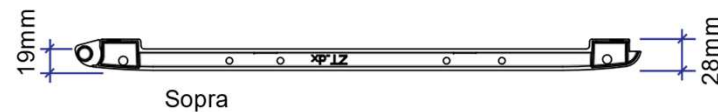
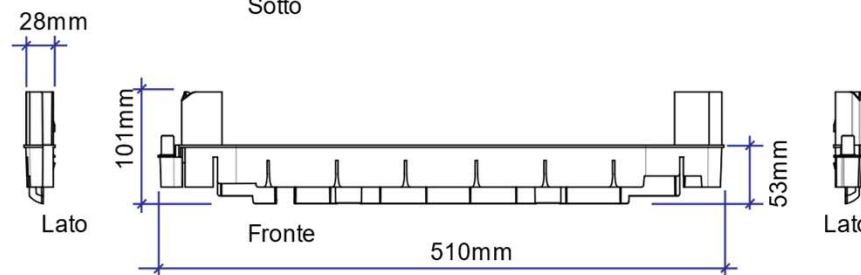

Sopra

ZTdx

- Material shrinkage coefficient (PP): 1.8%
- Texture: Same of other molds of the same product family
- Color: black PP (4000022)



Assonometria

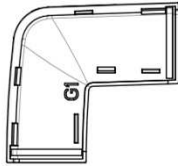

Sotto

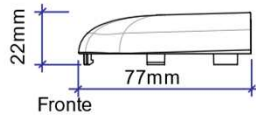

Fronte

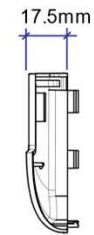

Lato

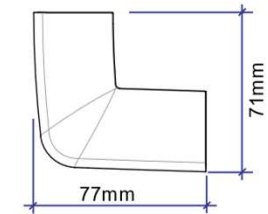

Sopra



Lato

G1

Kit Top end caps cool cabinets (G1+G2)

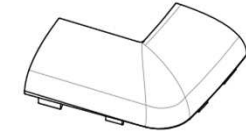

Assonometria

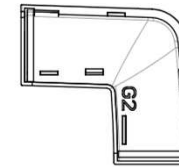

Sotto

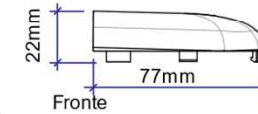

Fronte

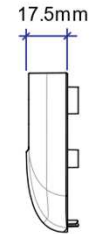

Lato

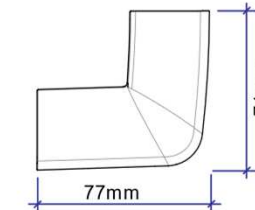

Sopra



Lato

G2

- Material shrinkage coefficient (PP): 1.8%
- Texture: Same of other molds of the same product family
- Color: black PP (4000022)

**KIT FEET COOL CABINETS
(AC+AL+AR+R)**

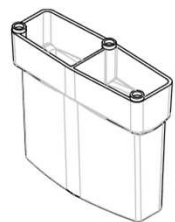

Assonometria



Sotto
80mm 28mm



Lato

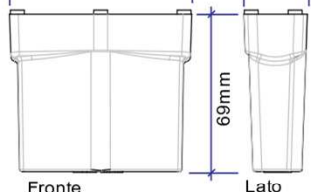

Fronte

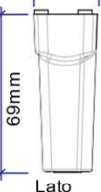

Lato



Sopra

AC

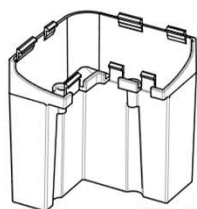

Assonometria

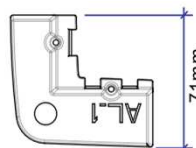

Sotto
78mm 71mm

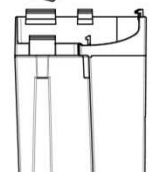

Lato

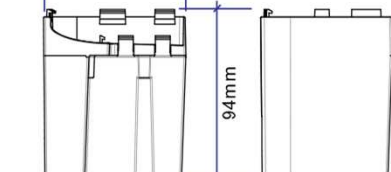

Fronte

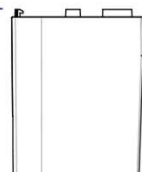

Lato



Sopra

AL1

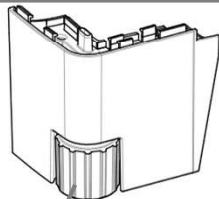

Assonometria

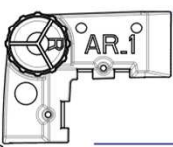

Sotto
92mm 71mm

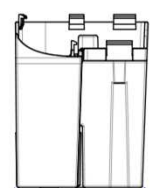

Lato

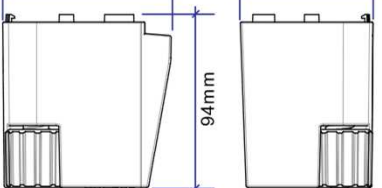

Fronte

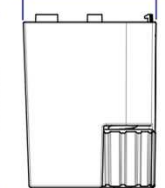

Lato

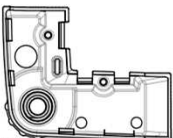

Sopra

AR1

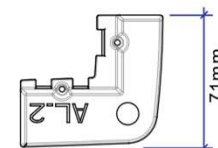

Sotto
78mm 71mm

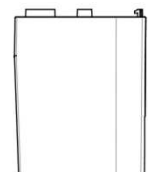

Lato

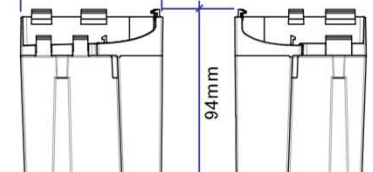

Fronte

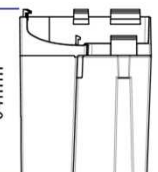

Lato

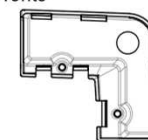

Sopra

AL2

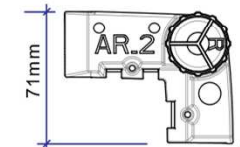

Sotto
92mm 71mm

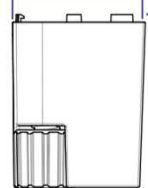

Lato

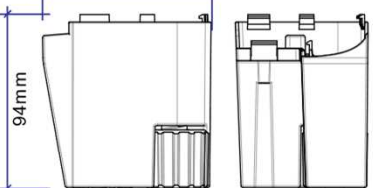

Fronte

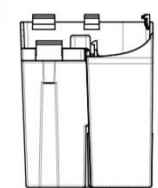

Lato

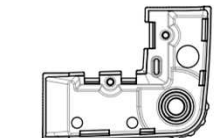

Sopra

AR2

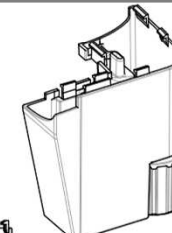

Assonometria

R

- Material shrinkage coefficient (PP): 1.8%
- Texture: Same of other molds of the same product family
- Color: grey PP (4000024)

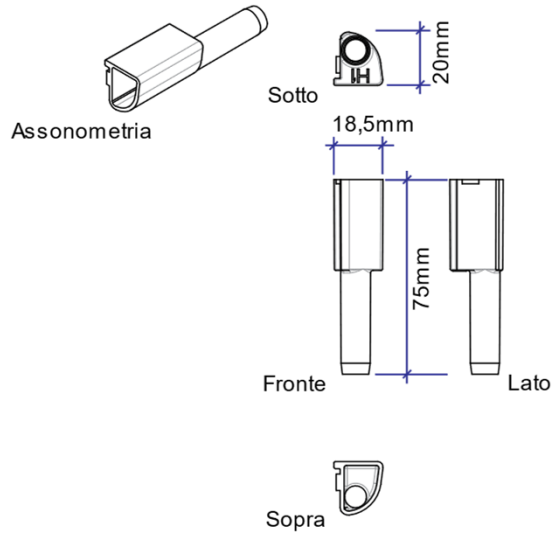

H1

New EVO 85 Hinges (H1+H2)

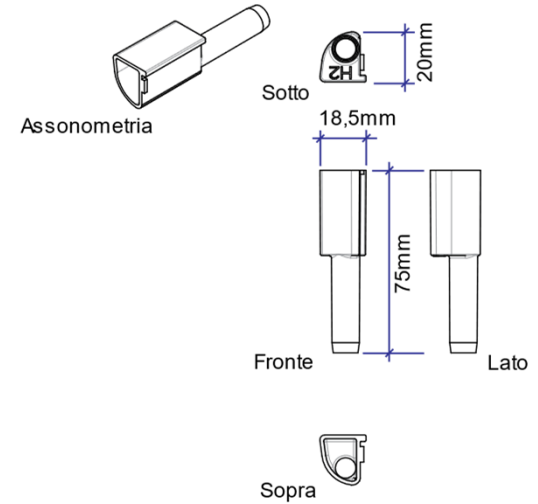

H2

- Material shrinkage coefficient (PP): 1.8%
- Texture: Same of other molds of the same product family
- Color: black PP (4000022)

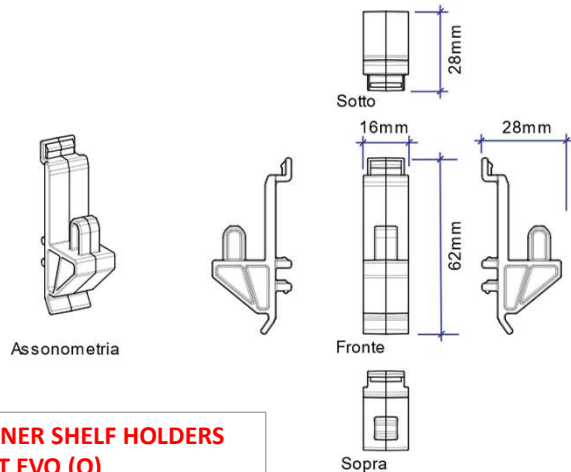

O

**INNER SHELF HOLDERS
KIT EVO (O)**

- Material shrinkage coefficient (PP): 1.8%
- Texture: Same of other molds of the same product family
- Color: black PP (4000022)

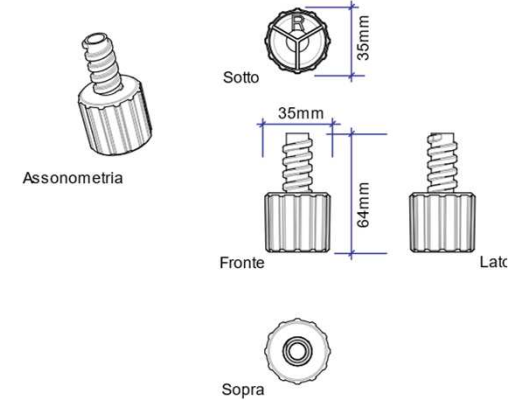

R

Kit feet cool cabinets (R)

- Material shrinkage coefficient (PP): 1.8%
- Texture: Same of other molds of the same product family
- Color: black PP (4000022)

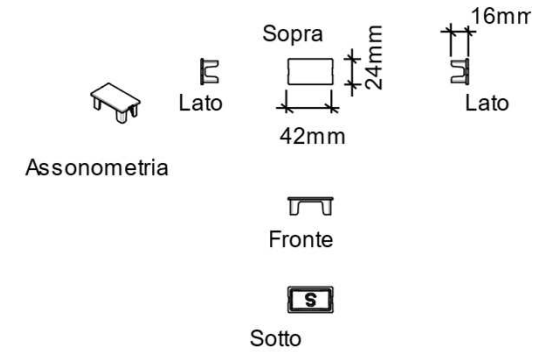
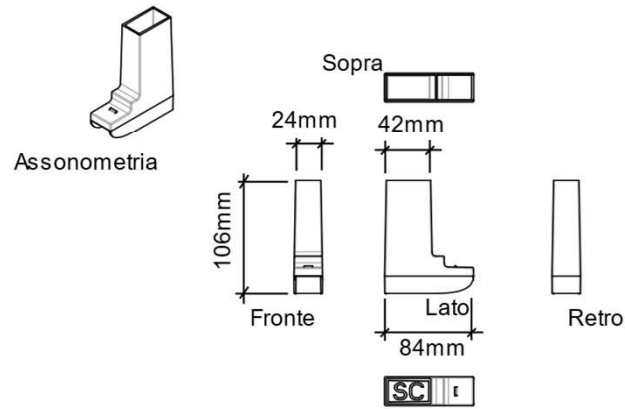
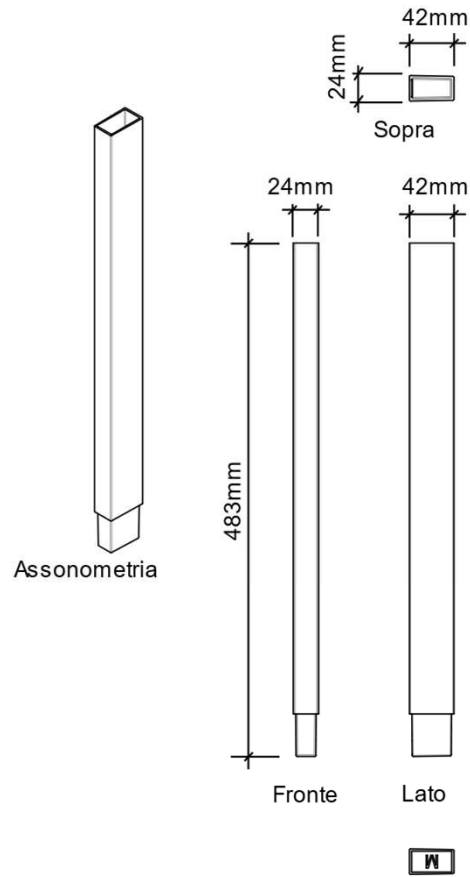

M

SQUARE POLE FOR INNER SHELF COOL CABINET (M)

SC

SQUARE POLE BASE (SC)

S

TOP CAP INNER SHELF (S)

- Material shrinkage coefficient (PP): 1.8%
- Tolerance on indicated dimensions: +/- 0,5 mm
- Texture: Same of other molds of the same product family
- Color: black PP (4000022)

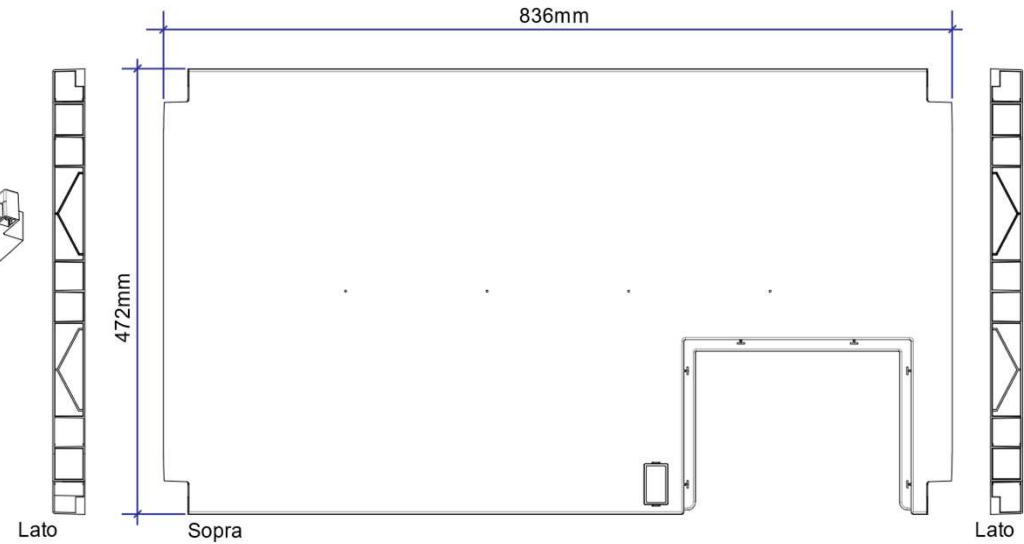
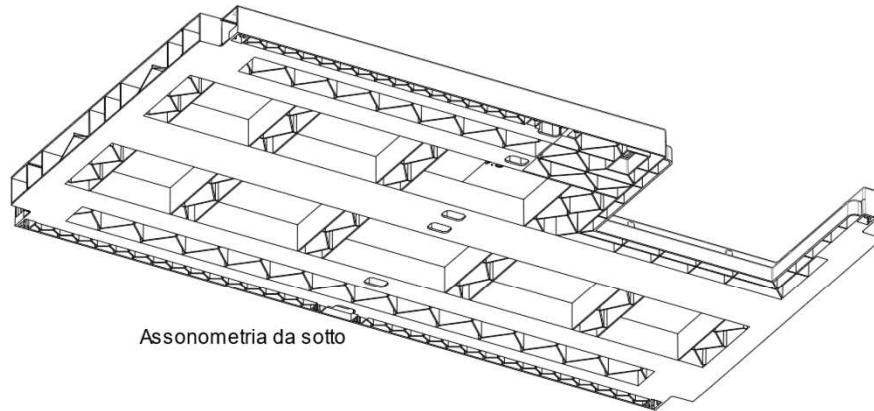
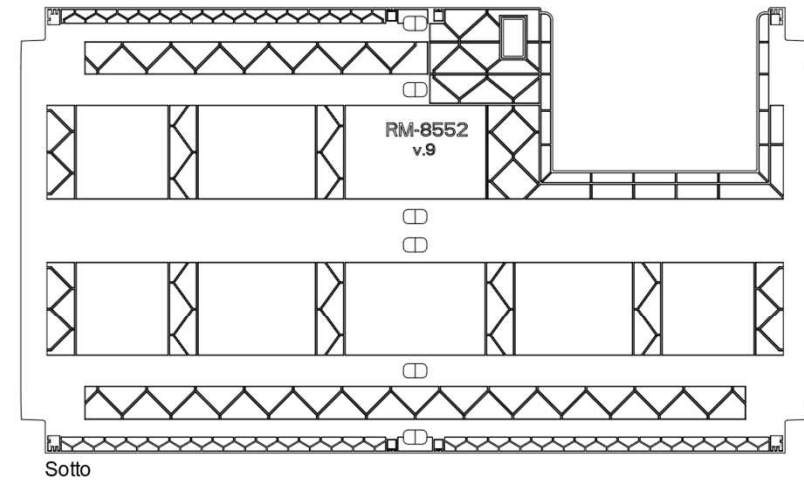
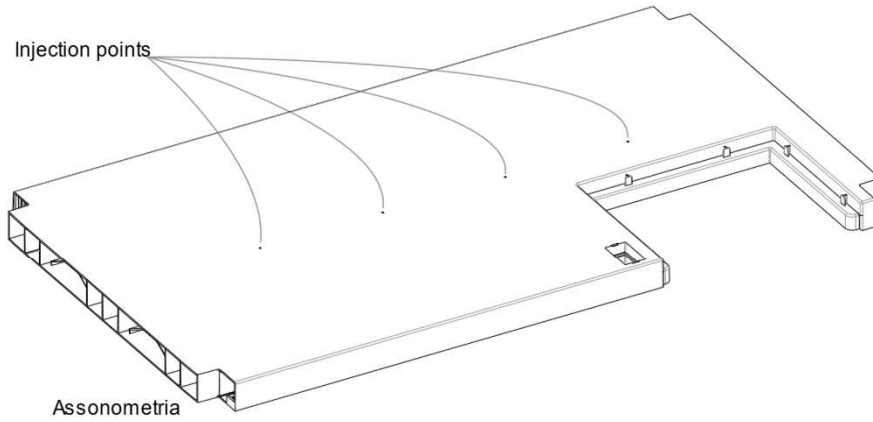

RM

NEW CONVERTIBLE INNER SHELF 85 (RM)

- Material shrinkage coefficient (PP): 1.8%
- Texture: Same of other molds of the same product family
- Color: black PP (4000022)

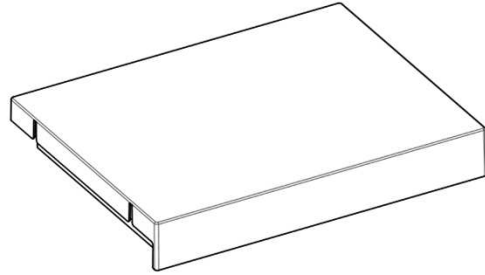

Assonometria

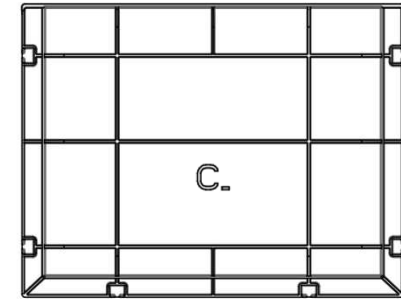

Sotto

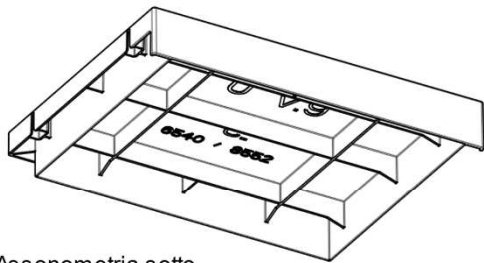

Assonometria sotto

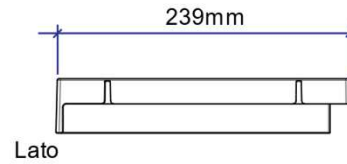

Lato



Fronte

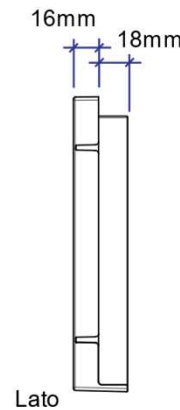

Lato

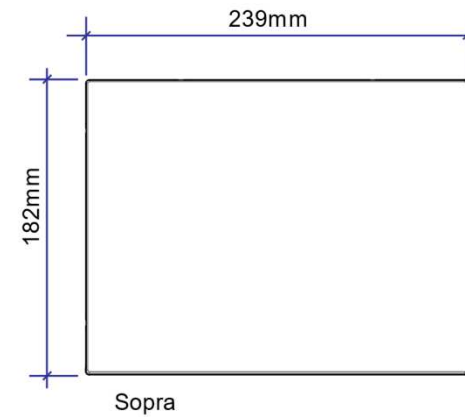

Sopra

C

NEW INNER SHELF INSERT (C)

- Material shrinkage coefficient (PP): 1.8%
- Texture: Same of other molds of the same product family
- Color: black PP (4000022)
- Color: grey PP (4000024)

NEW HANDLE KIT EVO (K1+K2+K)

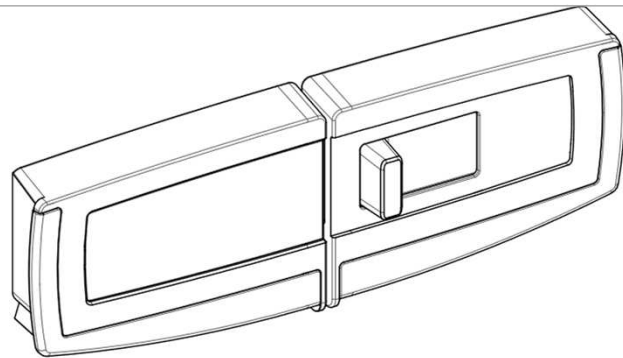

Assonometria

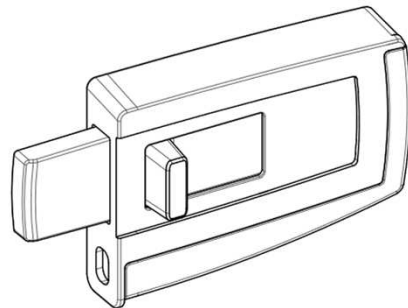

Assonometria

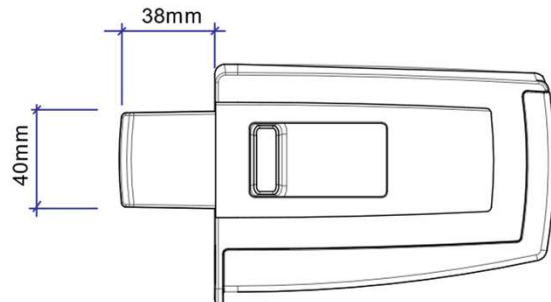

Fronte

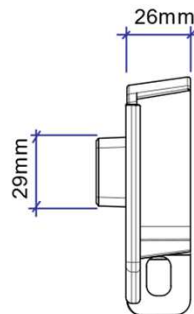

Lato

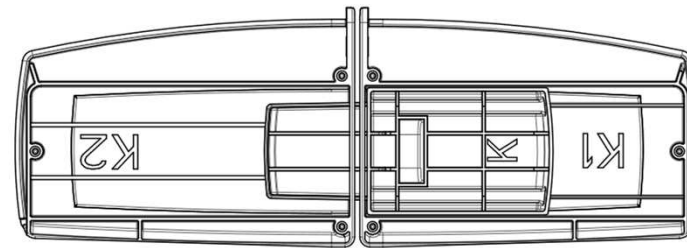

Retro

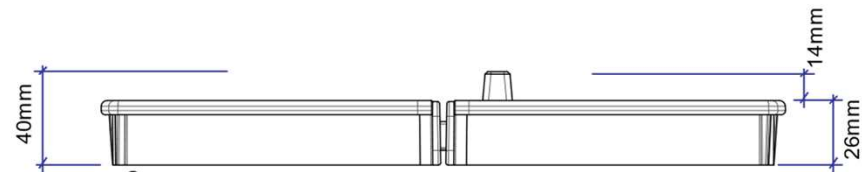

Sopra

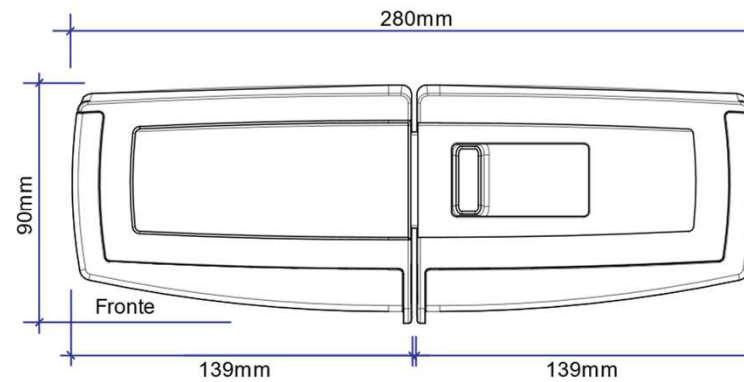

Fronte

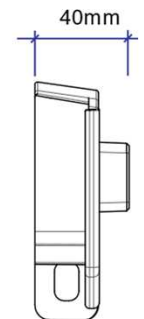

Lato

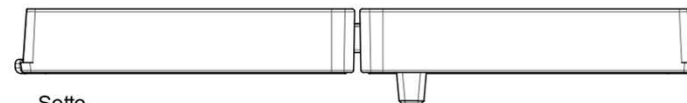

Sotto

K1

K2

K

Handle kit - .6540 - .8552