

No. ARTICLE	NUMERO DE PIECE	DESCRIPTION	QTE
1	21R07P21-0001-040-11	BOTTOM	1
2	21R07P21-0001-060-01	CROSS BAR	2
3	21R07P21-0001-080-02	MIDDLE PANEL	1
4	21R07P21-0003-070-12	SHELF	1
5	ADEO-0001-0002	Euroscrew countersunk PZ2 D6.2x13.5	4
6	ADEO-0002-0001	Wood dowel D8x30	6
7	ADEO-0002-0002	Wood dowel D5x30	4
8	ADEO-0002-0003	Eccentric box P12 D15	8
9	ADEO-0002-0004	Eccentric axle L34	8
10	ADEO-0003-0002	Wall cabinet hanger 1 (Metal bracket)	2
11	ADEO-0003-0003	Wall cabinet hanger 1 (Metal plate)	2
12	ADEO-0003-0004	Wall cabinet hanger 1 (Plastic cover)	2
13	ADEO-0003-0007	Metal console 82x30x100x1.5	1
14	ADEO-0004-0004	Shelf support pin D5 with lug plug	4

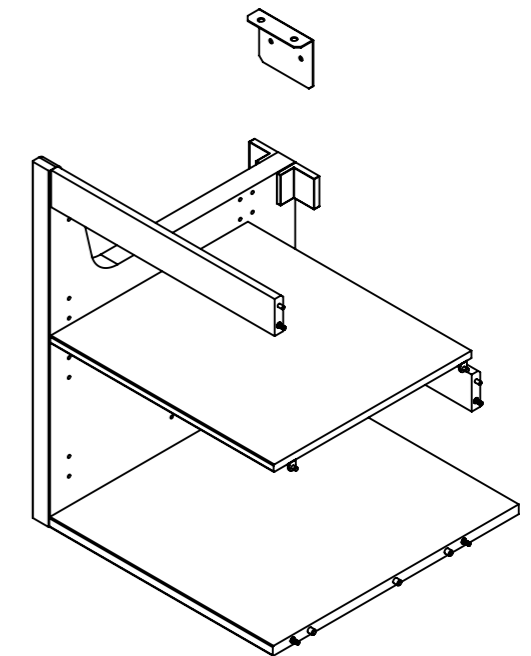

MATERIAL:	DO NOT SCALE DRAWING		SHEET 1 OF 1
SURFACE:	TITLE: 21R07P21-0001-005-02 A		
LINEAR TOLERANCE:	mm	DESCRIPTION: EXTENSION 450 DEPTH 480 - DOOR	
ANGULAR TOLERANCE:	deg		
WEIGHT:	8513.20	g	
SCALE:	1:20	UNIT: mm	FORMAT: A3
AUTOR:	C.Dormegnie	CHECKER:	C.Dormegnie
STATUS:	DATE: 02/06/2021		
This drawing is the exclusive property of ADEO . Any reproduction in part or whole without the written permission of ADEO is prohibited.			

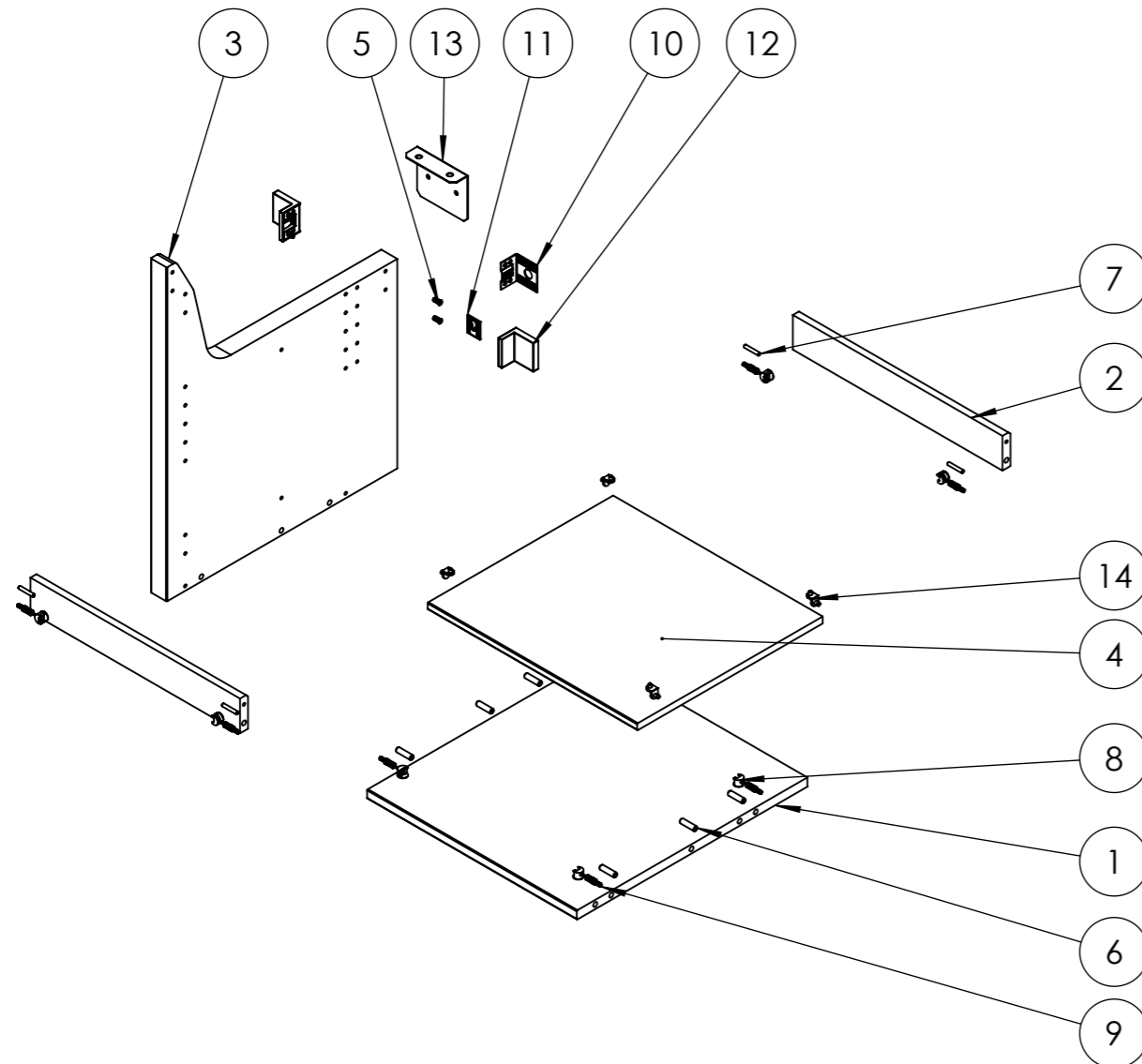
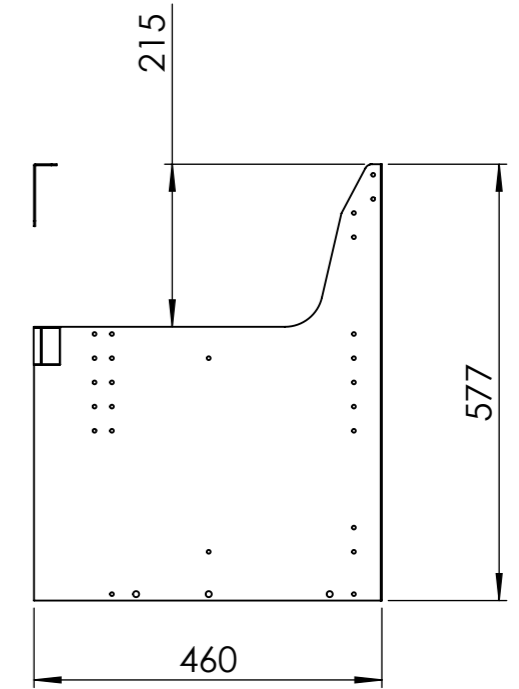
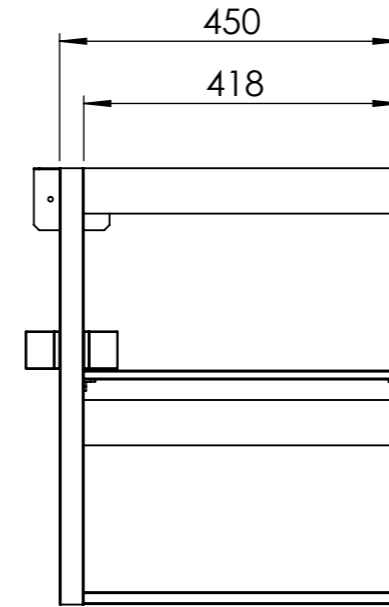