

C Detail
9:1

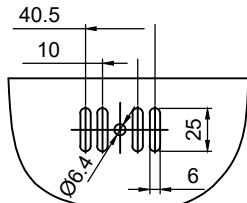

D Detail
(5:1)

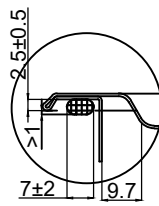

E Detail
16:1

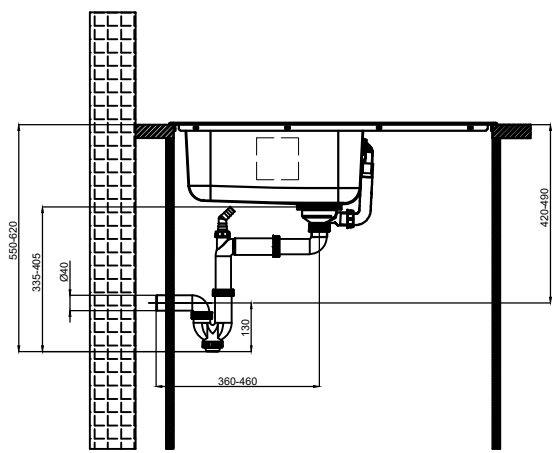
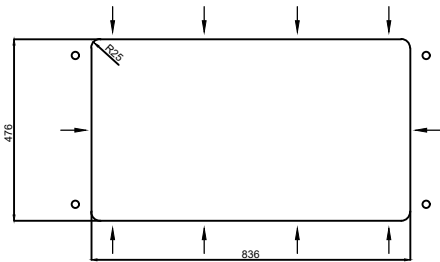
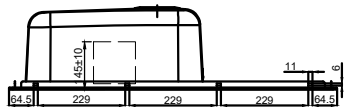
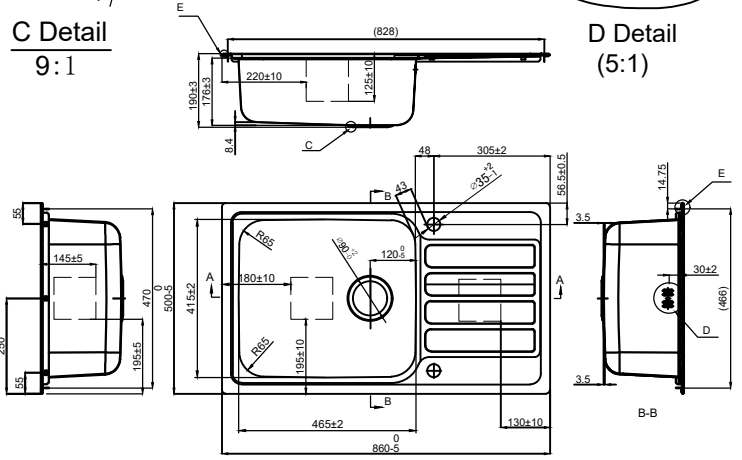

- 1.Pads must be installed aligned and centered on each face.
- 2.All dimensions in mm.
- 3.Pipes dimensions and tolerances as per NF-EN274-1-12-2002 and discharge pipes OD as per EN476:1997.
- 4.The flatness after assembly does not allow more than 1.0mm gap between the sink and the worktop in any points.
- 5.The seal is always bigger by 1mm minimum to ensure the contact with the worktop after installation.
- 6.The lateral sound pads will be mounted by the end user, the pads on the bottom and drainer will be pre-mounted.

Matrix code	Ref	Designation	Material grade	Quantity	Weight(kg)	Dimension(mm)	Supplier Reference	Finishings Colour
2025R17P08-0030	1	Sink	SUS304	1	4.88	860*500*215	1254S	Micro structured

GB/T 1804 -C							
Following general tolerances are applicable to all dimensions without any tolerances indicated specifically on the drawing.							
>0.5-3	>3-6	>6-30	>30-120	>120-400	>400-1000	>1000-2000	>2000-4000
±0.05	±0.3	±0.5	±0.8	±1.2	±2	±3	±4

Product/Serie designation (as per Synnertrade/Specs)				Material grade steel SUS304			
GENERAL DRAWING				Thickness of sheet 0.8mm			
2025R17P08-0030							
EAN (update when referencing is done)		3276007869897					
Format A3							
Scale 1:13							
Zhuhai Dali Kitchen & Bathroom Technology CO.,Ltd.		V13		30/10/2024		Drawing creation	
Supplier Reference		1254S		Date		Update description	
				ShuyunSong		YYY	
				Done by		Checked by	

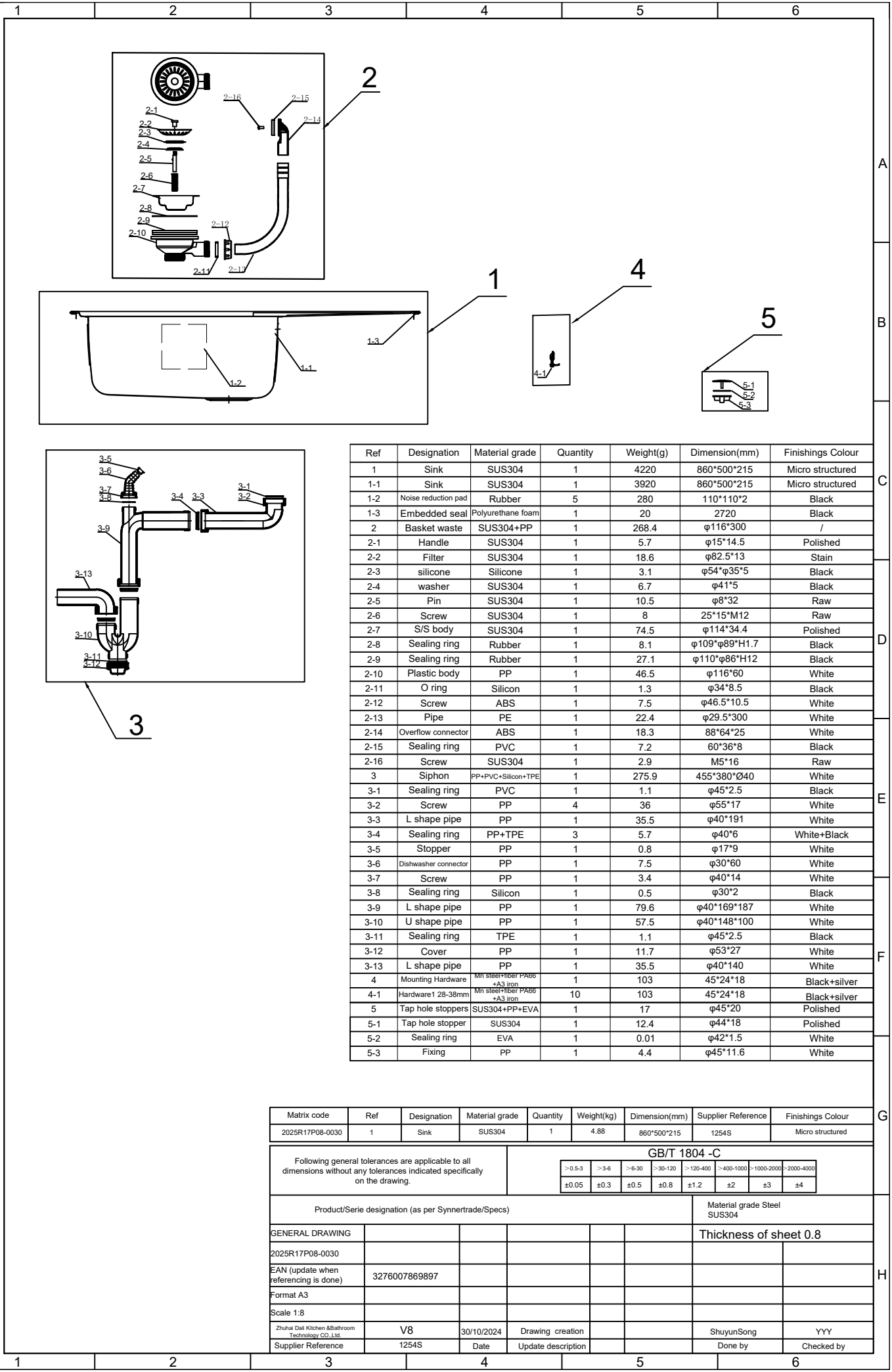

Ref	Designation	Material grade	Quantity	Weight(g)	Dimension(mm)	Finishings Colour
1	Sink	SUS304	1	4220	860*500*215	Micro structured
1-1	Sink	SUS304	1	3920	860*500*215	Micro structured
1-2	Noise reduction pad	Rubber	5	280	110*110*2	Black
1-3	Embedded seal	Polyurethane foam	1	20	2720	Black
2	Basket waste	SUS304+PP	1	268.4	φ116*300	/
2-1	Handle	SUS304	1	5.7	φ15*14.5	Polished
2-2	Filter	SUS304	1	18.6	φ82.5*13	Stain
2-3	silicone	Silicone	1	3.1	φ54*φ35*5	Black
2-4	washer	SUS304	1	6.7	φ41*5	Black
2-5	Pin	SUS304	1	10.5	φ8*32	Raw
2-6	Screw	SUS304	1	8	25*15*M12	Raw
2-7	S/S body	SUS304	1	74.5	φ114*34.4	Polished
2-8	Sealing ring	Rubber	1	8.1	φ109*φ89*H1.7	Black
2-9	Sealing ring	Rubber	1	27.1	φ110*φ86*H12	Black
2-10	Plastic body	PP	1	46.5	φ116*60	White
2-11	O ring	Silicon	1	1.3	φ34*8.5	Black
2-12	Screw	ABS	1	7.5	φ46.5*10.5	White
2-13	Pipe	PE	1	22.4	φ29.5*300	White
2-14	Overflow connector	ABS	1	18.3	88*64*25	White
2-15	Sealing ring	PVC	1	7.2	60*36*8	Black
2-16	Screw	SUS304	1	2.9	M5*16	Raw
3	Siphon	PP+PVC+Silicon+TPE	1	275.9	455*380*Ø40	White
3-1	Sealing ring	PVC	1	1.1	φ45*2.5	Black
3-2	Screw	PP	4	36	φ55*17	White
3-3	L shape pipe	PP	1	35.5	φ40*191	White
3-4	Sealing ring	PP+TPE	3	5.7	φ40*6	White+Black
3-5	Stopper	PP	1	0.8	φ17*9	White
3-6	Dishwasher connector	PP	1	7.5	φ30*60	White
3-7	Screw	PP	1	3.4	φ40*14	White
3-8	Sealing ring	Silicon	1	0.5	φ30*2	Black
3-9	L shape pipe	PP	1	79.6	φ40*169*187	White
3-10	U shape pipe	PP	1	57.5	φ40*148*100	White
3-11	Sealing ring	TPE	1	1.1	φ45*2.5	Black
3-12	Cover	PP	1	11.7	φ53*27	White
3-13	L shape pipe	PP	1	35.5	φ40*140	White
4	Mounting Hardware	Mn steel+fiber PABS +A3 iron	1	103	45*24*18	Black+silver
4-1	Hardware 1 28-38mm	Mn steel+fiber PABS +A3 iron	10	103	45*24*18	Black+silver
5	Tap hole stoppers	SUS304+PP+EVA	1	17	φ45*20	Polished
5-1	Tap hole stopper	SUS304	1	12.4	φ44*18	Polished
5-2	Sealing ring	EVA	1	0.01	φ42*1.5	White
5-3	Fixing	PP	1	4.4	φ45*11.6	White

Matrix code	Ref	Designation	Material grade	Quantity	Weight(kg)	Dimension(mm)	Supplier Reference	Finishings Colour
2025R17P08-0030	1	Sink	SUS304	1	4.88	860*500*215	1254S	Micro structured

GB/T 1804 - C							
>0.5-3	>3-6	>6-30	>30-120	>120-400	>400-1000	>1000-2000	>2000-4000
±0.05	±0.3	±0.5	±0.8	±1.2	±2	±3	±4

Product/Serie designation (as per Synnertrade/Specs)				Material grade Steel SUS304			
Thickness of sheet 0.8							
GENERAL DRAWING							
2025R17P08-0030							
EAN (update when referencing is done)	3276007869897						
Format A3							
Scale 1:8							
Zhuohai Dali Kitchen & Bathroom Technology CO., Ltd.	V8	30/10/2024	Drawing creation			ShuyunSong	YYY
Supplier Reference	1254S	Date	Update description			Done by	Checked by

