

EAN CODE : 3276007326444
3276007326413

FR Notice de Montage -
Utilisation - Entretien

ES Instrucciones de Montaje,
Utilización y Mantenimiento

PT Instruções de Montagem,
Utilização e Manutenção

IT Istruzioni per il Montaggio,
l'Uso e la Manutenzione

EL Εγχειρίδιο συναρμολόγησης,
χρήσης και συντήρησης

PL Instrukcja Montażu,
Użytkowania i Konserwacji

RU Руководство По Сборке
и Эксплуатации

KZ Жинау, пайдалану және
техникалық қызмет
көрсету нұсқаулығы

UA Керівництво По Збірці
і Експлуатації

RO Manual asamblare,
utilizare și întreținere

BR Instruções de Montagem,
Utilização e Manutenção

EN Assembly - Use -
Maintenance Manual

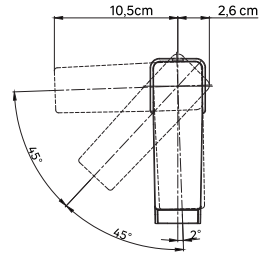
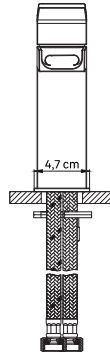
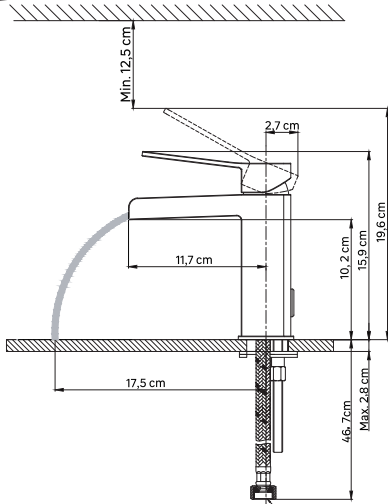

EU: F G 3/8" - 12/17mm
RU: F G 1/2" - 15/21mm
BR: F G 1/2" - 15/21mm

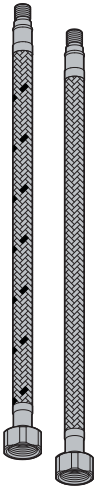

D

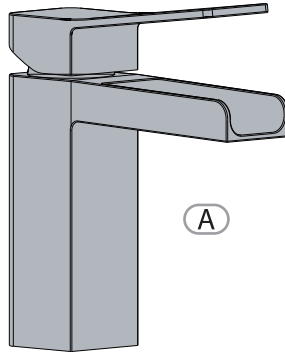

A

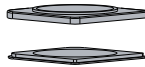

B

C



E



F



G

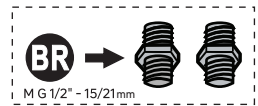

BR

M G 1/2" - 15/21mm





FR: Préparation / ES: Preparación / PT: Preparação / IT: Preparazione / EL: Προετοιμασία /
PL: Przygotowanie / RU: Подготовка / KZ: Дайындау / UA: Підготування / RO: Pregătire / BR: Preparação /
EN: Preparation



FR: Montage / ES: Montaje / PT: Montagem / IT: Montaggio / EL: Συναρμολόγηση /
PL: Montaż / RU: Сборка / KZ: Монтаждау / UA: Збірка / RO: Montaj / BR: Montagem /
EN: Assembly



FR: Utilisation eau chaude-eau froide/ ES: Utilización agua caliente-agua fría/ PT: Utilização água quente-água fria/
IT: Uso acqua calda-acqua fredda/ EL: Χρήση ζεστού-κρύου νερού/ PL: Użytkowanie zimnej wody-gorącej wody/
RU: использование горячей и холодной воды/ KZ: Суық және ыстық суды қолдану/
UA: використання гарячої - холодної води/ RO: Utilizare apă caldă-apă rece/ BR: Uso de água quente e fria/
EN: Using hot and cold water



FR: Changement de cartouche/ ES: Cambio de cartucho/ IT: Cambio cartuccia/ PT: Mudança de cartucho/
EL: Αλλαγή φυσιγγίου/ PL: Wymiana wkładu / RU: Смена картриджа/ KZ: Картриджи ауыстыру/
UA: Заміна картриджа/ RO: Schimbare cartuş/ BR: Substituição de cartucho / EN: Replacing the cartridge



FR: Changement de mousseur/ ES: Cambio de aireador/ PT: Mudança de arejador/ IT: Cambio rompigoetto/
EL: Αλλαγή αεράτορα / PL: Wymiana perlatora / RU: Смена аэратора/ KZ: Ауақанықтырғышты ауыстыру/
UA: Заміна аератора/ RO: Schimbare aerator/ BR: Substituição do aerador / EN: Replacing the aerator



FR: Changement de flexibles/ ES: Cambio de flexibles / PT: Mudança de flexíveis/ IT: Cambio flessibili/
EL: Αλλαγή λάστιχων/ PL: Wymiana wężyków instalacyjnych / RU: Смена гибкого шланга для смесителя/
UA: Заміна гнучкого шланга для змішувача/ KZ: Қоспалауышқа арналған иілгіш шлангты ауыстыру/
RO: Schimbare furtune flexibile/ BR: Substituição das mangueiras/ EN: Replacing the hoses

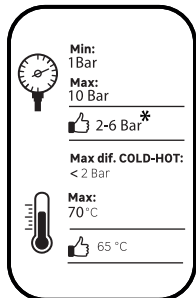

Min:
1 Bar

Max:
10 Bar

2-6 Bar*

Max dif. COLD-HOT:
< 2 Bar

Max:
70 °C

65 °C

FR:* Si la pression est supérieure à 5 bars, il est nécessaire de rajouter un réducteur de pression / ES:* Si la presión es superior a 5 bars, es necesario añadir un reductor de presión. / PT:* Se a pressão for superior a 5 bars, será necessário acrescentar um reductor de pressão / IT:* Se la pressione è superiore a 5 bar, bisogna aggiungere un riduttore di pressione / EL:* Εάν η πίεση υπερβαίνει τα 5 bars, είναι απαραίτητη η προσθήκη μειωτή πίεσης / PL:* Jeżeli ciśnienie jest wyższe niż 5 barów, należy dodać reductor ciśnienia / RU:* Если давление превышает 5 бар, необходимо установить редуктор давления / KZ:* Егер қысым 5 бардан асатын болса, қысым бәсеңдеткішін қосу қажет / UA:* Якщо тиск перевищує 5 бар, необхідно додати редуктор тиску / RO:* Dacă presiunea este mai mare de 5 bari, este necesar să adăugați un reductor de presiune / BR:* Se a pressão for superior a 5 bar, é necessário adicionar um reductor de pressão / EN:* If the pressure is over 5 bars, a pressure reducing valve must be added.



FR: Préparation / ES: Preparación / PT: Preparação / IT: Preparazione / EL: Προετοιμασία /
PL: Przygotowanie / RU: Подготовка / KZ: Дайындау / UA: Підготування / RO: Pregătire /
BR: Preparação / EN: Preparation

1

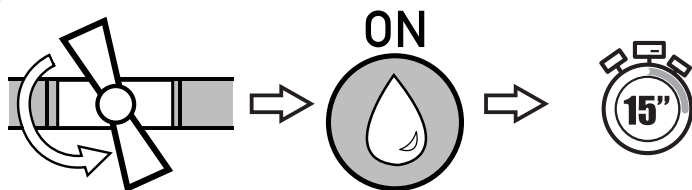

2

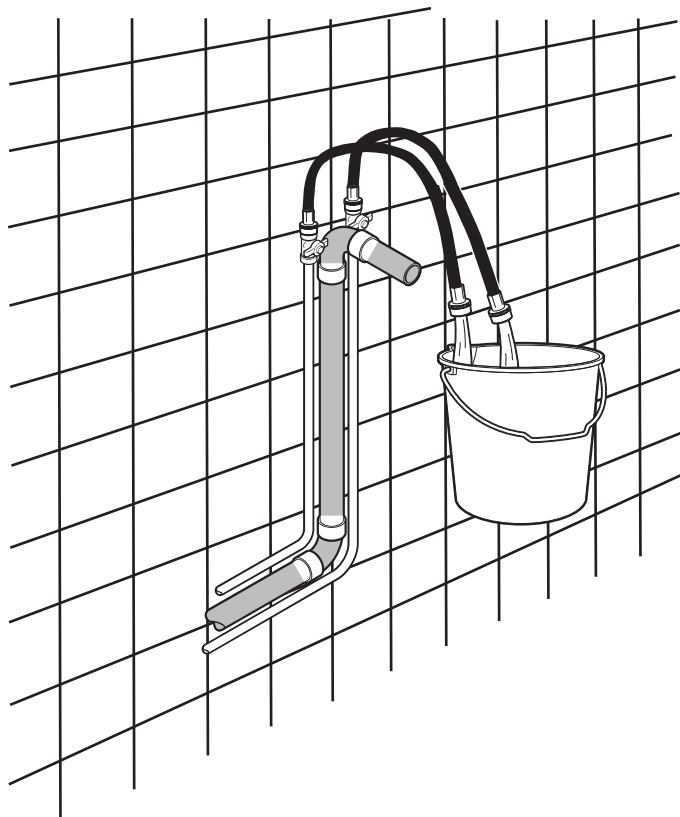

3

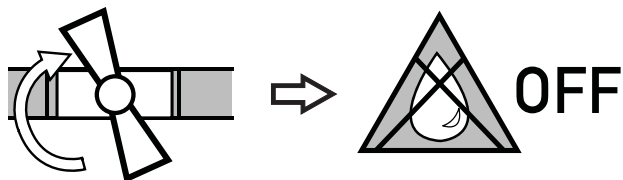



FR: Montage / ES: Montaje / PT: Montagem / IT: Montaggio / EL: Συναρμολόγηση /
PL: Montaż / RU: Сборка / KZ: Монтаждау / UA: Збірка / RO: Montaj / BR: Montagem /
EN: Assembly

1

1

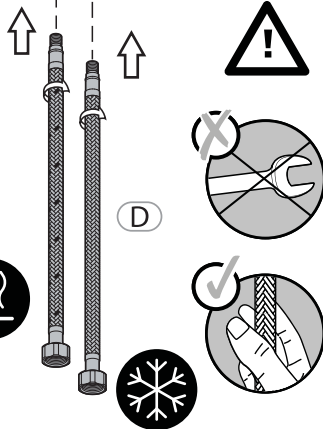
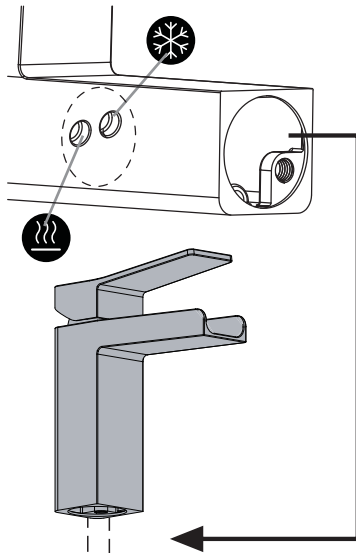

2

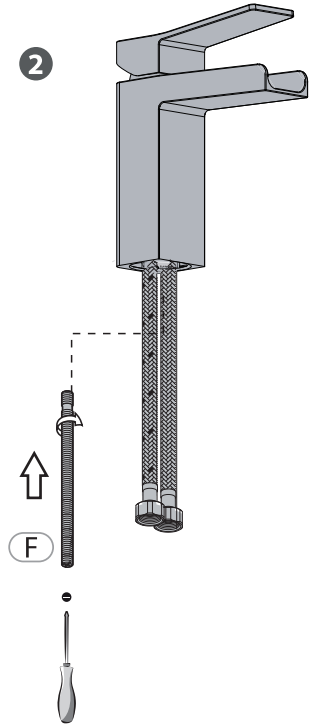

3

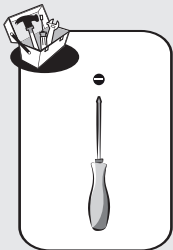
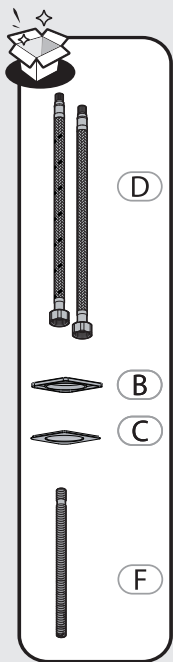
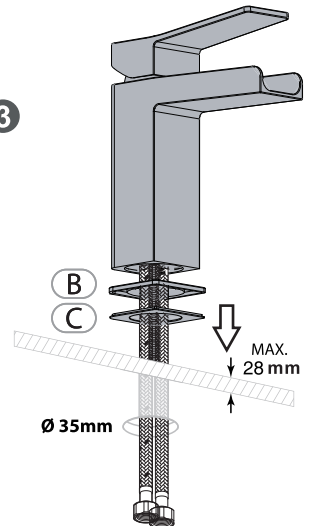

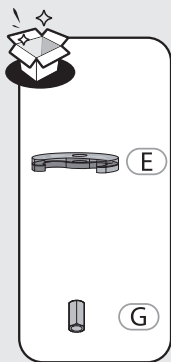

2

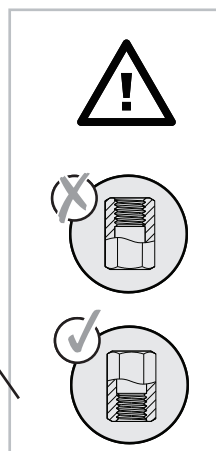
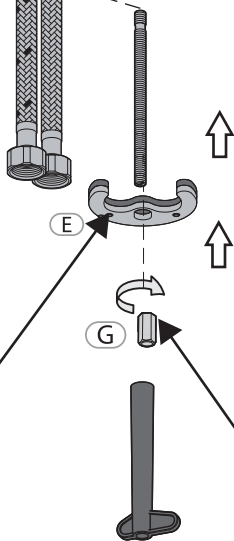
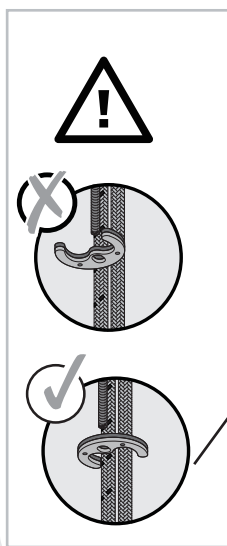
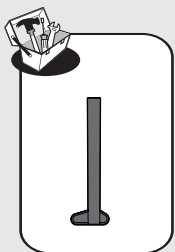
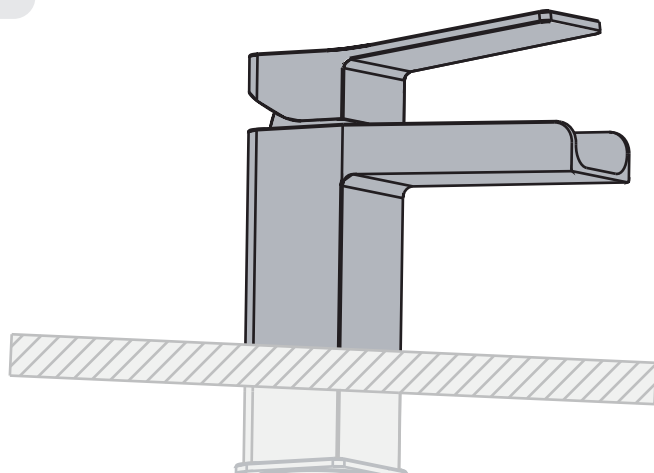

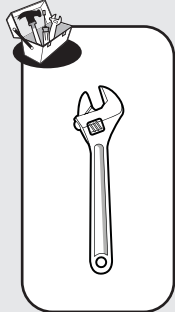

3

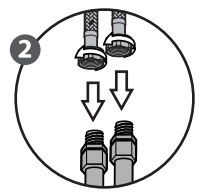
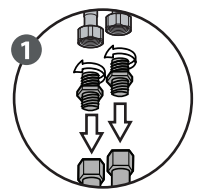
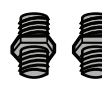
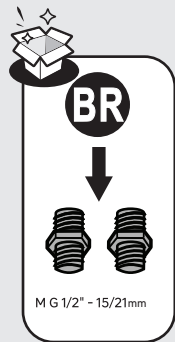
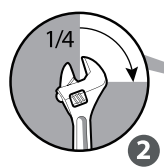
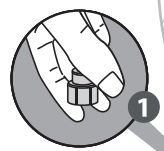
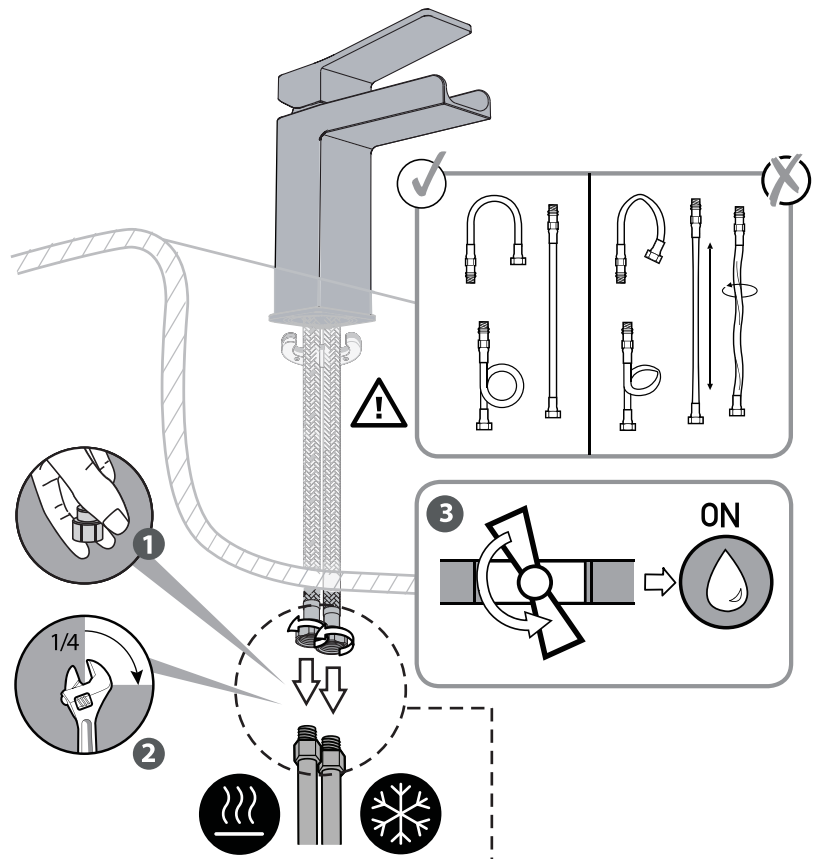



FR: Utilisation eau chaude-eau froide/ **ES:** Utilización agua caliente-agua fría/ **PT:** Utilização água quente-água fria/
IT: Uso acqua calda-acqua fredda/ **EL:** Χρήση ζεστού-κρύου νερού/ **PL:** Użytkowanie zimnej wody-gorącej wody/
RU: использование горячей и холодной воды/ **KZ:** Суық және ыстық суды қолдану/
UA: використання гарячої - холодної води/ **RO:** Utilizare apă caldă-apă rece/ **BR:** Uso de água quente e fria/
EN: Using hot and cold water

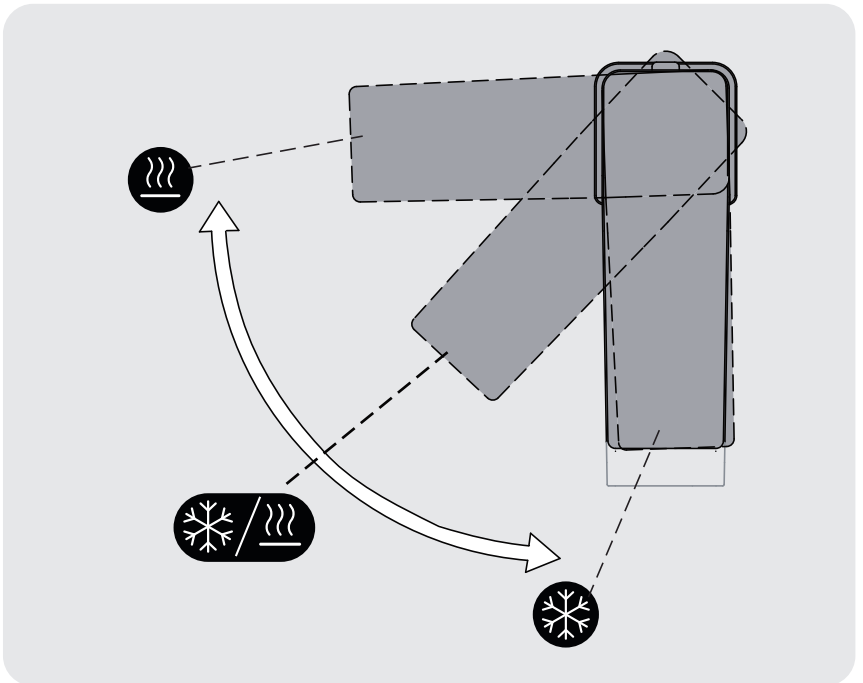
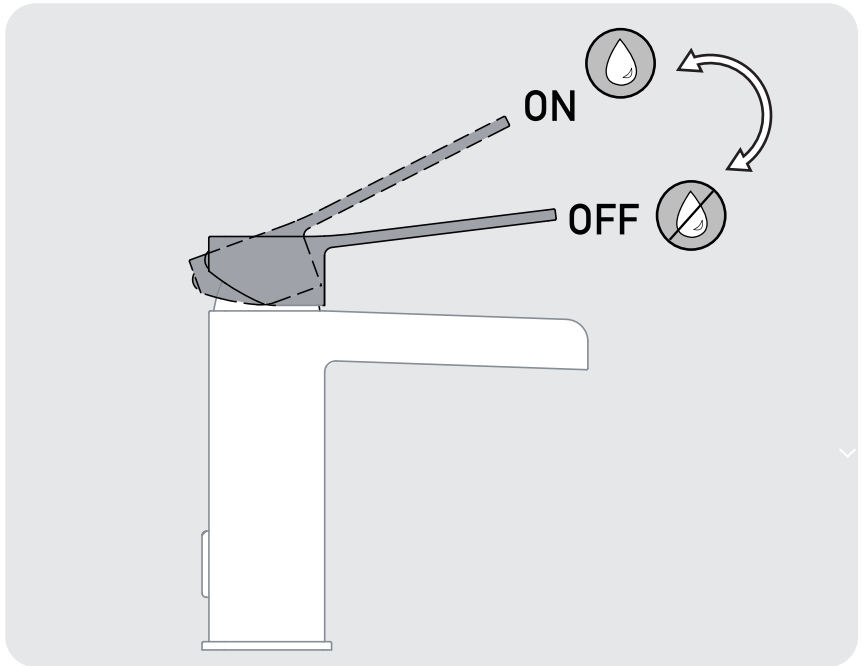

No.	Description	Code No.	QTY	Remark	Years warranty **
1	Screw Cover	MD7901-9	1	Colour body (2years)	10
2	Screw	BT-82	1		10
3	Handle	MD8001-2	1	Colour body (2years)	10
4	Cover	MD6001-4	1	Colour body (2years)	10
5	Compressing Nut	MD7001-3	1		10
6	Cartridge	TDS98SN25S0002	1		2
7	Cartridge Seat	MD7001-7	1		10
8	Body	MD8001-1	1	Colour body (2years)	10
9	Cover	MD8001-4	1	Colour body (2years)	10
10	Bottom Ring	MD8001-3	1	Colour body (2years)	10
11	Washer	MD8001-5	1		10
12	Washer	MD4001-11	1		10
13	Washer	MD4001-10	1		10
14	Screw Fitting	MD7001-8	1		10
15	Fitting Nut	MD4001-8	1		10
16	Flexible Hose-hot water-FG 3/8"-12/17mm	544112	1		10
17	Flexible Hose-cold water-FG 3/8"-12/17mm	544113	1		10
18	Flexible Hose-hot water-FG 1/2"-12/17mm	544116	1	RU + BR	10
19	Flexible Hose-cold water-FG 1/2"-12/17mm	544117	1	RU + BR	10
20	Wrench	MD7001-9	1		2
21	Adapter	MD4001A-14	2		10

*
FR: Garantie
ES: Garantía
PT: Garantia
IT: Garanzia
EL: Εγγύηση
PL: Gwarancja
RU: Гарантия
KZ: Кепілдік
UA: Гарантія
RO: garanție

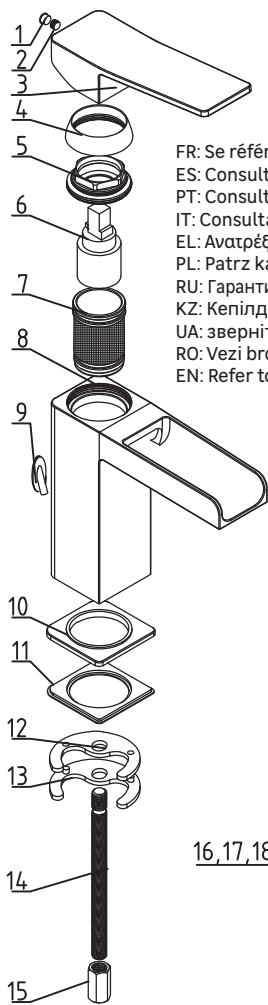

FR: Se référer au livret de garantie pour plus d'information
ES: Consulte el manual de garantía para más información
PT: Consulte o manual de garantia para mais informações
IT: Consultare il libretto di garanzia per ulteriori informazioni
EL: Ανατρέξτε στο φυλλάδιο της εγγύησης για περισσότερες πληροφορίες
PL: Patrz karcie gwarancyjnej, aby uzyskać więcej informacji
RU: Гарантийная книжка содержит дополнительную информацию по условиям гарантии на товар.
KZ: Кепілдік кітапшасында кепілдік жөніндегі қосымша ақпараттар бар.
UA: зверніться до гарантійного талону для отримання додаткової інформації
RO: Vezi broșura de garanție pentru mai multe informații
EN: Refer to the warranty booklet for more information

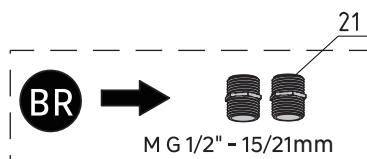
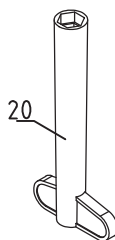
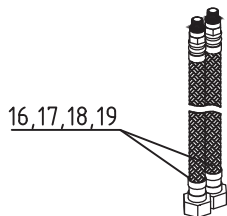



FR: Changement de cartouche/ ES: Cambio de cartucho/ IT: Cambio cartuccia/ PT: Mudança de cartucho/
EL: Αλλαγή φρεσγγίου/ PL: Wymiana wkładu / RU: Смена картриджа/ KZ: Картриджді ауыстыру/
UA: Заміна картриджа/ RO: Schimbare cartuş/ BR: Substituição de cartucho/ EN: Replacing the cartridge

1

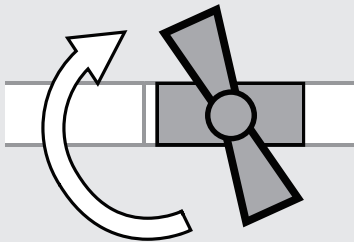

2

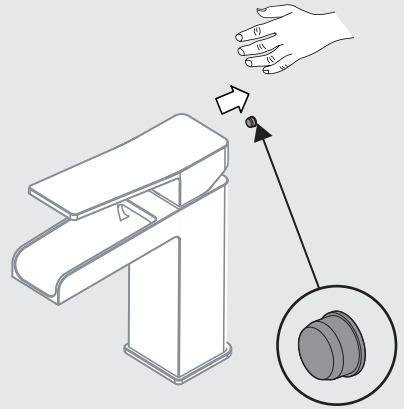

3

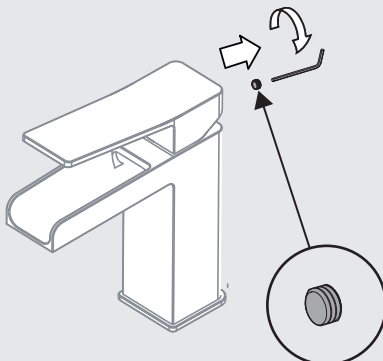

4

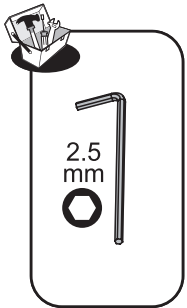
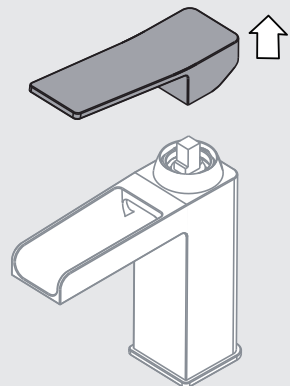

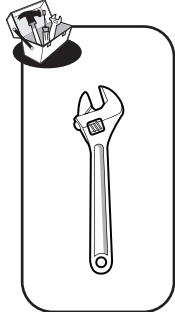

FR: Changement de cartouche/ ES: Cambio de cartucho/ IT: Cambio cartuccia/ PT: Mudança de cartucho/
EL: Αλλαγή φρεσγγύου/ PL: Wymiana wkładu/ RU: Смена картриджа/ KZ: Картриджді ауыстыру/
UA: Заміна картриджа/ RO: Schimbare cartuş/ BR: Substituição de cartucho/ EN: Replacing the cartridge

5

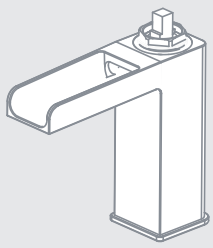
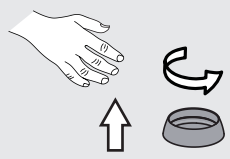

6

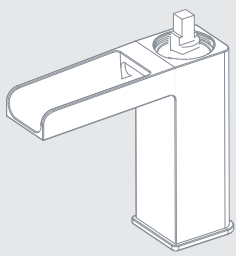
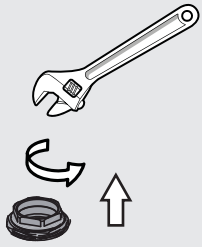

7

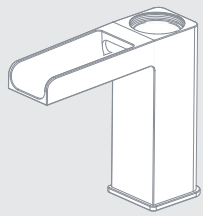
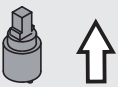

8

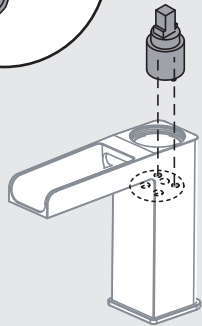
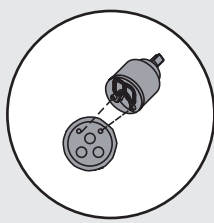

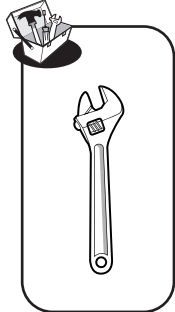

FR: Changement de cartouche/ ES: Cambio de cartucho/ IT: Cambio cartuccia/ PT: Mudança de cartucho/
EL: Αλλαγή φρεσγγύου/ PL: Wymiana wkładu / RU: Смена картриджа/ KZ: Картриджді ауыстыру/
UA: Заміна картриджа/ RO: Schimbare cartuş/ BR: Substituição de cartucho/ EN: Replacing the cartridge

9

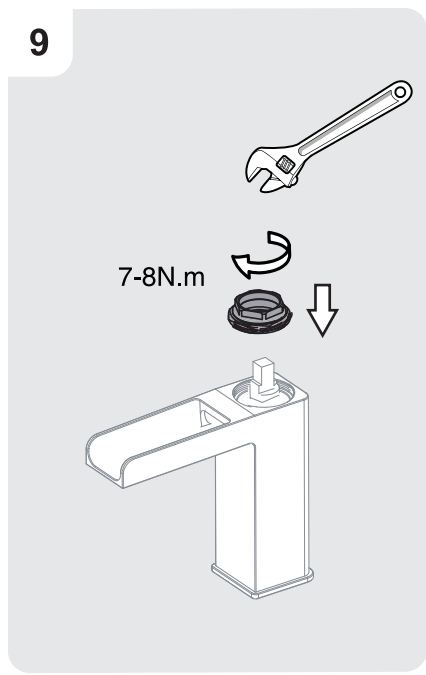

10

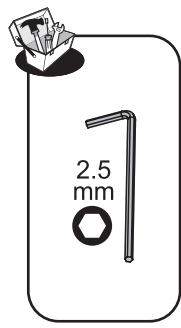

11

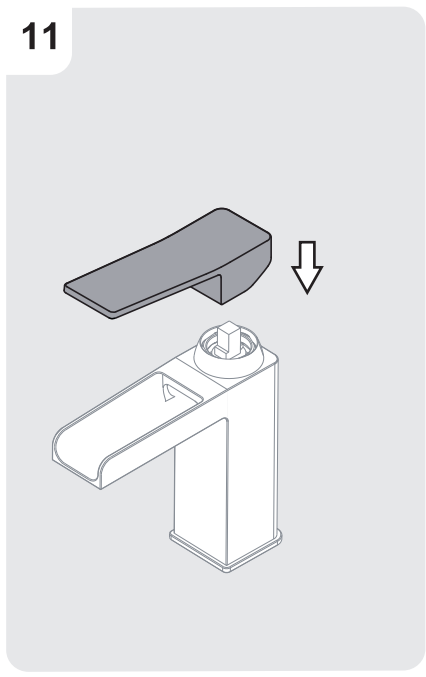

12

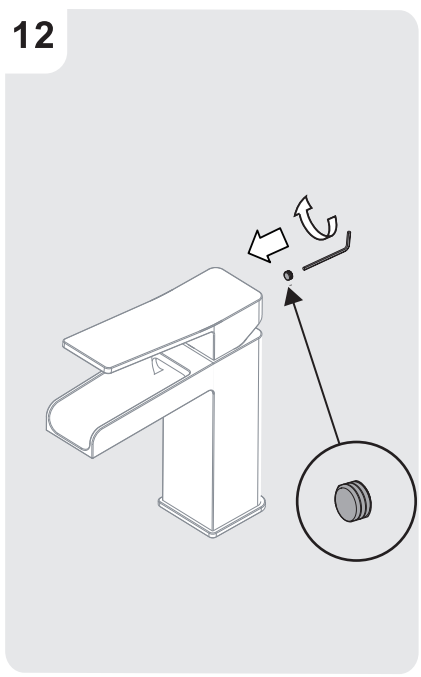



FR: Changement de cartouche/ **ES:** Cambio de cartucho/ **IT:** Cambio cartuccia/ **PT:** Mudança de cartucho/
EL: Αλλαγή φιλτράριου/ **PL:** Wymiana wkładu / **RU:** Смена картриджа/ **KZ:** Картриджді ауыстыру/
UA: Заміна картриджа/ **RO:** Schimbare cartuş/ **BR:** Substituição de cartucho/ **EN:** Replacing the cartridge

13

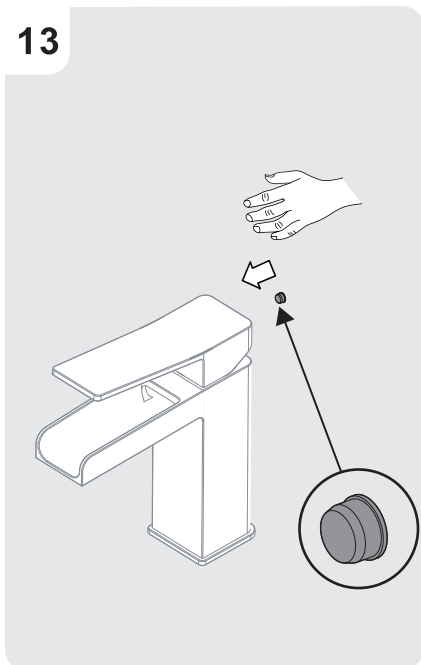

14

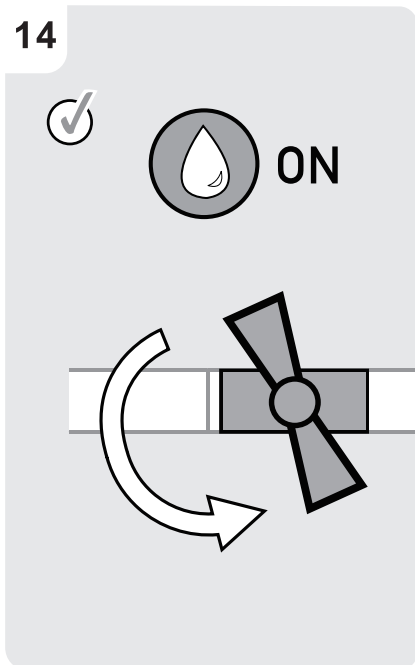

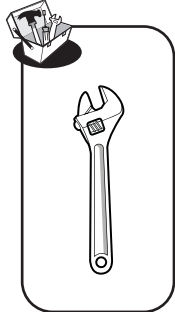

FR: Changement de flexibles/ **ES:** Cambio de flexibles / **PT:** Mudança de flexíveis/ **IT:** Cambio flessibili/
EL: Αλλαγή λάστιχων/ **PL:** Wymiana wężyków instalacyjnych / **RU:** Смена гибкого шланга для смесителя/
UA: Заміна гнучкого шланга для змішувача/ **KZ:** Қоспалауышқа арналған иілгіш шлангты ауыстыру/
RO: Schimbare furtune flexibile/ **BR:** Substituição das mangueiras/ **EN:** Replacing the hoses

1

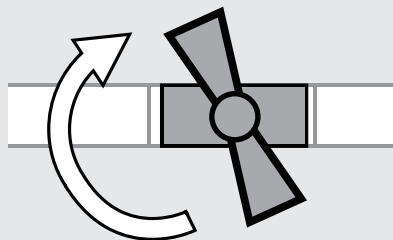

2

ON

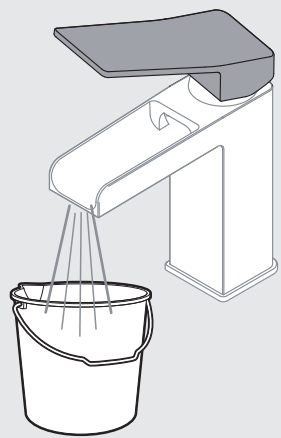

3

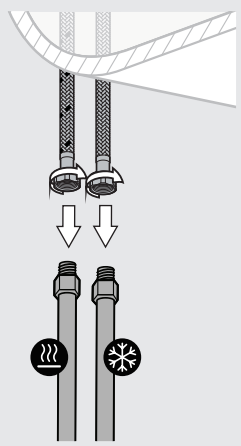

4

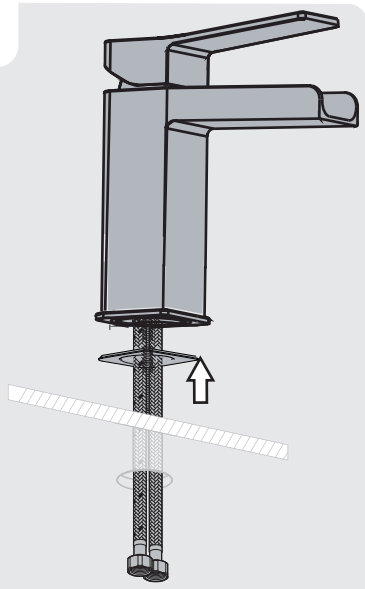

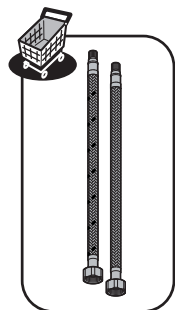
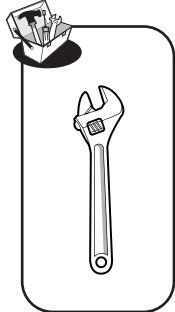

FR: Changement de flexibles/ **ES:** Cambio de flexibles / **PT:** Mudança de flexíveis/ **IT:** Cambio flessibili/
EL: Αλλαγή λάστιχων/ **PL:** Wymiana wężyków instalacyjnych / **RU:** Смена гибкого шланга для смесителя/
UA: Заміна гнучкого шланга для змішувача/ **KZ:** Қоспалауышқа арналған иілгіш шлангты ауыстыру/
RO: Schimbare furtune flexibile/ **BR:** Substituição das mangueiras/ **EN:** Replacing the hoses

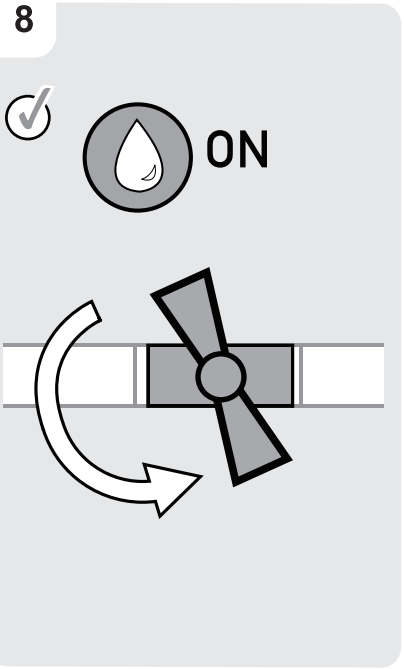
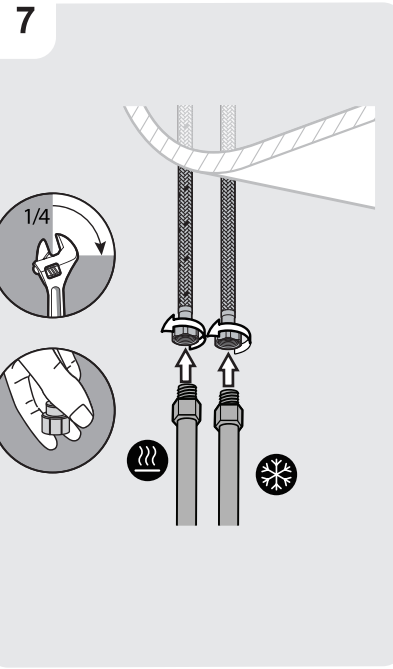
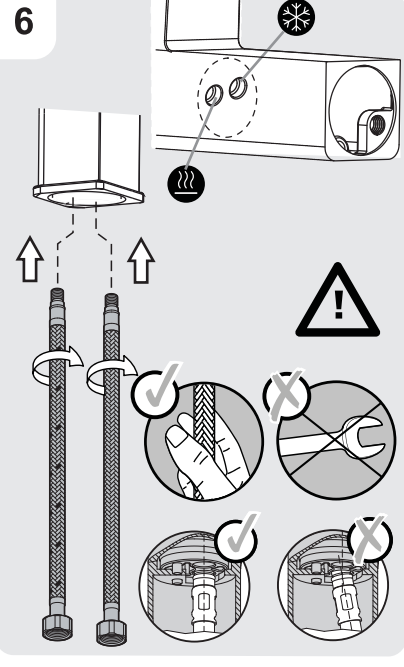
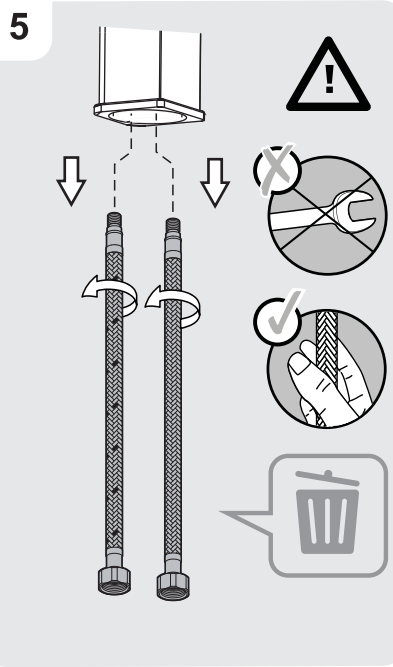



Eau claire / Agua limpia / Água limpa / Acqua pulita / Καθαρό νερό / Czysta woda / Чистая вода / Água limpa / Чиста вода / Ara curata / таза су / Clean water



Sans solvant / Sin disolvente / Sem solventes / Senza solventi / Χωρίς διαλυτικά / Bez rozpuszczalnika / Без растворителя / Sem solventes/ Без розчинника / Fara solvent / еріткішціз/ Solvent-free

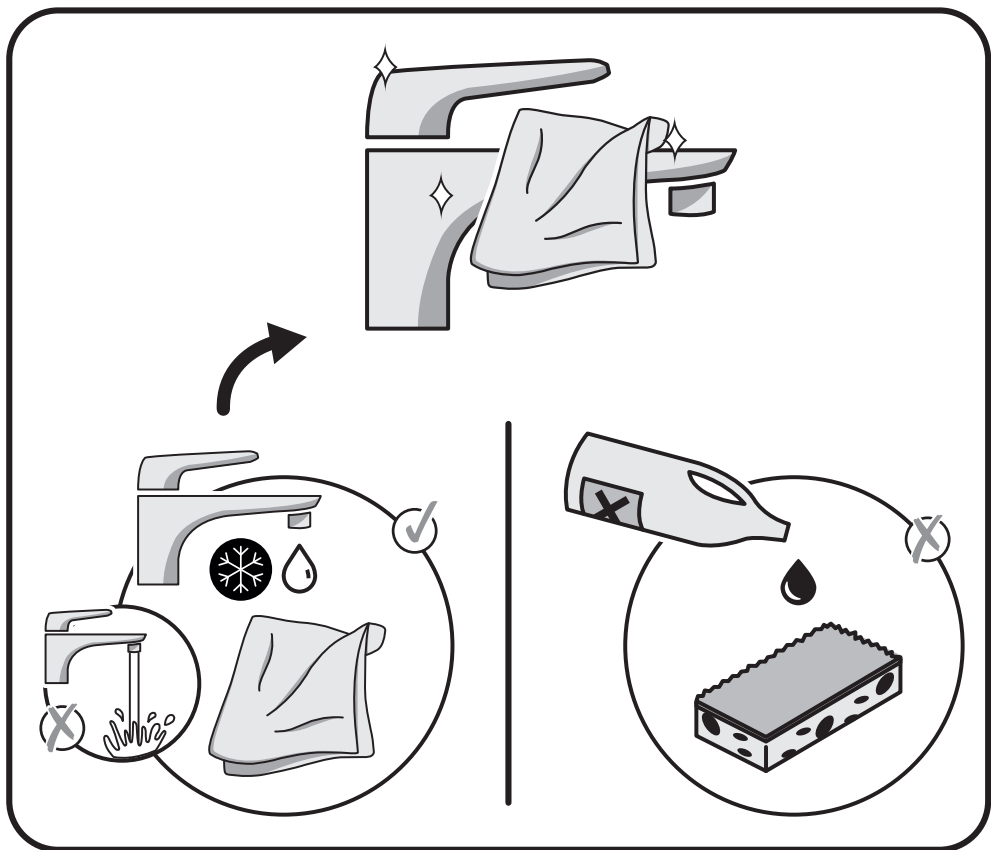

- FR** Pour une consommation d'eau adaptée, ce robinet est équipé d'un système à économie d'eau.
- ES** Este grifo cuenta con un sistema de ahorro de agua para un adecuado consumo de agua.
- PT** Para um consumo adequado de água, esta torneira está equipada com um sistema que economiza água.
- IT** Per un consumo d'acqua più adatto, questo rubinetto dispone di un sistema per economizzare l'acqua.
- EL** Για μια καλά ρυθμισμένη κατανάλωση νερού, αυτή η μπαταρία είναι εξοπλισμένη με ένα φίλτρο εξοικονόμησης νερού.
- PL** Aby zapewnić optymalne zużycie wody, kran ten jest wyposażony w system oszczędzający wodę.
- RU** Для правильного потребления воды этот кран оснащен водосберегающим система .
- KZ** Суды дұрыс тұтыну мақсатында бұл шүмек суды үнемдейтін жүйе жабдықталған.
- UA** Для правильного споживання води цей кран оснащений водозберігаючим система .
- RO** Pentru un consum adecvat de apă, acest robinet este echipat cu un sistem de economisire a apei.
- BR** Para um consumo adequado de água, essa torneira está equipada com um sistema para economia de água.
- EN** For an adequate water consumption, this tap is fitted with an eco system for water savings.



- FR** Attestation de conformité sanitaire
- ES** Certificado de conformidad sanitaria.
- PT** Atestado de conformidade sanitária.
- IT** certificato di conformità sanitaria.
- EL** Βεβαίωση υγειονομικής συμμόρφωσης.
- PL** Certyfikat zgodności sanitarnej.
- RU** Декларация о соответствии санитарным нормам
- KZ** Санитарлық талаптарға сәйкестік декларациясы
- UA** Декларація про відповідність санітарним нормам
- RO** Atestat de conformitate sanitară
- BR** Certificado de conformidade sanitária.
- EN** Declaration of sanitary conformity.



Made in China
Сделано в Китае
Қытайда жасалған



* Garantie 10 ans / 10 años de garantía / Garantia de 10 anos / Garanzia 10 Anni / Εγγύηση 10 ετών /
Gwarancja 10-letnia / Кепілдік мерзімі: 10 жыл / Гарантийный срок: 10 лет / Гарантія 10 років / Garantië 10 ani /
10-year guarantee

ADEO Services - 135 Rue Sadi Carnot - CS 00001
59790 RONCHIN - France

ТОВ "Леруа Мерлен Україна",
04201 Україна, м.Київ,
вул. Полярна 17А

Importado e distribuído por LEROY MERLIN CIA BRASILEIRA DE BRICOLAGEM - CNPJ 01.438.784/0001-05
Rua Domingas Galleteri Blotta, nº 315 - Jd Consórcio - São Paulo/SP - CEP 04455-360
CALM (Central de Atendimento Leroy Merlin): Capitais 4020-5376 - Demais Regiões 0800-0205376
IMAGENS ILUSTRATIVAS*

Imported by Adeo South Africa (PTY) LTD T/A Leroy Merlin,
Hosted in Leroy Merlin Fourways Store 35 Roos Street, Witkoppen Ext 97, Sandton, 2191 Johannesburg,
Gauteng, South Africa
Tel: +27 10 493 8000 Email: contact@leroymerlin.co.za

Импортер/Продавец/Организация, уполномоченная принимать претензии по качеству товара в
Рф: ООО «ЛЕРУА МЕРЛЕН ВОСТОК», 141031, Россия, Московская Обл., г. Мытищи, Осташковское шоссе, д.1

Импортер/Продавец/Организация, уполномоченная принимать претензии по качеству товара в
«Леруа Мерлен Қазақстан» ЖШС, Қазақстан Республикасы, 050000, Алматы қ., Қонаев көшесі, 77, «PARK VIEW» БО, 6-қабат, 07-кеңсе
Импортер/Продавец/Организация, принимающая претензии по качеству продукции в Республике Казахстан:
ТОО «Леруа Мерлен Казахстан», Республика Казахстан, 050000, г. Алматы, ул. Кунаева, 77, БЦ «PARK VIEW», 6 этаж, офис № 07

