

120-210 cm
210-360 cm

EAN : 3276000613459-3276000613497
MATRIX ID : 8101104

FR Manuel d'Instructions

ES Manual de Instrucciones

PT Manual de Instruções

IT Manuale di Istruzioni

EL Εγχειρίδιο Οδηγιών

PL Instrukcja Obsługi

UA Інструкція з Експлуатації

RO Manual de Instrucțiuni

EN Instructions Manual



***FR** Garantie 5 ans . ** Réparable.

***PT** Garantia 5 anos. **Reparável.

***EL** Εγγύηση 5 ετών. **Διορθώσιμος.

***UA** Гарантія 5 років. **Ремонтний.

***EN** Guarantee 5 years. **Repairable.

***ES** Garantía 5 años . ** Reparable.

***IT** Garanzia 5 anni. **Riparabile.

***PL** Gwarancja 5 lat. ** Naprawiany.

***RO** Garanție 5 ani . **Reparabil.



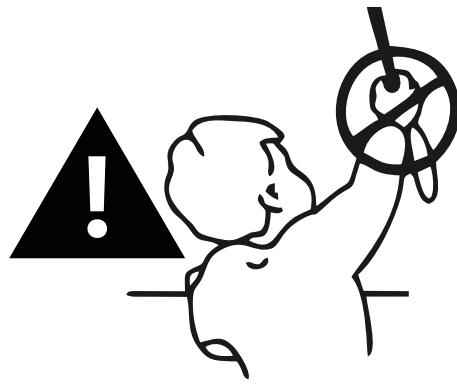

FR: ATTENTION

LES ENFANTS EN BAS ÂGES PEUVENT S'ÉTRANGLER AVEC LES BOUCLES FORMÉES PAR LES CORDES, CHAÎNETTES, SANGLES ET CORDONS INTERNES QUI PERMETTENT LA MANOEUVRE DU PRODUIT. POUR ÉVITER L'ÉTRANGLEMENT ET L'ENCHEVÊTREMENT, GARDEZ LES CORDONS HORS DE PORTÉE DES ENFANTS EN BAS ÂGES. LES CORDONS PEUVENT S'ENROULER AUTOUR DU COU D'UN ENFANT. ÉLOIGNEZ LES LITS D'ENFANTS ET LE MOBILIER DES CORDONS ACTIONNANT LES STORES INTÉRIEURS. NE LIEZ PAS LES CORDONS ENSEMBLE. ASSUREZ-VOUS QUE LES CORDONS NE VRILLENT PAS ET NE FORMENT PAS DE BOUCLE.

ES: ATENCIÓN

LOS NIÑOS PEQUEÑOS PUEDEN ESTRANGULARSE CON LOS BUCLES FORMADOS POR LAS CUERDAS, CADENETAS, CORREAS Y CORDONES INTERNOS QUE PERMITEN MANIOBRAR EL PRODUCTO. PARA EVITAR LA ESTRANGULACIÓN Y EL ENREDO, MANTENGA LOS CORDONES FUERA DEL ALCANCE DE LOS NIÑOS PEQUEÑOS, YA QUE SE LES PODRIAN ENROLLAR ALREDEDOR DEL CUELLO. COLOQUE LAS CAMAS DE LOS NIÑOS Y LOS MUEBLES LEJOS DE LOS CORDONES QUE ACCIONAN LOS ESTORES INTERIORES. NO ATE LOS CORDONES ENTRE SÍ. ASEGÚRESE DE QUE NO SE RETUERZAN Y NO FORMEN NINGÚN BUCLE.

PT: ATENÇÃO

AS CRIANÇAS PEQUENAS PODEM ESTRANGULAR-SE COM OS LAÇOS FORMADOS PELOS CORDAS, CORRENTES, CINTAS E CORDÕES USADOS PARA OPERAR O PRODUTO. PARA EVITAR O RISCO DE ESTRANGULAMENTO E EMARANHAMENTO, MANTENHA OS CORDÕES FORA DO ALCANCE DAS CRIANÇAS PEQUENAS. OS CORDÕES PODEM ENROLAR-SE EM VOLTA DO PESCOÇO DE UMA CRIANÇA. AFASTÉ AS CAMAS DAS CRIANÇAS E OS MÓVEIS DOS CORDÕES UTILIZADOS PARA OPERAR OS ESTORES INTERIORES. NÃO AMARRE OS CORDÕES UNS AOS OUTROS. CERTIFIQUE-SE DE QUE OS CORDÕES NÃO ESTÃO TORCIDOS NEM FORMAM LAÇOS.

IT: ATTENZIONE

I CORDONI, LE CATENELLE, LE CINGHIE E LE CORDE INTERNE PER L'APERTURA / CHIUSURA DEL PRODOTTO POTREBBERO FORMARE DEI CAPPI: RISCHIO DI STRANGOLAMENTO PER I BAMBINI PICCOLI. PER EVITARE RISCHI DI STRANGOLAMENTO E PER PREVENIRE L'AGGROVIGLIAMENTO DELLE CORDE, TENERLE FUORI DALLA PORTATA DEI BAMBINI PICCOLI. LE CORDE POTREBBERO AVVOLGERSI ATTORNO AL COLLO DEI BAMBINI. POSIZIONARE I LETTI DEI BAMBINI E I MOBILI LONTANO DALLE CORDE PER L'APERTURA/CHIUSURA DELLE TENDE INTERNE. NON LEGARE INSIEME LE CORDE. ASSICURARSI CHE LE CORDE NON SI ATTORCIGLINO E NON FORMINO CAPPI.

EL: ΠΡΟΣΟΧΗ

ΤΑ ΣΧΟΙΝΙΑ, ΟΙ ΑΛΥΣΙΔΕΣ ΚΑΙ ΟΙ ΙΜΑΝΤΕΣ, ΚΑΘΩΣ ΚΑΙ ΤΑ ΕΣΩΤΕΡΙΚΑ ΚΟΡΔΟΝΙΑ ΓΙΑ ΤΟ ΧΕΙΡΙΣΜΟ ΤΟΥ ΠΡΟΪΟΝΤΟΣ ΜΠΟΡΟΥΝ ΝΑ ΣΧΗΜΑΤΙΣΟΥΝ ΘΗΛΙΕΣ ΑΠΟ ΤΙΣ ΟΠΟΙΕΣ ΤΑ ΜΙΚΡΑ ΠΑΙΔΙΑ ΔΙΑΤΡΕΧΟΥΝ ΚΙΝΔΥΝΟ ΣΤΡΑΓΓΑΛΙΣΜΟΥ. ΓΙΑ ΝΑ ΑΠΟΦΥΓΕΤΕ ΤΟΝ ΚΙΝΔΥΝΟ ΣΤΡΑΓΓΑΛΙΣΜΟΥ ΚΑΙ ΕΜΠΛΟΚΗΣ, ΕΧΕΤΕ ΤΑ ΚΟΡΔΟΝΙΑ ΜΑΚΡΙΑ ΑΠΟ ΜΙΚΡΑ ΠΑΙΔΙΑ. ΤΑ ΚΟΡΔΟΝΙΑ ΜΠΟΡΟΥΝ ΝΑ ΤΥΛΙΧΤΟΥΝ ΓΥΡΩ ΑΠΟ ΤΟ ΛΑΙΜΟ ΕΝΟΣ ΠΑΙΔΙΟΥ. ΑΠΟΜΑΚΡΥΝΕΤΕ ΤΑ ΚΡΕΒΑΤΙΑ ΤΩΝ ΠΑΙΔΙΩΝ ΚΑΙ ΤΑ ΕΠΙΠΛΑ ΑΠΟ ΤΑ ΚΟΡΔΟΝΙΑ ΓΙΑ ΤΑ ΕΣΩΤΕΡΙΚΑ ΣΤΟΡΙΑ. ΜΗ ΔΕΝΕΤΕ ΜΕΤΑΞΥ ΤΟΥΣ ΤΑ ΚΟΡΔΟΝΙΑ. ΒΕΒΑΙΩΘΕΙΤΕ ΟΤΙ ΤΑ ΚΟΡΔΟΝΙΑ ΔΕΝ ΣΥΣΤΡΕΦΟΝΤΑΙ ΚΑΙ ΟΤΙ ΔΕΝ ΣΧΗΜΑΤΙΖΟΥΝ ΘΗΛΙΑ.

PL: UWAGA

MŁODSZE DZIECI MOGĄ SIĘ UDUSIĆ W WYNIKU ZAPŁĄTANIA W PĘTLE POWSTAŁE ZE SZNURKÓW, ŁAŃCUSZKÓW, PASKÓW I LINEK, SŁUŻĄCYCH DO PORUSZANIA PRODUKTEM. ABY ZAPOBIEC UDUSZENIU I ZAPŁĄTANIU, LINKI NALEŻY UMIEŚCIĆ W MIEJSCU NIEDOSTĘPNYM DLA MŁODSZYCH DZIECI. LINKI MOGĄ OWIŃAĆ SIĘ WOKÓŁ SZYI DZIECKA. ŁÓŻECZKO DZIECIĘCE ORAZ SPRZĘT NALEŻY STAWIAĆ W BEZPIECZNEJ ODLEGŁOŚCI OD LINEK STERUJĄCYCH ROLETAMI WEWNĘTRZNYMI. NIE ŁĄCZYĆ LINEK ZE SOBĄ. UPEWNIĆ SIĘ, CZY LINKI NIE SĄ SKRĘCONE I NIE TWORZĄ PĘTLI.

UA: УВАГА

МАЛІ ДІТИ МОЖУТЬ ЗАДУШИТИ СЕБЕ ПЕТЛЯМИ, УТВОРЕНИМИ МОТУЗКАМИ, ЛАНЦЮГАМИ, РЕМЕНЯМИ ТА ВНУТРІШНІМИ ШНУРАМИ, ЯКІ ДОЗВОЛЯЮТЬ КЕРУВАТИ ВИРОБОМ. ЩОБ УНИКНУТИ ДУШЕННЯ ТА СПЛУТУВАННЯ, ЗБЕРІГАЙТЕ ШНУР В МАЛЕНЬКОМУ ДІТЕЙ. ШИЮ ДИТИНИ МОЖНА ОБМОТИТИ ШНУР. ТРИМАЙТЕ ДИТЯЧІ ЛІЖКА ТА МЕБЛІ ПОДАЛЕКО ВІД ШНУРІВ, ЩО ПРИВОДЯТЬ ВНУТРІШНІ ЖАЛЮЗИ. НЕ ЗВ'ЯЗУЙТЕ ШНУРИ ОДНОМ. ПЕРЕКОНАЙТЕСЯ, ЩОБ ШНУРИ НЕ СКРУЧУВАЛИСЯ АБО НЕ УТВОРИЛИ ПЕТЕЛЬ.

RO: ATENȚIE

COPILII MICI SE POT STRANGULA CU BUCLELE FORMATE DE ȘNURURILE, LANȚURILE, CHINGILE ȘI CORDOANELE ÎNTERIOARE OPEREAZĂ PRODUSUL. PENTRU A EVITA STRANGULAREA SAU PRINDEREA, NU LĂSAȚI ȘNURURILE LA ÎNDEMÂNA COPILILOR MICI. ACESTEA SE POT ÎNFĂȘURA ÎN JURUL GÂTULUI COPILULUI. MUTA-ȚI PĂTUȚURILE COPILOR ȘI MOBILA DEPARTE DE ȘNURURILE JALUZELELOR. NU LEGAȚI ȘNURURILE ÎNTRE ELE. ASIGURAȚI-VĂ CĂ ACESTEA NU SE RĂSUCESC ȘI NU AJUNG SĂ FORMEZE BUCLE.

EN: WARNING

YOUNG CHILDREN CAN BE STRAGLED BY LOOPS IN PULL CORDS, CHAINS, TAPES AND INNER CORDS THAT OPERATE THE PRODUCT. TO AVOID STRAGULTION AND ENTANGLEMENT, KEEP CORDS OUT OF THE REACH OF YOUNG CHILDREN. CORDS MAY BECOME WRAPPED AROUND A CHILD'S NECK. MOVE BEDS, COTS AND FURNITURE AWAY FROM WINDOW COVERING CORDS. DO NOT TIE CORDS TOGETHER. MAKE SURE CORDS DO NOT TWIST AND CREATE A LOOP.

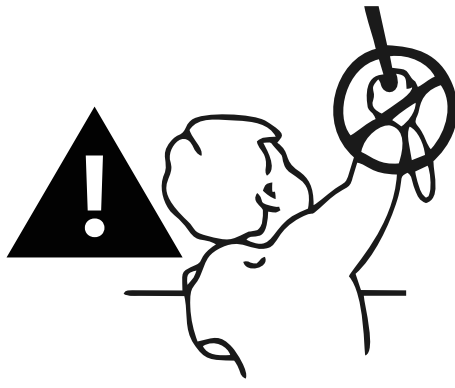

FR: ATTENTION

UNE MODIFICATION DE CONCEPTION OU DE CONFIGURATION DE L'ÉQUIPEMENT SANS CONSULTATION PRÉALABLE DU FABRICANT OU DE SON REPRÉSENTANT ATTITRÉ RISQUE D'ENTRAÎNER UNE SITUATION DANGEREUSE.

LORSQU'IL EST UTILISÉ COMME PRÉVU, CE PRODUIT NE NÉCESSITE PAS D'ENTRETIEN OU DE PIÈCES DE RECHANGE. VEUILLEZ LIRE ET SUIVRE ATTENTIVEMENT LES INSTRUCTIONS D'INSTALLATION. LE RAIL EST DESTINÉ À UN USAGE INTERNE. VOUS POUVEZ ESSUYER DOUCEMENT AVEC UN CHIFFON LÉGÈREMENT HUMIDE SANS FROTTER. LE RAIL DOIT ÊTRE CONTRÔLÉ RÉGULIÈREMENT POUR S'ASSURER QU'IL EST BIEN FIXÉ ET OPÉRATIONNEL, CONFORMÉMENT AUX INSTRUCTIONS ET POUR DÉTECTER TOUT DOMMAGE ÉVENTUEL. LA LIBÉRATION DE PETITES PIÈCES POURRAIT PROVOQUER L'ASPHYXIE INTERNE DE L'ENFANT. LE TENDEUR DE CHAÎNE UTILISÉ DOIT ÊTRE FIXÉ À HAUTEUR > 150CM DU SOL. LORS DU MONTAGE, PORTEZ UNE ATTENTION PARTICULIÈRE À LA TENSION CORRECTE DE LA CHAÎNE. L'INSTALLATION DU RAIL INTÉRIEUR PEUT ÊTRE EFFECTUÉ PAR DES PERSONNES NON PROFESSIONNELLES APRÈS AVOIR LU ATTENTIVEMENT LES INSTRUCTIONS DE MONTAGE ET LES AVERTISSEMENTS.

LES ENFANTS PEUVENT S'ÉTRANGLER SI CE SYSTÈME DE SÉCURITÉ N'EST PAS INSTALLÉ.

TOUJOURS UTILISER CE SYSTÈME POUR MAINTENIR LES CORDONS OU CHAÎNETTES HORS DE PORTÉE DES ENFANTS.

LES ENFANTS PEUVENT S'ÉTRANGLER SI CE SYSTÈME DE SÉCURITÉ N'EST PAS INSTALLÉ ET AJUSTÉ.

LIRE AVEC ATTENTION LES INSTRUCTIONS ET EFFECTUER L'INSTALLATION CONFORMÉMENT À CES DERNIÈRES



Pièces / Piezas / Partes / Parti di ricambio / Ανταλλακτικά / Części / Запчасти/деталь/Бөлмелер/Детали/деталей / Piese / Peças / חדרים / غرف / Parts

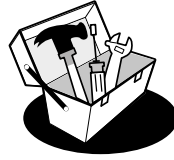

Outils/Herramientas/Ferramentas / Strumenti / Εργαλεία / Narzędzia / Инструменты / Құралдар / Инструменти / Instrumente / Ferramentas/ כלים / أدوات/Tools



Achat supplémentaire / Compra adicional / Compra adicional / Acquisto supplementare / Πρόσθετη αγορά / Dodatkowy zakup / Дополнительная покупка / Дополнительная покупка / Achiziție suplimentară / Compra adicional / רכישה נוספת / شراء إضافي / Additional purchase



Préparation / Preparación / Preparação / Preparazione / Προϊομοσύνη / Przygotowanie / Подготовка / Дайындалуу / Підготування / Pregătire / Preparação / הרפנה / حشد / Preparation



Montage / Montaje / Assembleia / Montaggio / Συναρμολόγηση / Montaż / Сборка / Монтаж / Збірка / Asamblarea / Assembléia / הרפנה / حشد / Assembly

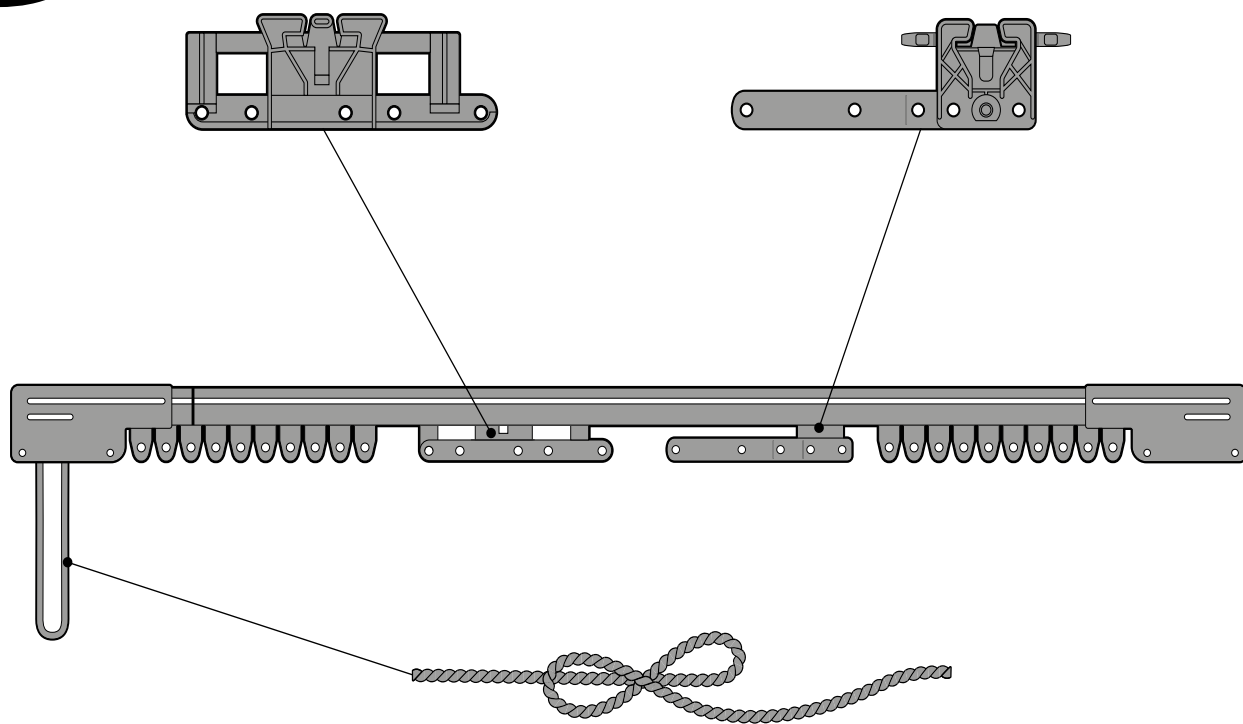

120 - 210 cm

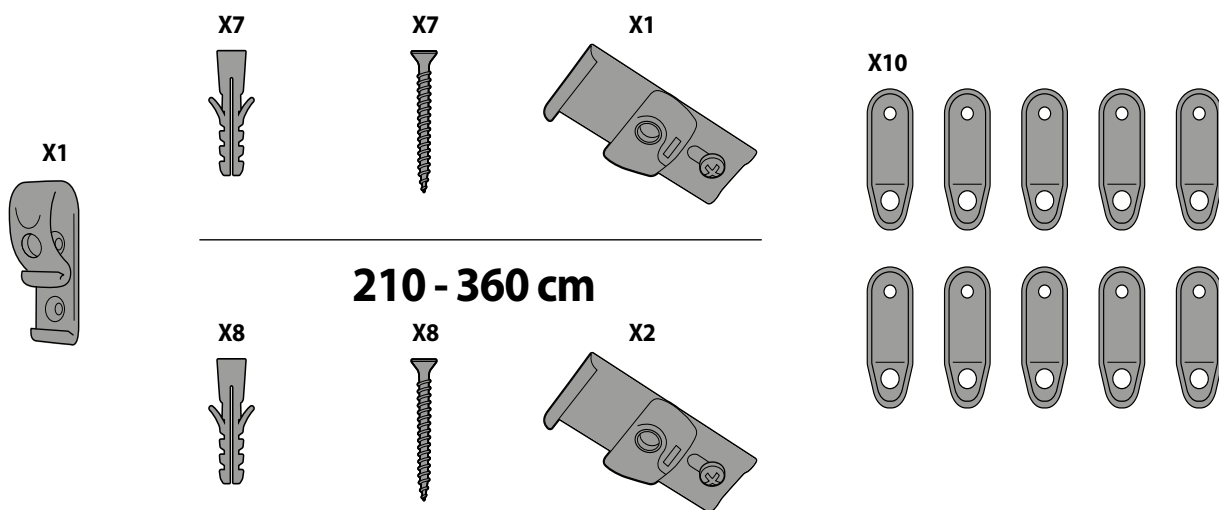

210 - 360 cm

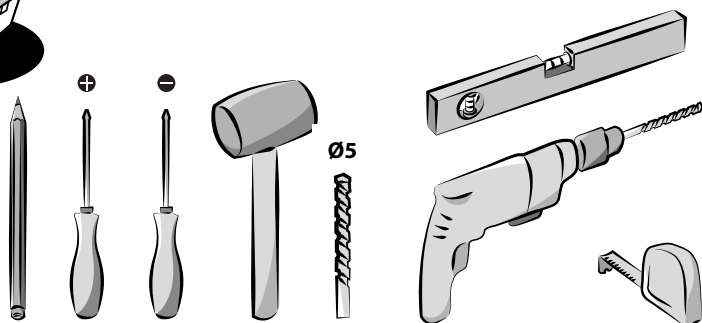
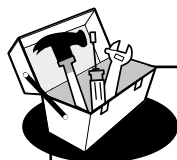

120 - 210 cm

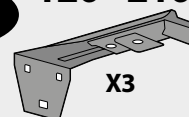

X3

210 - 360 cm

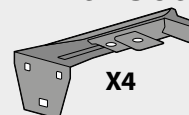

X4



1

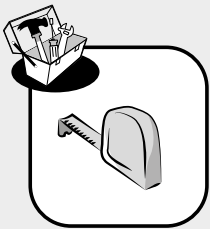
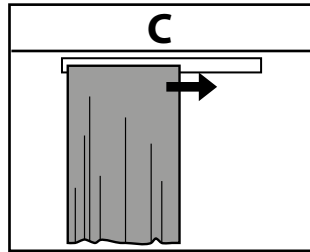
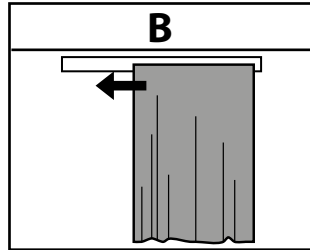
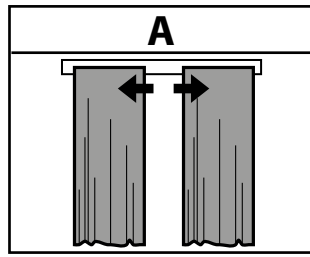

2

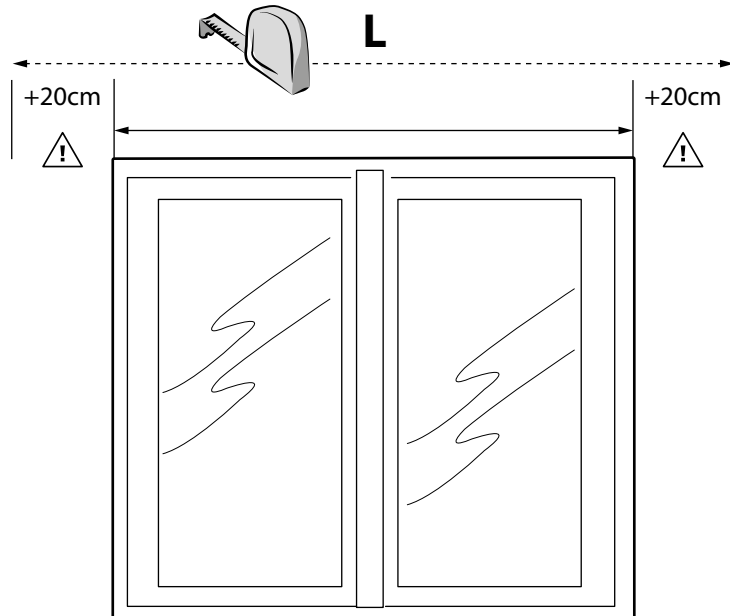

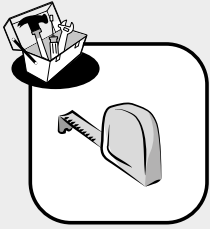

1A

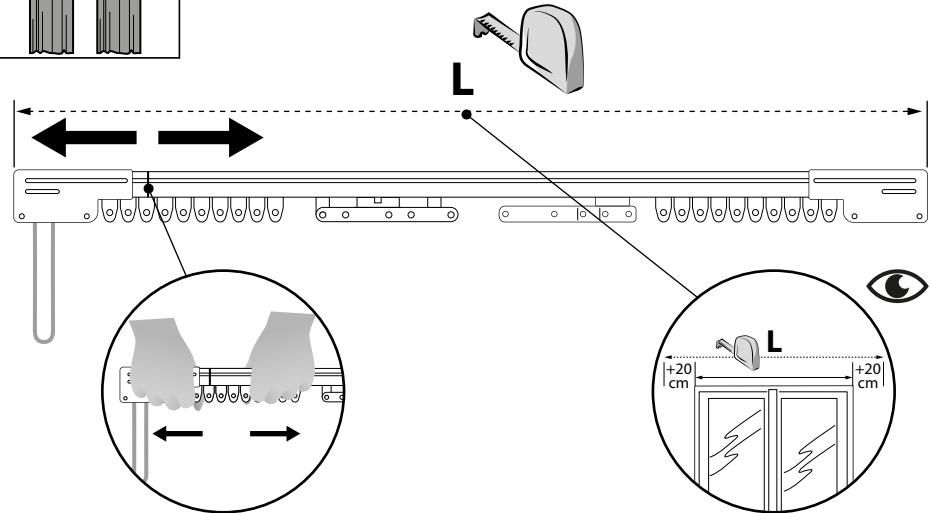
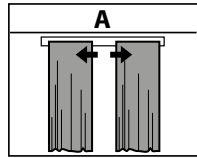

2A

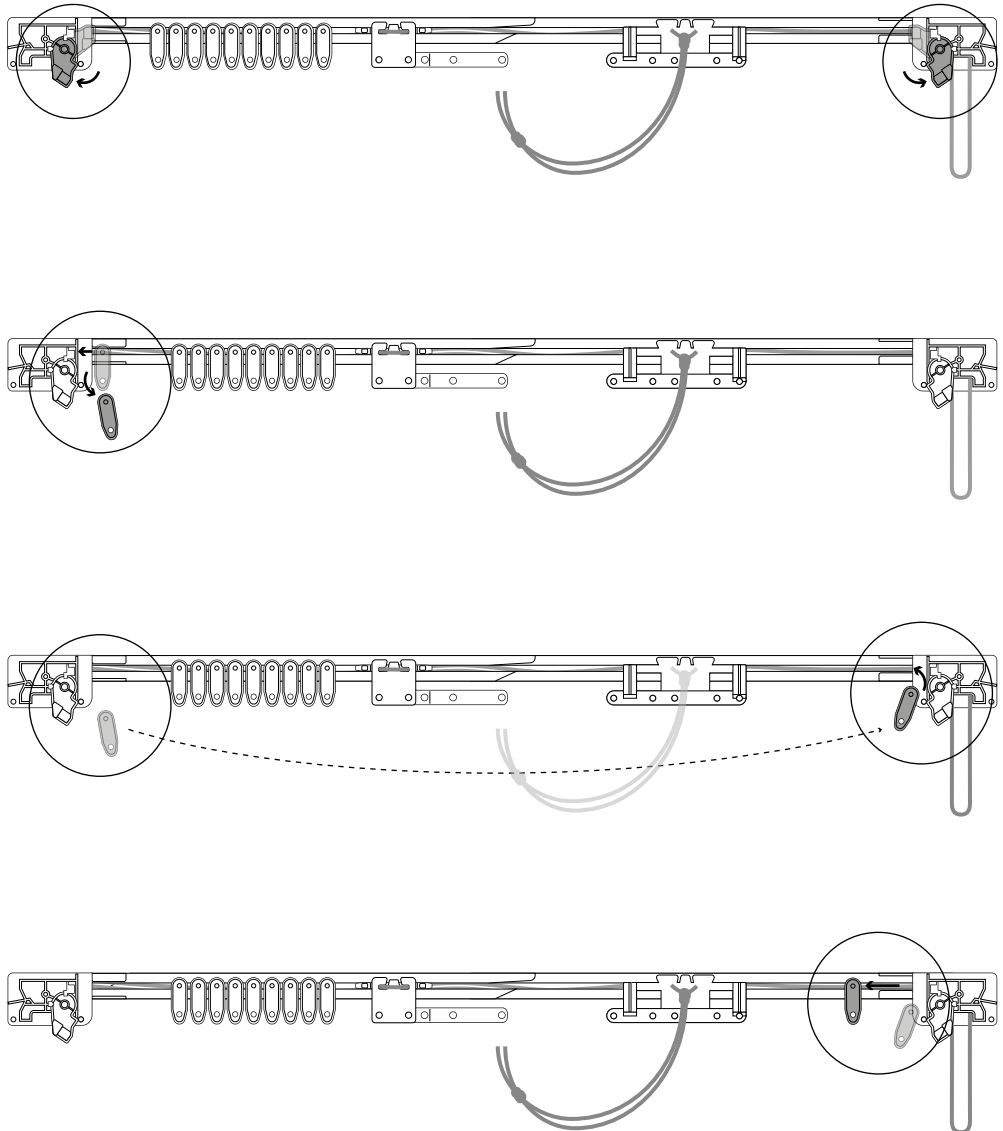



3A

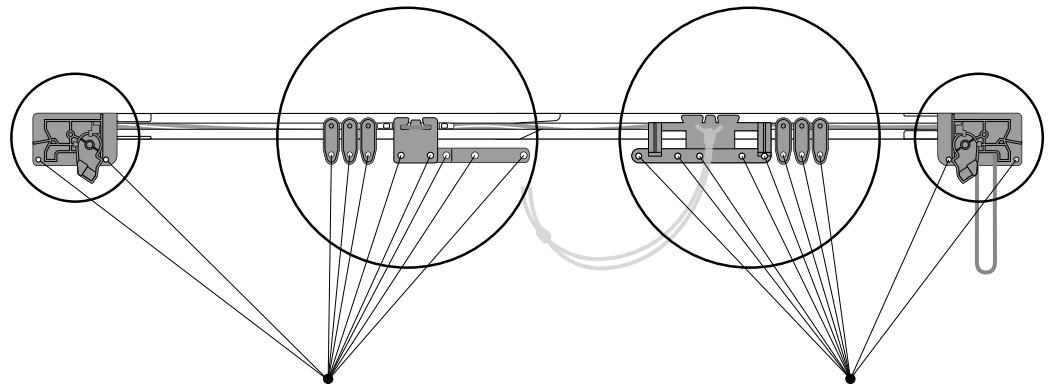

=n1

=n2

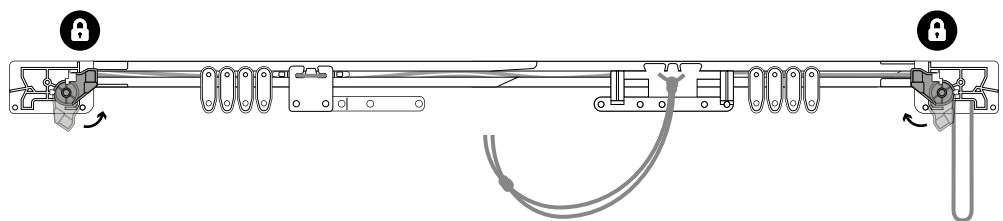
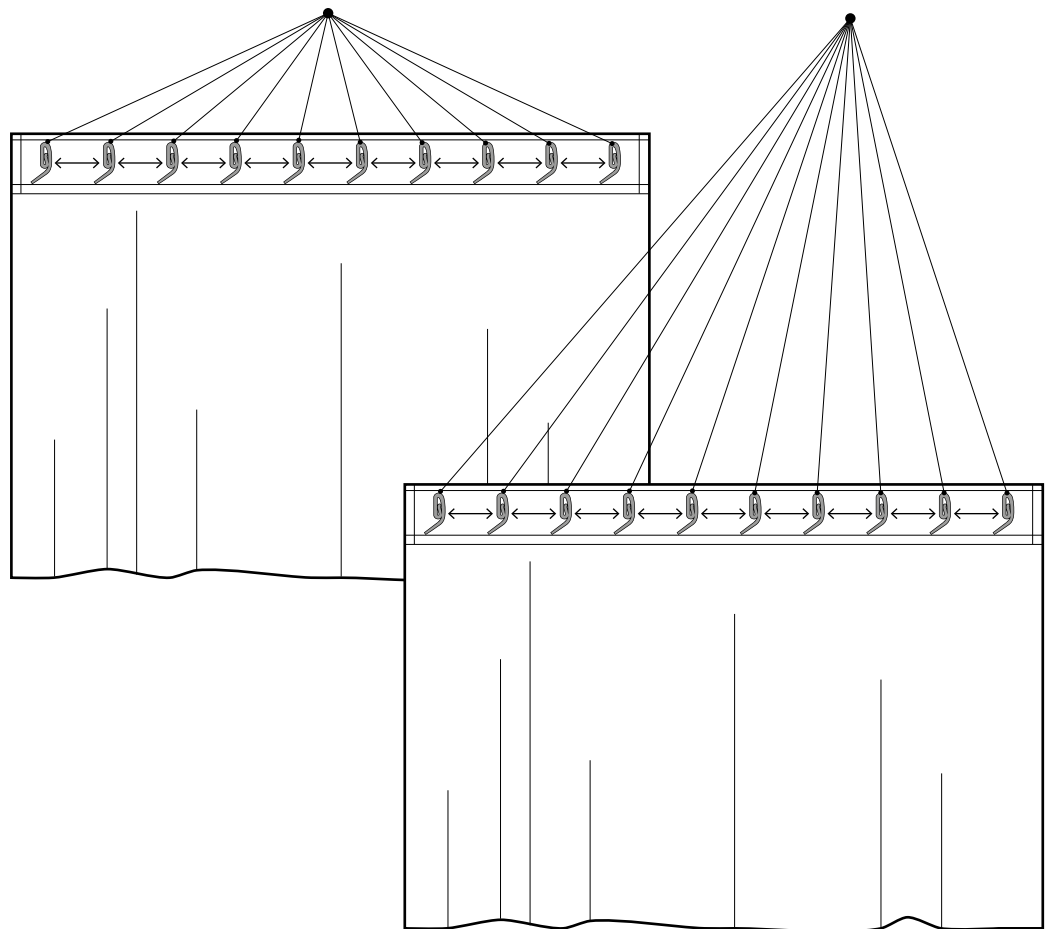



4A

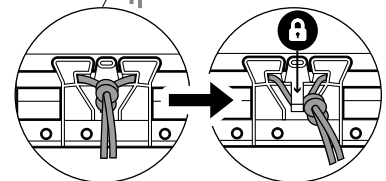
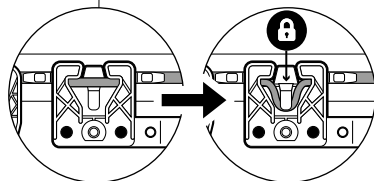
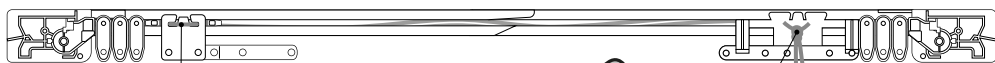
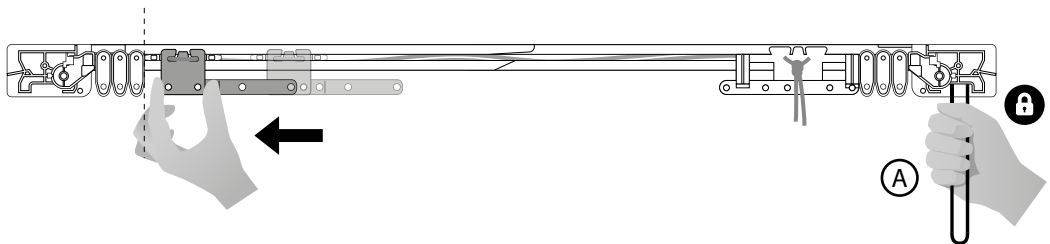
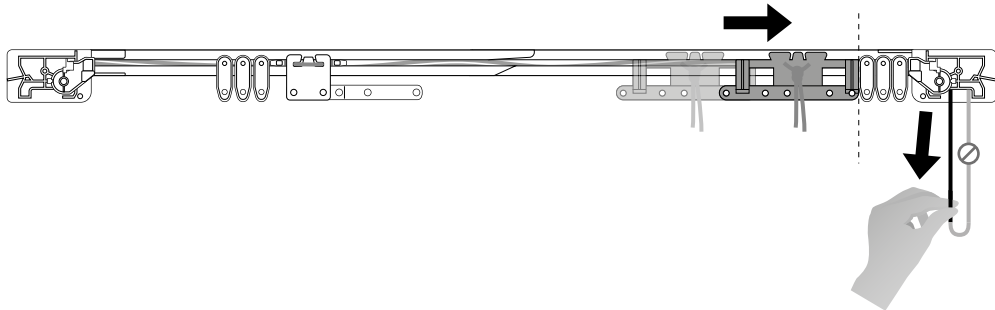
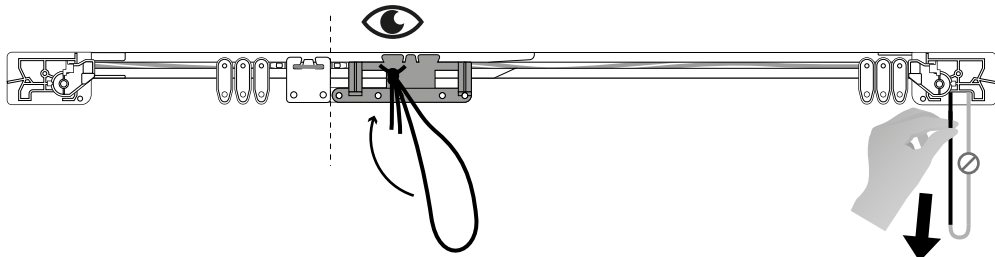
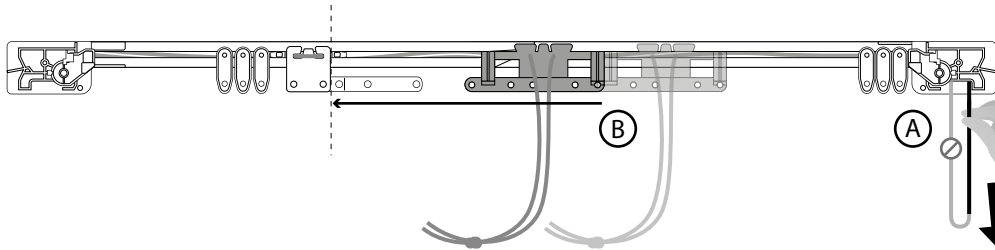
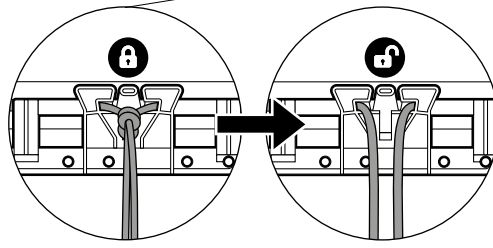
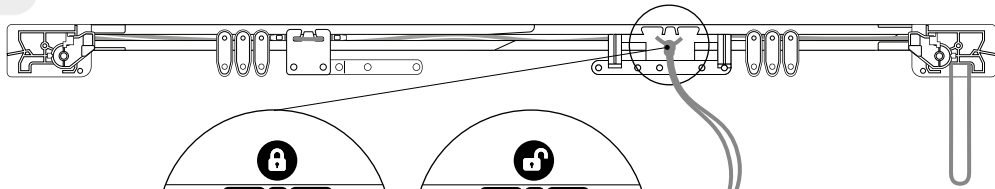



1B

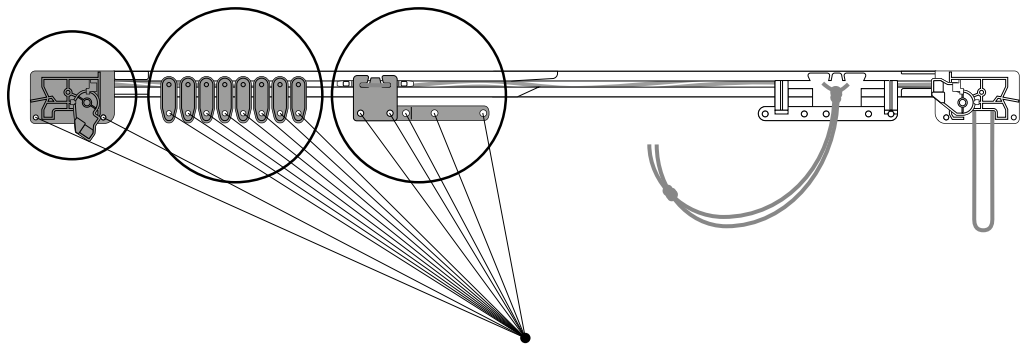
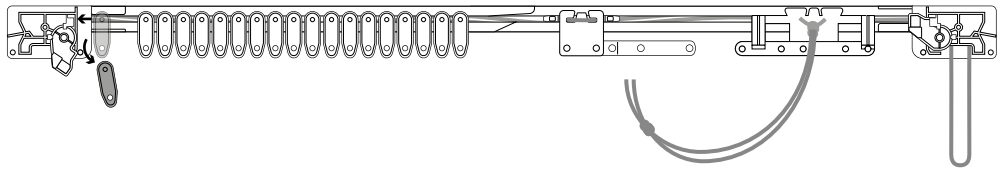
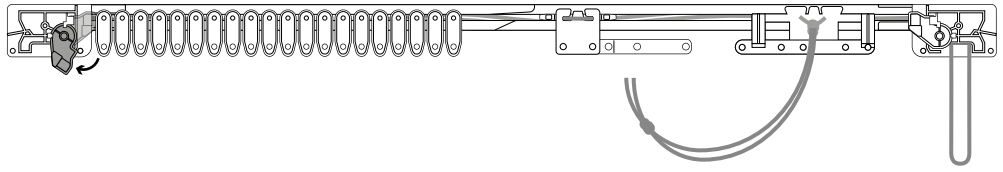
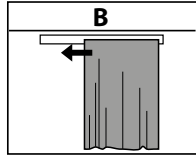

= n

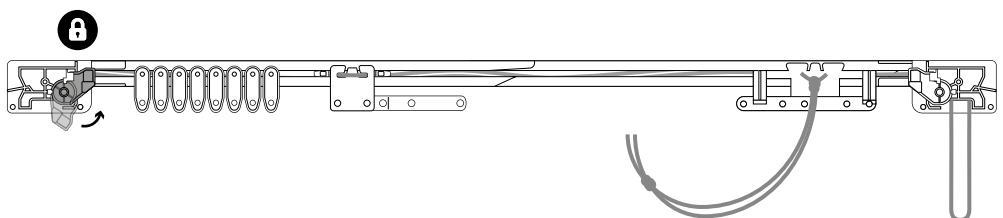
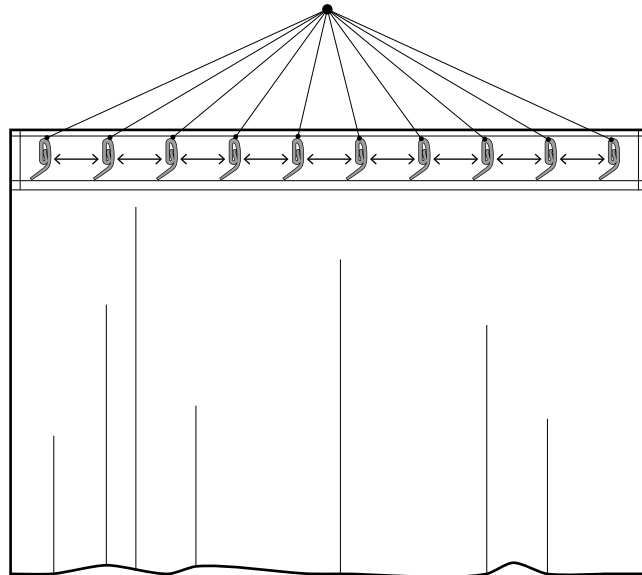



2B

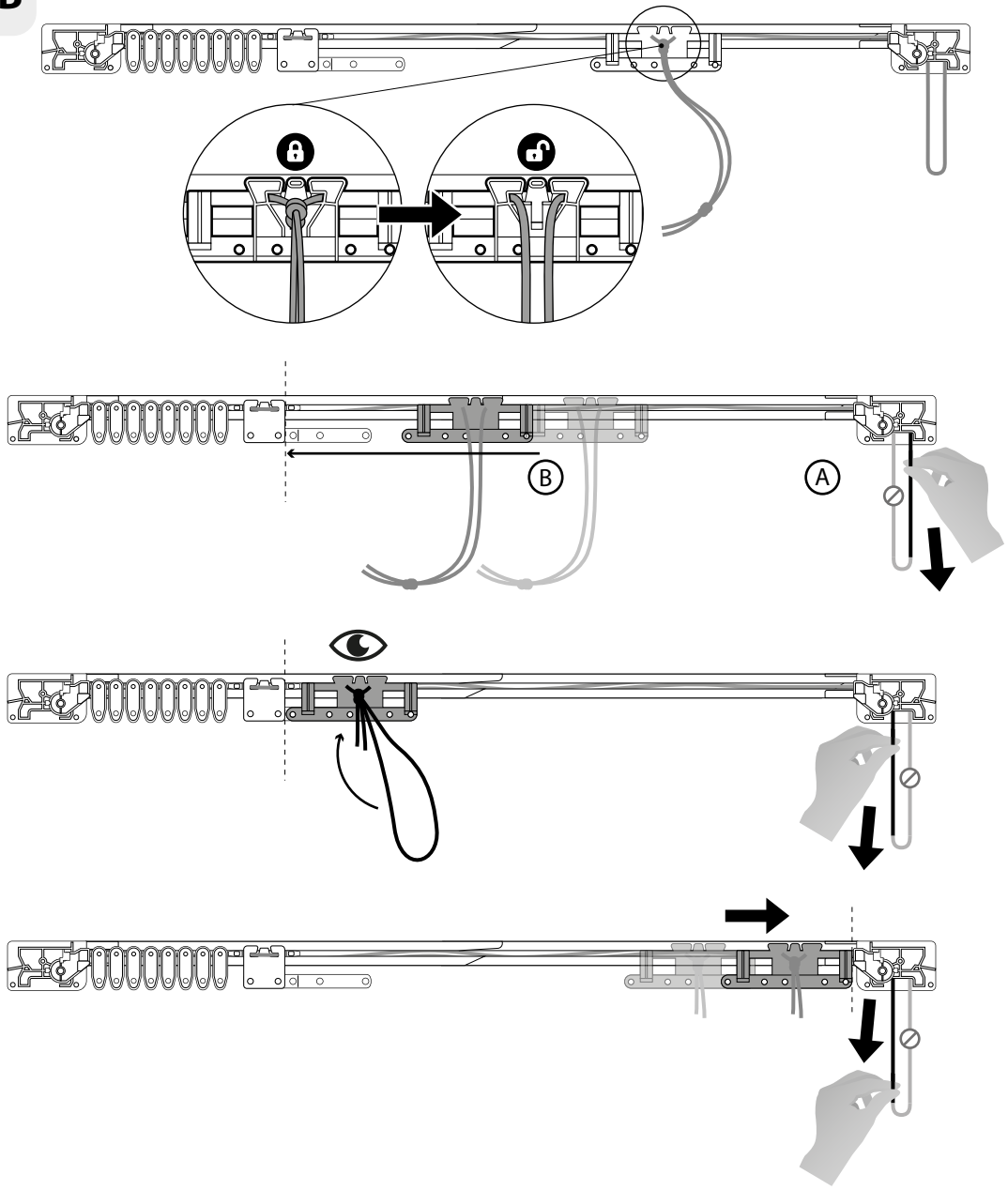

3B

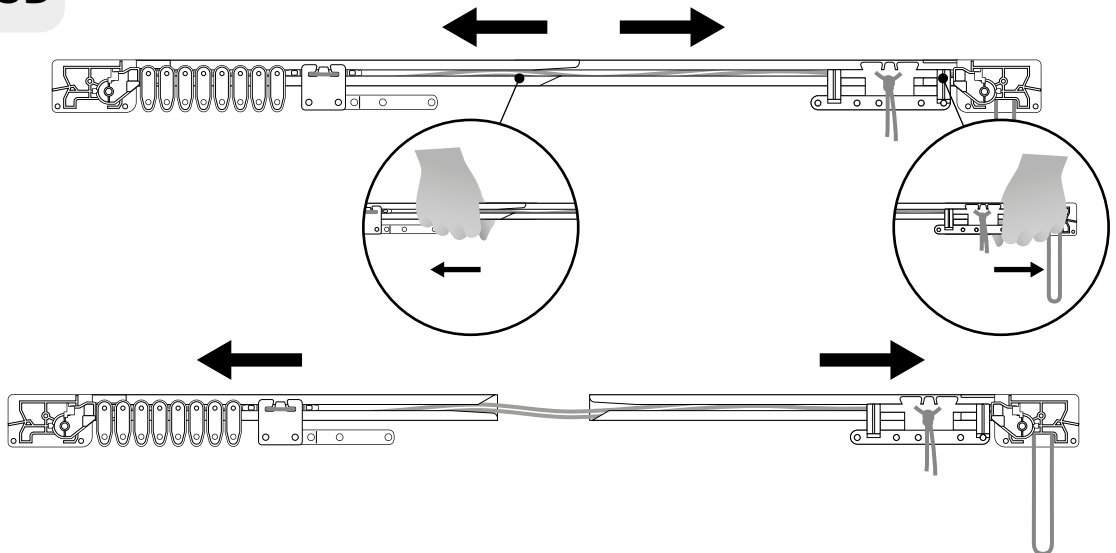



4B

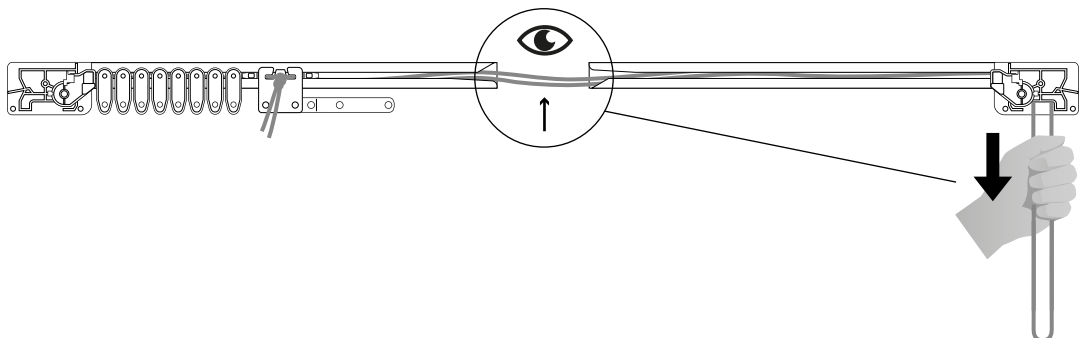
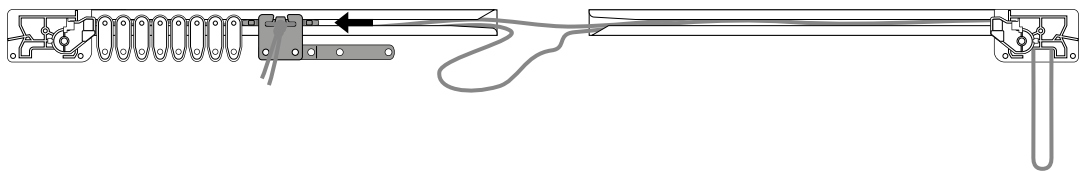
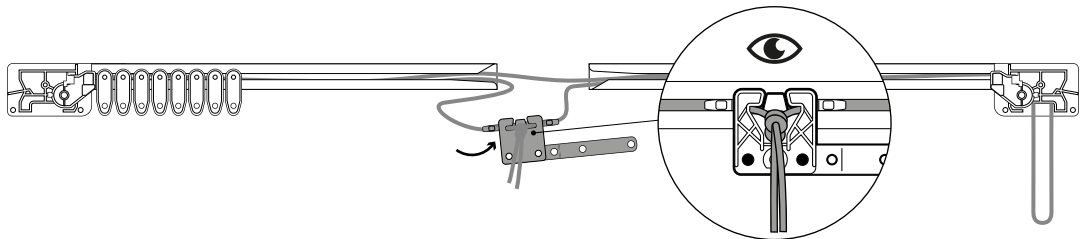
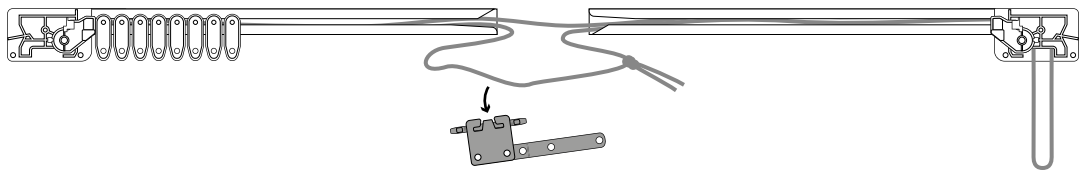
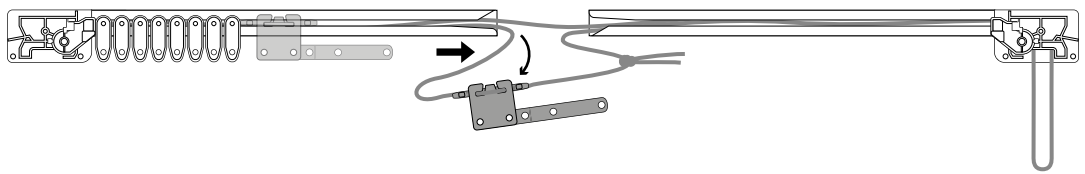
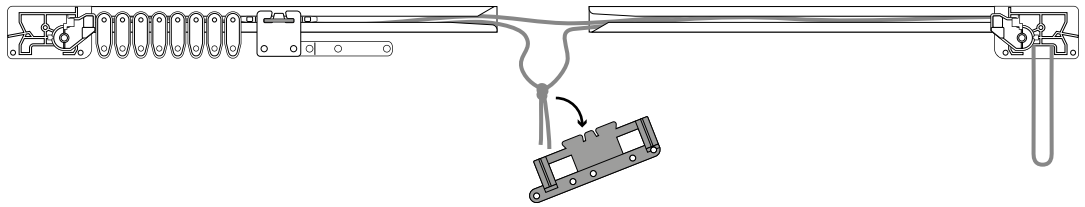
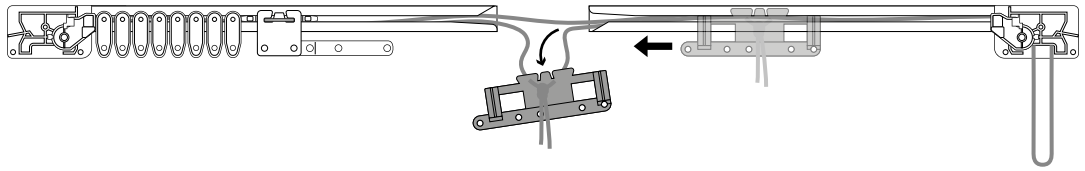



5B

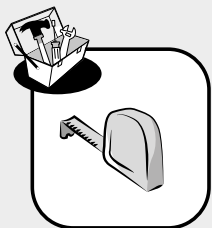
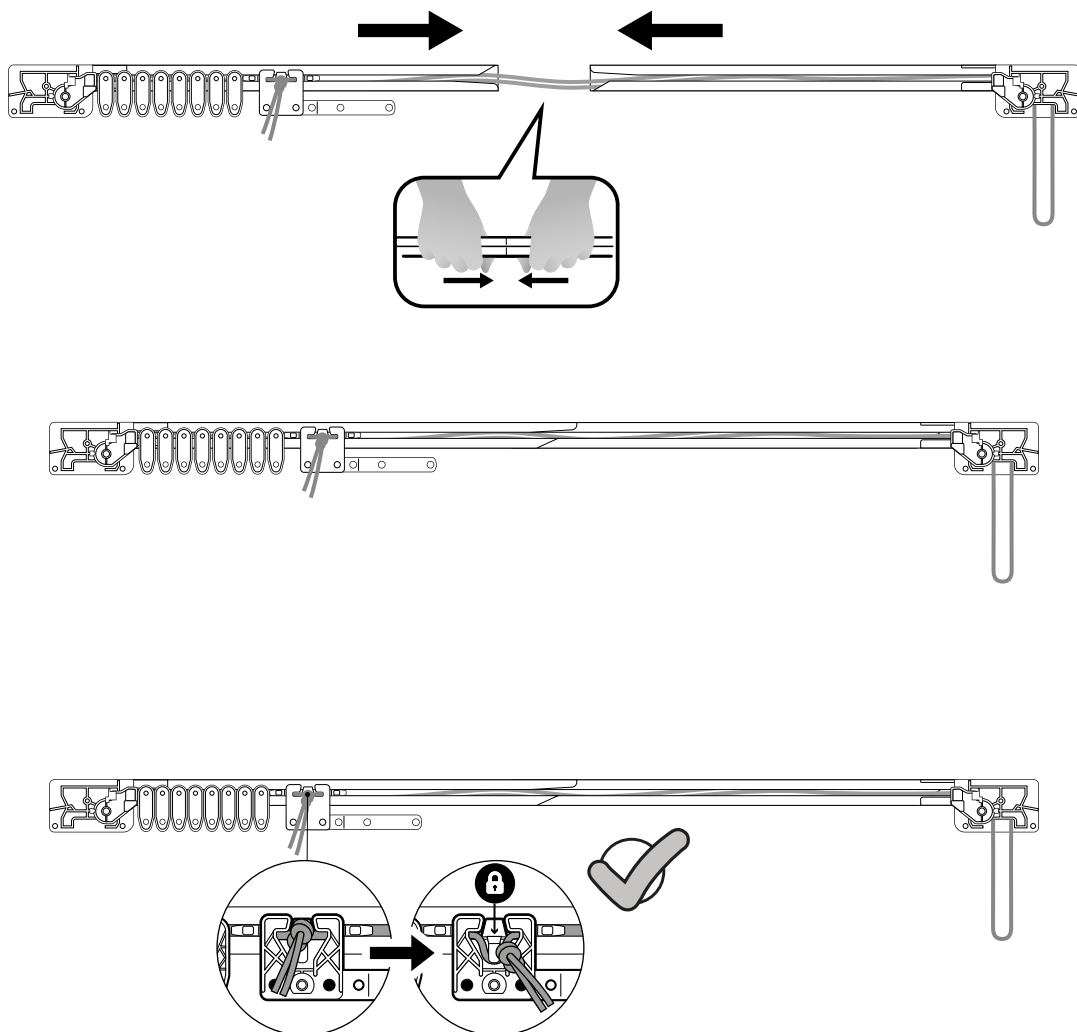

6B

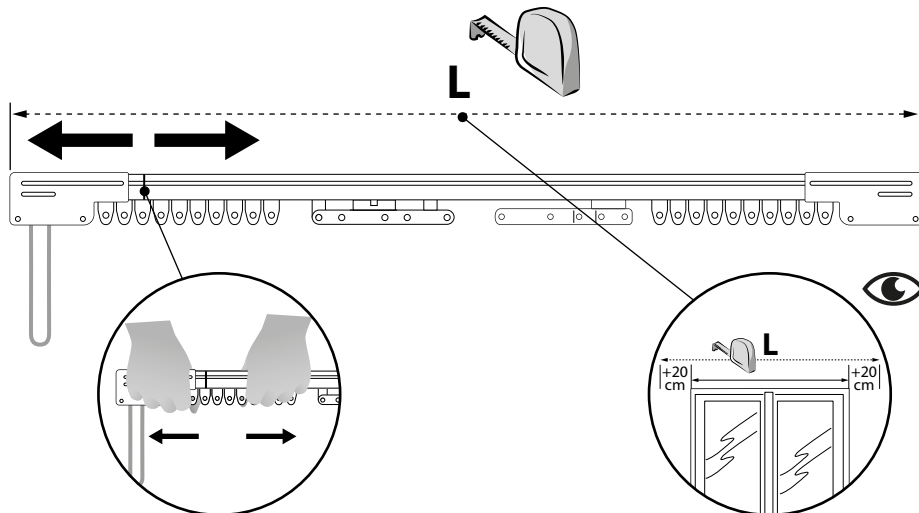



1C

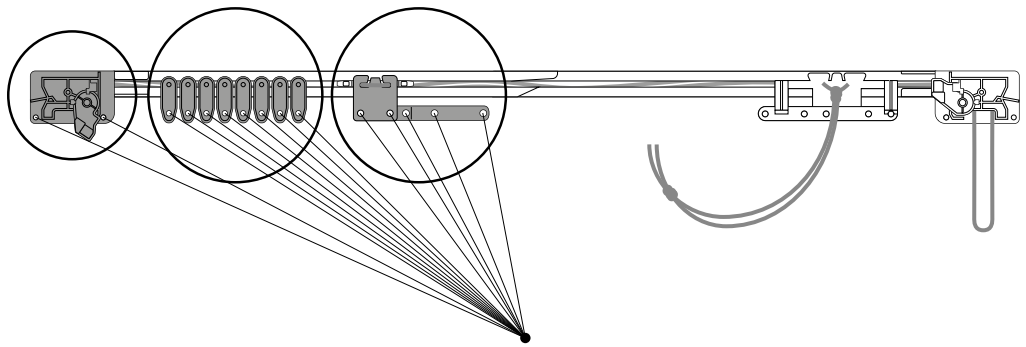
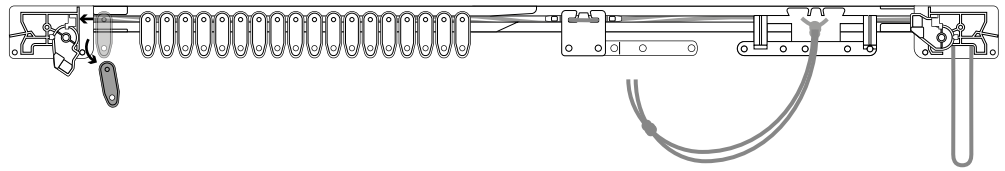
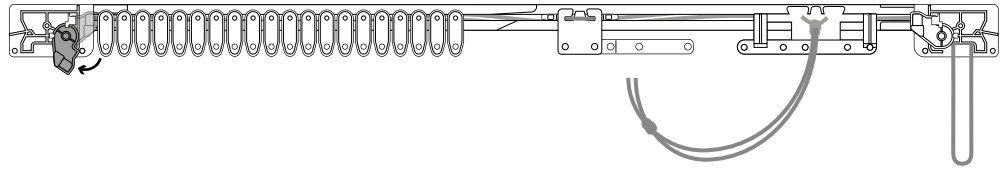
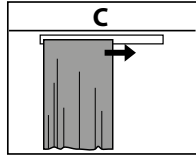

= n

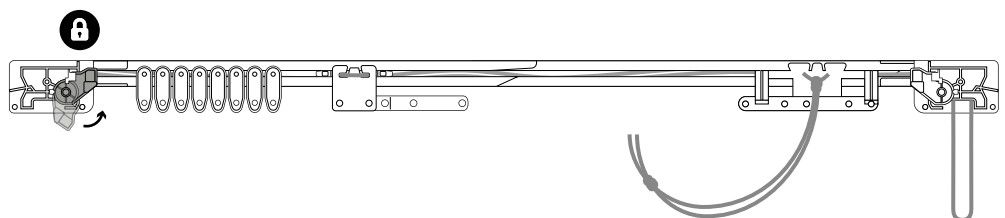
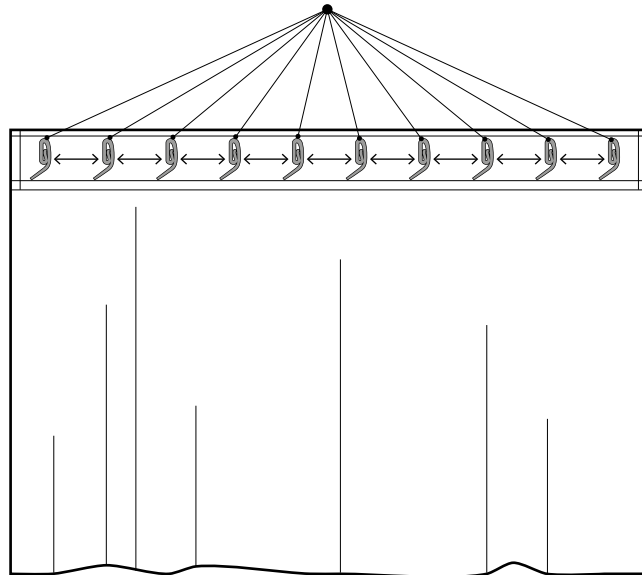



2C

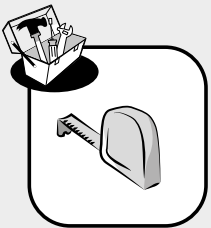
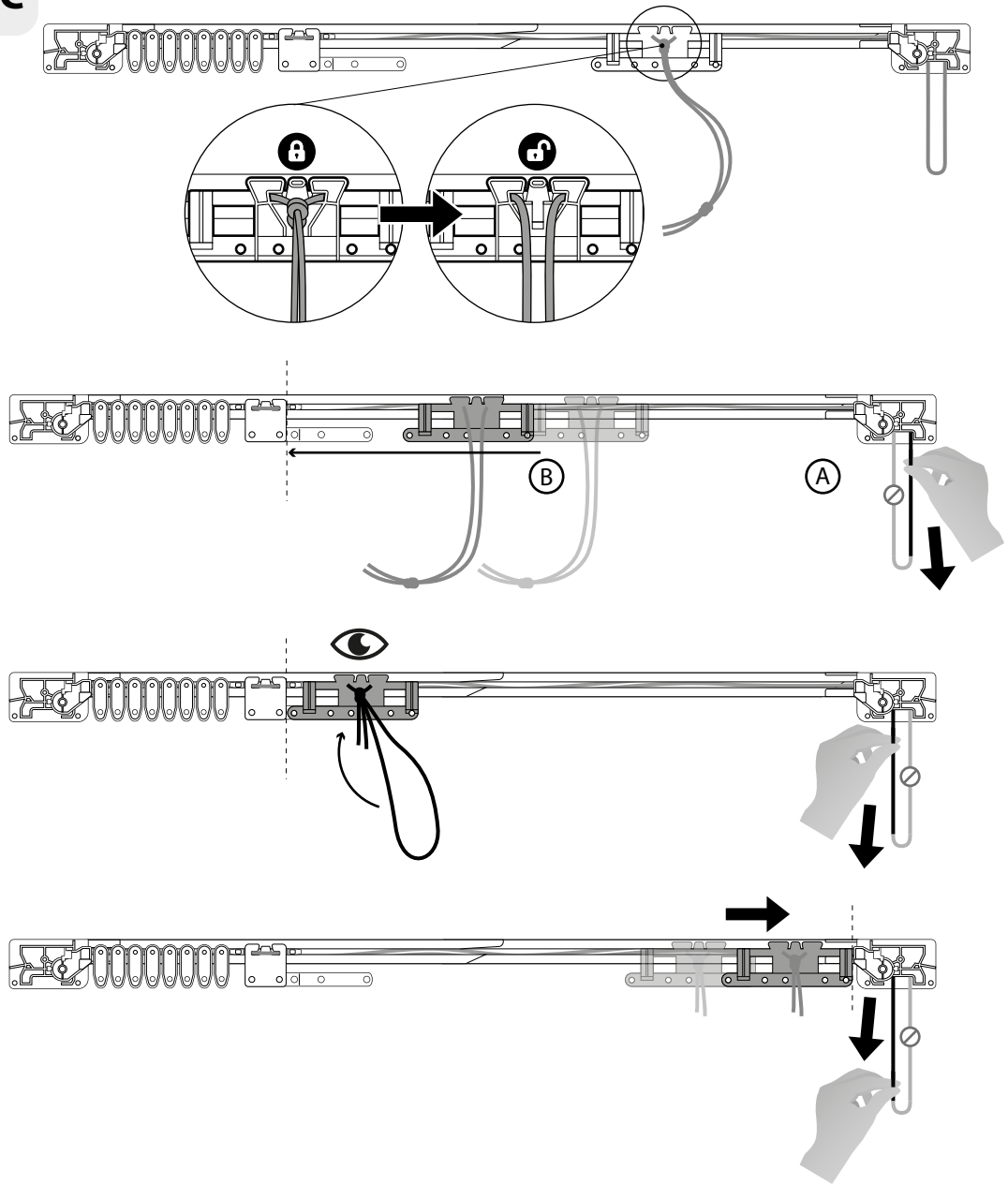

3C

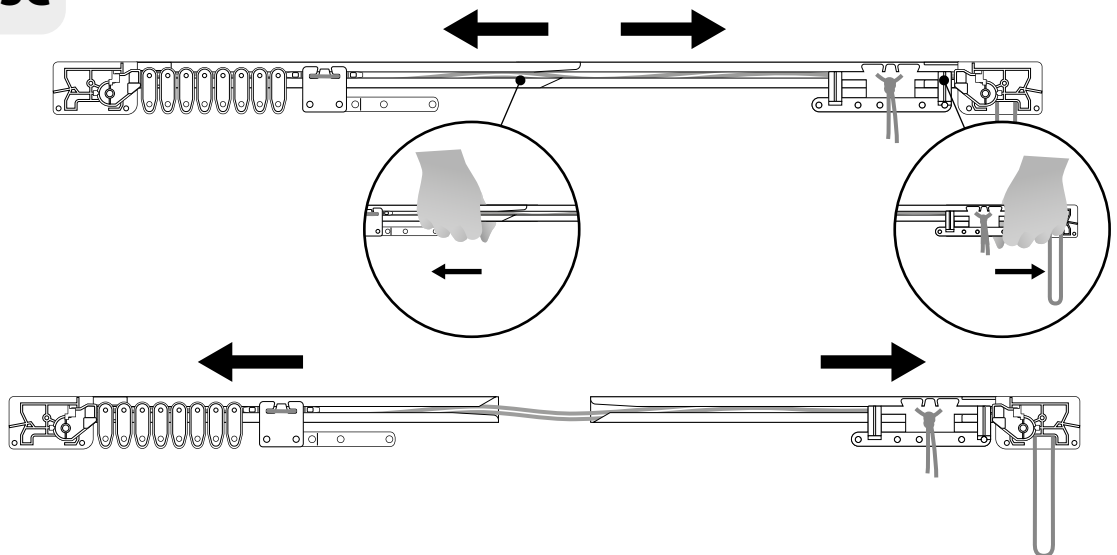



4C

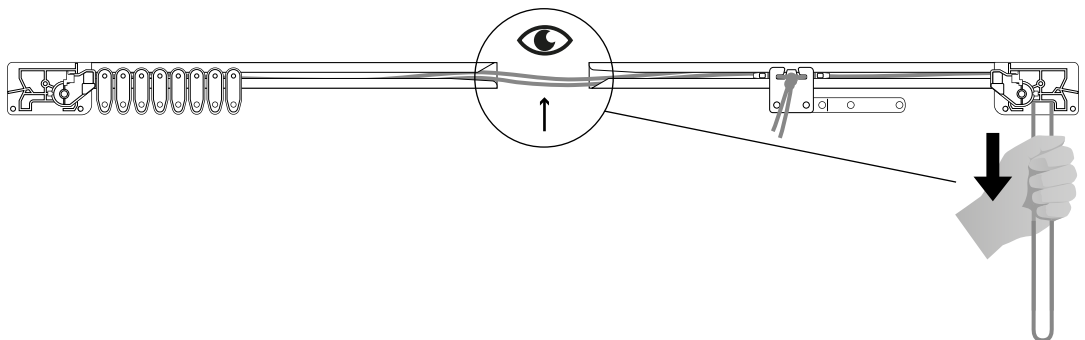
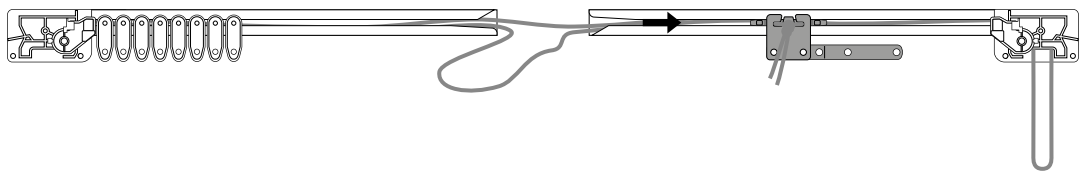
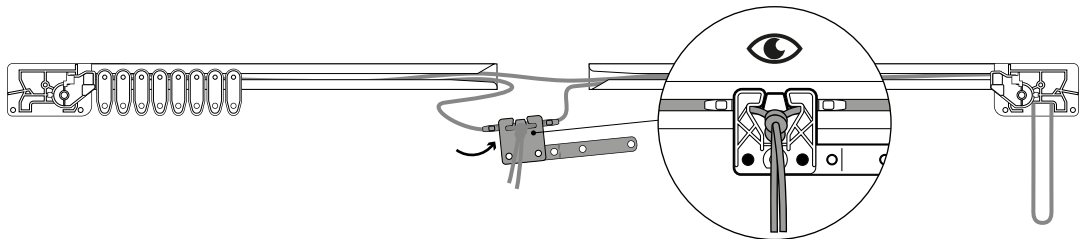
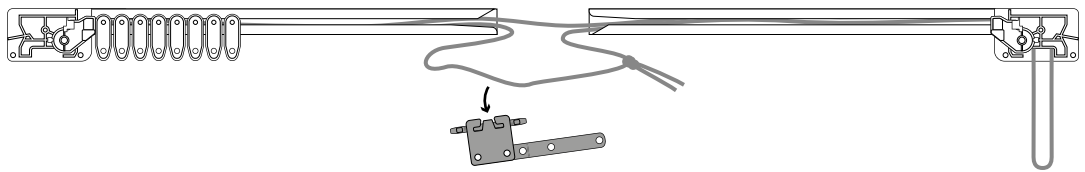
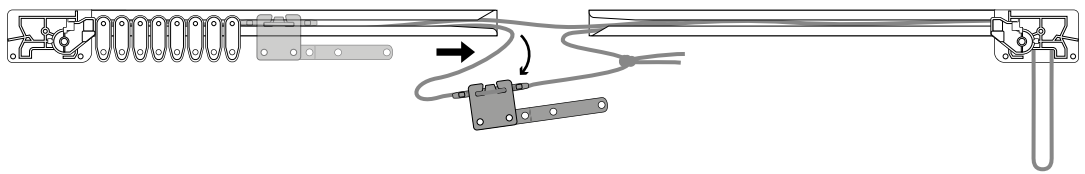
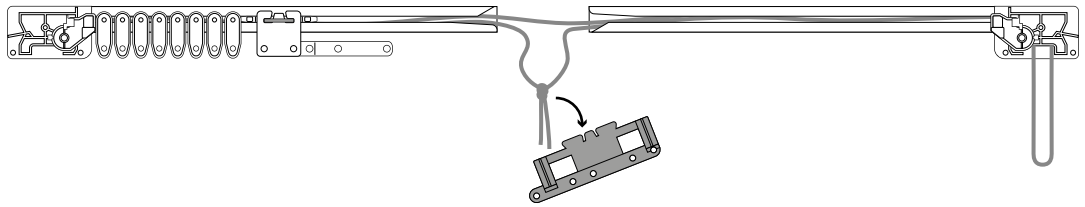
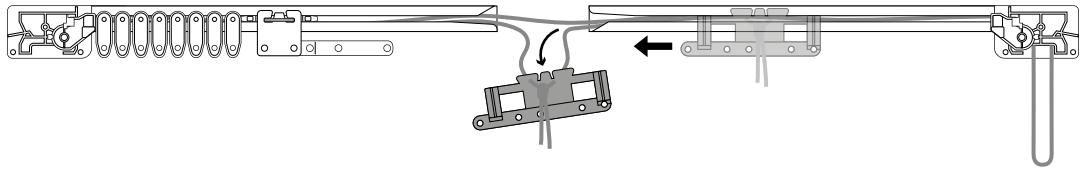



5C

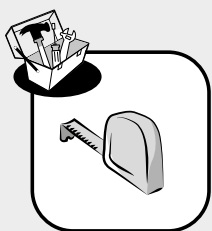
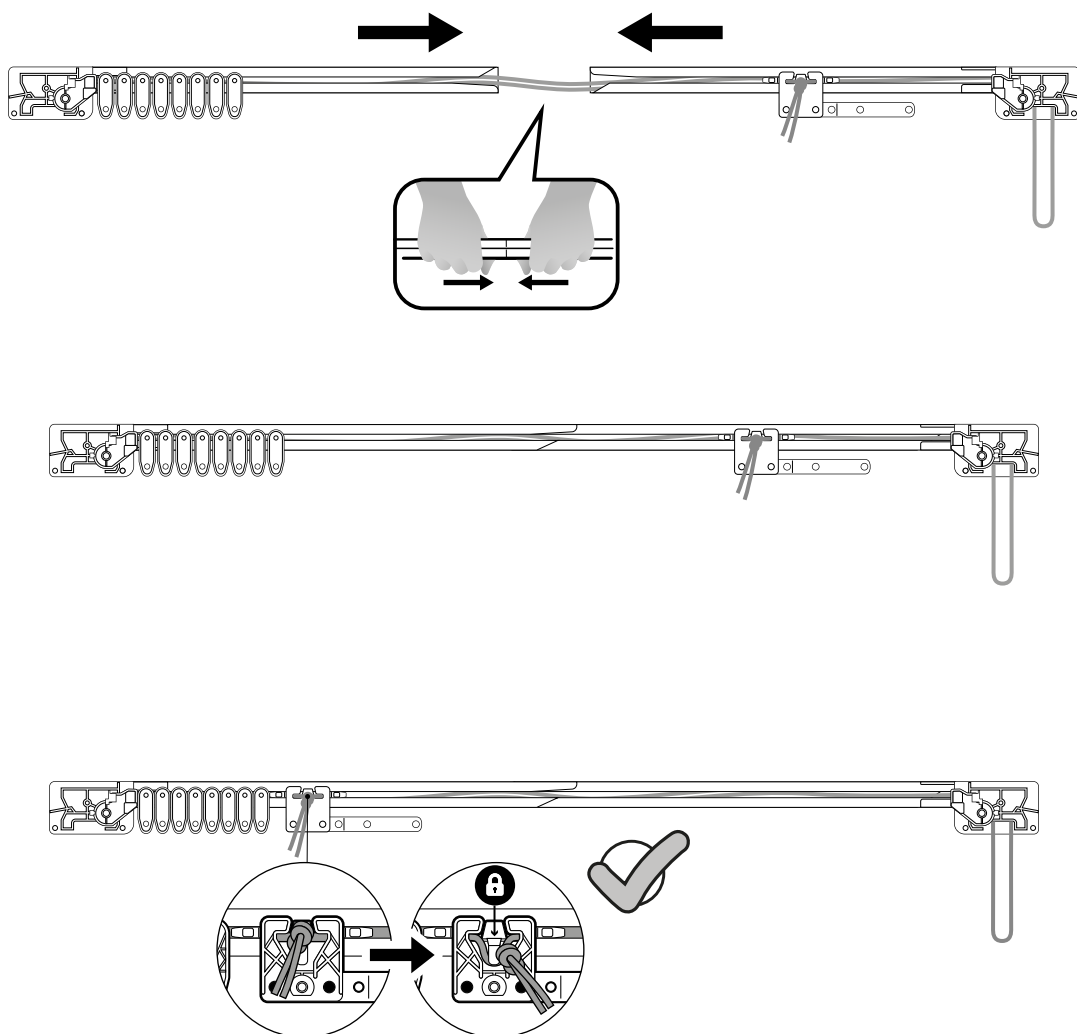

6C

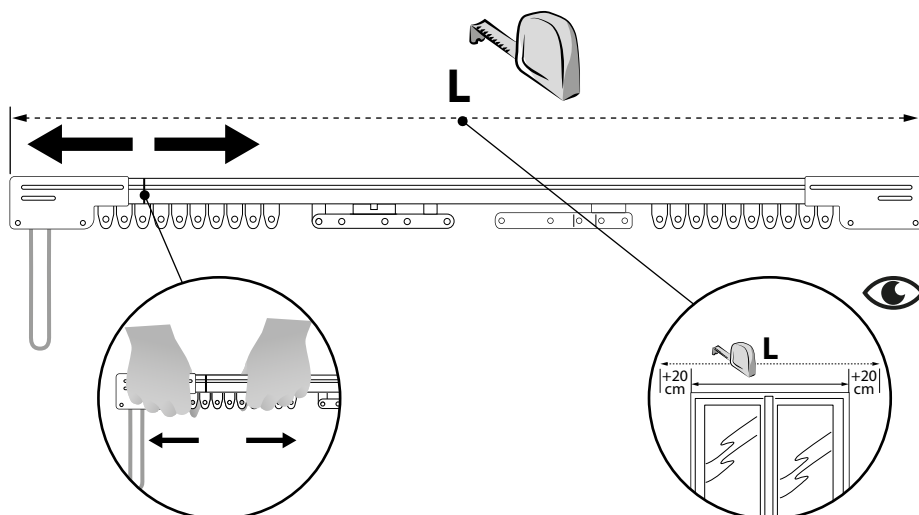



7C

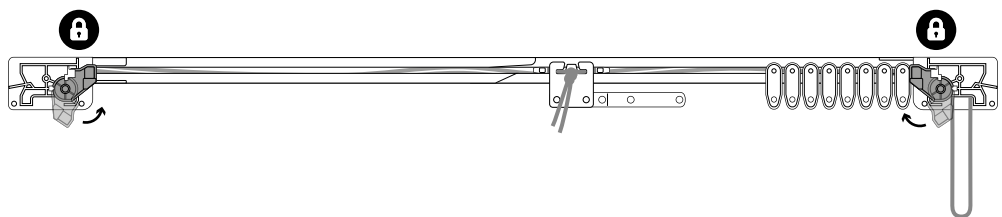
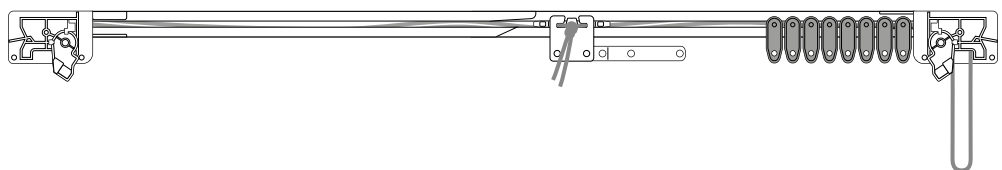
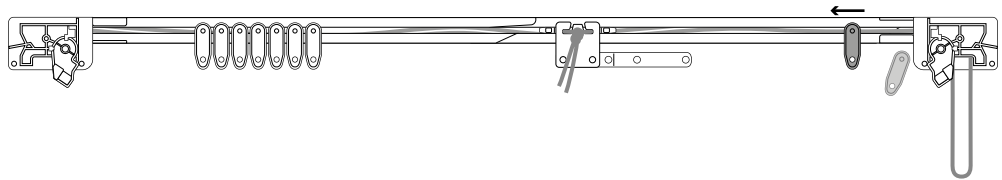
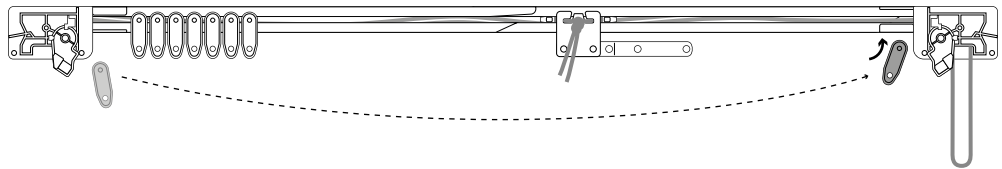
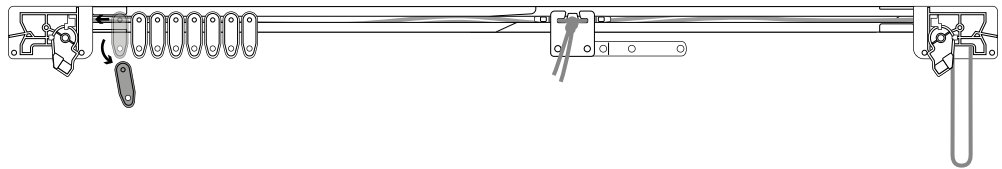
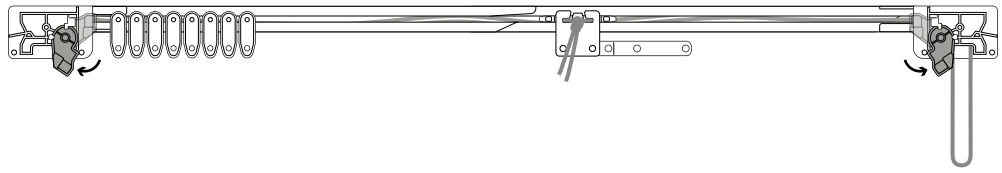



8C

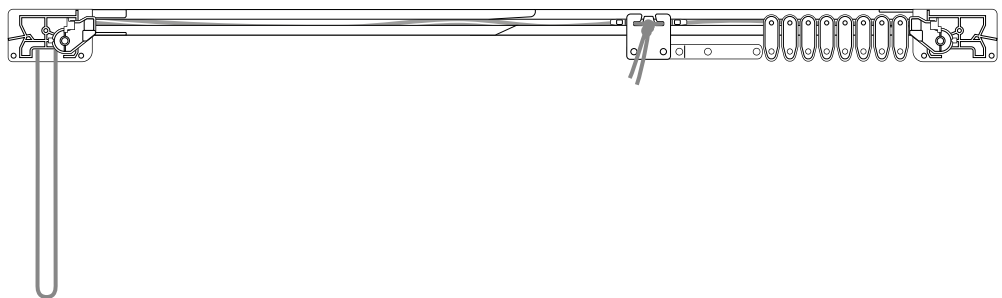
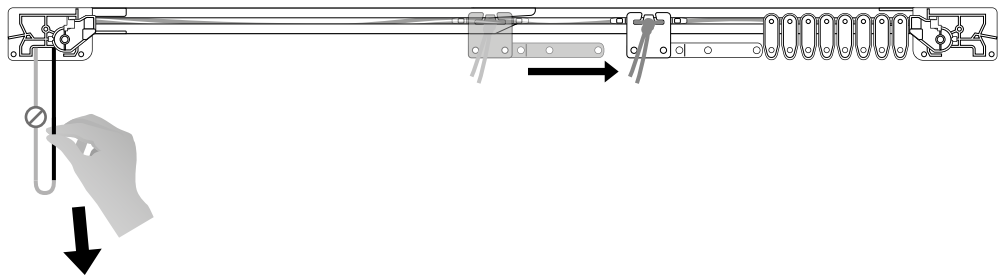
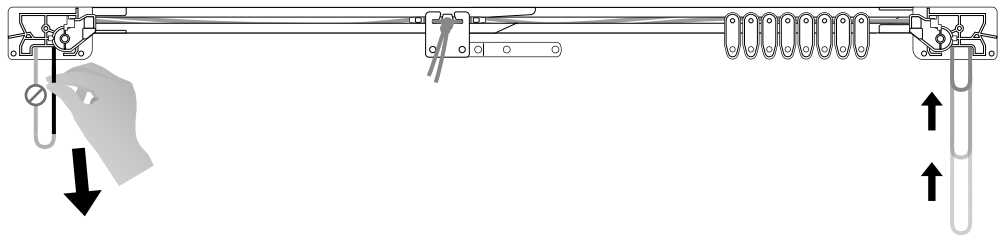
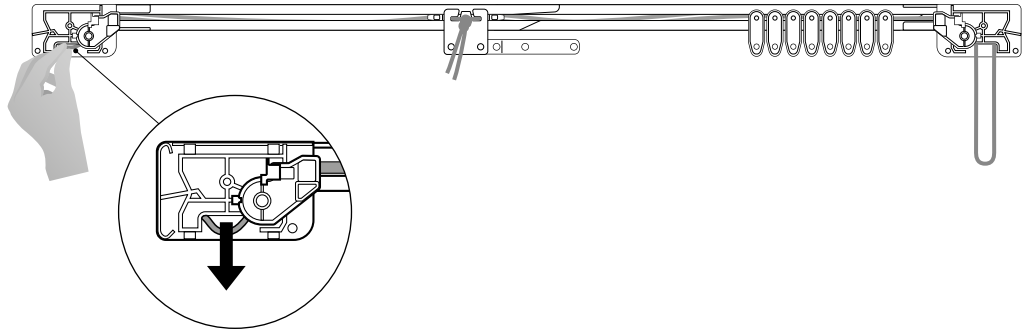
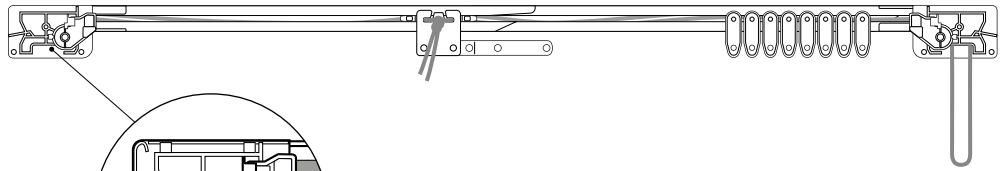



9C

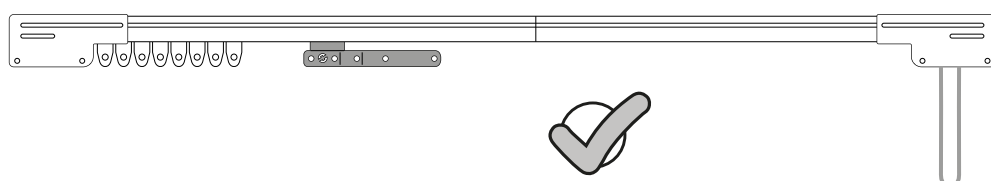
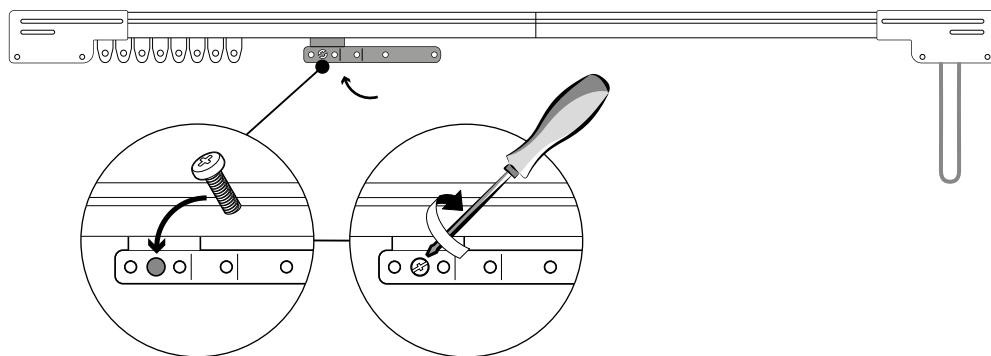
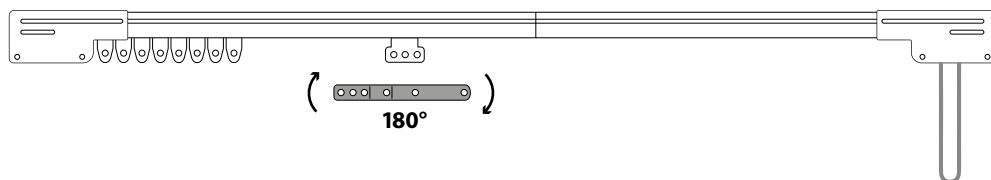
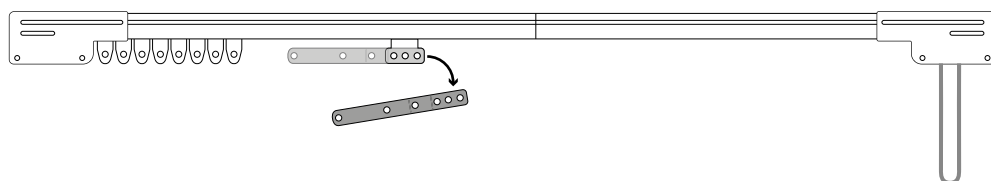
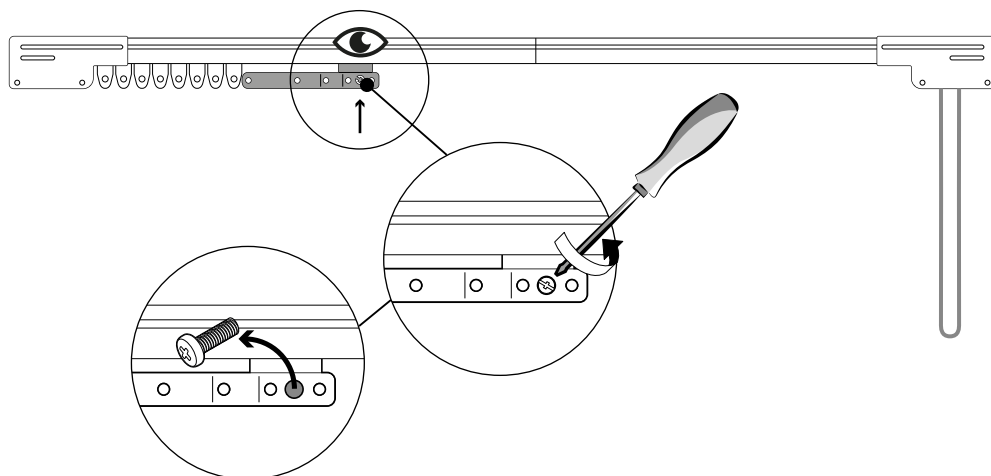
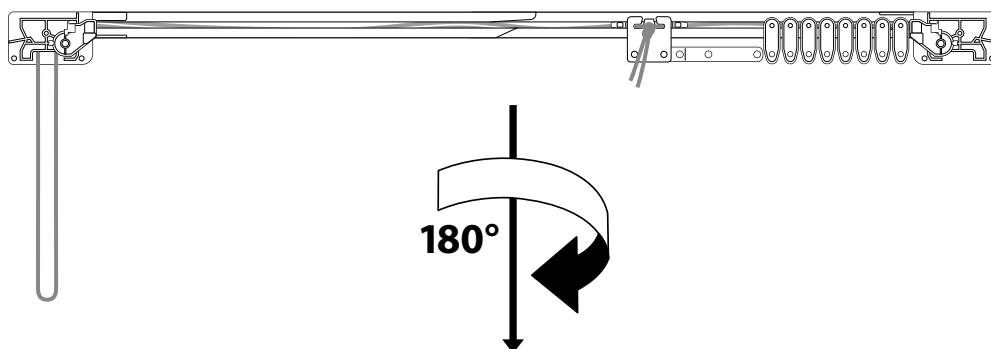
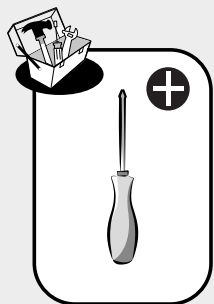



1

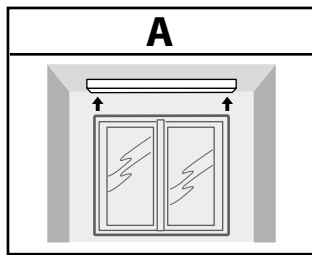

→23

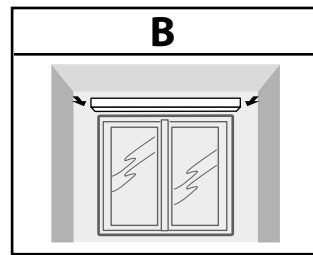

→25



X1

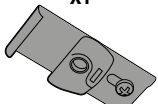

X1



X7



X7



+

-

+

-

+

-

+

-

+

-

+

-

+

-

+

-

+

-

+

-

+

-

+

-

+

-

+

-

+

-

+

-

+

-

+

-

+

-

+

-

+

A

120-210 cm

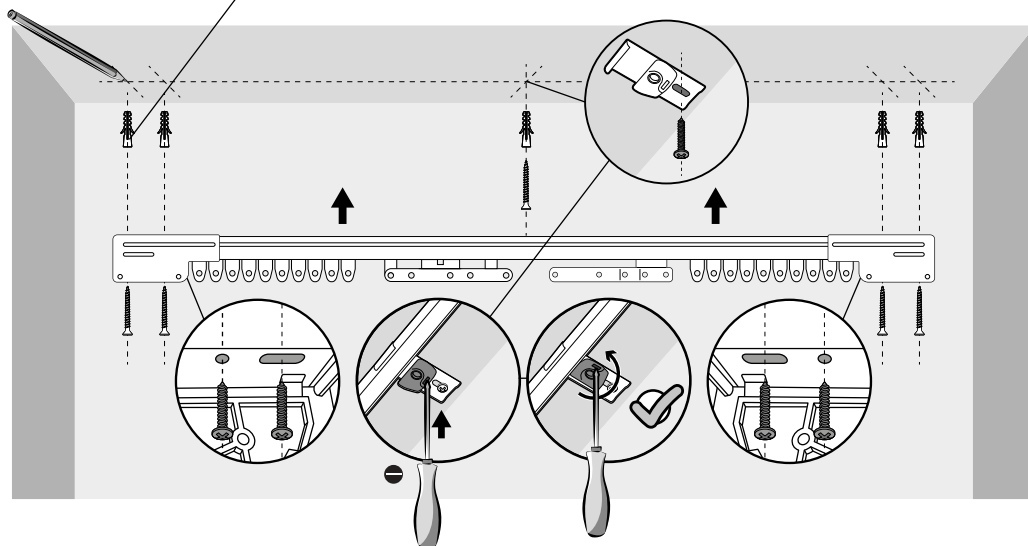
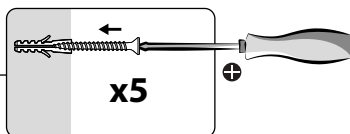
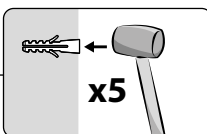
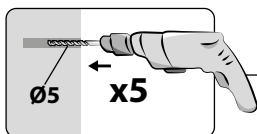
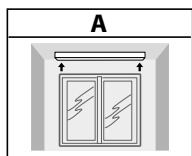

1A

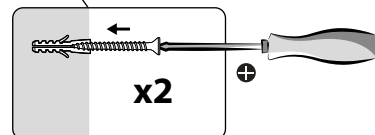
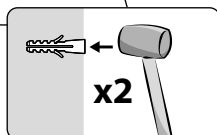
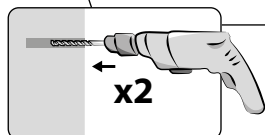
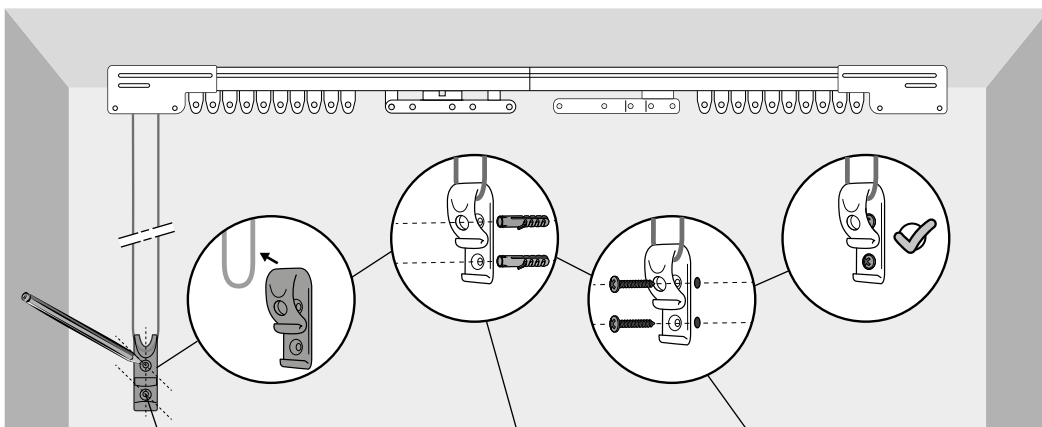



A

210-360 cm

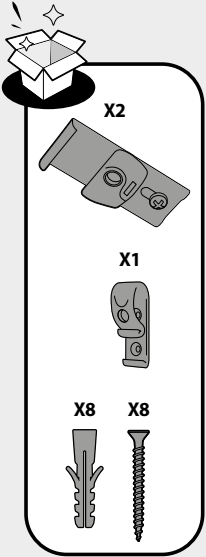
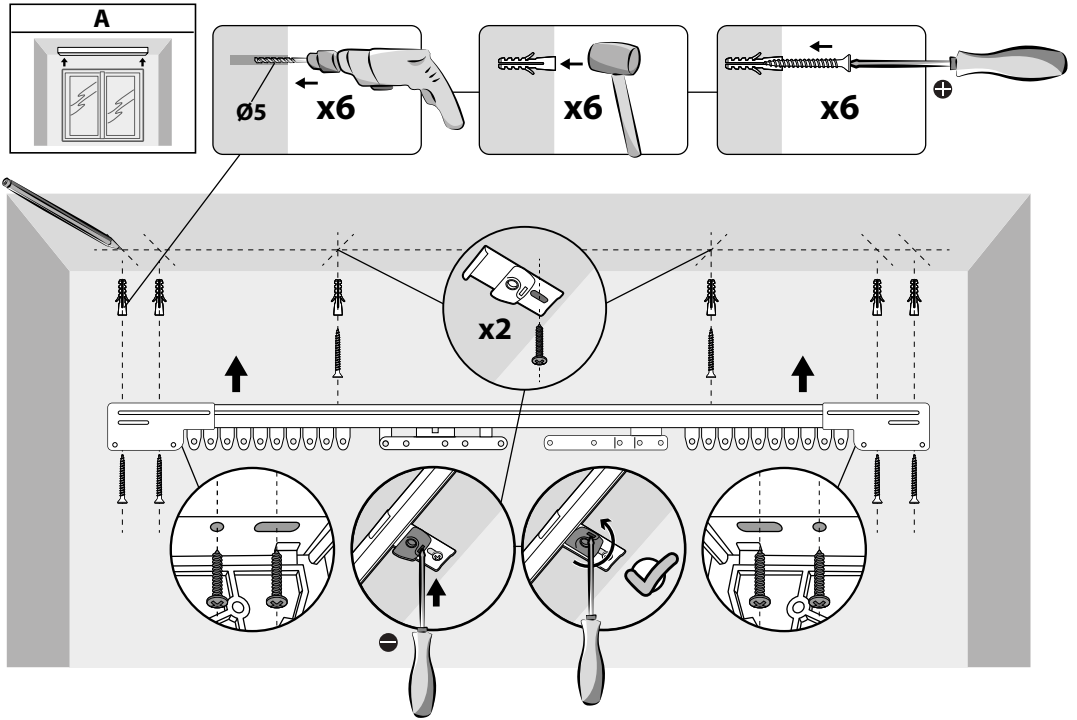

1A

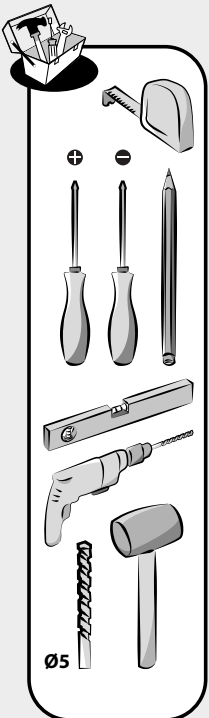
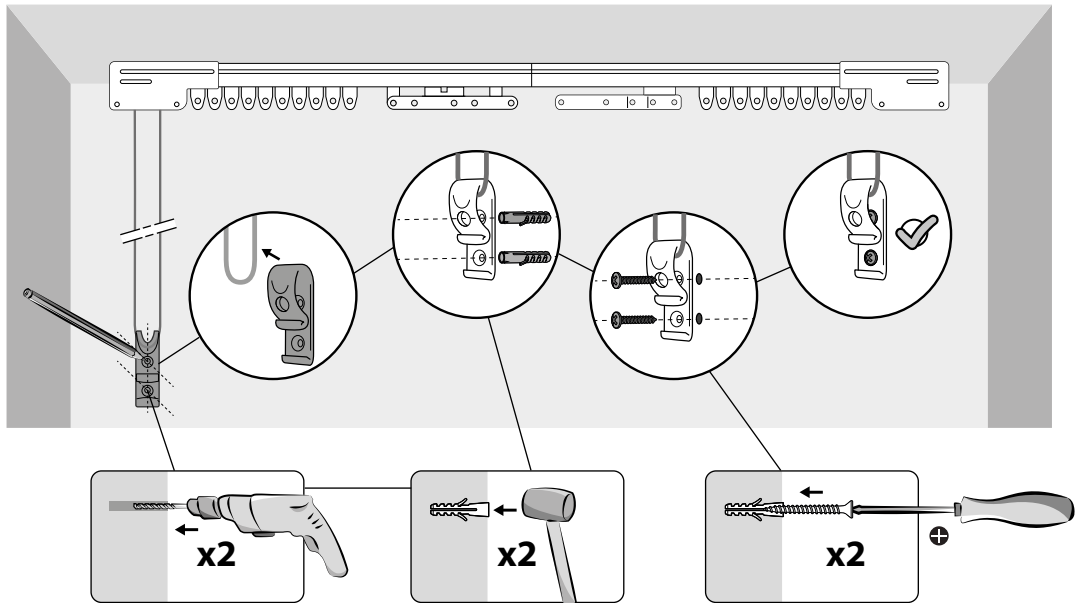



B

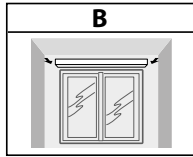

120-210 cm

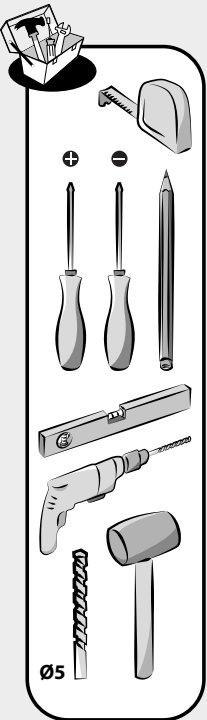
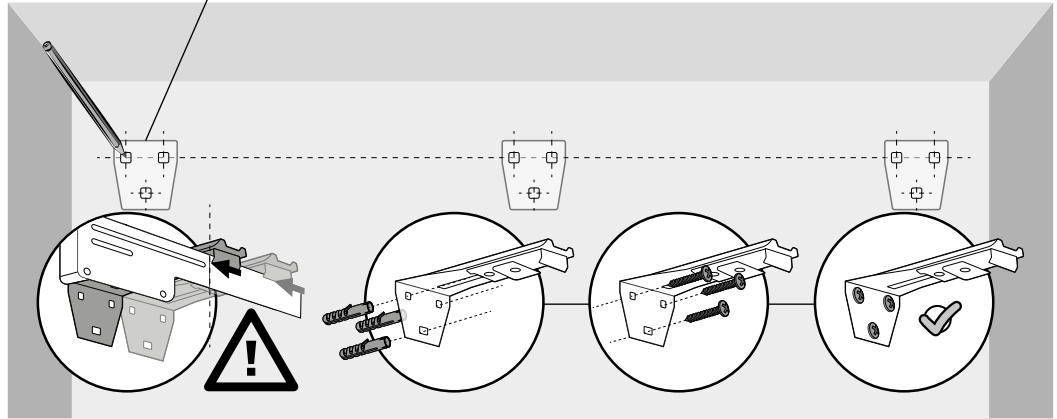
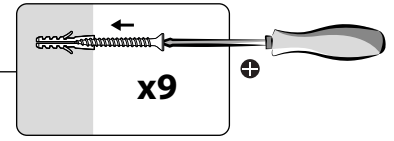
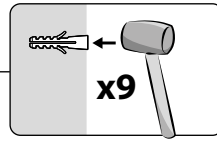
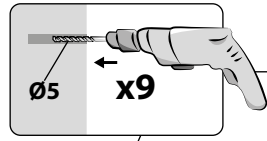
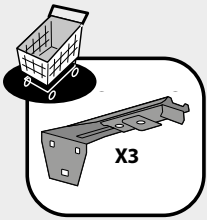
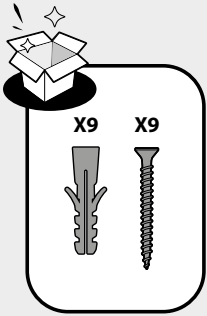
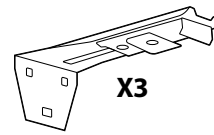

1B

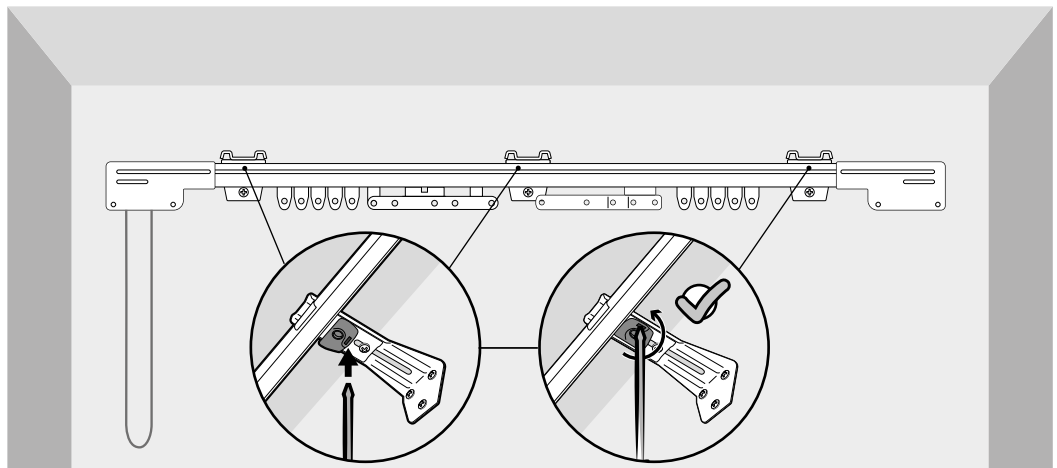
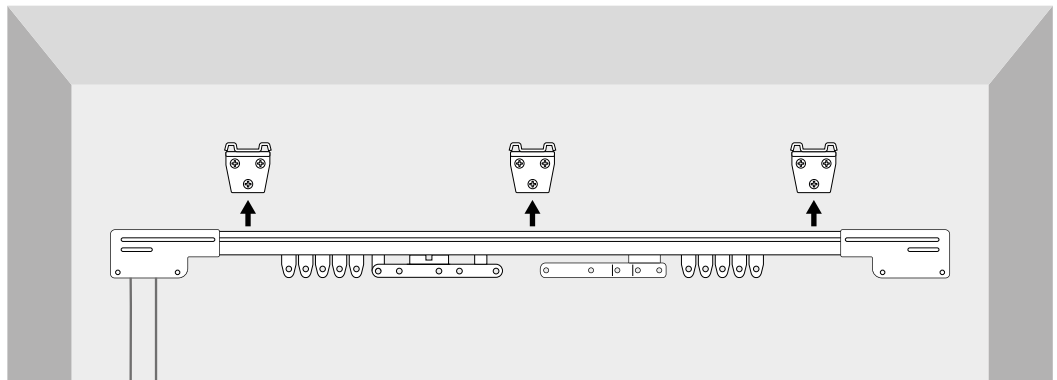



B

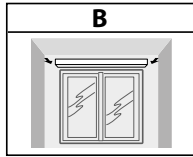

210-360 cm

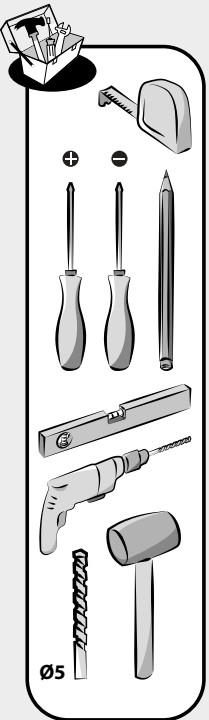
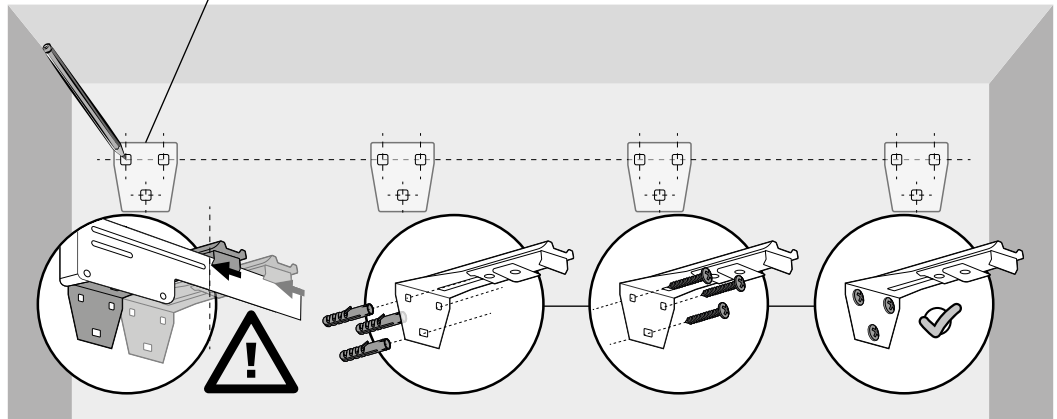
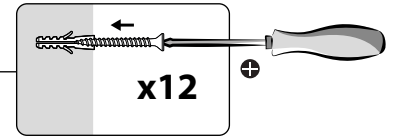
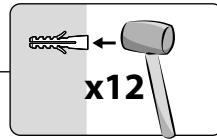
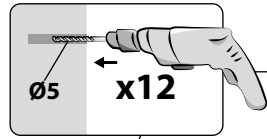
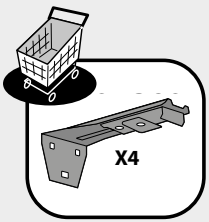
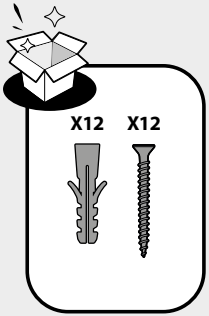
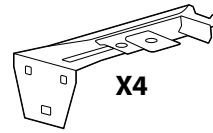

1B

