

- FR** Taille-haie à essence
- ES** Cortasetos de gasolina
- PT** Corta-sebes a gasolina
- IT** Tagliasiepi a benzina
- EL** Θαμνοκοπτικό βενζίνης
- PL** spalinowe nożyce do żywopłotu
- UA** Бензоножиці для живоплоту
- RO** Foarfece de tăiat gard viu cu motor pe benzină
- EN** Petrol Hedge Trimmer

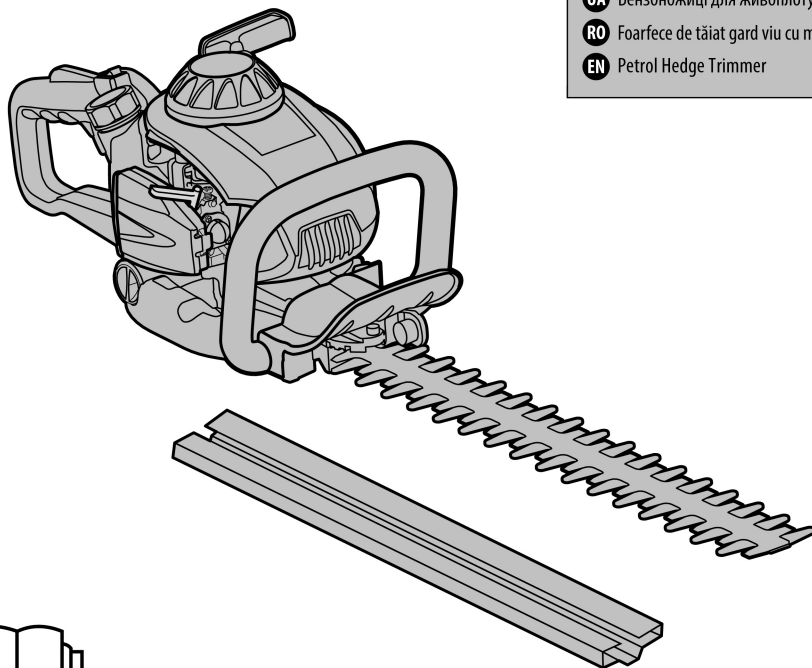

EAN:3276000696568

FR Notice de Montage -
Utilisation - Entretien

ES Instrucciones de Montaje,
Utilización y Mantenimiento

PT Instruções de Montagem,
Utilização e Manutenção

IT Istruzioni per il Montaggio,
l'Uso e la Manutenzione

EL Εγχειρίδιο συναρμολόγησης,
χρήσης και συντήρησης

PL Instrukcja Montażu,
Użytkowania i Konserwacji

UA Керівництво По Збірці
і Експлуатації

RO Manual asamblare,
utilizare și întreținere

EN Assembly - Use -
Maintenance Manual



- FR** Nous vous remercions d'avoir acheté ce produit STERWINS. Nous vous conseillons de lire attentivement la notice d'installation, d'utilisation et d'entretien. Nous avons conçu ce produit STERWINS pour vous apporter entière satisfaction.
Si vous avez besoin d'aide l'équipe de votre magasin est à votre disposition pour vous accompagner
- ES** Le agradecemos haber comprado este producto STERWINS. Le recomendamos leer atentamente el manual de instalación, uso y mantenimiento. Este producto STERWINS ha sido diseñado para proporcionarle plena satisfacción.
Si necesita alguna ayuda, el personal de la tienda estará a su disposición para guiarle.
- PT** Agradecemos a sua preferência por este produto STERWINS. Aconselhamo-lo a ler o manual de instalação, utilização e manutenção com atenção. Criámos este produto STERWINS para sua completa satisfação.
Se precisar de ajuda, a equipa da sua loja está à sua disposição para o acompanhar.
- IT** Grazie per aver acquistato questo prodotto STERWINS. Vi raccomandiamo di leggere attentamente il manuale di installazione, utilizzo e manutenzione. Questo prodotto STERWINS è stato progettato per offrirvi la massima soddisfazione.
Per ricevere assistenza, il personale del punto vendita è a vostra disposizione.
- EL** Ευχαριστούμε για την αγορά σας αυτού του προϊόντος STERWINS. Σας συμβουλεύουμε να διαβάσετε προσεκτικά τις οδηγίες εγκατάστασης, χρήσης και συντήρησης. Σχεδιάσαμε αυτό το προϊόν STERWINS για να σας προσφέρει πλήρη ικανοποίηση.
Αν χρειάζεστε βοήθεια, η ομάδα του καταστήματος από το οποίο αγοράσατε το προϊόν είναι στη διάθεσή σας
- PL** Dziękujemy za zakup produktu firmy STERWINS. Zalecamy, aby uważnie przeczytać instrukcję instalacji, użytkowania i konserwacji. Ten produkt marki STERWINS zaprojektowaliśmy, aby spełnić wszystkie Państwa oczekiwania.
W razie potrzeby pracownicy sklepu służą Państwu pomocą i są do Państwa dyspozycji.
- UA** Дякуємо вам за покупку цього виробу STERWINS. Ми радимо вам уважно прочитати інструкції з установлення, експлуатації та технічного обслуговування. Ми розробили цей виріб STERWINS для того, щоб він приносив вам задоволення.
Якщо вам потрібна допомога, співробітники вашого магазину готові допомогти вам
- RO** Vă mulțumim pentru achiziționarea acestui produs STERWINS. Vă sfătuim să citiți cu atenție instrucțiunile de instalare, de utilizare și de întreținere. Am conceput acest produs STERWINS pentru a vă furniza satisfacție totală. Dacă aveți nevoie de ajutor, echipa magazinului de cumpărare este la dispoziția dumneavoastră pentru a vă asista.
- EN** Thank you for purchasing this STERWINS product. We recommend that you read the installation, user and maintenance instructions carefully. We have designed this STERWINS product to ensure your complete satisfaction.
If you require assistance, the team at your retailer is on hand to help you.

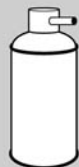
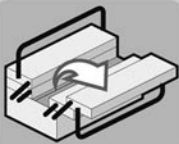
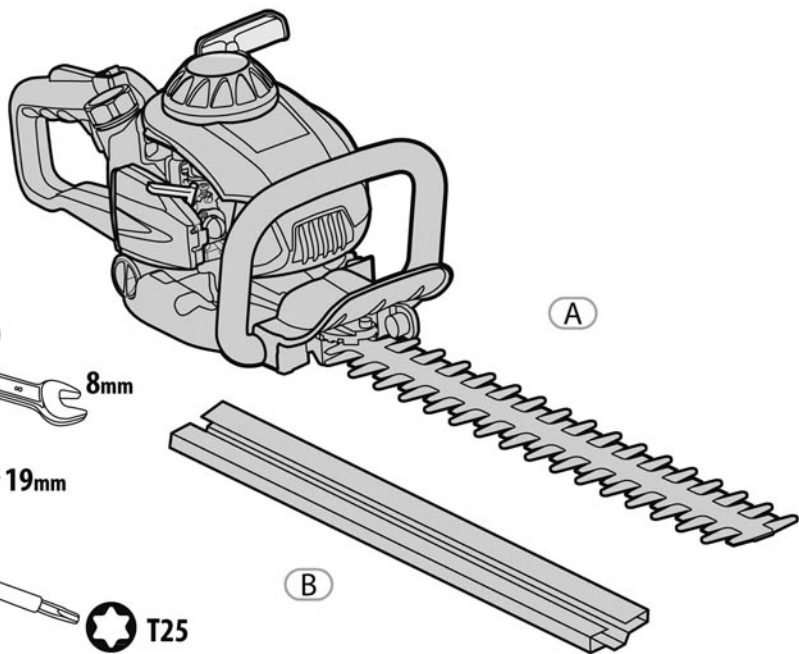
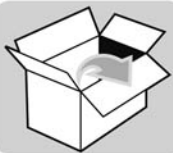

Attention danger / Atención: Peligro / Atencção perigo / Attenzione pericolo / Προσοχή κίνδυνος / Uwaga niebezpieczeństwo / Увара! Небезпечно! / Atenție, pericol / Caution danger



Nettoyage / Limpieza / Limpeza / Pulizia / Καθαρισμός / Czyszczenie / Очищення / Curățare / Cleaning



Observez / Atención / Aviso / Osservare / Προσέξτε / Przestrzegać / Дотримуйтеся правил техніки безпеки / Respectați / Observe



Attendre / Espera / Esperar / Attendere / Αναμονή / Zaczekać / Режим очікування / Așteptare / Wait



Pas de flamme / No encender fuegos / Não ateie fogo / Non infiammare / Απαγορεύεται φωτιά / Zakaz używania ognia / Вогнебезпечно / Nu faceți foc / No fire



Maintenance / Mantenimiento / Manutenção / Manutenzione / Σέρβις / Utrzymanie / Технічне обслуговування / Mentenanță / Maintenance



Ne pas fumer / No fumar / Não fume / Non fumare / Απαγορεύεται το κάπνισμα / Zakaz palenia tytoniu / Не палити / Nu fumați / No smoking

A

FR Préparation ES Preparación PT Preparação IT Preparazione EL Προετοιμασία PL Przygotowanie
UA Підготування RO Pregătire EN Preparation

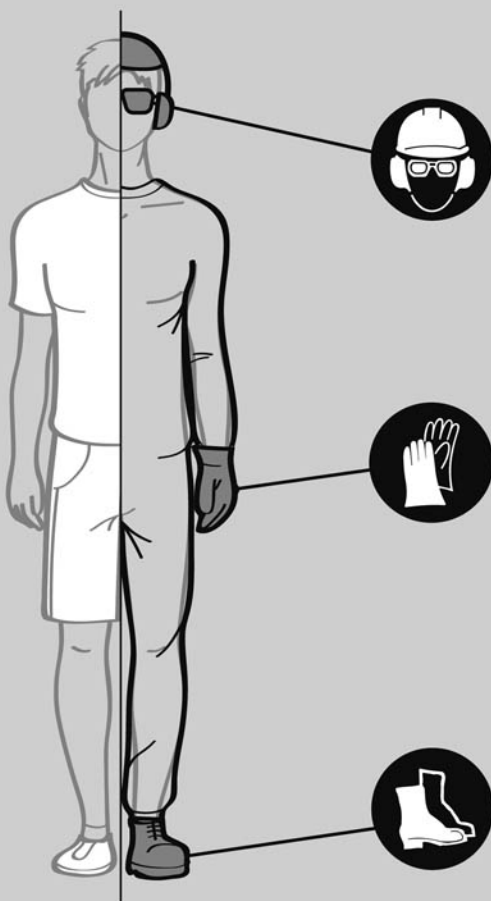

1



10 m
MINI

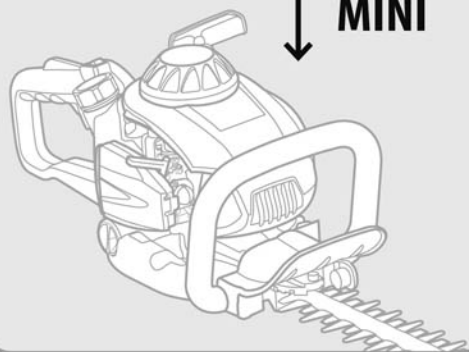

2

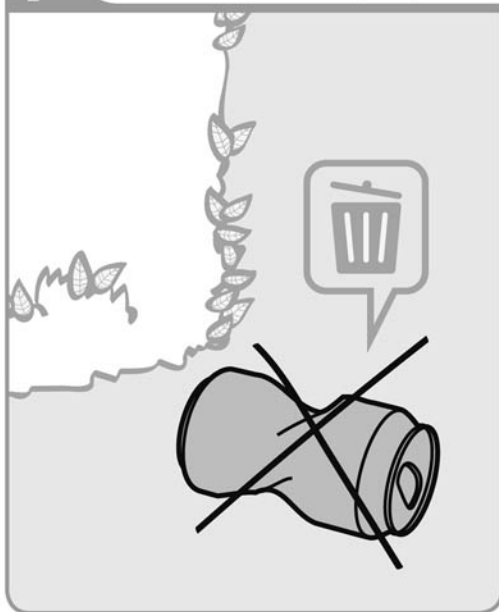

3

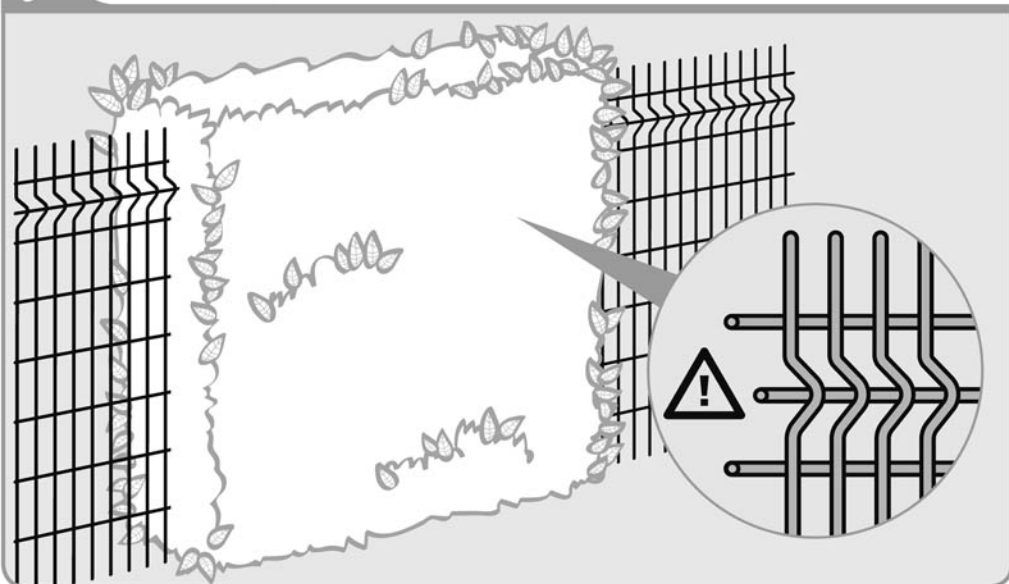

A

FR Préparation ES Preparación PT Preparação IT Preparazione EL Προετοιμασία PL Przygotowanie
UA Підготування RO Pregătire EN Preparation



4

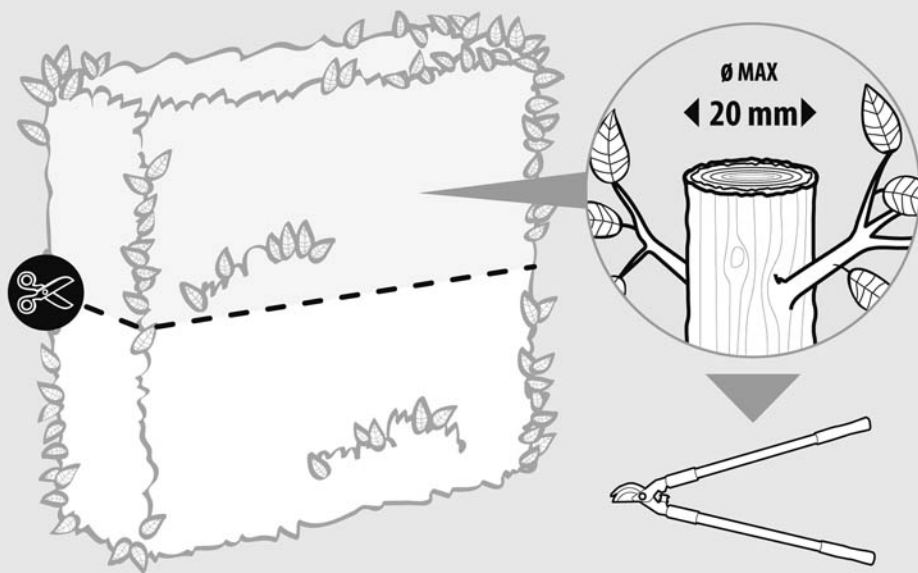

5

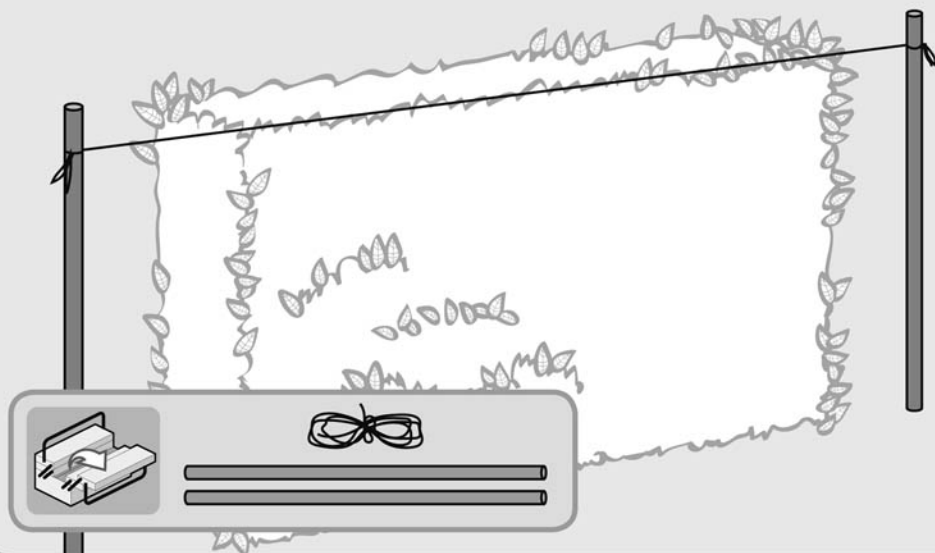

6

SP95

40:1

SP95	+	OIL2T
1L		25ml
2L		50ml
3L		75ml
4L		100ml
5L		125ml

OR

7

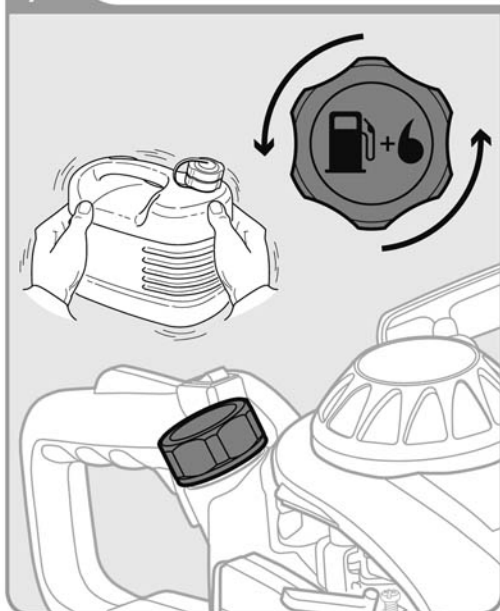

8

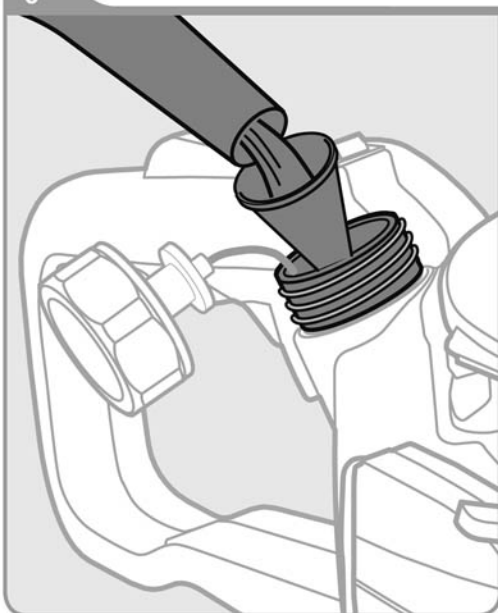

9

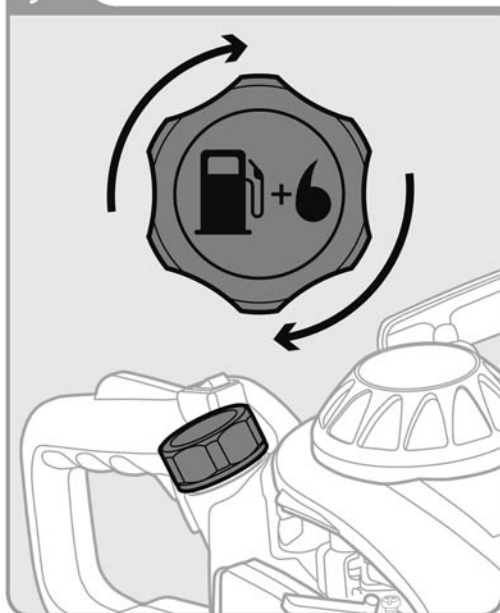

B1



FR Démarrage à froid

EL Εκκίνηση αυτοκινήτου στο κρύο

EN Cold start

ES Arranque en frío

PL Zimny rozruch

EN Cold start

PT Arranque a frio

UA Запуск холодного двигуна

IT Avvio a freddo

RO Pornire la rece

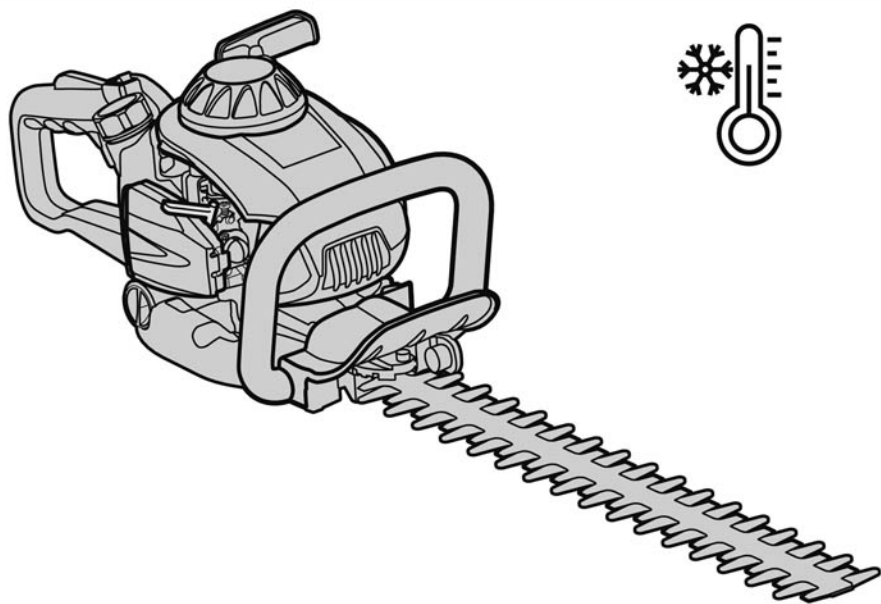

1



AUTOMATIC

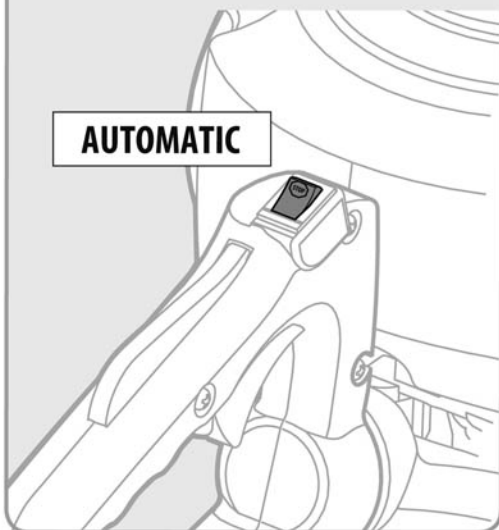

2

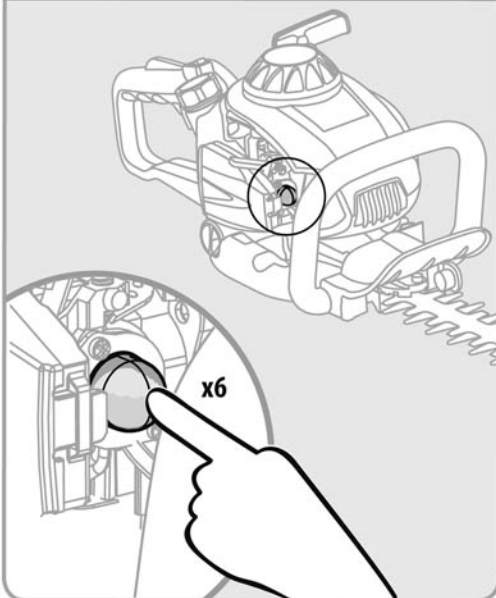



FR Démarrage à froid

EL Εκκίνηση αυτοκινήτου στο κρύο

EN Cold start

ES Arranque en frío

PL Zimny rozruch

PT Arranque a frio

UA Запуск холодного двигуна

IT Avvio a freddo

RO Pornire la rece

B1

3

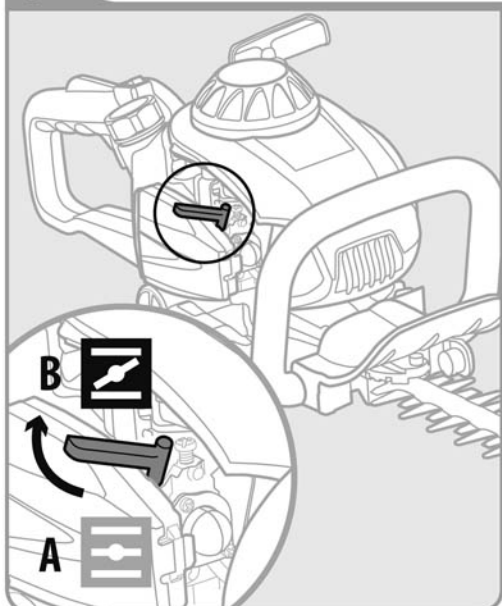

4

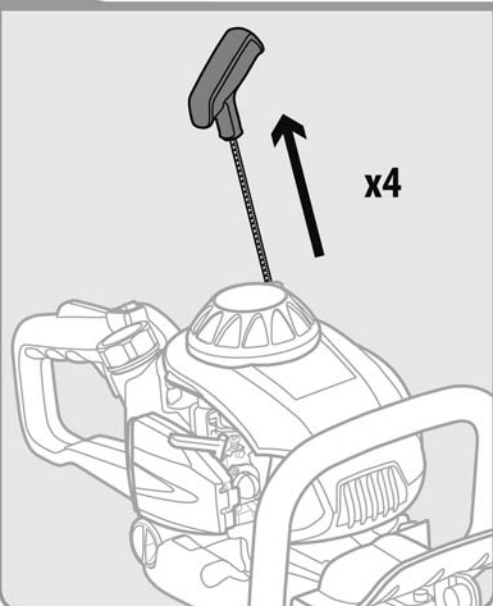

5

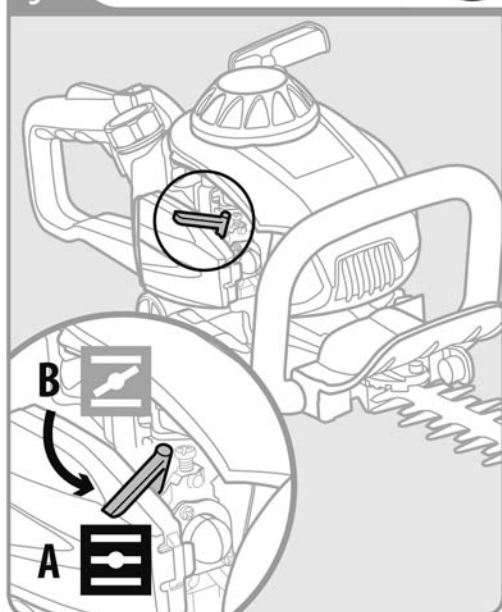

6

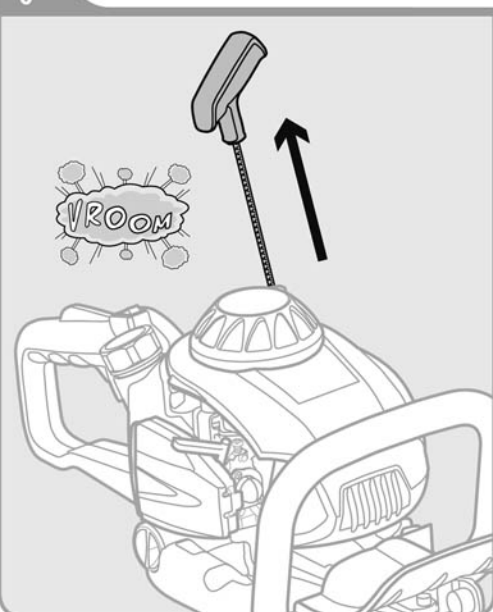

B1



FR Démarrage à froid

EL Εκκίνηση αυτοκινήτου στο κρύο

EN Cold start

ES Arranque en frío

PL Zimny rozruch

EN Cold start

PT Arranque a frio

UA Запуск холодного двигуна

IT Avvio a freddo

RO Pornire la rece

7

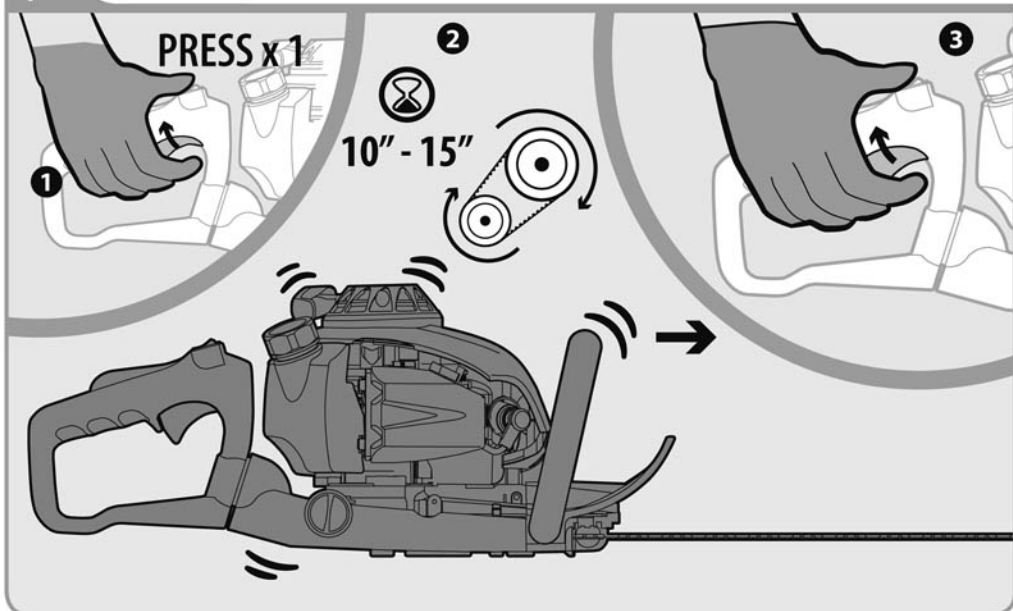



FR Démarrage à chaud

EL Εκκίνηση αυτοκινήτου στη ζέστη

EN Warm start

ES Arranque en caliente

PL Gorący rozruch

PT Arranque a quente

UA Запуск горячого двигуна

IT Avvio a caldo

RO Pornire la cald

B2

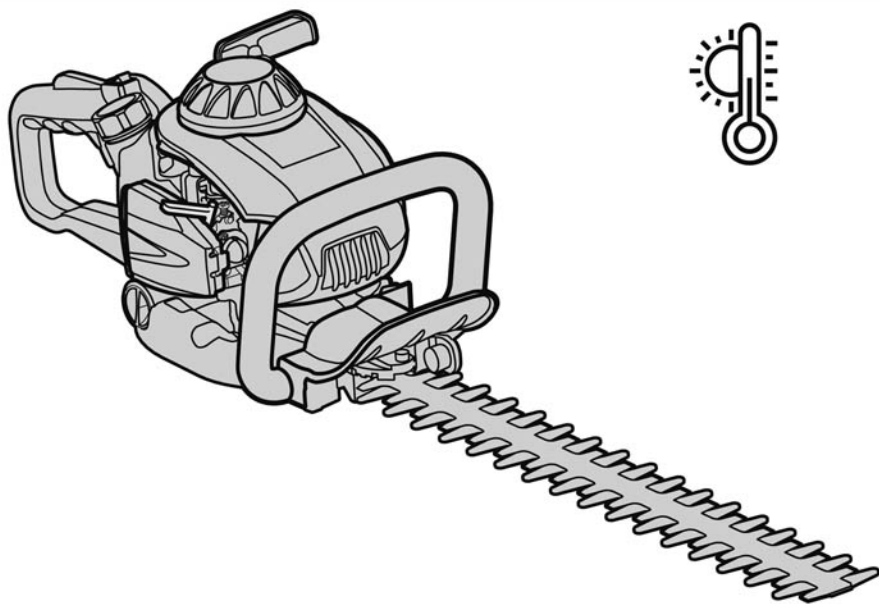

1



AUTOMATIC

2



x6

B2



FR Démarrage à chaud

EL Εκκίνηση αυτοκινήτου στη ζέστη

RO Pornire la cald

ES Arranque en caliente

PL Gorący rozruch

EN Warm start

PT Arranque a quente

UA Запуск гарячого двигуна

IT Avvio a caldo

3

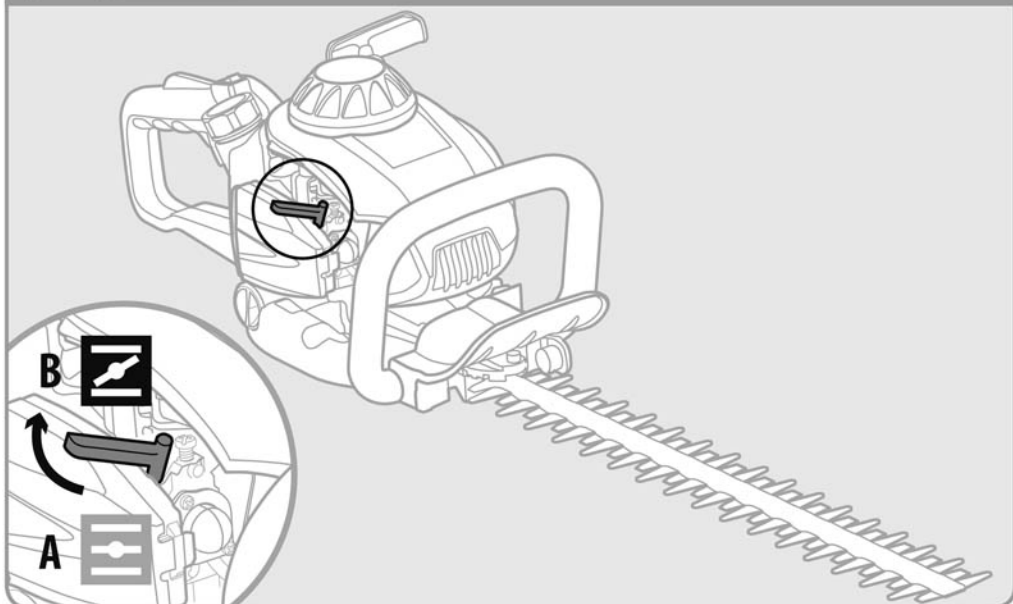

4

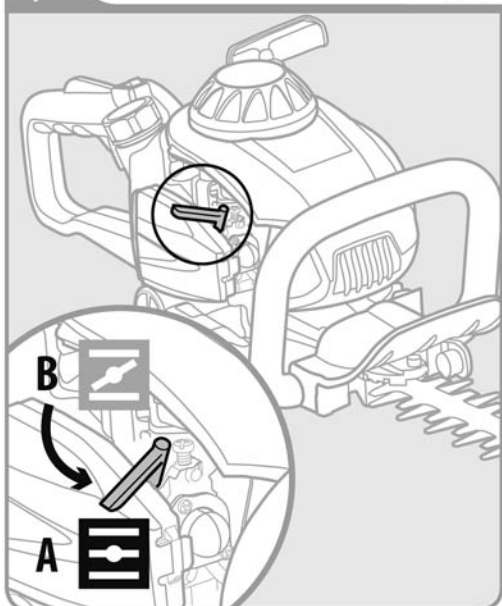

5

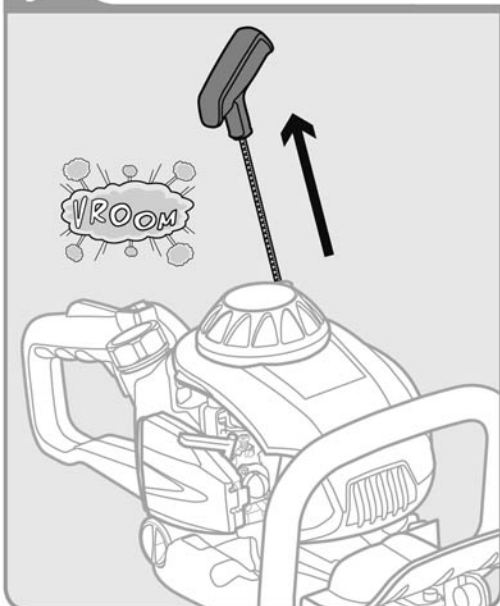



FR Démarrage à chaud

EL Εκκίνηση αυτοκινήτου στη ζέστη

EN Warm start

ES Arranque en caliente

PL Gorący rozruch

PT Arranque a quente

UA Запуск гарячого двигуна

IT Avvio a caldo

RO Pornire la cald

B2

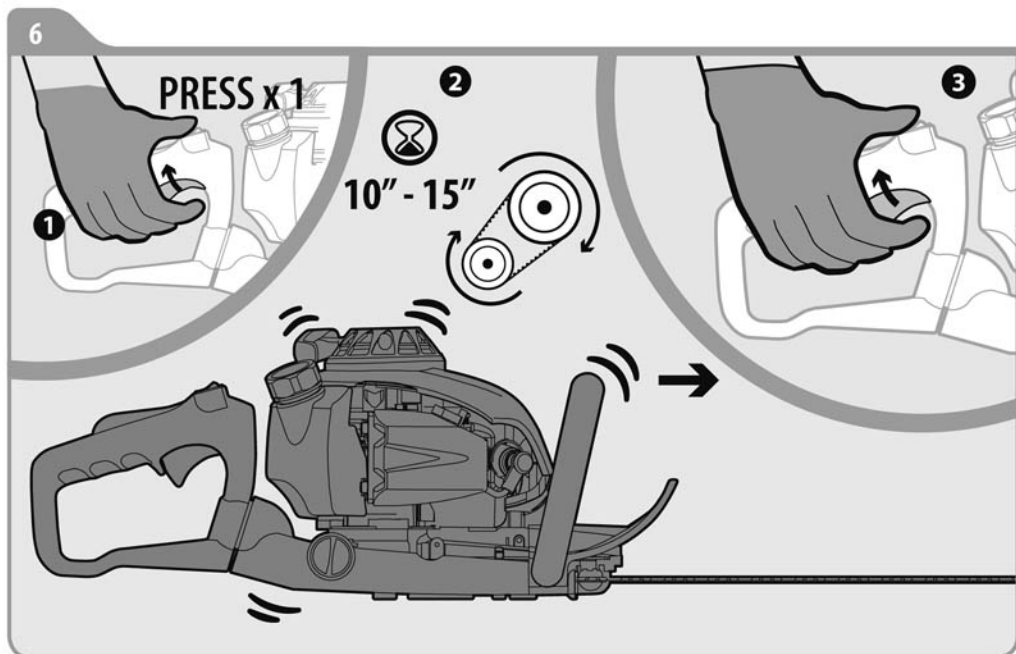

B3

FR Moteur noyé

EL Υπερχείλιση κινητήρα

EN Flooded engine

ES Motor ahogado

PL Zalany silnik

PT Motor afogado

UA Залитий двигун

IT Motore ingolfato

RO Motor înecat

1

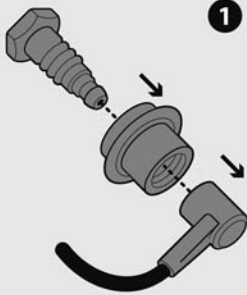

1



2

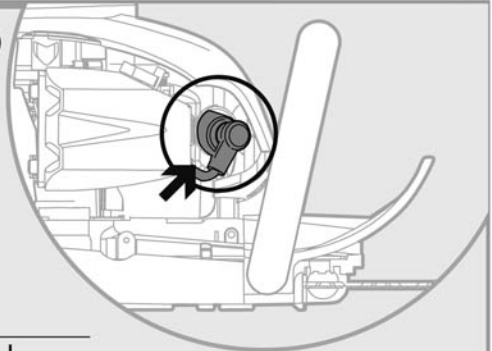

3

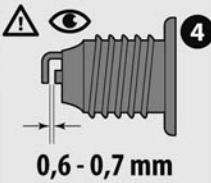

4

0,6 - 0,7 mm

5

6

7



PULL



19 mm

2

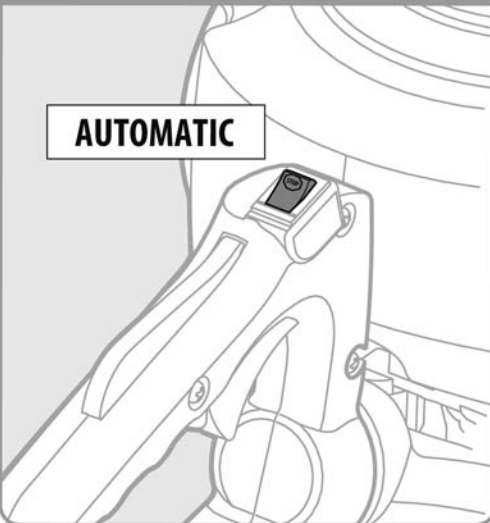
**AUTOMATIC**

3

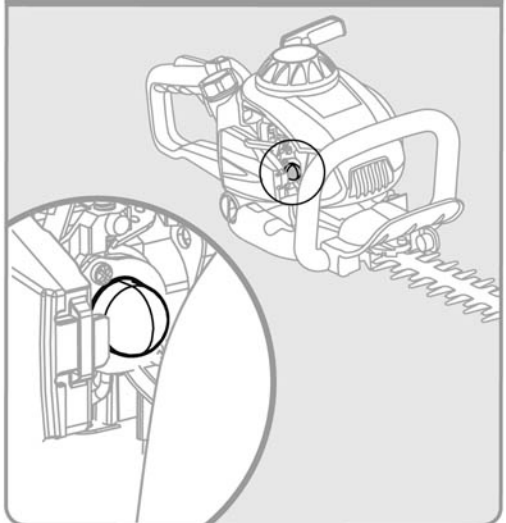



FR Moteur noyé

EL Υπερχείλιση κινητήρα

EN Flooded engine

ES Motor ahogado

PL Zalany silnik

PT Motor afogado

UA Залитий двигун

IT Motore ingolfato

RO Motor inecat

B3

4

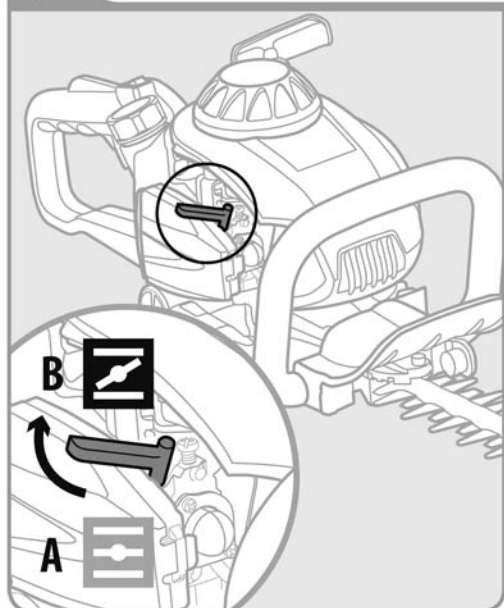

5

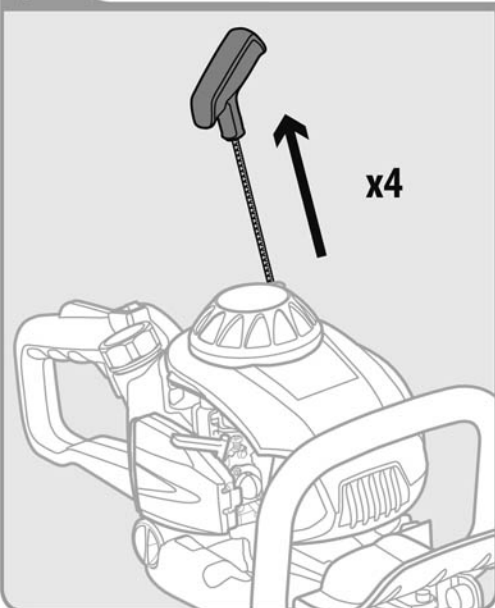

6

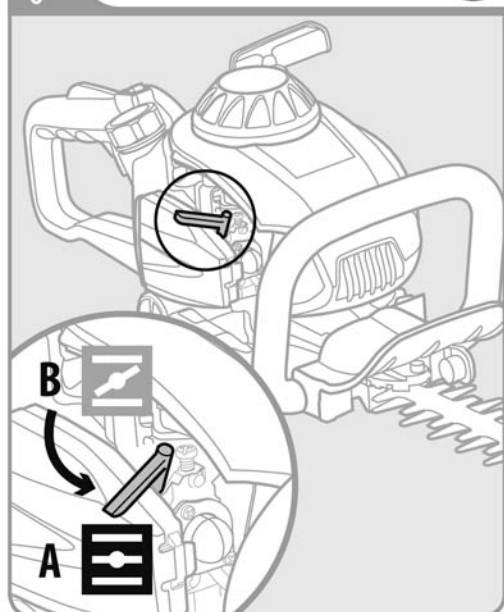

7

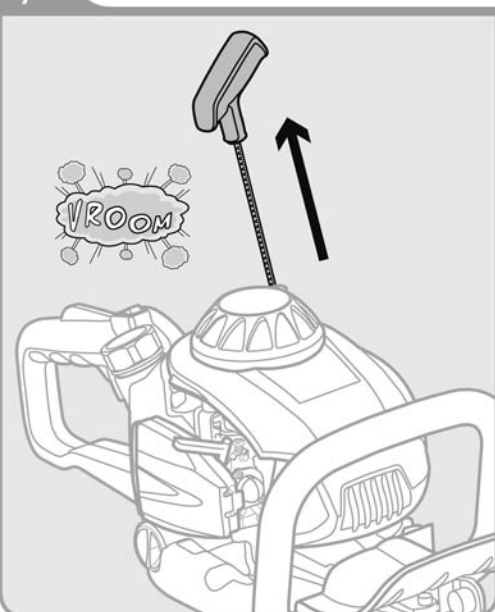

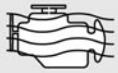
B3

FR Moteur noyé
EL Υπερχείλιση κινητήρα
EN Flooded engine

ES Motor ahogado
PL Zalany silnik

PT Motor afogado
UA Залитий двигун

IT Motore ingolfato
RO Motor înecat

8

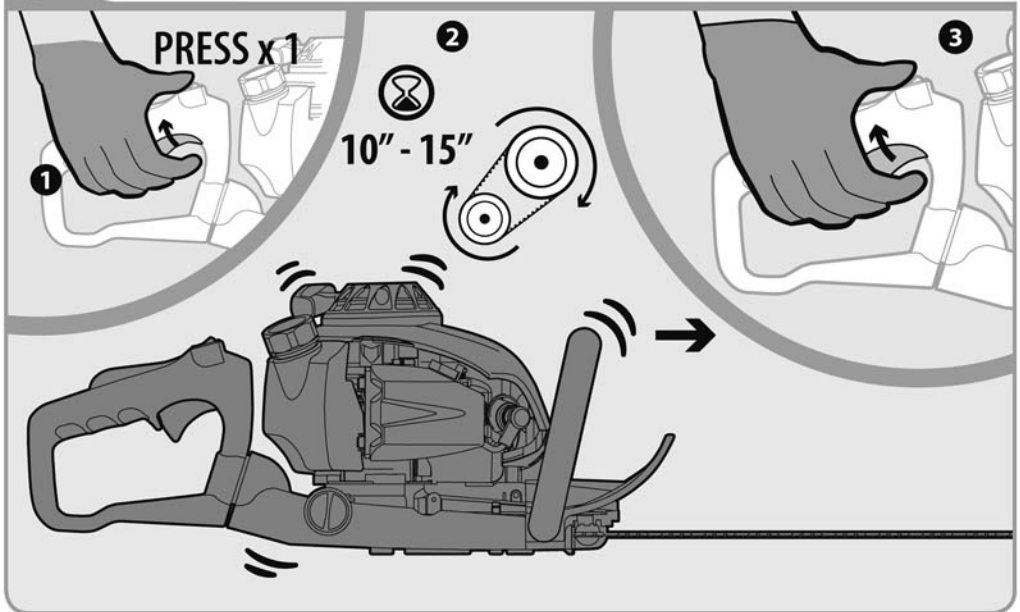

FR Utilisation

ES Utilización

PT Utilização

IT Uso

EL Χρήση

PL Użytkowanie

UA Використання

RO Utilizare

EN Use

C

1

Easy cut
Double blade

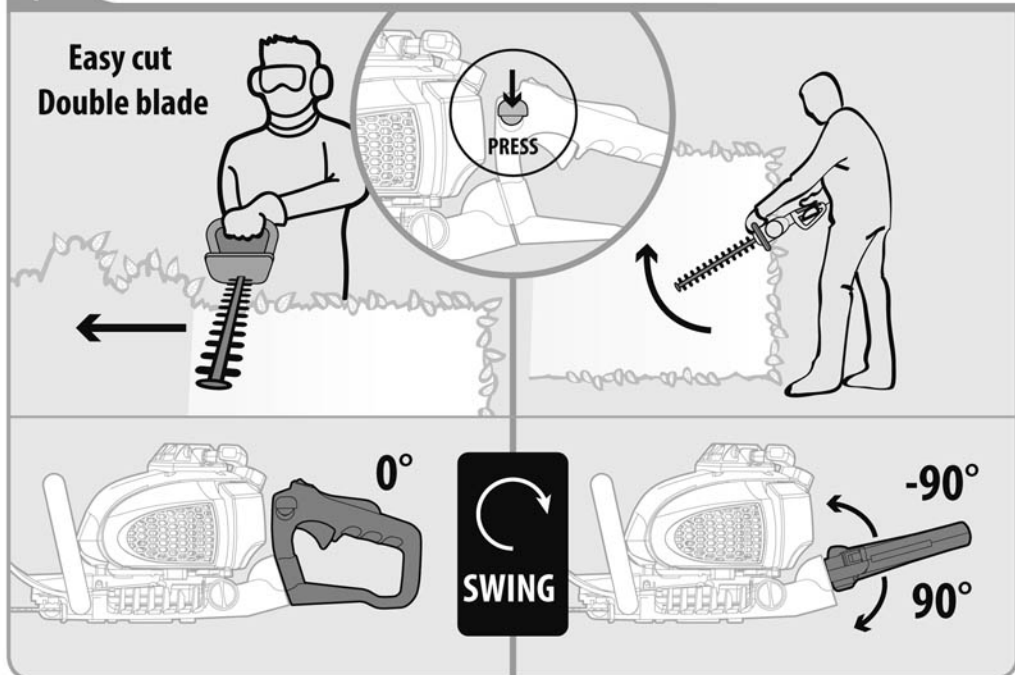

2

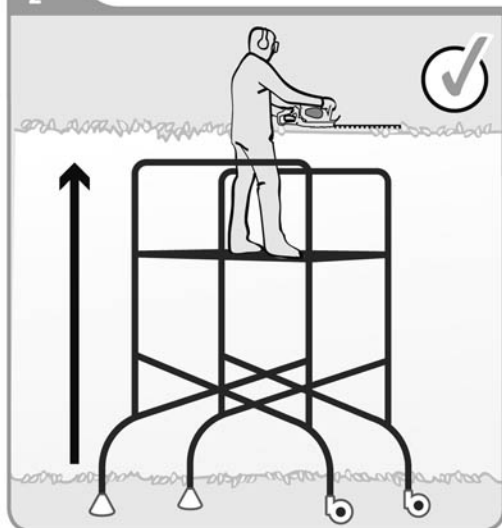

3

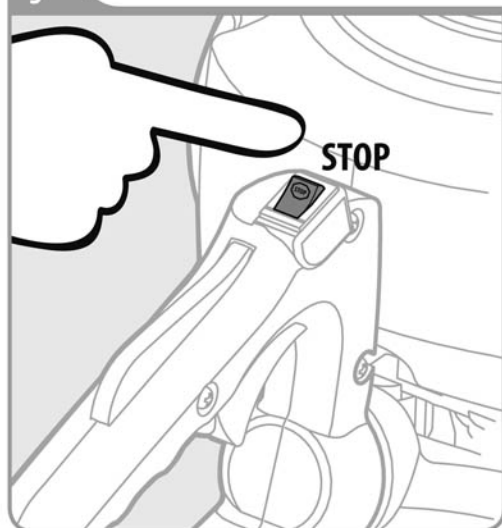

D

FR Entretien

ES Mantenimiento

PT Serviço

IT Manutenzione

EL Συντήρηση

PL Konserwacja

UA Догляд

RO Întreținere

EN Maintenance

1

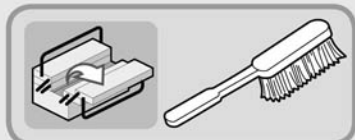
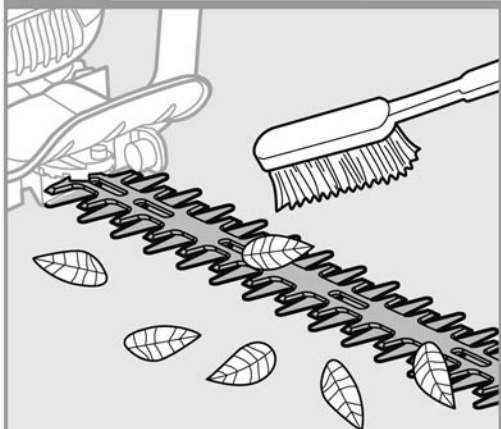

2



3

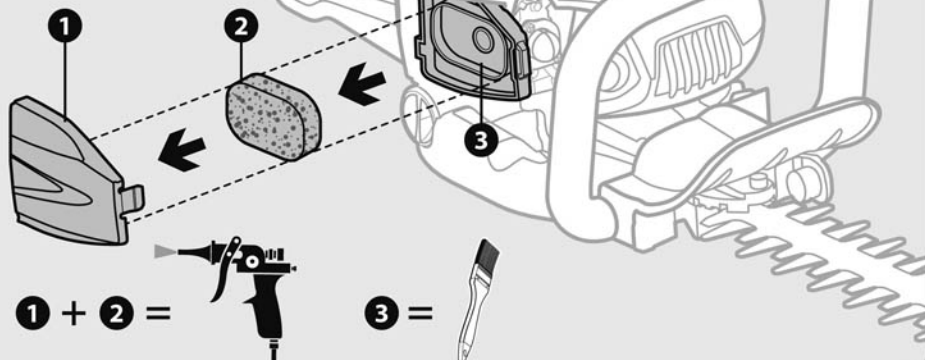

4

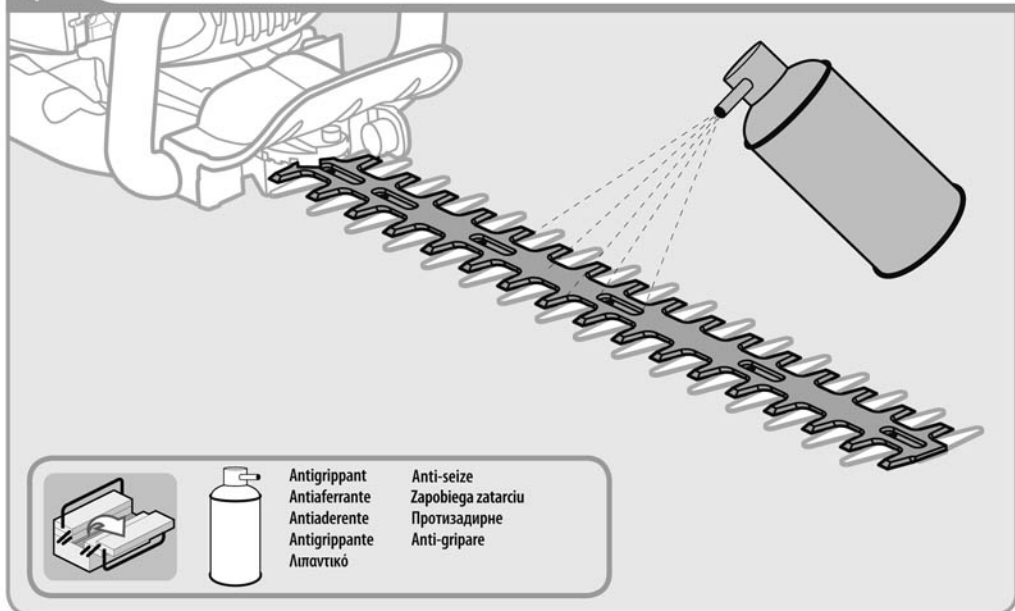

5

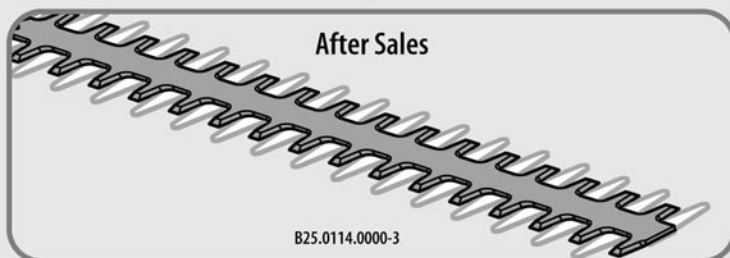
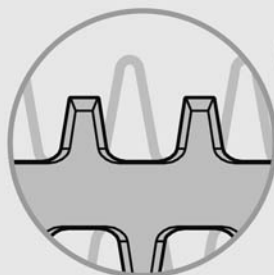

B25.0114.0000-3

D

FR Entretien

ES Mantenimiento

PT Serviço

IT Manutenzione

EL Συντήρηση

PL Konserwacja

UA Догляд

RO Întreținere

EN Maintenance

6

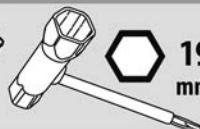
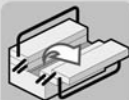
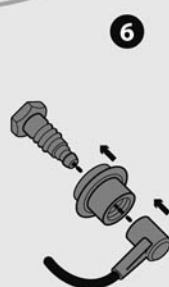
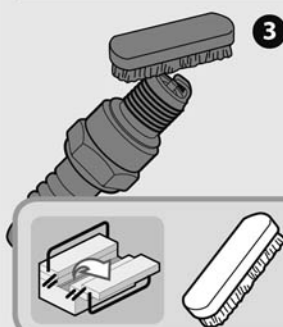
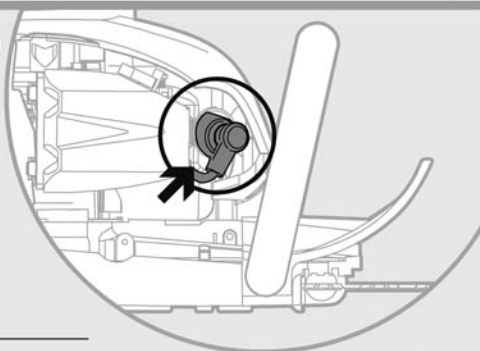
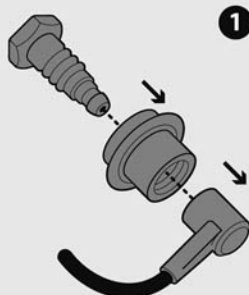
19
mm

7

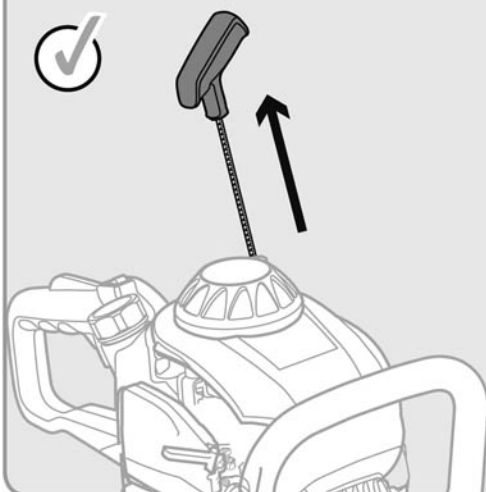

8

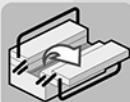
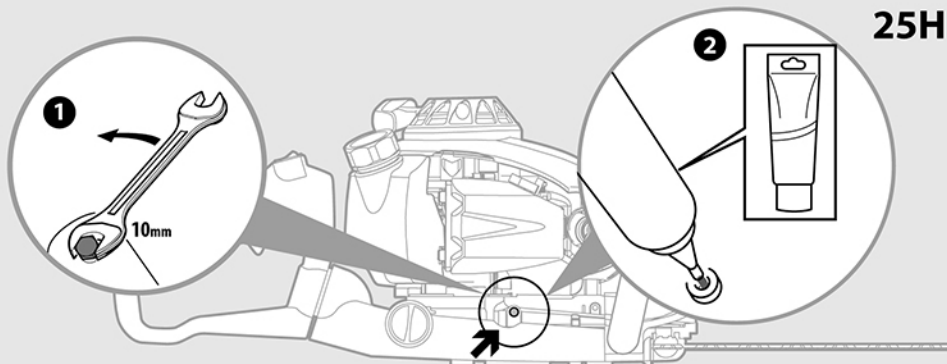

Graisse disponible en magasin
Grasa disponible en tienda
Lubrifiante disponibil na loja
Grasso disponibile in negozio
Γράσο διατίθεται στα ειδικά καταστήματα

Smaz dostępny w sklepie
Масило можна придбати в магазині
Unsoare disponibilă în magazine
Grease available in store

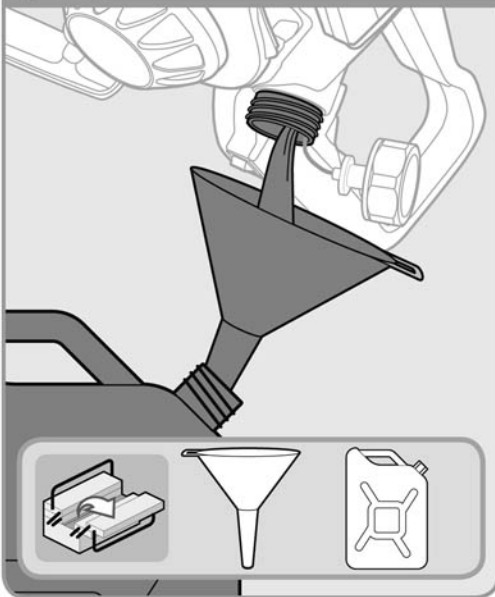
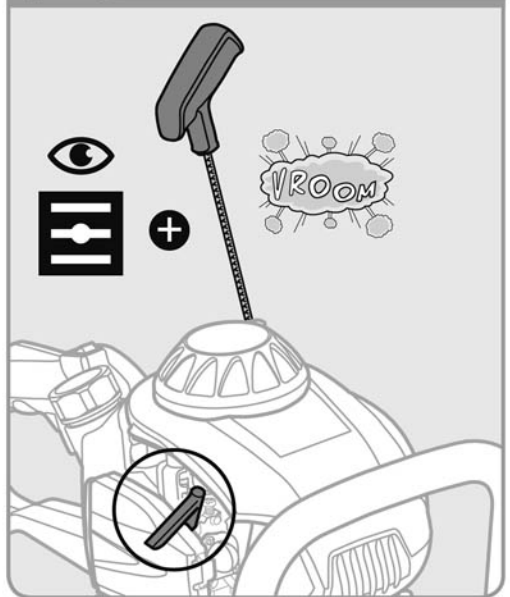
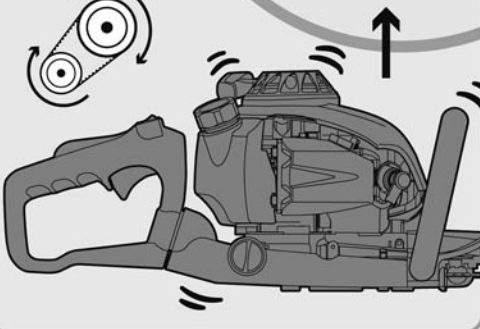
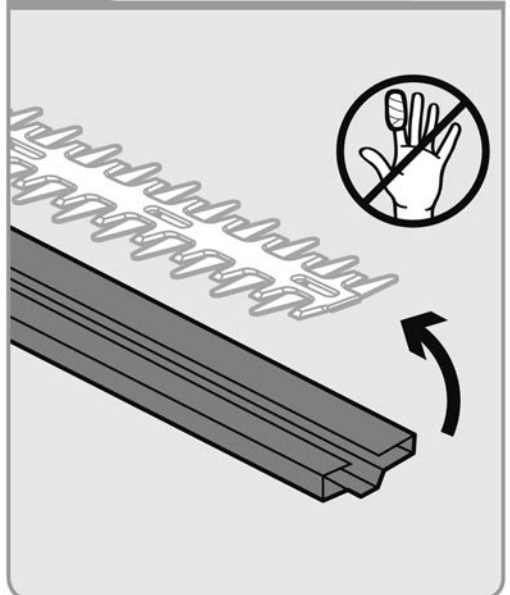

E**FR** Hivernage**EL** Αποθήκευση το χειμώνα**RO** Păstrare pe perioada iernii**ES** Durante el invierno**PL** Przechowywanie**EN** Winter storage**PT** Preparação para o inverno**UA** Зимовий період**IT** Rimessaggio**1****2****3****1****2****6" - 10"****4**

FR Hivernage

ES Durante el invierno

PT Preparação para o inverno

IT Rimessaggio

EL Αποθήκευση το χειμώνα

PL Przechowywanie

UA Зимовий період

RO Păstrare pe perioada iernii

EN Winter storage

E

5

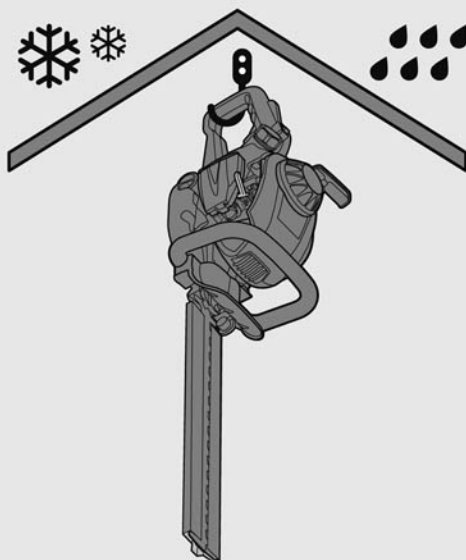



Ce produit se recycle,
s'il n'est plus utilisable
déposez-le en déchèterie.

Notice à trier.

Pour en savoir plus :

www.quefairedemesdechets.fr

- FR** Ce produit est recyclable. S'il ne peut plus être utilisé, veuillez l'apporter dans un centre de recyclage de déchets.
- ES** Este producto es reciclable. Si ya no se puede usar, llévalo a un centro de reciclaje de residuos.
- PT** Este produto é reciclável. Se deixar de o utilizar, entregue-o num centro de reciclagem de resíduos.
- IT** Questo prodotto può essere riciclato. Se deve essere smaltito, portalo presso un centro di riciclaggio.
- EL** Αυτό το προϊόν είναι ανακυκλώσιμο. Εάν δεν μπορεί πλέον να χρησιμοποιηθεί, μεταφέρετε την σε κάποιο κέντρο ανακύκλωσης απορριμμάτων.
- PL** Ten produkt poddawany jest recyklingowi, kiedy przestaje być użyteczny należy dostarczyć go do punktu zbiórki odpadów.
- UA** Цей продукт може перероблятися. Якщо воно більше не є придатне для використання, здайте його в утилізаційний центр.
- RO** Acest produs este reciclabil. Dacă nu mai poate fi folosit, vă rugăm să îl aduceți într-un centru de reciclare a deșeurilor.
- EN** This product is recyclable. If it cannot be used anymore, please take it to waste recycling centre.



Made in China



* Garantie 3 ans / 3 años de garantía / Garantia de 3 anos / Garanzia 3 anni /
Εγγύηση 3 ετών / Gwarancja 3-letnia / Гарантія 3 років / Garanție 3 ani /
3-year guarantee



Adeo Services - 135, rue Sadi Carnot - CS 00001 59790 - RONCHIN - France

ТОВ «Леруа Мерлен Україна»,
вул. Полярна 17а, м. Київ 04201, Україна

Imported by Adeo South Africa (PTY) LTD T/A Leroy
Merlin Leroy Merlin Greenstone Store Corner Blackrock
Street and Stoneridge Drive, Greenstone Park Ext 2,
Edenvale, 1610 Johannesburg, Gauteng, South Africa