

ESSENTIAL

- FR** Nous vous remercions d'avoir acheté ce produit. Nous vous conseillons de lire attentivement la notice d'installation, d'utilisation et d'entretien. Nous avons conçu ce produit pour vous apporter entière satisfaction. Si vous avez besoin d'aide l'équipe de votre magasin est à votre disposition pour vous accompagner.
- ES** Le agradecemos haber comprado este producto. Le recomendamos leer atentamente el manual de instalación, uso y mantenimiento. Este producto ha sido diseñado para proporcionarle plena satisfacción. Si necesita alguna ayuda, el personal de la tienda estará a su disposición para guiarle.
- PT** Agradecemos a sua preferência por este produto . Aconselhamo-lo a ler o manual de instalação, utilização e manutenção com atenção. Criámos este produto para sua completa satisfação. Se precisar de ajuda, a equipa da sua loja está à sua disposição para o acompanhar.
- IT** Grazie per aver acquistato questo prodotto. Vi raccomandiamo di leggere attentamente il manuale di installazione, utilizzo e manutenzione. Questo prodotto è stato progettato per offrirvi la massima soddisfazione. Per ricevere assistenza, il personale del punto vendita è a vostra disposizione.
- EL** Ευχαριστούμε για την αγορά σας αυτού του προϊόντος. Σας συμβουλεύουμε να διαβάσετε προσεκτικά τις οδηγίες εγκατάστασης, χρήσης και συντήρησης. Σχεδιάσαμε αυτό το προϊόν για να σας προσφέρει πλήρη ικανοποίηση. Αν χρειάζεστε βοήθεια, η ομάδα του καταστήματος από το οποίο αγοράσατε το προϊόν είναι στη διάθεσή σας.
- PL** Dziękujemy za zakup produktu firmy. Zalecamy, aby uważanie przeczytać instrukcję instalacji, użytkowania i konserwacji. Ten produkt marki zaprojektowaliśmy, aby spełnić wszystkie państwa oczekiwania. W razie potrzeby pracownicy sklepu służą Państwu pomocą i są do Państwa dyspozycji.
- UA** Дякуємо за придбання цього продукту. Ми рекомендуємо вам уважно прочитати інструкції зі встановлення, використання та обслуговування. Ми розробили цей продукт, щоб забезпечити ваше повне задоволення. Якщо вам потрібна допомога, команда вашого продавця завжди готова допомогти вам.
- RO** Vă mulțumim pentru achiziționarea acestui produs. Vă sfatuim să citiți cu atenție instrucțiunile de instalare, de utilizare și de întreținere. Am conceput acest produs pentru a vă furniza satisfacție totală. Dacă aveți nevoie de ajutor, echipa magazinului de cumpărare este la dispoziția dumneavoastră pentru a vă asista.
- BR** Obrigado por ter adquirido um produto . Nós aconselhamos a ler atentamente o manual de instalação, uso e manutenção. Concebemos um produto para proporcionar total satisfação. Caso precise de ajuda, a equipe da sua loja estará à disposição para te acompanhar.
- EN** Thank you for purchasing this product. We recommend that you read the installation, user and maintenance instructions carefully. We have designed this product to ensure your complete satisfaction. If you require assistance, the team at your retailer is on hand to help you.

FR Plan de la notice **ES** Esquema del folleto **PT** Plano de instruções
IT Piano delle istruzioni **EL** Σχέδιο οδηγιών **PL** Plan instrukcji
RO Planul instrucțiunilor **BR** Esboço do folheto **UA** Огляд посібника
EN Overview of the guide

01

FR : Matériel - ES : Material - PT : Material - IT : Materiale - EL : Υλικό
PL : Material - UA : Матеріал - RO : Material - BR : Material -
EN : Equipment



02

FR : Préparation - ES : Preparación - PT : Preparação - IT : Preparazione
EL : Προετοιμασία - PL : Przygotowanie - UA : Підготовка -
RO : Pregătire - BR : Preparação - EN : Preparation



03

FR : Montage - ES : Montaje - PT : Montagem - IT : Montaggio
EL : Συναρμολόγηση - PL : Montaz - UA : Збірка - RO : Montaj -
BR : Montagem - EN : Assembly



04

FR : Entretien - ES : Mantenimiento - PT : Manutenção - IT : Manutenzione
EL : Συντήρηση - PL : Konserwacja - UA : Технічне обслуговування -
RO : Întreținere - BR : Manutenção - EN : Maintenance



05

FR : Documents - ES : Documentos - PT : Documentos - IT : Documenti
EL : Έγγραφα - PL : Dokumenty - UA : Документи - RO : Documente -
BR : Documentos - EN : Documents



FR IMPORTANT,
à conserver pour
consultation ultérieure :
à lire attentivement

ES IMPORTANTE,
conservar para consultar
posteriormente :
leer atentamente

PT IMPORTANTE,
conservar para futuras
consultas : por favor,
leia com atenção

IT IMPORTANTE,
da conservare per
ulteriore consultazione :
da leggere attentamente

EL ΣΗΜΑΝΤΙΚΟ,
κρατήστε το για
μελλοντική αναφορά.
Διαβάστε το προσεκτικά

PL WAŻNE,
do zachowania na
przyszłość: proszę
przeczytać uważnie

UA ВАЖЛИВО,
щоб бути зберегти на
майбутнє посилання:
будь ласка уважно
прочитайте

RO IMPORTANT,
a se pastra pentru
consultarea ulterioara:
citiți cu atenție

BR IMPORTANTE,
por favor manter para
referência futura:
leia com atenção.

EN IMPORTANT,
to be retained for
future reference:
please read carefully.

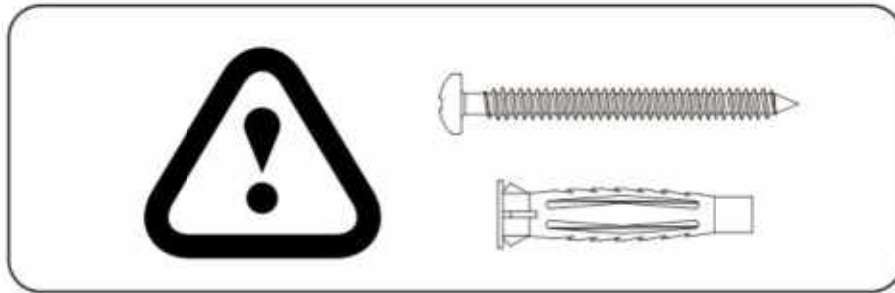

- FR** Vérifiez que les chevilles murales fournis sont appropriées à votre mur (celles fournis dans l'emballage sont conçues pour le béton). Sinon, utilisez des vis et des chevilles murales adaptées au type de matériau de votre mur. Pour obtenir des conseils concernant les vis et les chevilles appropriées à votre mur, demandez à un vendeur spécialisé.
- ES** Asegúrese de que los tacos de pared proporcionados son adecuados para su pared (los proporcionados en el paquete están diseñados para hormigón). De lo contrario, utilice tornillos y tacos de pared adecuados al tipo de material de su pared. Para obtener consejos sobre los tornillos y tacos adecuados para su pared, pregunte a un vendedor especializado.
- PT** Verifique se as cavilhas de parede fornecidas são adequadas para sua parede (as fornecidas na embalagem são projetadas para concreto). Caso contrário, use parafusos e buchas de parede adequadas para o tipo de material da sua parede. Para obter conselhos sobre os parafusos e buchas adequados para a sua parede, pergunte a um vendedor especializado.
- IT** Verifica che i tasselli a muro forniti siano adatti alla tua parete (quelli forniti nella confezione sono progettati per il calcestruzzo). Altrimenti, utilizzare viti e tasselli a muro adatti al tipo di materiale della parete. Per consigli su viti e tasselli adatti alla tua parete, chiedi a un venditore specializzato.
- EL** Βεβαιωθείτε ότι οι άγκυρες τοίχων που παρέχονται είναι κατάλληλες για τον τοίχο σας (εκείνες που παρέχονται στη συσκευασία). Εάν όχι, χρησιμοποιήστε βίδες και άγκυρες τοίχων που προσαρμόζονται στον τύπο του υλικού στον τοίχο σας. Για συμβουλές σχετικά με τις κατάλληλες βίδες και πείρους για τον τοίχο σας, ρωτήστε έναν εξειδικευμένο πωλητή.
- PL** Sprawdź, czy dostarczone kotwice ścienne są odpowiednie dla twojej ściany (te dostarczone w opakowaniu są przeznaczone do betonu). Jeśli nie, użyj śrub i kotew ściennych dostosowanych do rodzaju materiału na ścianie. Aby uzyskać porady dotyczące odpowiednich śrub i kołków do ściany, poproś wyspecjalizowanego sprzedawcę.
- UA** Переконайтеся, що надані настінні анкери підходять для вашої стіни (ті, що передбачені в упаковці, призначені для бетону). Якщо ні, використовуйте шурупи і настінні анкери, пристосовані до типу матеріалу на вашій стіні. За порадою щодо правильних саморізів і дюбелів для вашої стіни зверніться до спеціалізованого продавця.
- RO** Verificați dacă ancorele de perete furnizate sunt potrivite pentru peretele dumneavoastră (cele prevăzute în pachet sunt proiectate pentru beton). Dacă nu, utilizați șuruburi și ancore de perete adaptate tipului de material de pe perete. Pentru sfaturi privind șuruburile și diblurile adecvate pentru peretele dvs., adresați-vă unui vânzător specializat.
- BR** Verifique se as buchas fornecidas são adequadas para a sua parede (as fornecidas no pacote são projetadas para concreto). Caso contrário, use parafusos e buchas adaptados ao tipo de material de sua parede. Para obter orientação sobre os parafusos e buchas corretos para a sua parede, consulte um revendedor especializado.
- EN** Check that the supplied wall anchors are suitable for your wall (those provided in the package are for concrete). Otherwise, use screws and wall anchors adapted to the type of material on your wall. For advice on screws and fittings suitable for your wall, ask a specialized seller for advice.

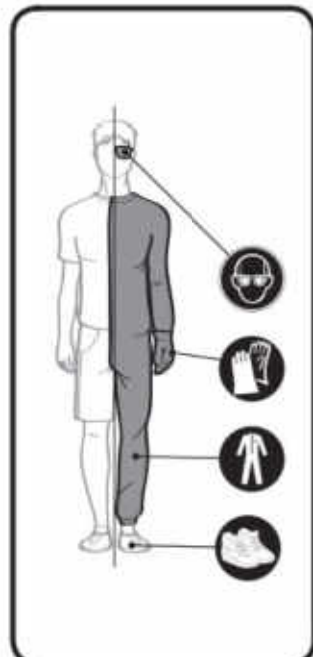
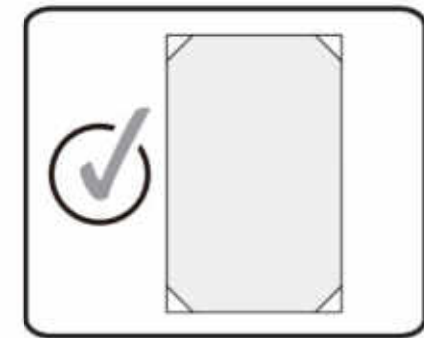
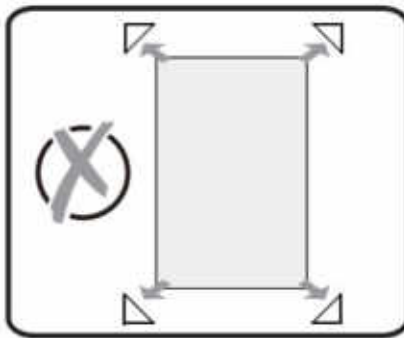
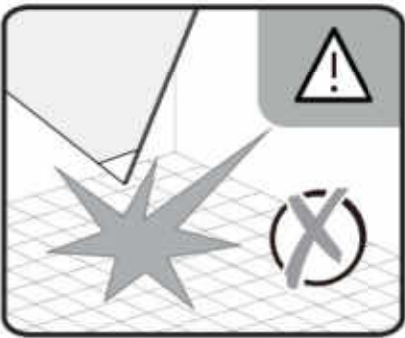
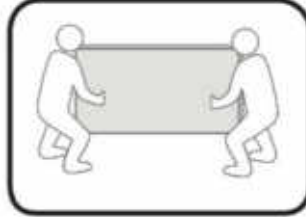
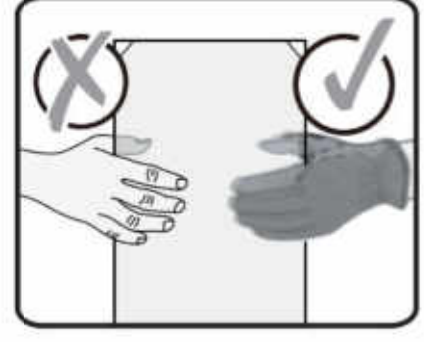
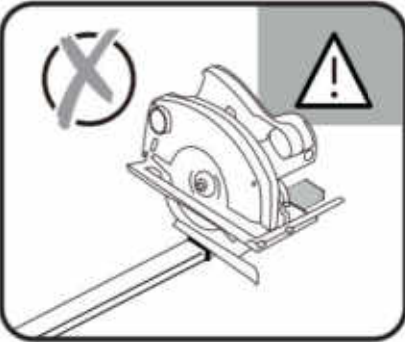
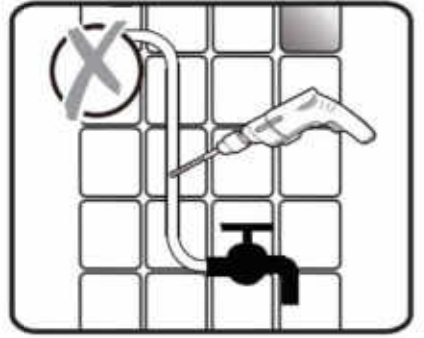
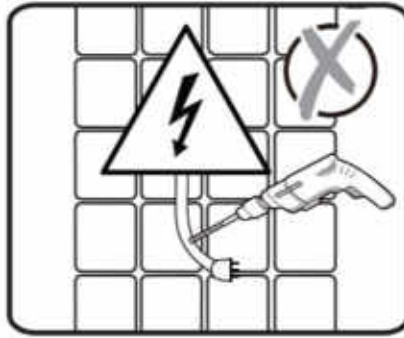
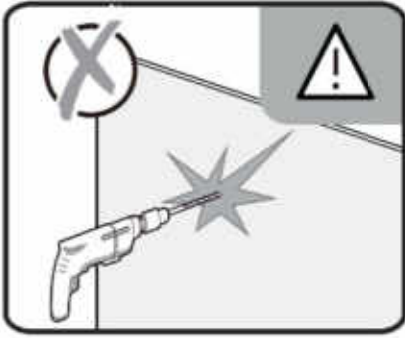

01

FR Matériel
IT Materiale
UA Матеріал
EN Equipment

ES Material
EL Υλικό
RO Material

PT Material
PL Material
BR Material



01

FR Matériel
IT Materiale
UA Матеріал
EN Equipment

ES Material
EL Υλικό
RO Material

PT Material
PL Materiał
BR Material

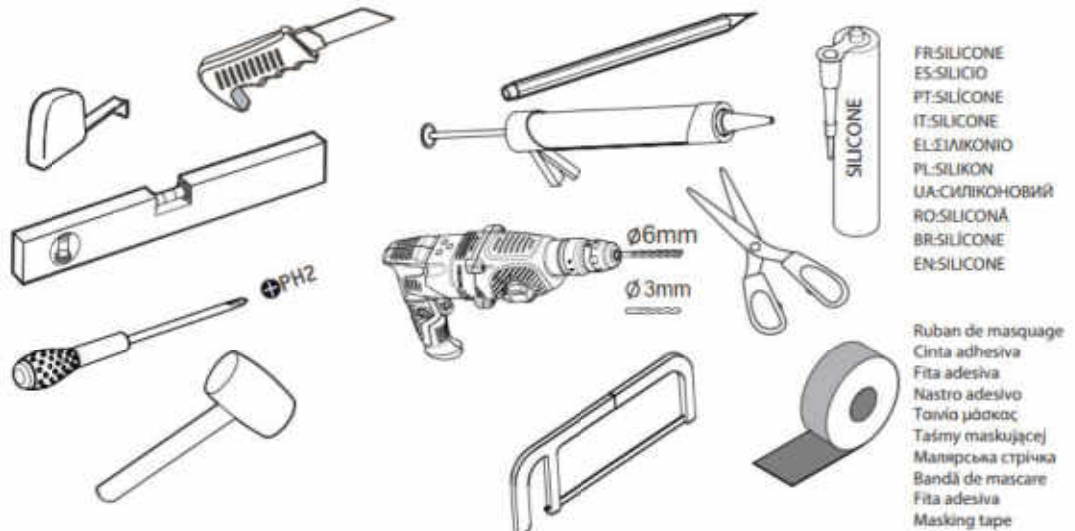
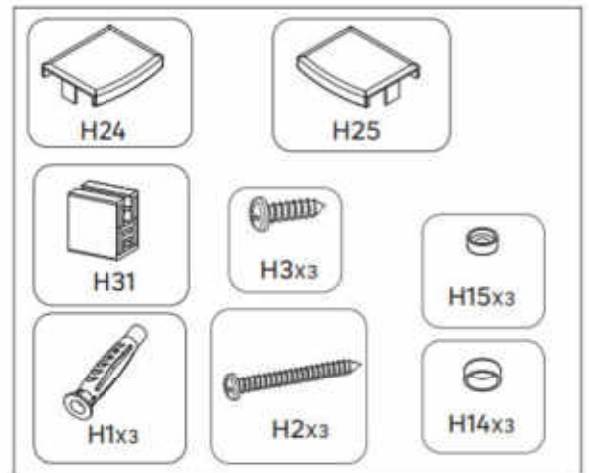
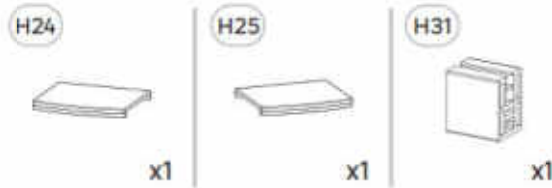

02

FR Préparation
IT Preparazione
UA Підготовка
EN Preparation

ES Preparación
EL Προετοιμασία
RO Pregătire

PT Preparação
PL Przygotowanie
BR Preparação

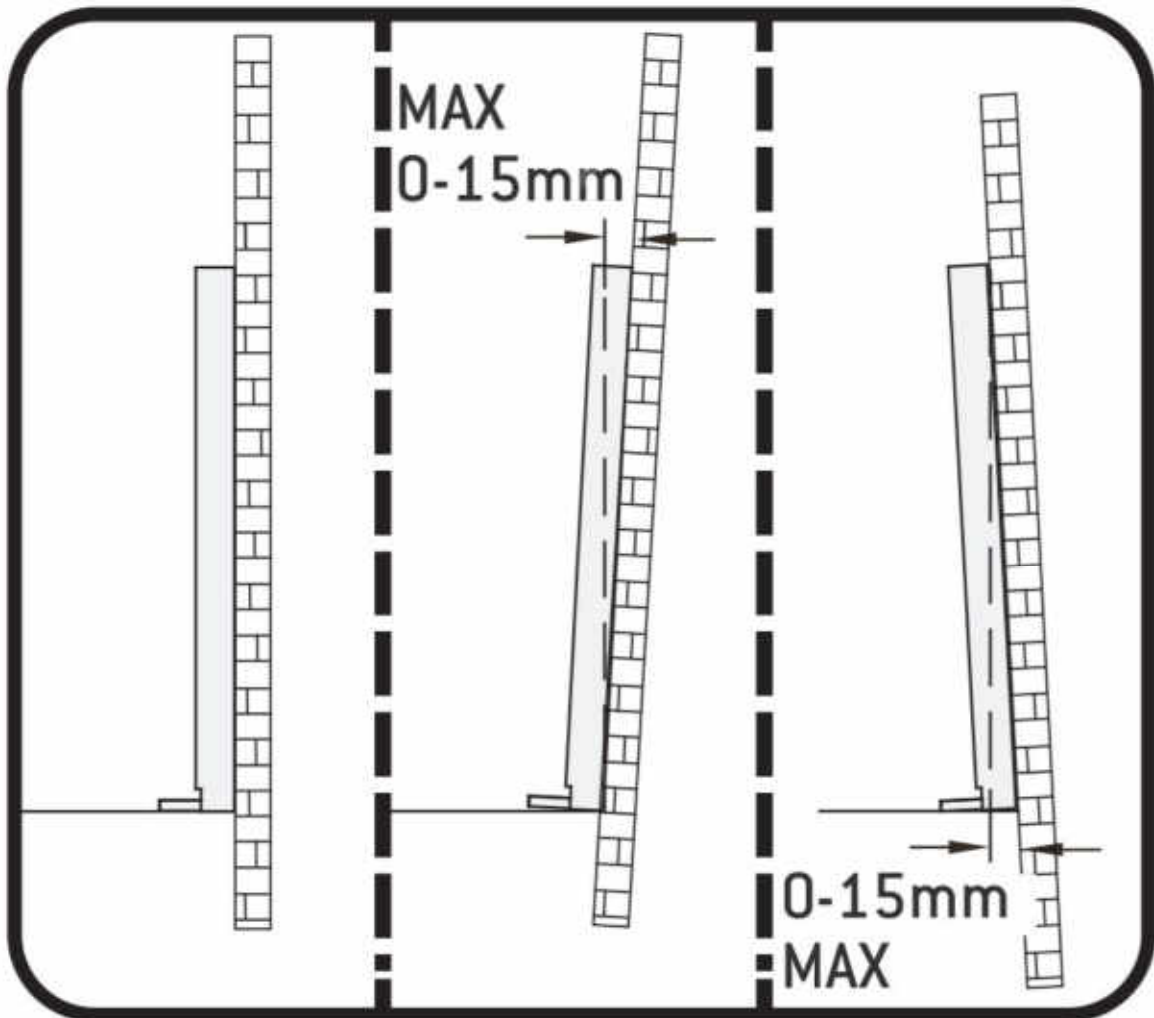

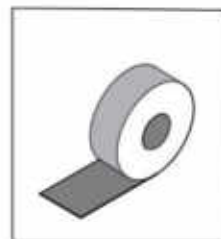
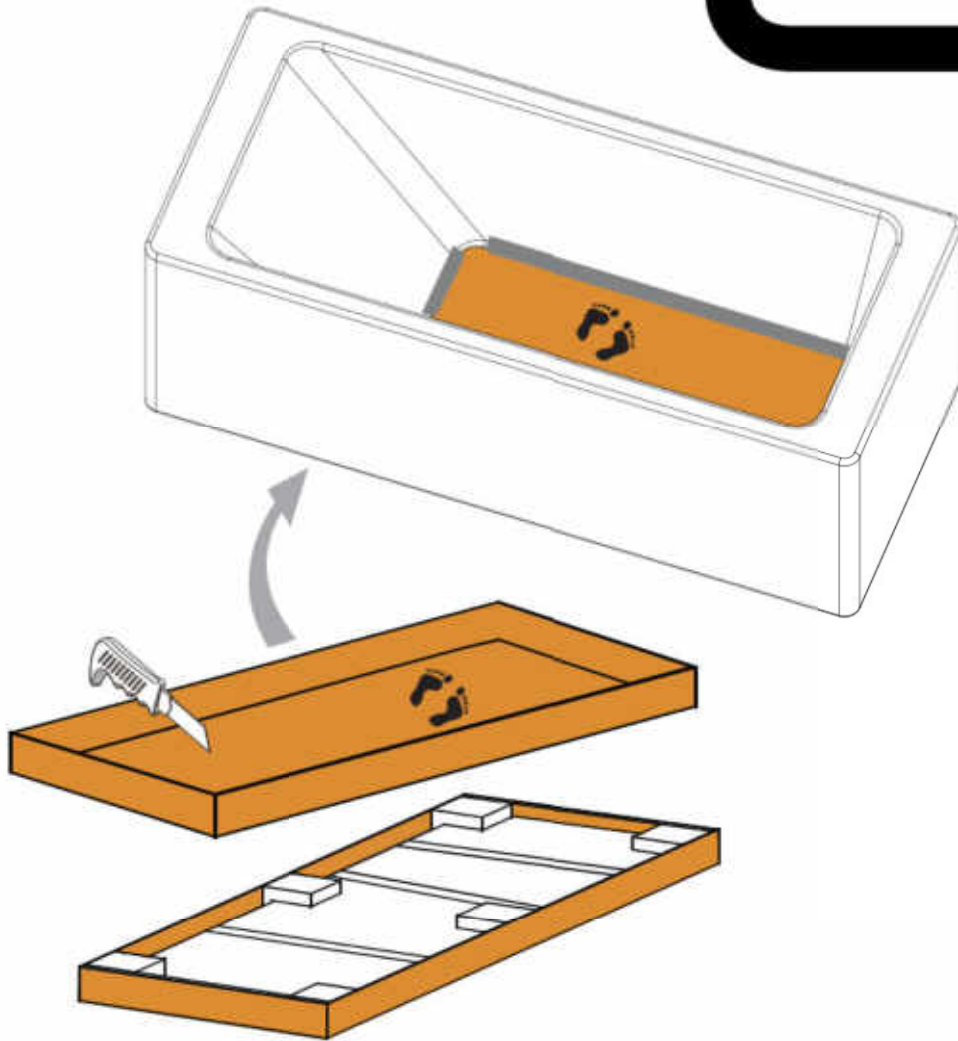

Ruban de masquage
Cinta adhesiva
Fita adesiva
Nastro adesivo
Ταινία μόνωσης
Таśmy maskujacej
Малярська стрічка
Bandă de mascare
Fita adesiva
Masking tape

03

FR Montage
IT Montaggio
UA Збірка
EN Assembly

ES Montaje
EL Συναρμολόγηση
RO Montaj

PT Montagem
PL Montaż
BR Montagem

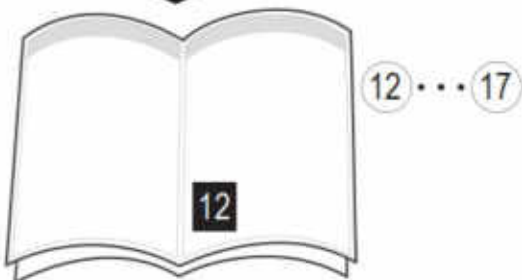
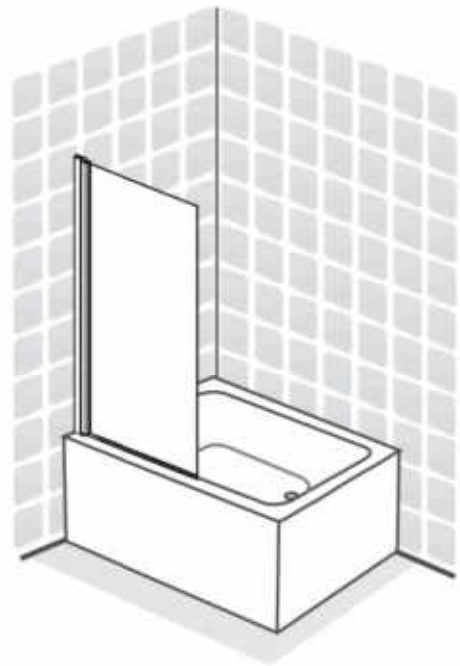
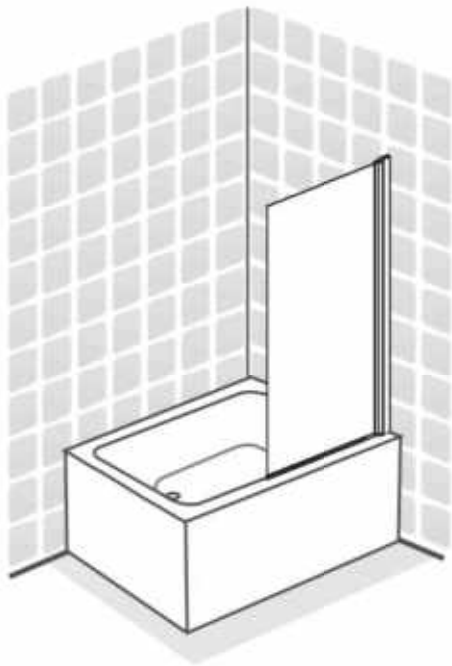

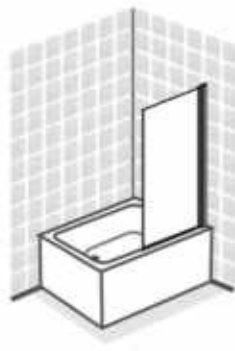

1.

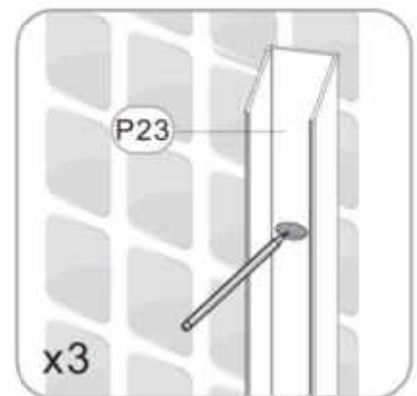
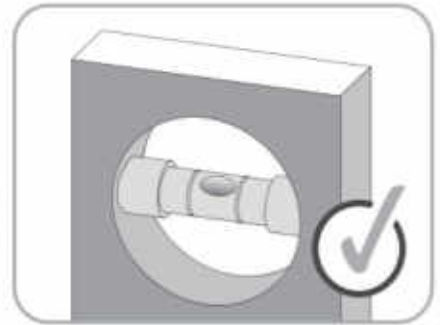
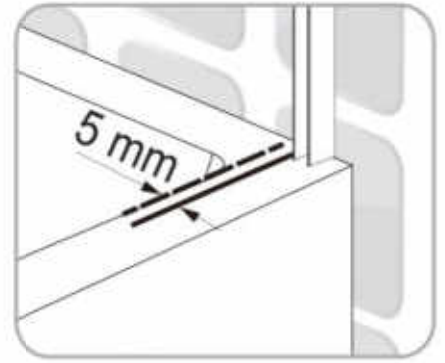
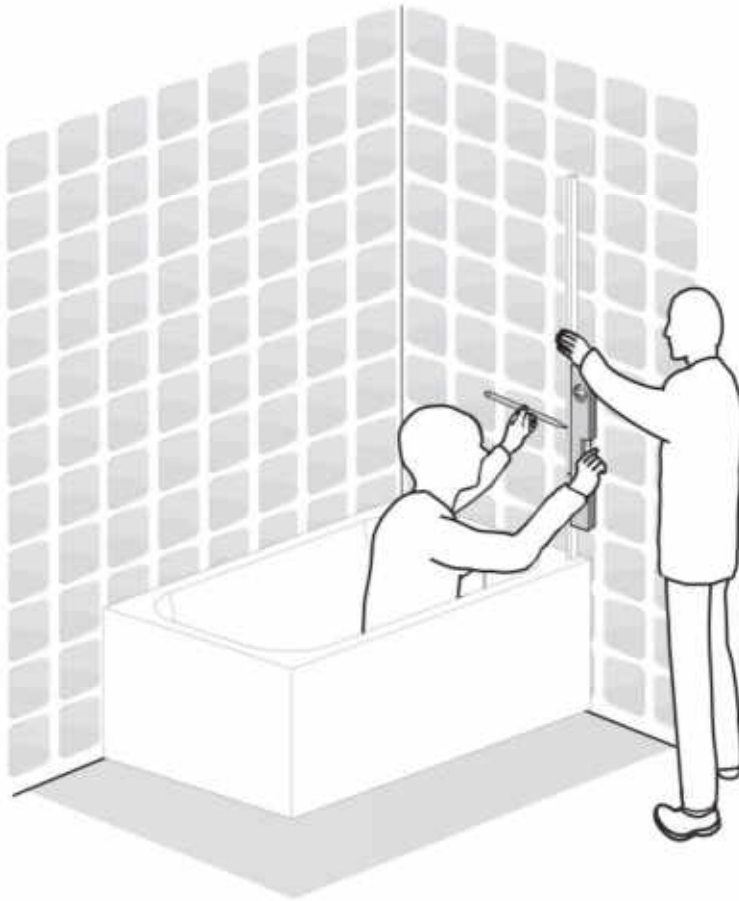

2.

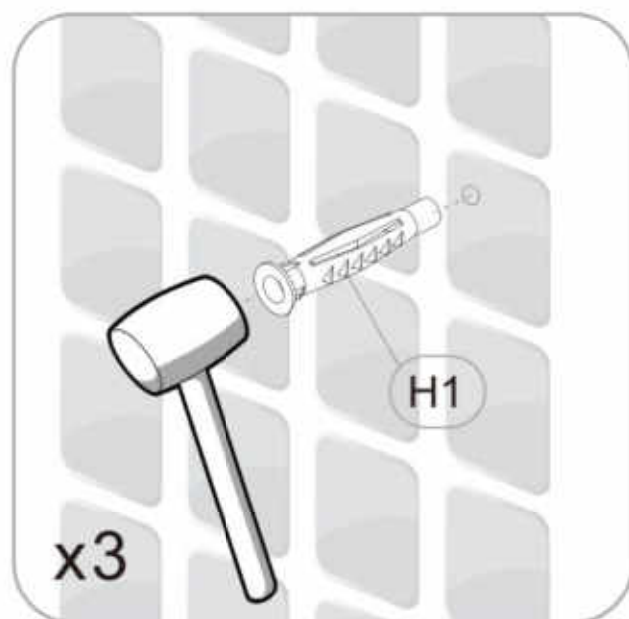
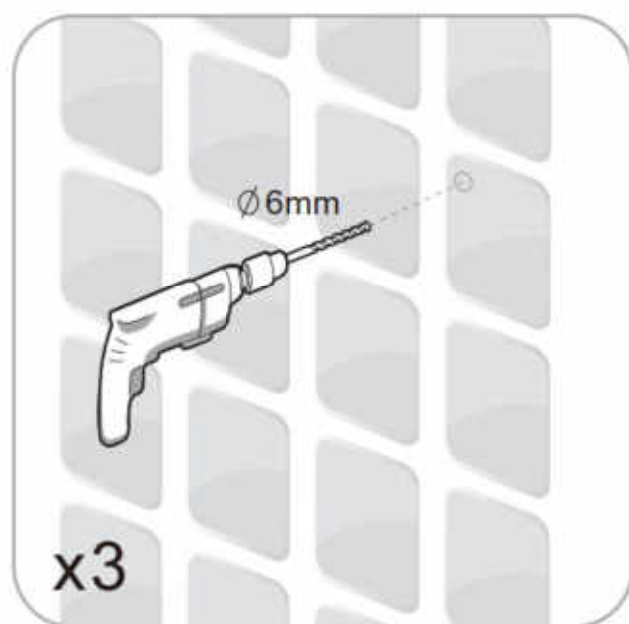
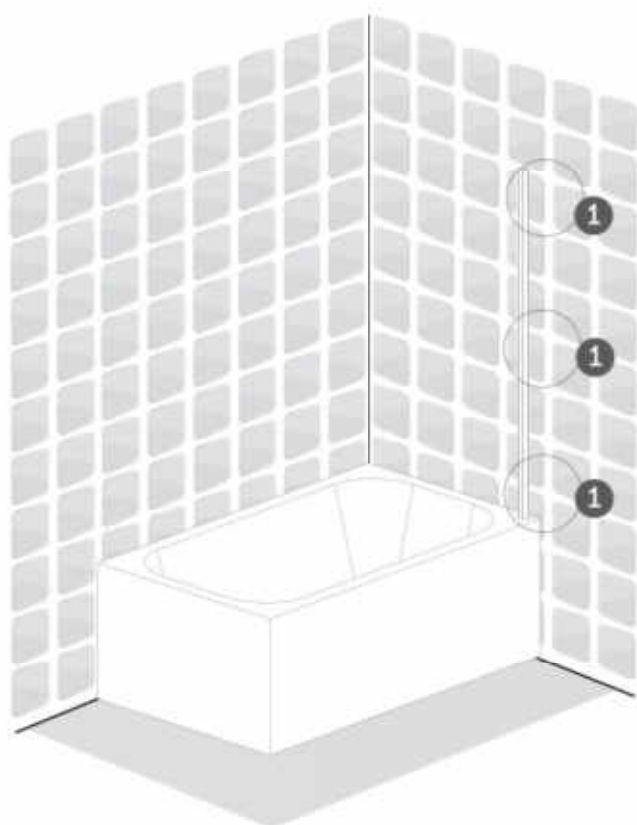
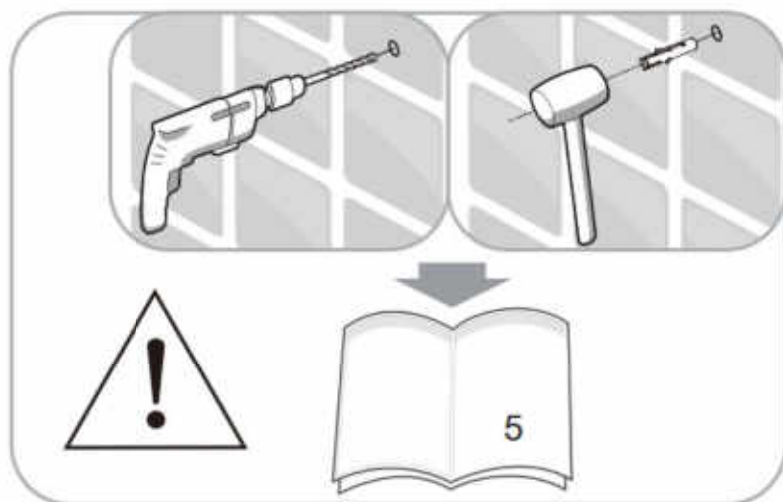

3.

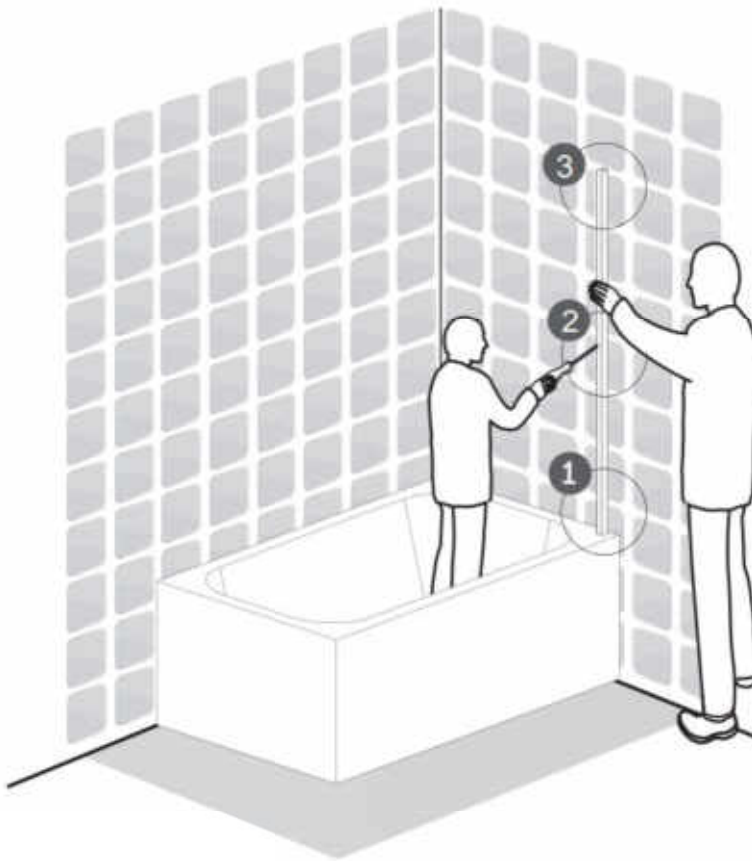
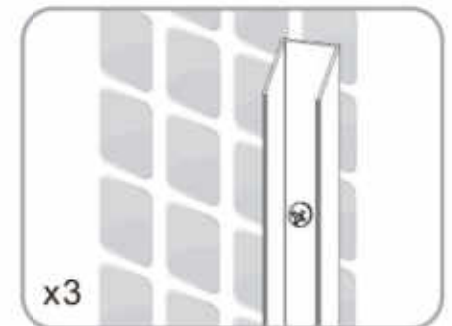
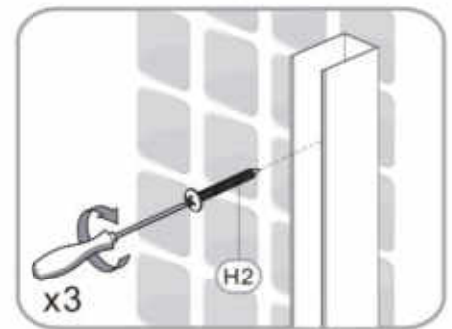
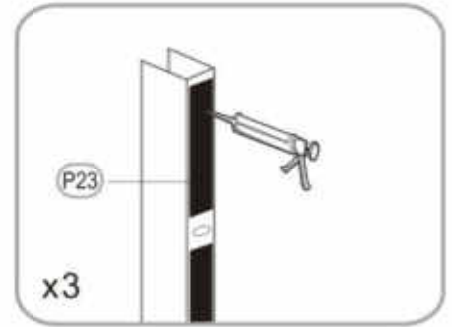

4.

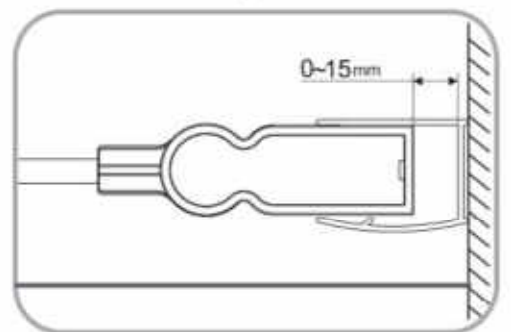
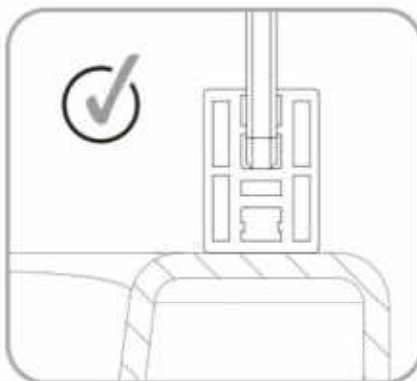
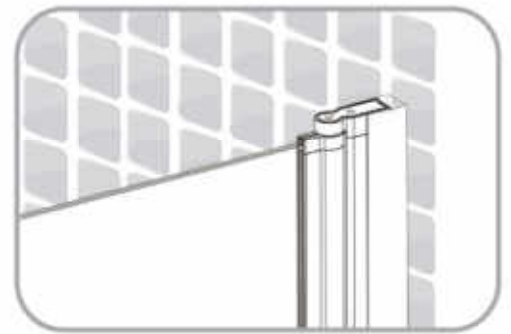
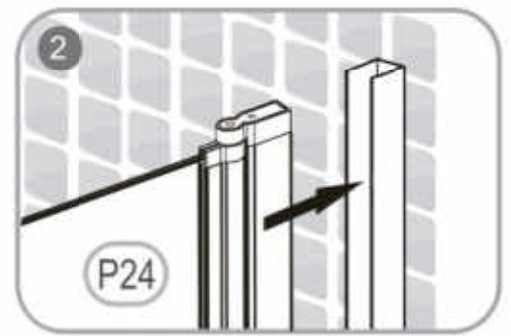
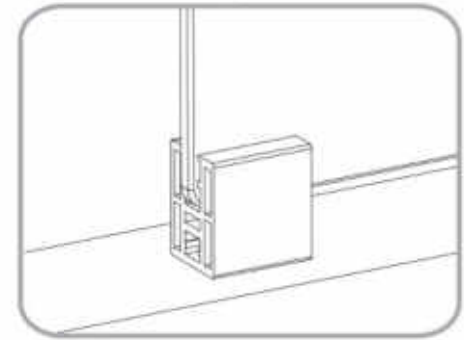
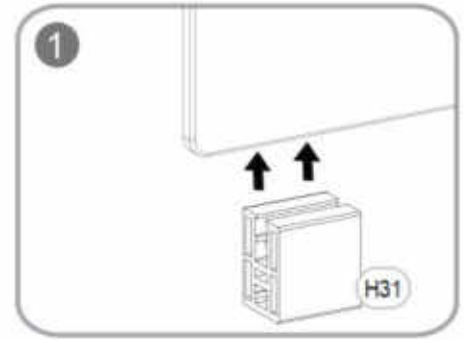
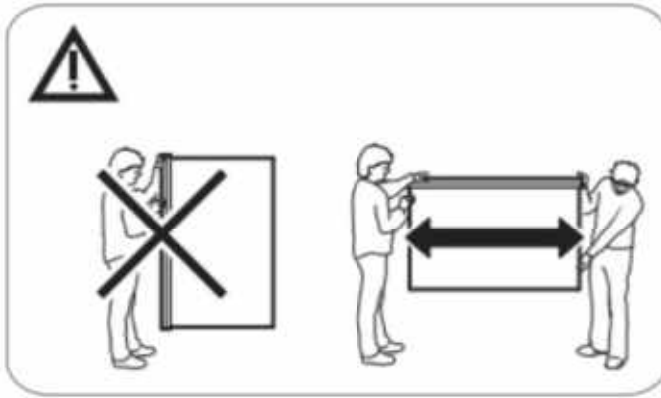

5.

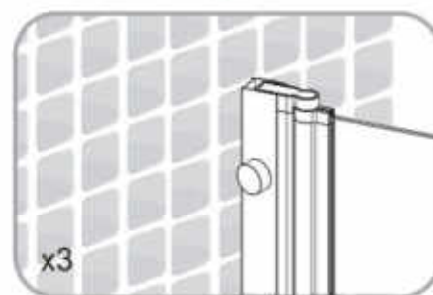
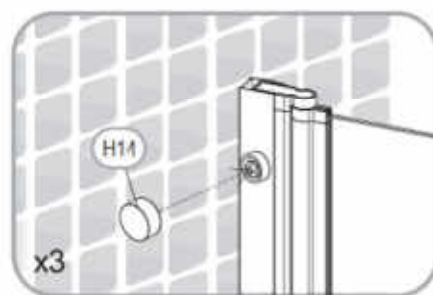
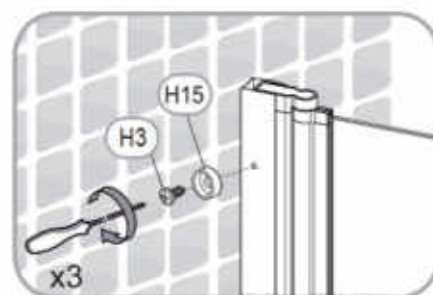
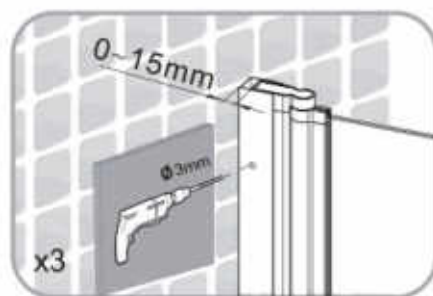
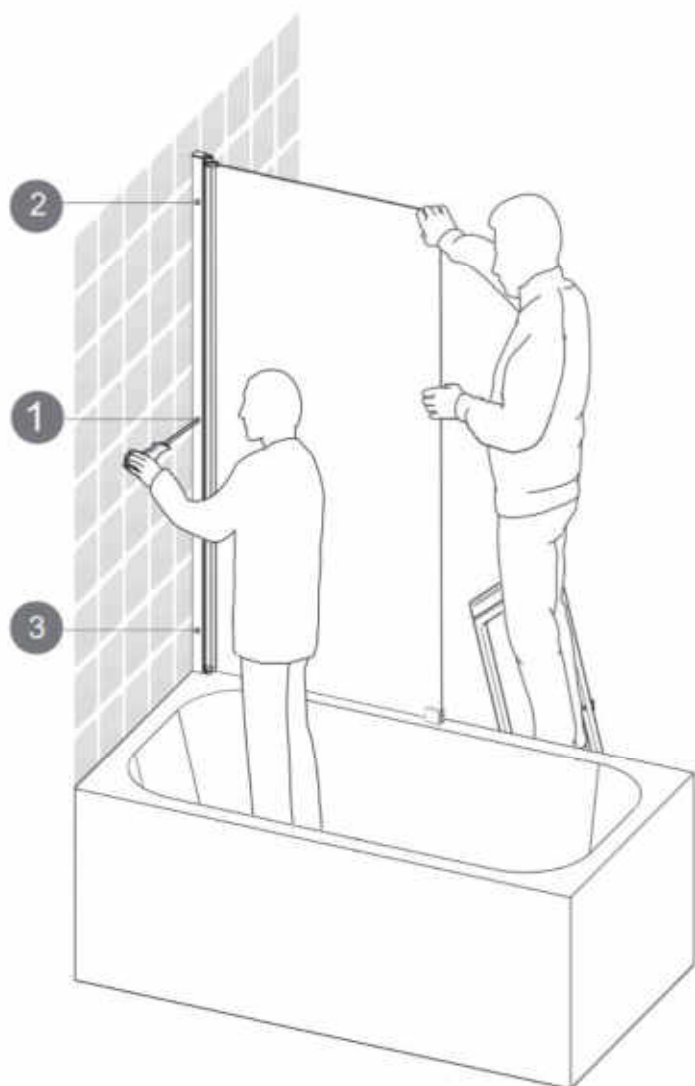
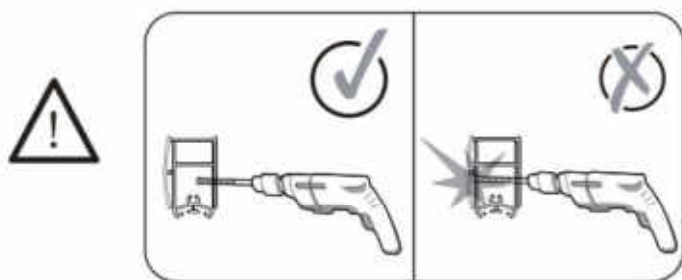

6.

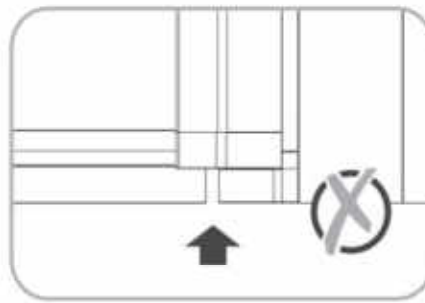
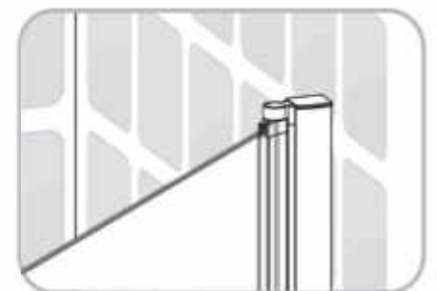
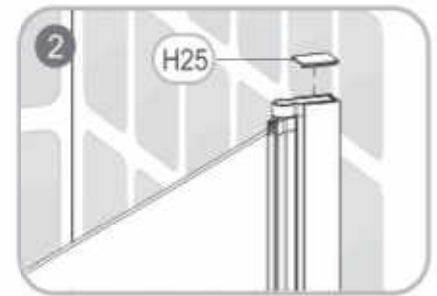
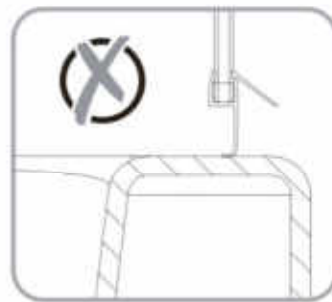
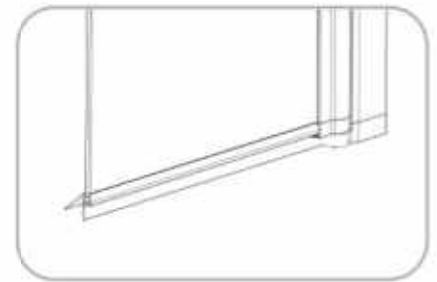
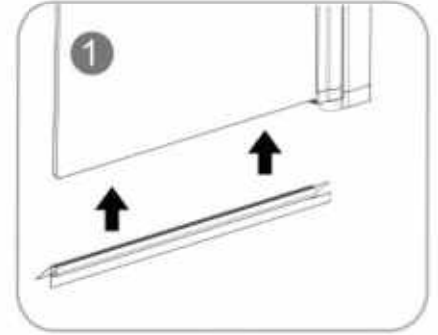
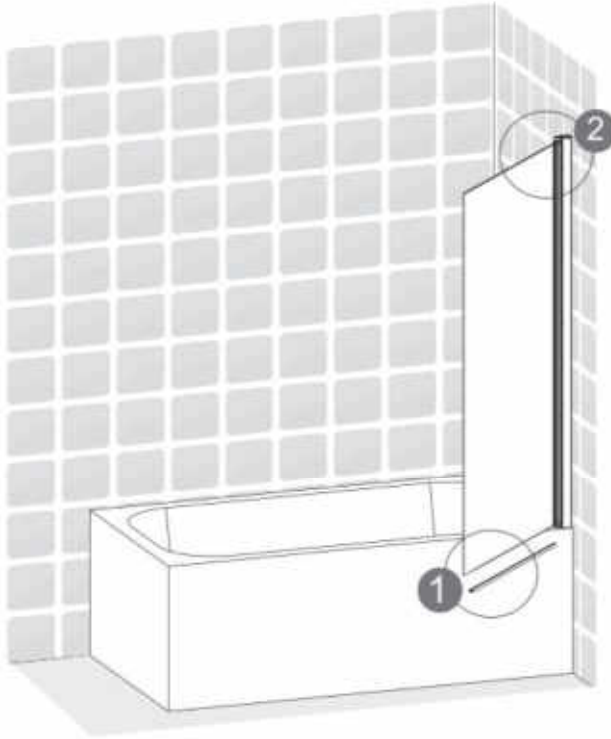
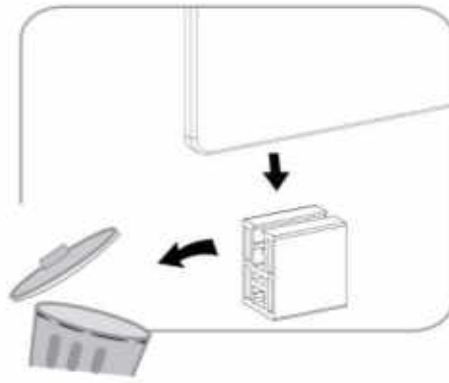

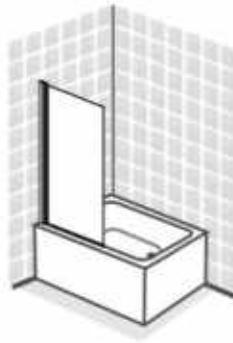

7.

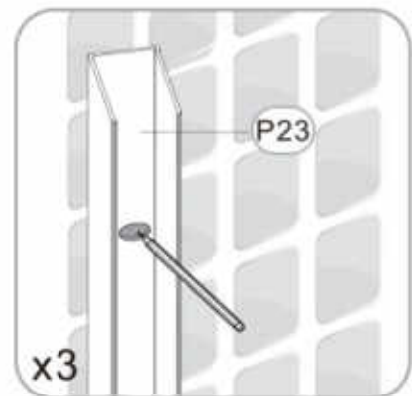
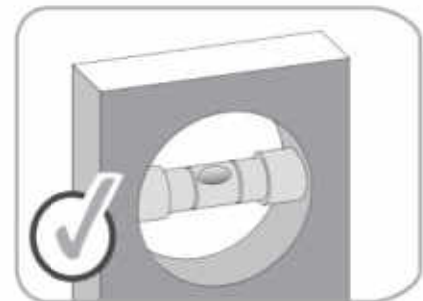
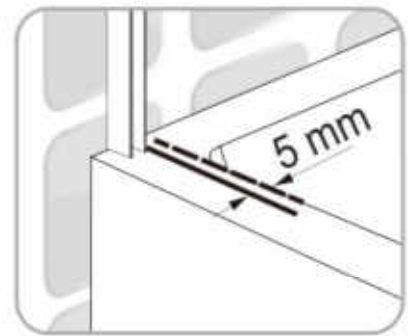
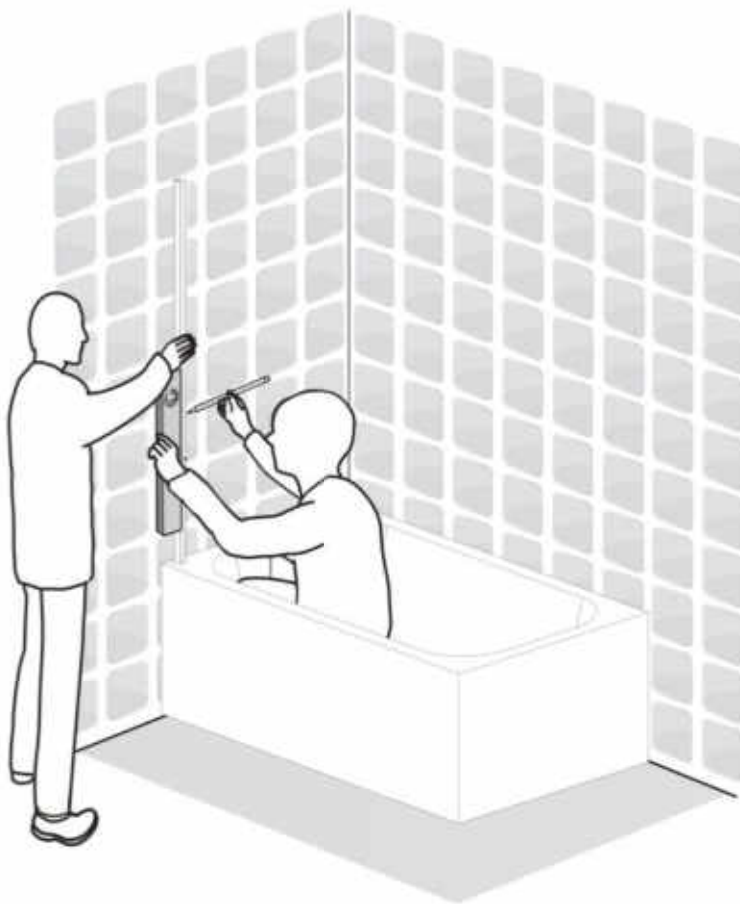

8.

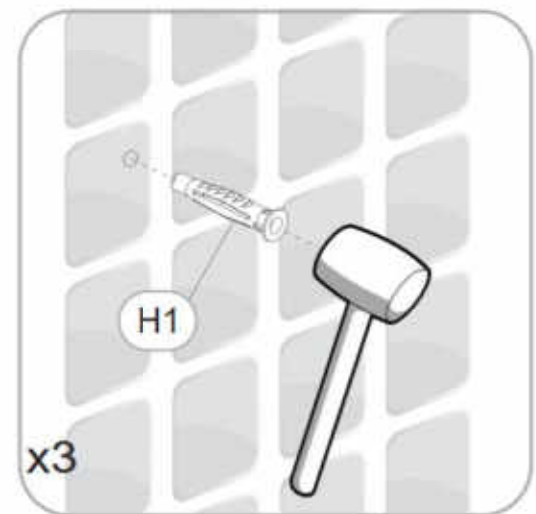
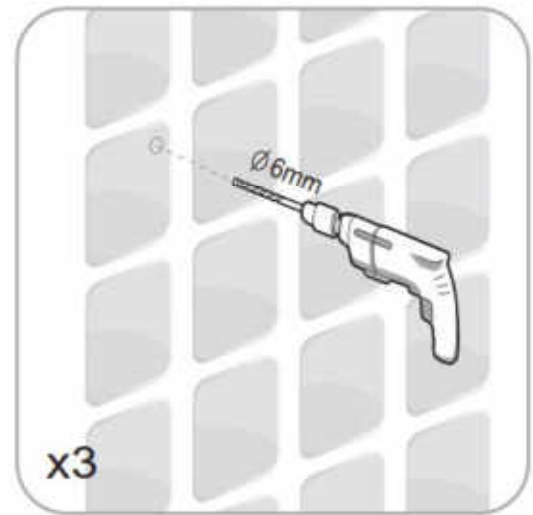
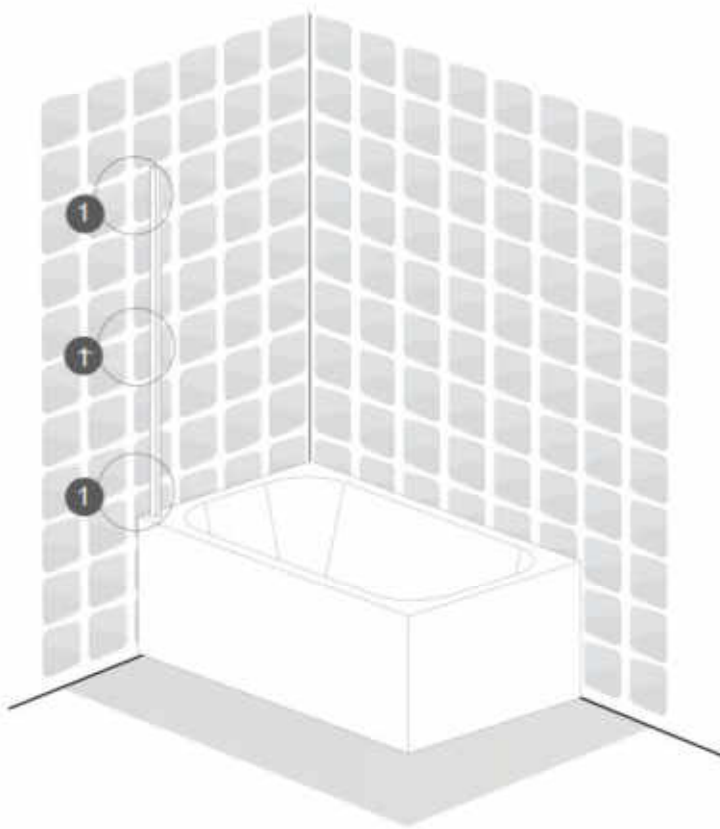
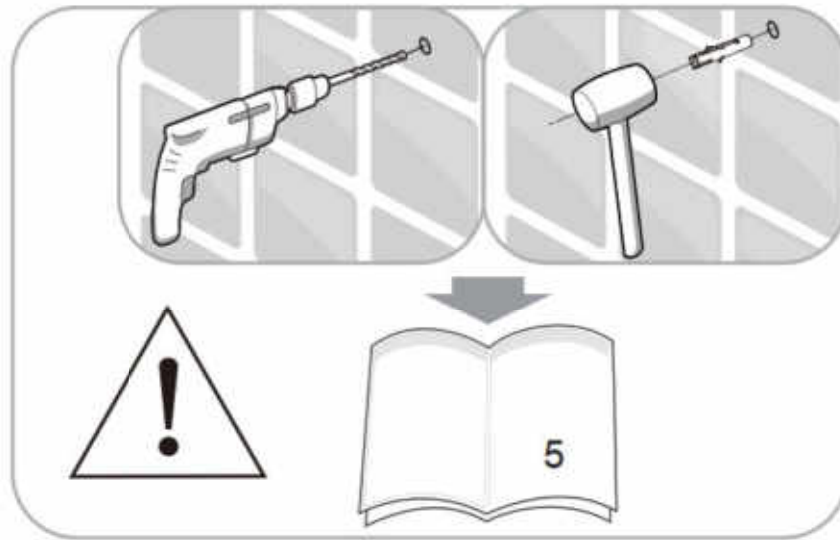

9.

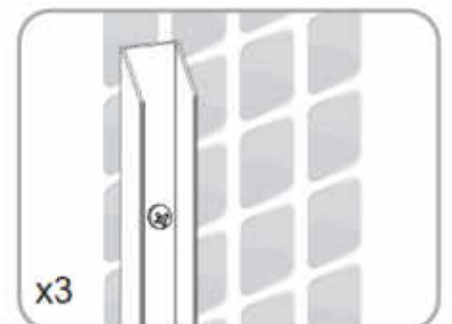
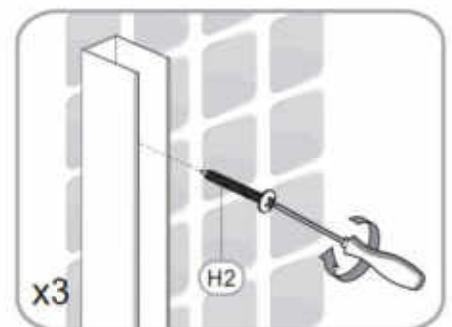
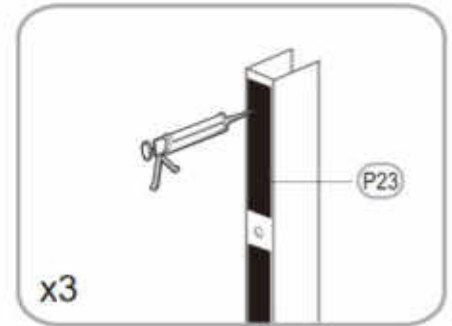
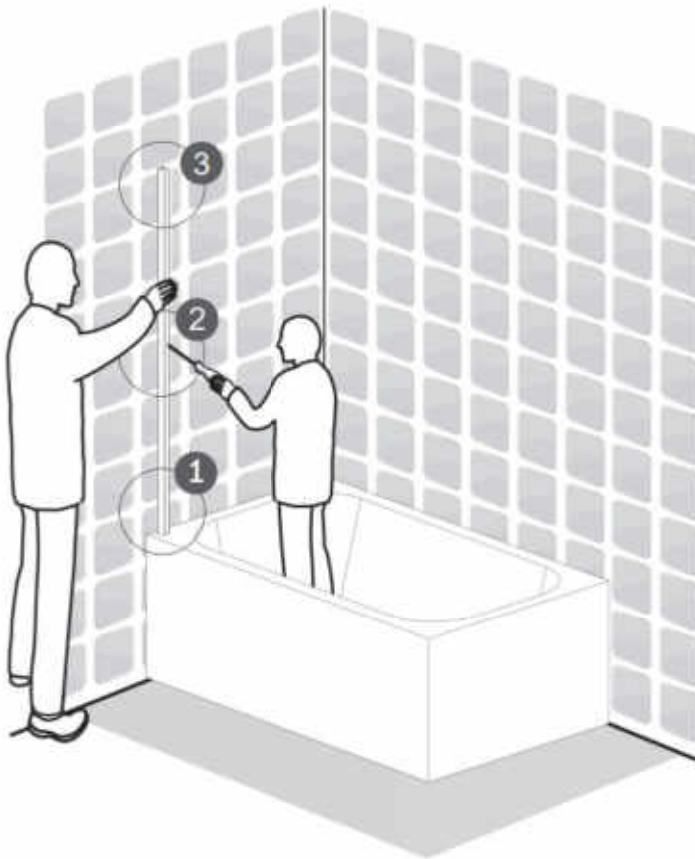

10.

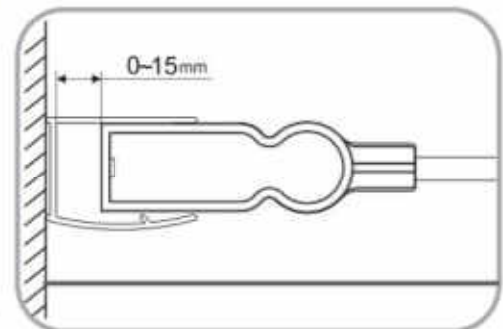
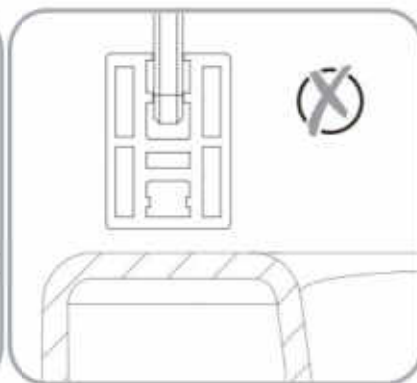
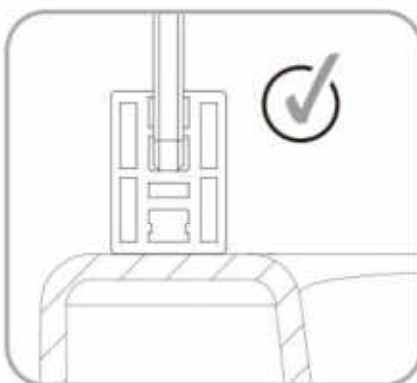
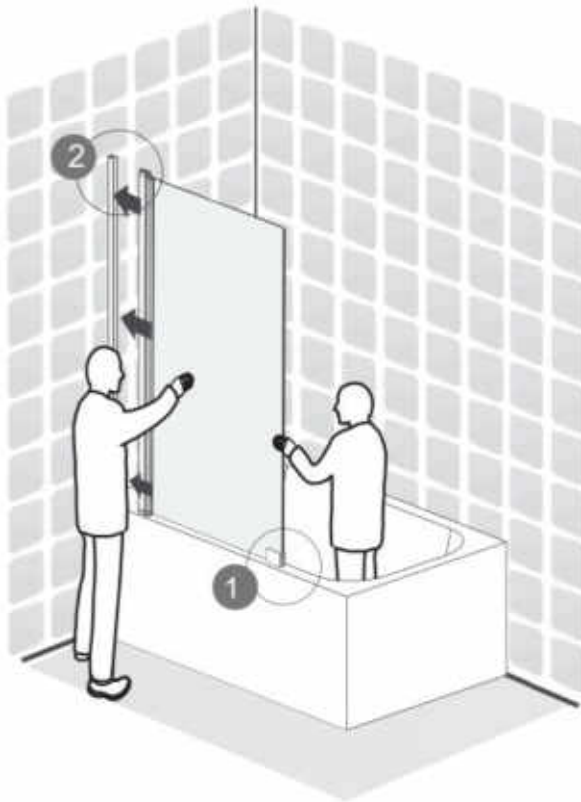
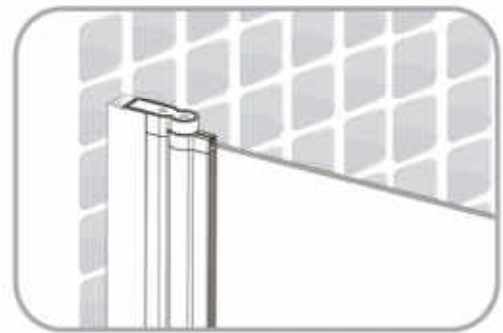
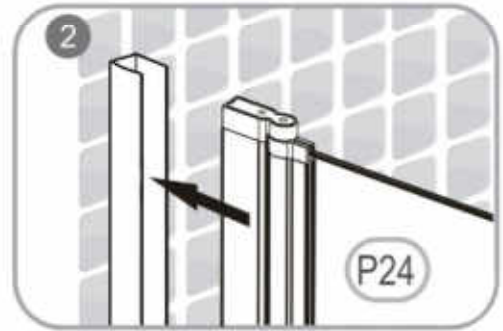
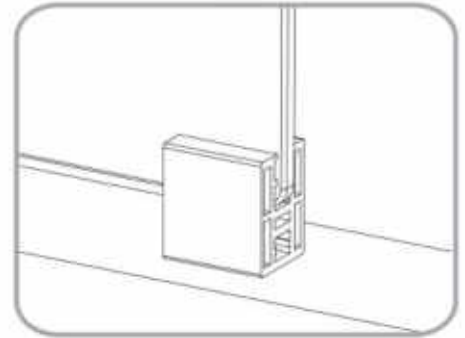
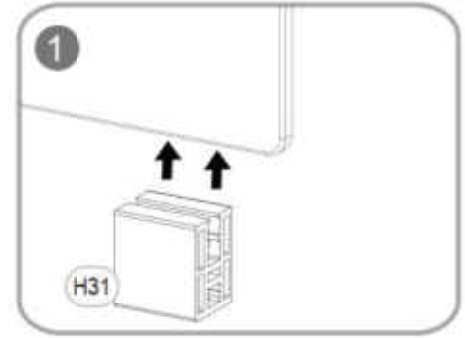
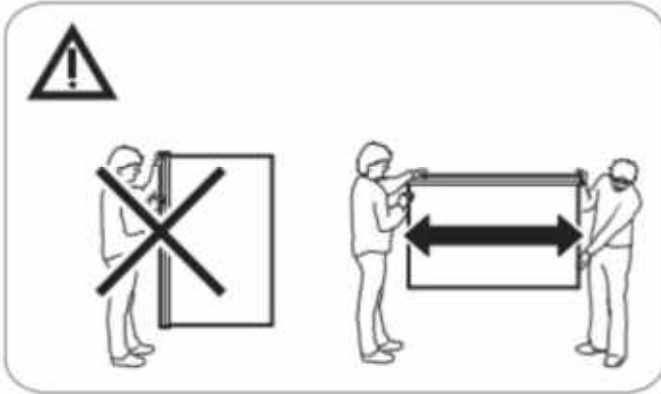

11.

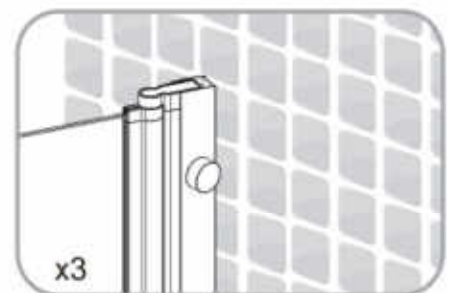
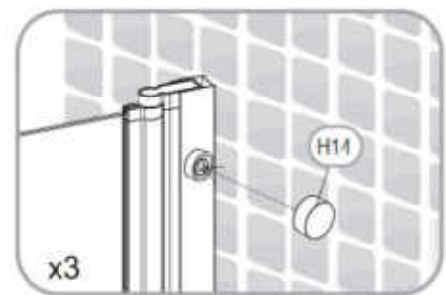
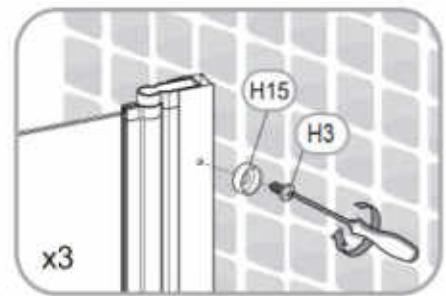
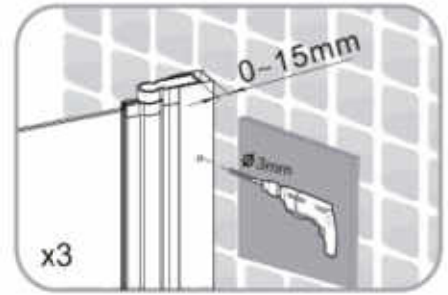
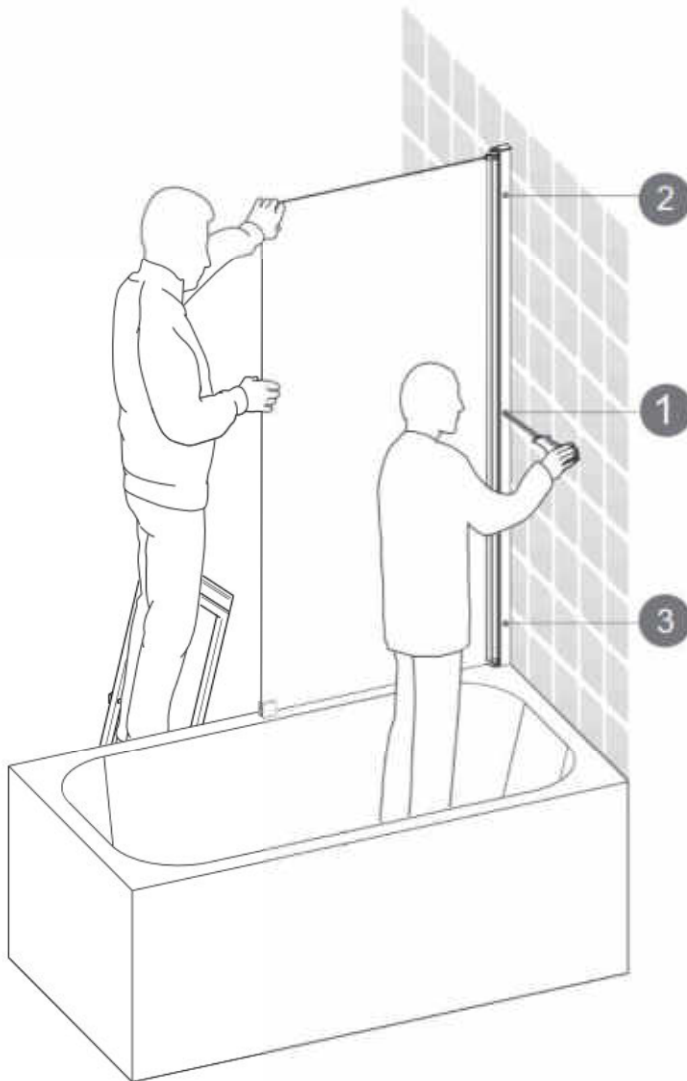
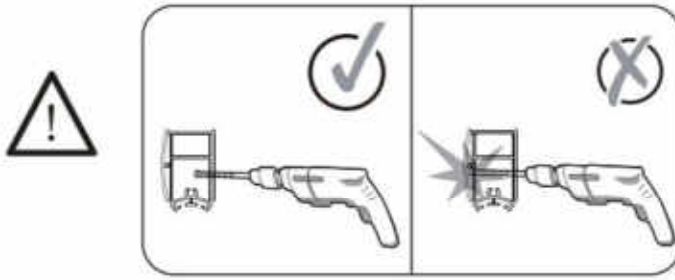

12.

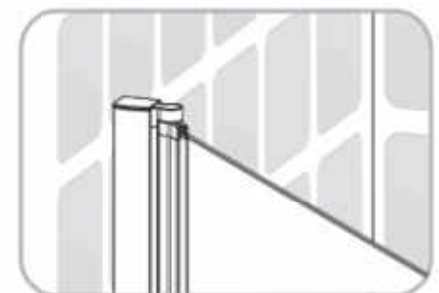
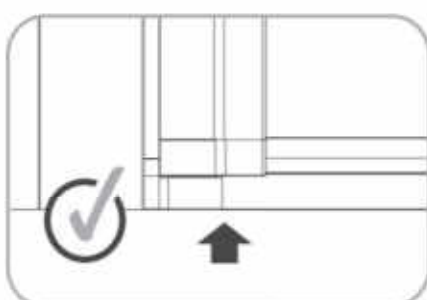
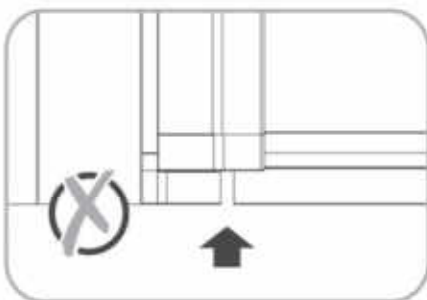
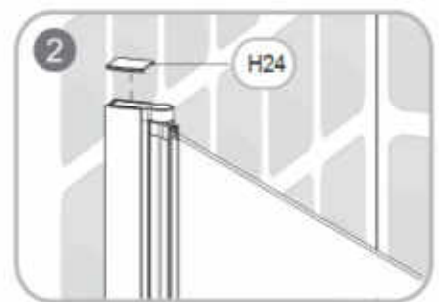
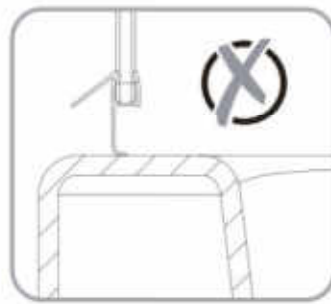
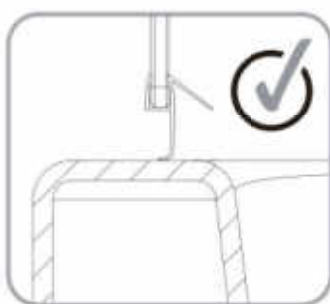
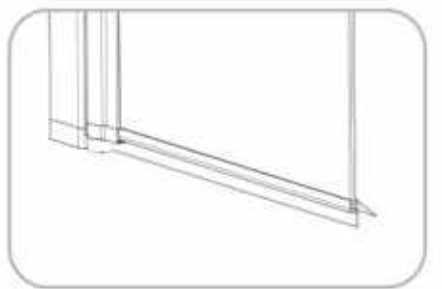
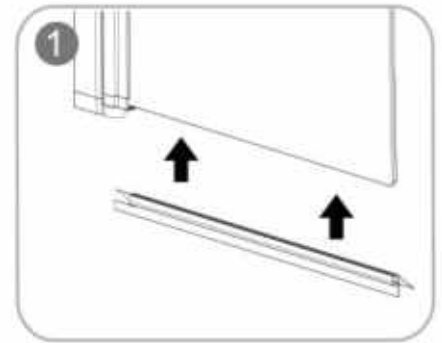
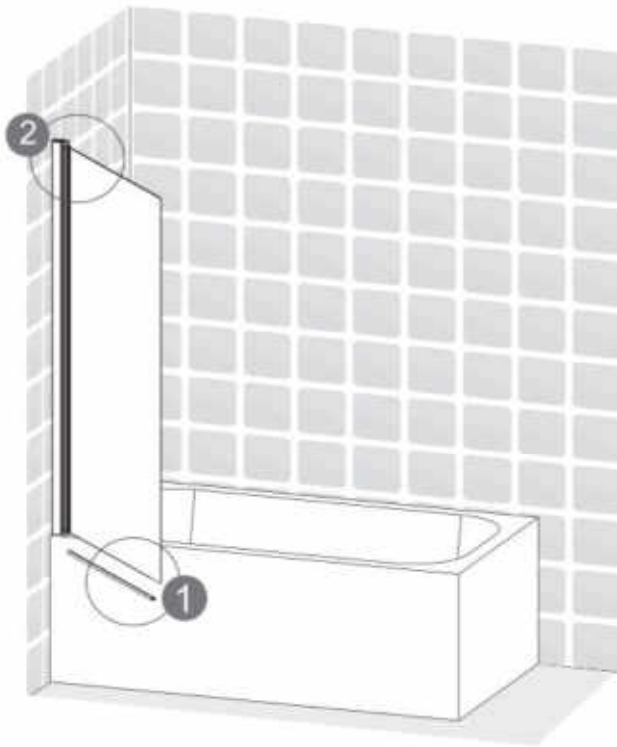
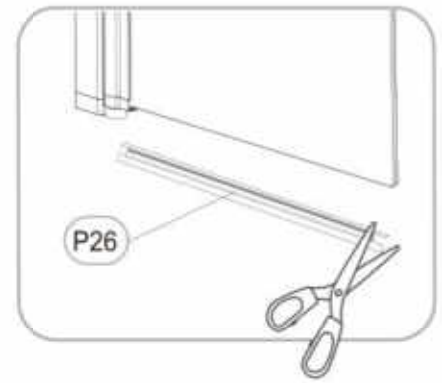
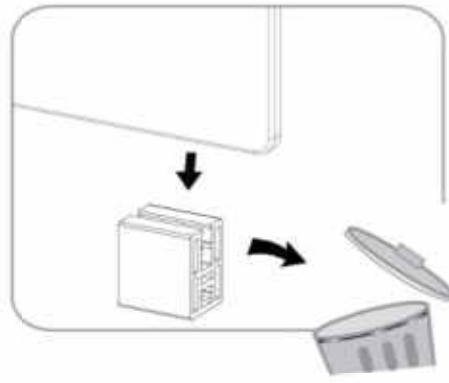

13.

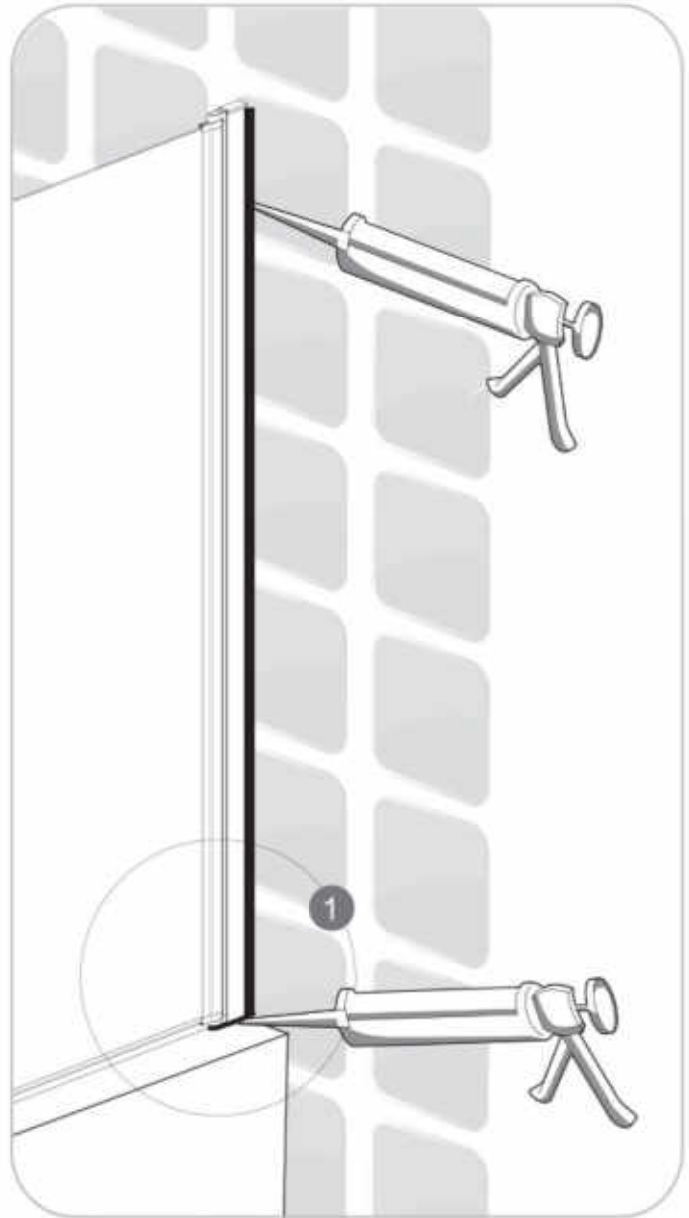
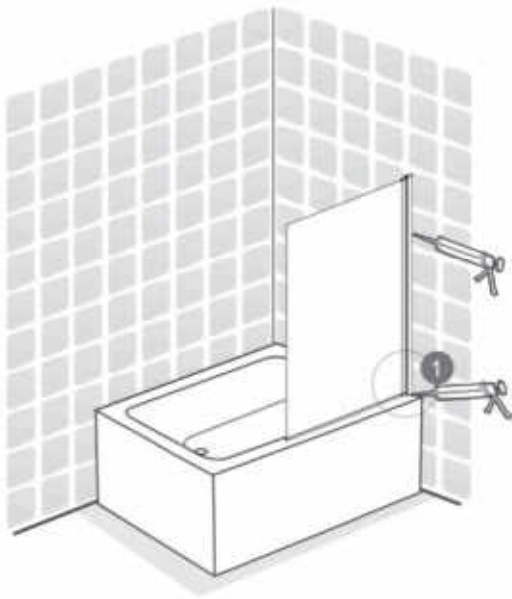

FR:SILICONE
ES:SILICIO
PT:SILÍCONE
IT:SILICONE
EL:ΣΙΛΙΚΟΝΙΟ
PL:SILIKON
UA:СИЛІКОНОВИЙ
RO:SILICONĂ
BR:SILÍCONE
EN:SILICONE

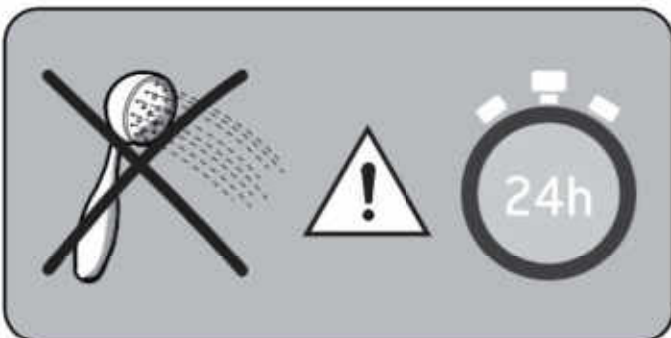

24h



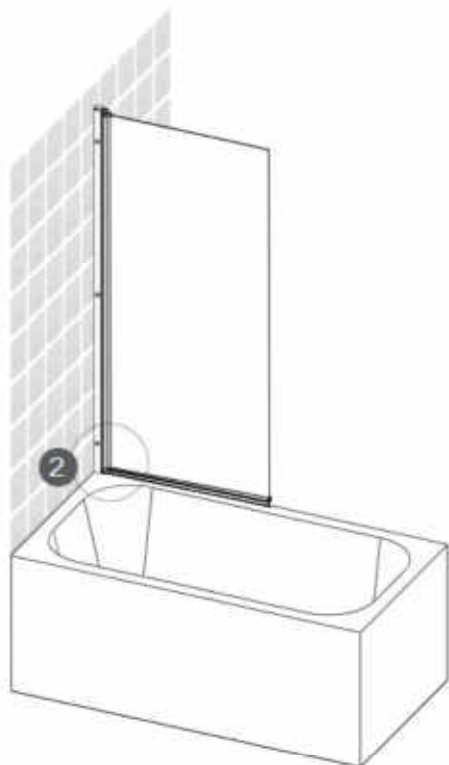

FR:SILICONE
ES:SILICIO
PT:SILÍCONE
IT:SILICONE
EL:ΣΙΛΙΚΟΝΙΟ
PL:SILIKON
UA:СИЛІКОНОВИЙ
RO:SILICONĂ
BR:SILÍCONE
EN:SILICONE

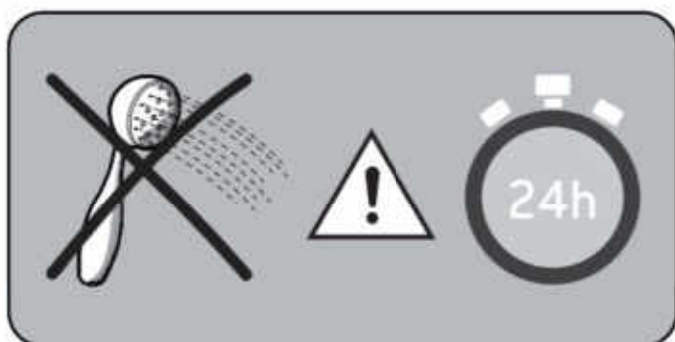
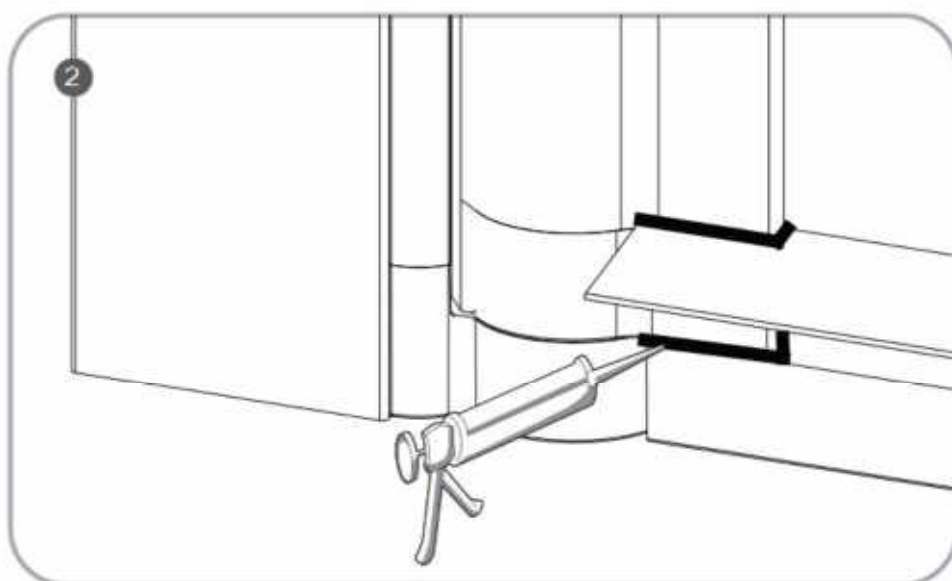

04

FR Entretien
IT Manutenzione
UA Технічне обслуговування
EN Maintenance

ES Mantenimiento
EL Συντήρηση
RO Întreținere

PT Manutenção
PL Konserwacja
BR Manutenção

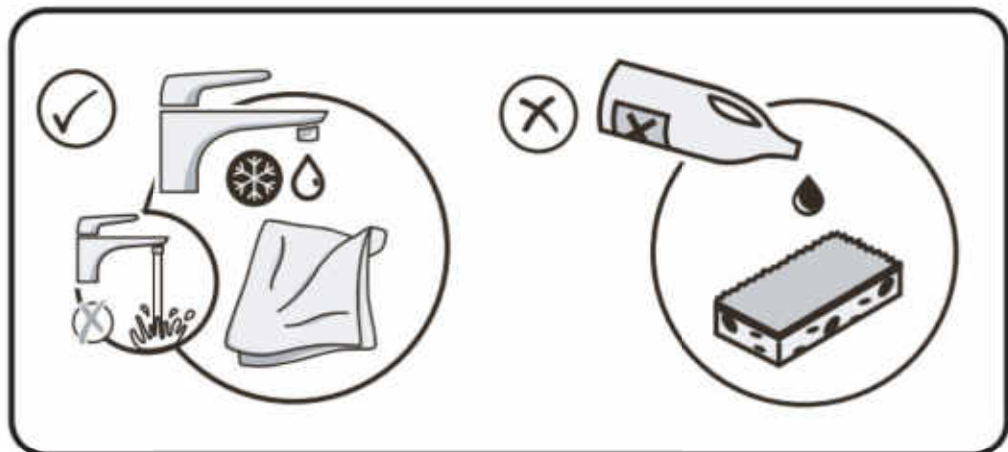

05

FR Documents
IT Documenti
UA Документи
EN Documents

ES Documentos
EL Έγγραφα
RO Documente

PT Documentos
PL Dokumenty
BR Documentos

EAN CODE	**MODEL NO.	SIZE (MM)	*DOP NUMBER
3276007112290	ESBS80SC	800×1400 silver	098114/0028/2020
3276007112306	ESBS80SF	800×1400 silver	098114/0028/2020

FR

CE

ADEO Services -135 Rue Sadi Carnot -
CS 00001 59790 RONCHIN - France
21
EN14428:2004+A1:2008

Code d'identification unique
du produit type: **

usage prévu: hygiène personnelle

Nettoyable: Conforme

Résistance à l'impact/
Capacité de Fragmentation: Conforme

durabilité: Conforme

DOP N° *

ES

CE

ADEO Services -135 Rue Sadi Carnot -
CS 00001 59790 RONCHIN - France
21
EN14428:2004+A1:2008

Código de identificación
única del producto tipo: **

Uso previsto: higiene personal

Limpiable: Conforme

Resistencia al impacto/
Capacidad de fragmentación: Conforme

Durabilidad: Conforme

DOP N° *

PT

CE

ADEO Services -135 Rue Sadi Carnot -
CS 00001 59790 RONCHIN - France
21
EN14428:2004+A1:2008

Código de identificação
único do produto-tipo: **

Utilização prevista: higiene pessoal

Limpeza: Conforme

Resistência ao impacto/
Capacidade de fragmentação: Conforme

Durabilidade: Conforme

DOP N° *

IT

CE

ADEO Services -135 Rue Sadi Carnot -
CS 00001 59790 RONCHIN - France
21
EN14428:2004+A1:2008

Codice di identificazione
unico del prodotto-tipo: **

Uso previsto: igiene personale

Pulibile: Conforme

Resistenza agli urti/
Capacità di Frammentazione: Conforme

Durata: Conforme

DOP N° *

EL

CE

ADEO Services -135 Rue Sadi Carnot -
CS 00001 59790 RONCHIN - France
21
EN14428:2004+A1:2008

Μοναδικός κωδικός ταυτοποίησης
του τύπου του προϊόντος: **

προβλεπόμενη χρήση: προσωπική υγιεινή

Δυνατότητα καθαρισμού: Σύμφωνα με

Αντοχή σε κρούση/
Ικανότητα κατάτμησης: Σύμφωνα με

Διάρκεια: Σύμφωνα με

DOP N° *

PL

CE

ADEO Services -135 Rue Sadi Carnot -
CS 00001 59790 RONCHIN - France
21
EN14428:2004+A1:2008

Niepowtarzalny kod
identyfikacyjny typu wyrobu: **

przeznaczenie: higiena osobista

Możliwość czyszczenia: Zgodny

Odporność na uderzenia/
Rozkruszalność: Zgodny

Trwałość: Zgodny

DOP N° *

RO

CE

ADEO Services -135 Rue Sadi Carnot -
CS 00001 59790 RONCHIN - France
21
EN14428:2004+A1:2008

Cod unic de identificare
a tipului de produs: **

destinație: igienă personală

Posibilitatea de curățare: Conform

Rezistență la impact/
Capacitate de fragmentare: Conform

Durabilitate: Conform

DOP N° *

EN

CE

ADEO Services -135 Rue Sadi Carnot -
CS 00001 59790 RONCHIN - France
21
EN14428:2004+A1:2008

Unique identification code
of the product-type: **

intended use: personal hygiene

cleanability: Pass

Impact resistance/ shatter properties: Pass

Durability: Pass

DOP N° *

* / **

FR Reportez-vous à l'annexe.

ES Consulte el apéndice.

PT Consulte o anexo.

IT Consultare l'appendice.

EL Ανατρέξτε στο Παράρτημα.

PL Patrz załącznik.

RO Consultați anexa.

EN Refer to appendix.

UA Див. додаток.

BR Consulte o apéndice.



Made in China

Garantie 5 ans / 5 años de garantía / Garantia de 5 anos / Garanzia 5 Anni / Εγγύηση 5 ετών /
Gwarancja 5-letnia / Гарантія 5 років / Garanție 5ani / Garantia de 5anos / 5-year guarantee

ADEO Services - 135 rue Sadi Carnot - CS 00001. 59790 RONCHIN – FRANCE

Imported by Adeo South Africa (PTY) LTD T/A
Leroy Merlin,
Hosted in Leroy Merlin Fourways Store 35 Roos
Street, Witkoppen Ext 97, Sandton, 2191
Johannesburg, Gauteng, South Africa
Tel: +27 10 493 8000 Email: contact@leroymerlin.co.za

Importado e distribuído por LEROY MERLIN
COMPANHIA BRASILEIRA DE BRICOLAGEM
CNPJ: 01.438.784/0001-05
Rua Pascoal Pais, nº. 525, 6º andar cj 61 a 64,
Vila Cordeiro, São Paulo -SP. CEP: 04581-060
CALM (Central de Atendimento Leroy Merlin)
Capitais 4020-5376 Demais Regiões
0800-0205376

Виробник: ТОВ "Адео Сервісез С.А.",
вул. Саді Карно, CS 00001, 59790 Роншен, Франція.
Імпортер, суб'єкт господарювання,
що відповідає за виконання гарантійних зобов'язань :
ТОВ "Леруа Мерлен Україна", 04201 Україна, м.Київ, вул.
Полярна 17А, +380 44 498 46 00.