

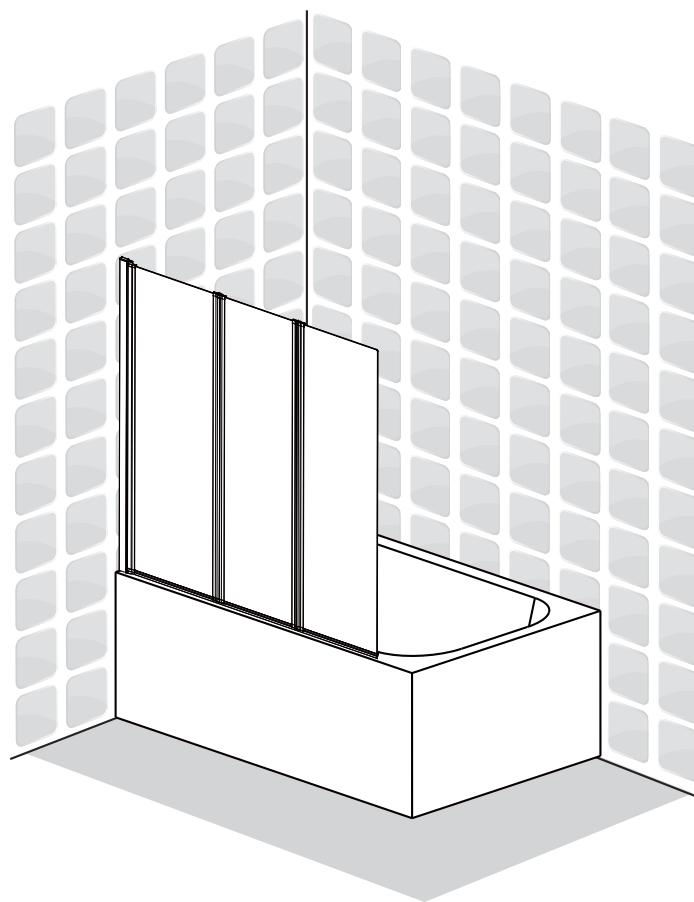

5
YEARS
Guarantee*

ESSENTIAL



EAN CODE : 3276007112498
3276007112504



FR Notice de Montage -
Utilisation - Entretien

ES Instrucciones de Montaje,
Utilización y Mantenimiento

PT Instruções de Montagem,
Utilização e Manutenção

IT Istruzioni per il Montaggio,
l'Uso e la Manutenzione

EL Εγχειρίδιο συναρμολόγησης,
χρήσης και συντήρησης

PL Instrukcja Montażu,
Użytkowania i Konserwacji

RU Руководство По Сборке
и Эксплуатации

KZ Жинау, пайдалану және
техникалық қызмет
көрсету нұсқаулығы

UA Керівництво По Збірці
і Експлуатації

RO Manual asamblare,
utilizare și întreținere

EN Assembly - Use -
Maintenance Manual



- FR** Nous vous remercions d'avoir acheté ce produit. Nous vous conseillons de lire attentivement la notice d'installation, d'utilisation et d'entretien. Nous avons conçu ce produit pour vous apporter entière satisfaction.
Si vous avez besoin d'aide l'équipe de votre magasin est à votre disposition pour vous accompagner.
- ES** Le agradecemos haber comprado este producto. Le recomendamos leer atentamente el manual de instalación, uso y mantenimiento. Este producto ha sido diseñado para proporcionarle plena satisfacción.
Si necesita alguna ayuda, el personal de la tienda estará a su disposición para guiarle.
- PT** Agradecemos a sua preferência por este produto. Aconselhamo-lo a ler o manual de instalação, utilização e manutenção com atenção. Criámos este produto para sua completa satisfação.
Se precisar de ajuda, a equipa da sua loja está à sua disposição para o acompanhar.
- IT** Grazie per aver acquistato questo prodotto. Vi raccomandiamo di leggere attentamente il manuale di installazione, utilizzo e manutenzione. Questo prodotto è stato progettato per offrirvi la massima soddisfazione.
Per ricevere assistenza, il personale del punto vendita è a vostra disposizione.
- EL** Ευχαριστούμε για την αγορά σας αυτού του προϊόντος. Σας συμβουλεύουμε να διαβάσετε προσεκτικά τις οδηγίες εγκατάστασης, χρήσης και συντήρησης. Σχεδιάσαμε αυτό το προϊόν για να σας προσφέρει πλήρη ικανοποίηση.
Αν χρειάζεστε βοήθεια, η ομάδα του καταστήματος από το οποίο αγοράσατε το προϊόν είναι στη διάθεσή σας
- PL** Dziękujemy za zakup produktu firmy. Zalecamy, aby uważnie przeczytać instrukcję instalacji, użytkowania i konserwacji. Ten produkt marki zaprojektowaliśmy, aby spełnić wszystkie Państwa oczekiwania.
W razie potrzeby pracownicy sklepu służą Państwu pomocą i są do Państwa dyspozycji.
- RU** Благодарим Вас за приобретение изделия. Рекомендуем внимательно прочитать инструкции по установке, эксплуатации и техническому обслуживанию. Изделие разработано, чтобы доставить Вам удовольствие.
Если Вам потребуется помощь, консультанты Вашего магазина находятся в Вашем распоряжении.
- KZ** Өнімін сатып алғаныңыз үшін алғыс білдіреміз. Орнату, қолдану және қызмет көрсету жөніндегі нұсқаулықтарды мұқият оқып шығуға кеңес береміз. Біз бұл өнімін сізді толықтай қанағаттандыру үшін жасап шығардық.
Егер сізге көмек қажет болса сіздің бөлшектеп сататын дүкеніңіздегі топ сізге жәрдем береді.
- UA** Дякуємо вам за покупку цього виробу. Ми радимо вам уважно прочитати інструкції з установлення, експлуатації та технічного обслуговування. Ми розробили цей виріб для того, щоб він приносив вам задоволення.
Якщо вам потрібна допомога, співробітники вашого магазину готові допомогти вам
- RO** Vă mulțumim pentru achiziționarea acestui produs. Vă sfătuim să citiți cu atenție instrucțiunile de instalare, de utilizare și de întreținere. Am conceput acest produs pentru a vă furniza satisfacție totală.
Dacă aveți nevoie de ajutor, echipa magazinului de cumpărare este la dispoziția dumneavoastră pentru a vă asista.
- EN** Thank you for purchasing this product. We recommend that you read the installation, user and maintenance instructions carefully. We have designed this product to ensure your complete satisfaction.
If you require assistance, the team at your retailer is on hand to help you.

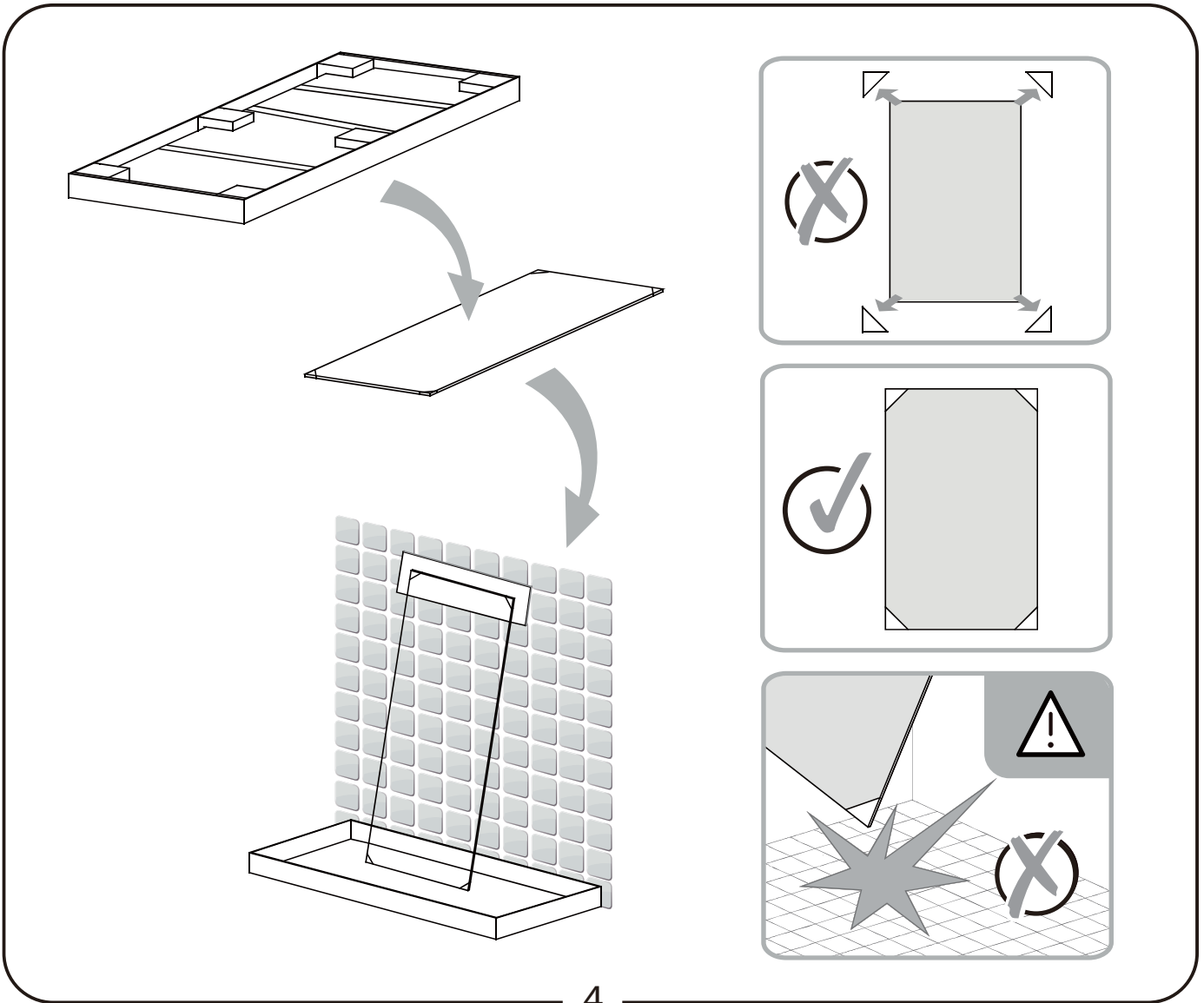
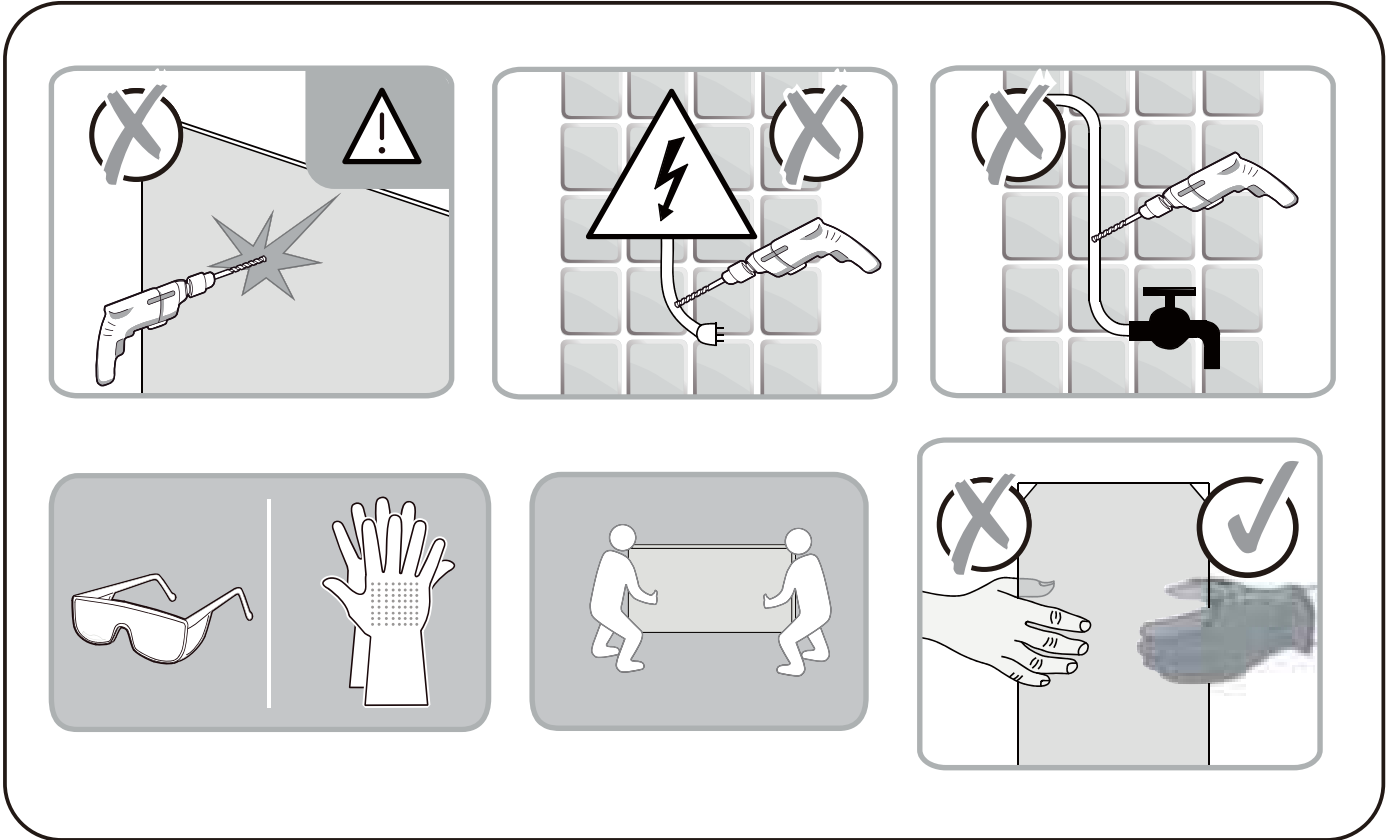

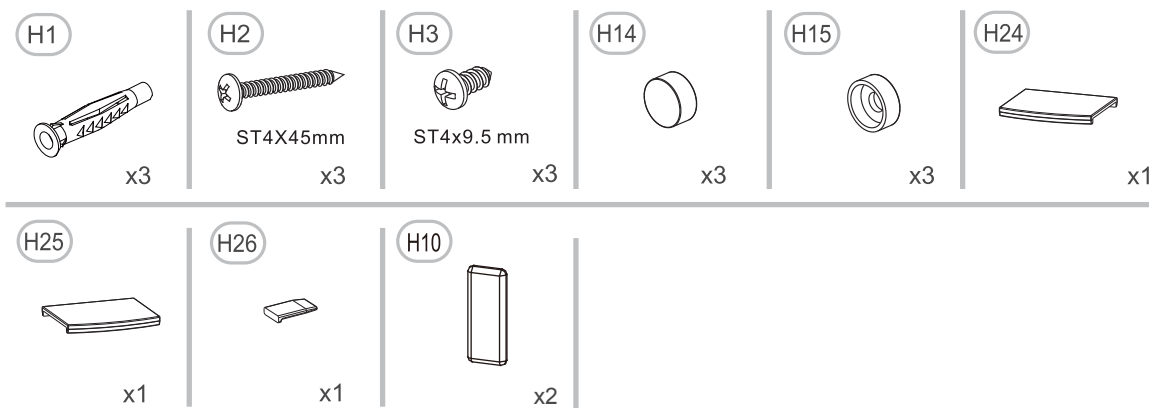
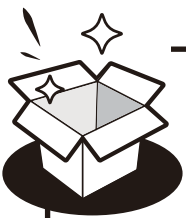
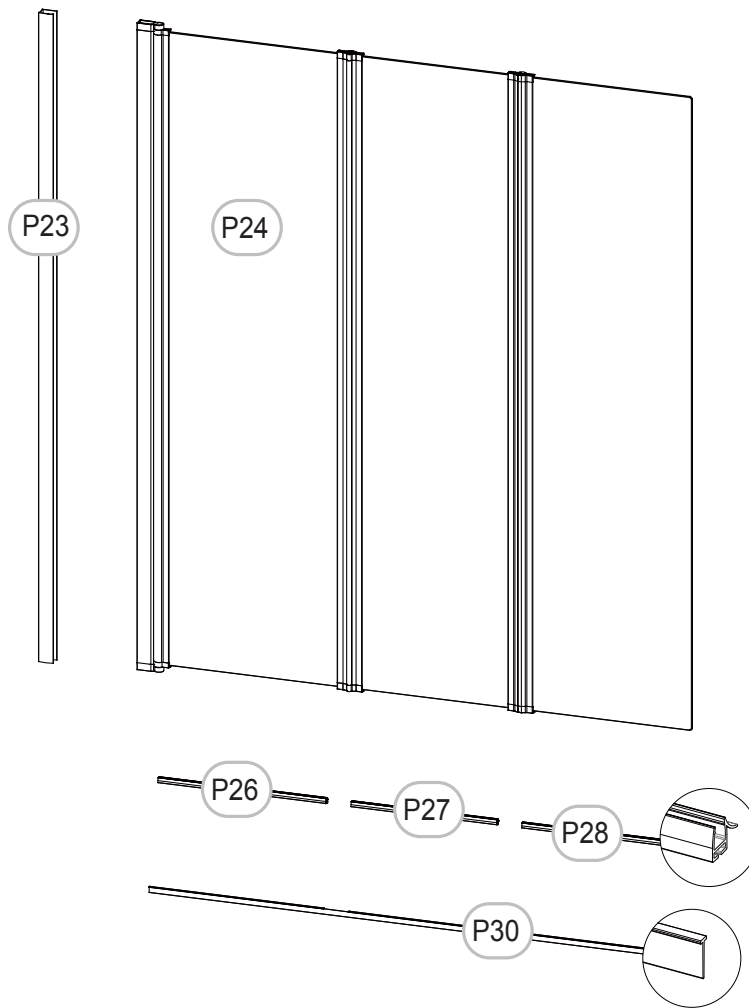

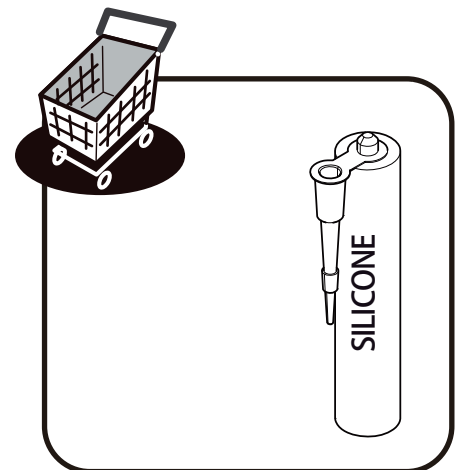
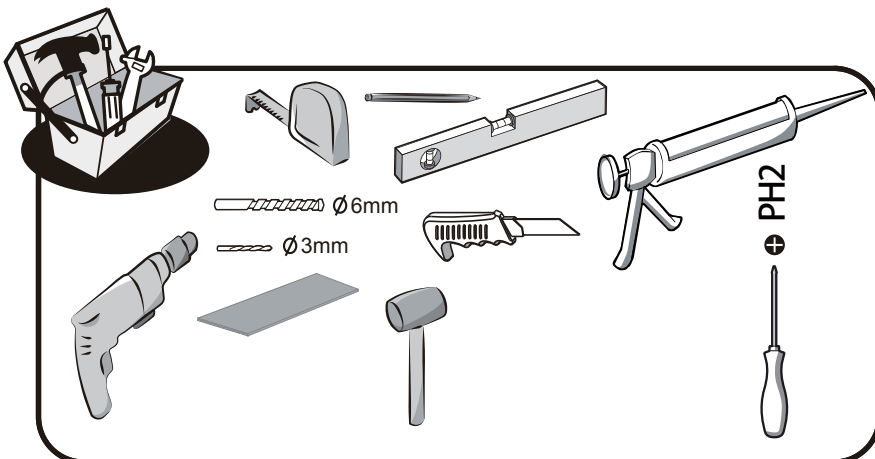
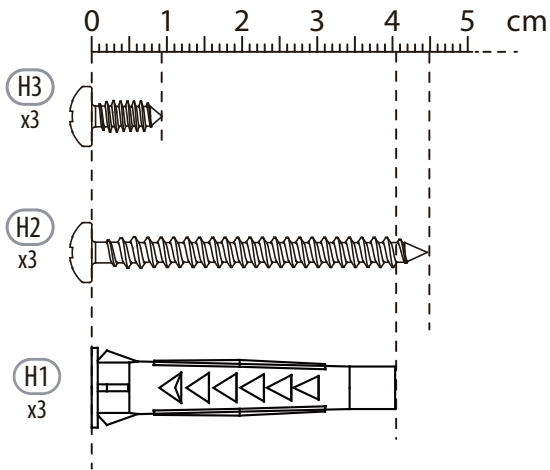
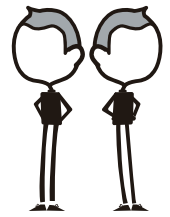
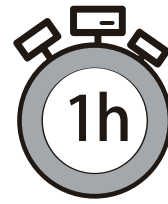
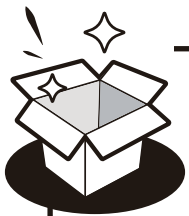



FR: Préparation / **ES:** Preparación / **PT:** Preparação / **IT:** Preparazione / **EL:** Προετοιμασία /
PL: Przygotowanie / **RU:** Подготовка / **KZ:** Дайындау / **UA:** Підготування / **RO:** Pregătire /
EN: Preparation



3 → 8



FR: Montage / **ES:** Montaje / **PT:** Montagem / **IT:** Montaggio / **EL:** Συναρμολόγηση /
PL: Montaż / **RU:** Сборка / **KZ:** Монтаждау / **UA:** Збірка / **RO:** Montaj / **EN:** Assembly



9 → 25



FR: Entretien / **ES:** Mantenimiento / **PT:** Manutenção / **IT:** Manutenzione / **EL:** Συντήρηση /
PL: Konserwacja / **RU:** Уход / **KZ:** Және техникалық қызмет көрсету / **UA:** Догляд / **RO:** Întreținere /
EN: Maintenance



26



FR: Mentions Légales & Consignes de Sécurité / **ES:** Instrucciones Legales y de Seguridad /
PT: Avisos Legais e instruções de Segurança / **IT:** Istruzioni Legali e di Sicurezza /
EL: Νομικό σημείωμα και οδηγίες ασφαλείας / **PL:** Uwagi Prawne i Instrukcja Bezpieczeństwa /
RU: Руководство по технике безопасности и правовым нормам /
KZ: Қауіпсіздік және құқықтық басшылық / **UA:** Керівництво з Техніки /
RO: Manual privind siguranța / **EN:** Legal & Safety Instructions



27



I

- FR** Vérifiez que les chevilles murales fournies sont appropriées à votre mur (celles fournies dans l'emballage sont conçues pour le béton). Sinon, utilisez des vis et des chevilles murales adaptées au type de matériau de votre mur. Pour obtenir des conseils concernant les vis et les chevilles appropriées à votre mur, demandez à un vendeur spécialisé.
- ES** Compruebe que todos los tacos suministrados puedan ser utilizados con su pared (los incluidos en la caja son para hormigón). En caso contrario, utilice tornillos y tacos de pared apropiados para el material de su pared. Para información acerca de las fijaciones y tornillos apropiados para su pared, consulte con un asistente de ventas especializado.
- PT** Certifique-se de que as buchas fornecidas são adequadas à sua parede (as fornecidas na embalagem são para betão). Caso contrário, use parafusos e buchas adequados ao tipo de material da sua parede. Para se aconselhar acerca dos parafusos e buchas adequados à sua parede, fale com um assistente de vendas especializado.
- IT** Verificare che i tasselli da parete forniti siano compatibili con la propria parete (quelli forniti con l'articolo sono per cemento). Altrimenti, utilizzare viti e tasselli adatti per la superficie della propria parete. Per ottenere consigli e suggerimenti sulle viti e i tasselli più adatti alla propria parete, consultare un rivenditore specializzato.
- EL** Βεβαιωθείτε ότι οι παρεχόμενες στερεώσεις τοίχου είναι κατάλληλες για τον τοίχο σας (οι παρεχόμενες στη συσκευή προορίζονται για μπετό). Αλλιώς χρησιμοποιήστε βίδες και στερεώσεις τοίχου κατάλληλες για τον τύπο υλικού του τοίχου σας. Για να λάβετε συμβουλές σχετικά με τις κατάλληλες βίδες και τα εξαρτήματα για τον τοίχο σας, ρωτήστε έναν ειδικό πωλητή.
- PL** Prosimy sprawdzić, czy dostarczone kołki do ścian nadają się do użycia w posiadanej ścianie (kołki dostarczone w zestawie są przeznaczone do betonu). Jeśli tak nie jest, należy użyć śrub i kołków odpowiednich do materiału, z którego wykonana jest ściana. Aby uzyskać poradę w sprawie śrub i elementów montażowych odpowiednich do danego typu ściany, należy zwrócić się z pytaniem do wyspecjalizowanego sprzedawcy.
- RU** Убедитесь, что прилагаемые дюбеля подходят для ваших стен (входящие в комплект дюбеля предназначены для бетона). В противном случае используйте шурупы и дюбеля, соответствующие материалу стены. Для получения рекомендаций по выбору шурупов и крепежных деталей, подходящих для вашей стены, обратитесь к специалисту-консультанту.
- KZ** Жеткізілетін қабырға анкерінің (қаланған тастарды ұстастыратын темір) сіздің қабырғаңызға үйлесімділігін тексеріңіз (жиынтыққа кіретіні бетонға арналған). Олай болмаған жағдайда, қабырғаңыздың материалының түріне сәйкес бұрмашеге мен қабырға анкерін пайдаланыңыз. Қабырғаңызға сәйкес бұрмашегелер мен бөлшектер туралы ақпарат алу үшін сату бөлімінің кеңесшісіне хабарласыңыз.
- UA** Перевірте, що анкери підходять для вашої стіни (ті, що постачаються в упаковці – для бетону). В іншому випадку використовуйте гвинти й стінові анкери, що відповідають матеріалу вашої стіни. Для отримання консультацій щодо гвинтів й фітингів для вашої стіни зверніться до відповідного продавця-консультанта.
- RO** Verificați ca toate ancorele de perete furnizate să fie adecvate pentru peretele dumneavoastră (cele furnizate în pachet sunt pentru beton). În caz contrar, folosiți șuruburi și ancore de perete adecvate pentru tipul de material din care este peretele dumneavoastră. Pentru a obține recomandări privind șuruburile și armăturile adecvate pentru peretele dumneavoastră, întrebați un vânzător specializat.
- EN** Check that wall anchors provided are suitable for your wall (those provided in the package are for concrete). Otherwise, use screws and wall anchors suited to the type of material of your wall. To obtain advice on the screws and fittings suited to your wall, ask a specialized sales assistant.



1

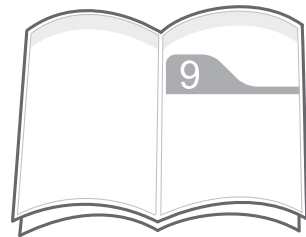
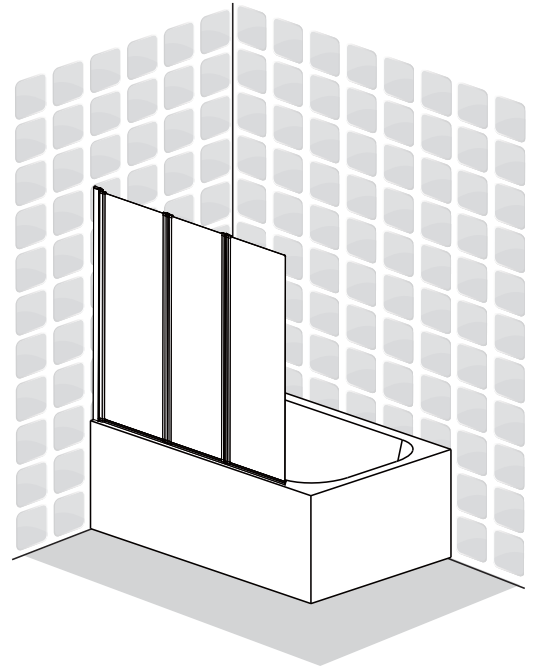
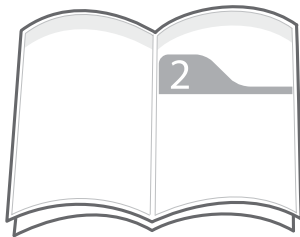
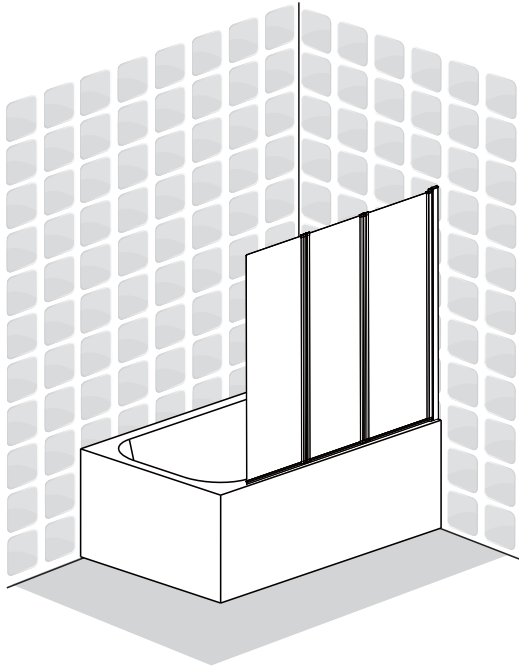



2

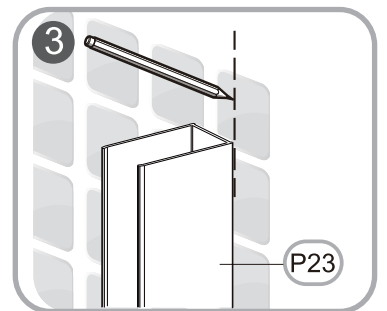
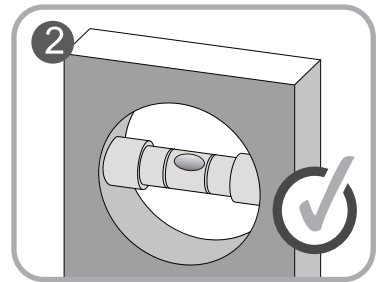
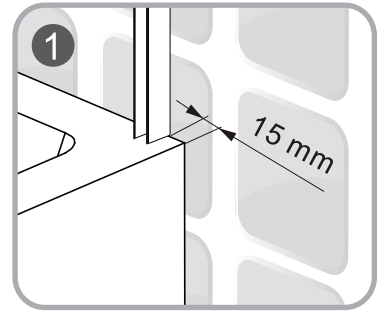
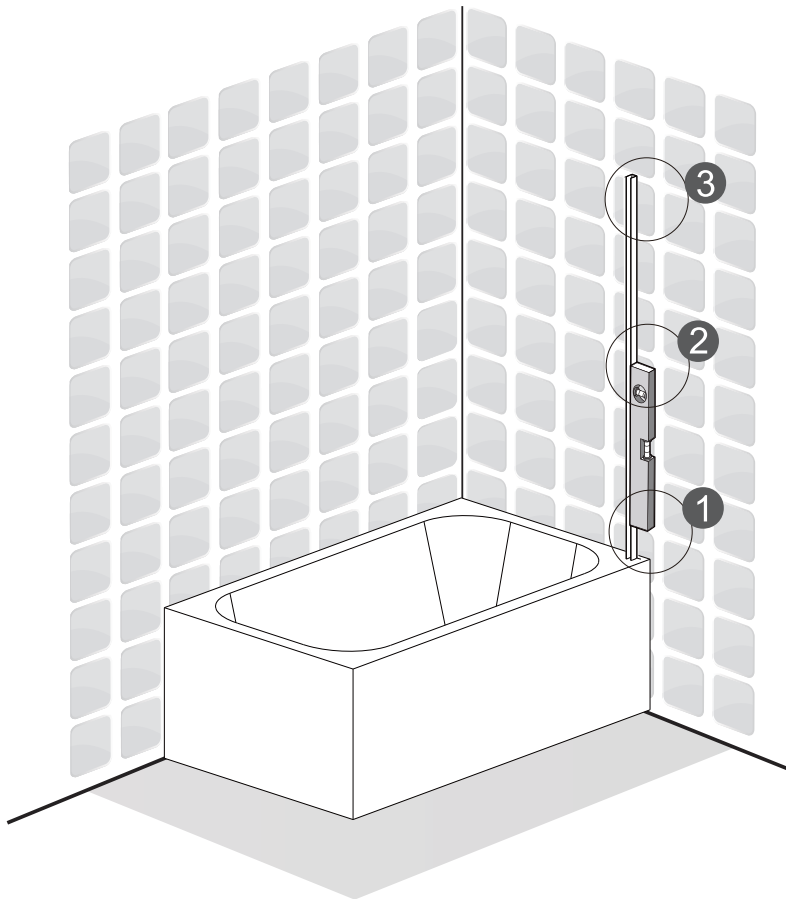
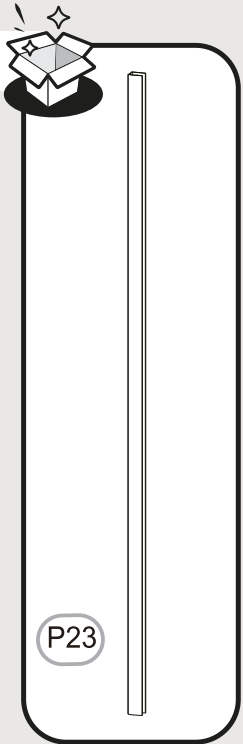

3

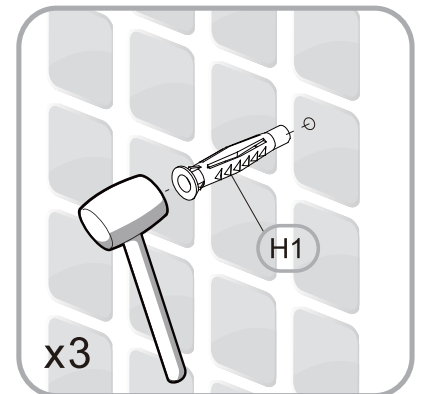
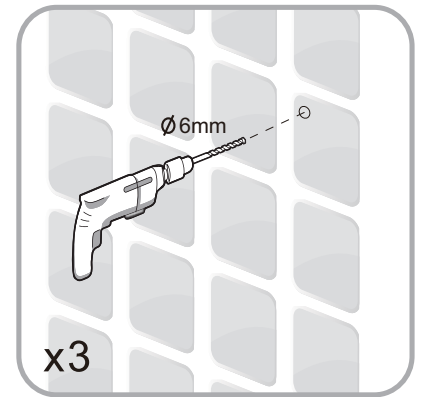
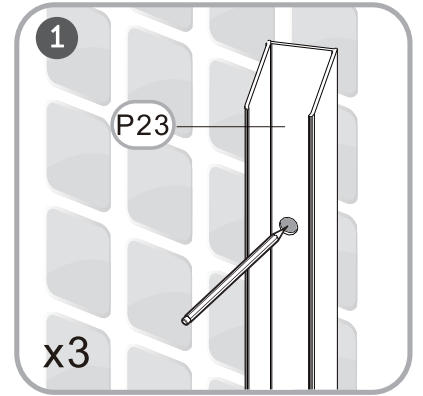
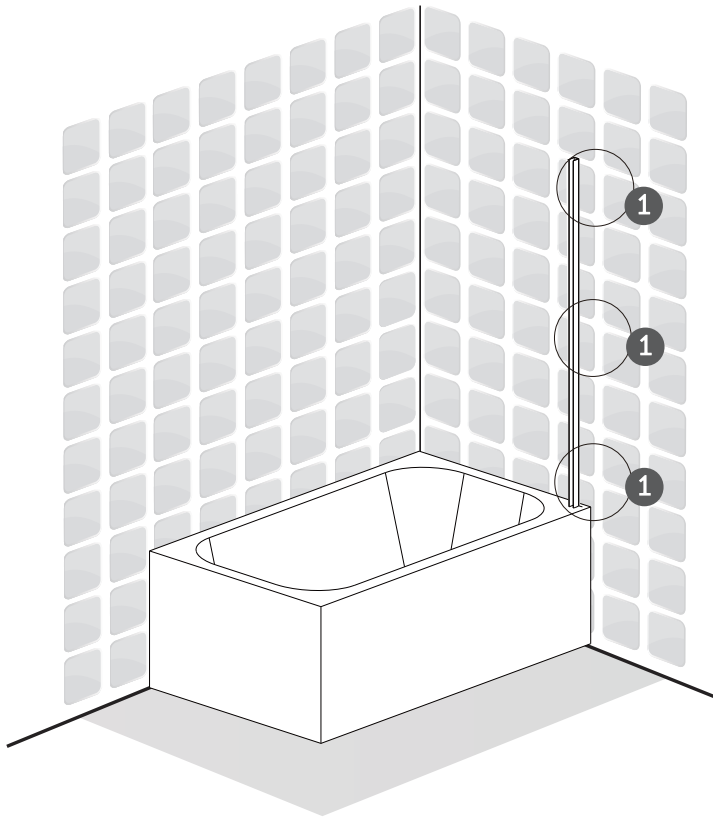
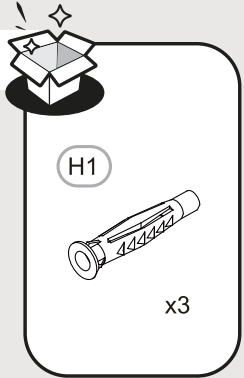
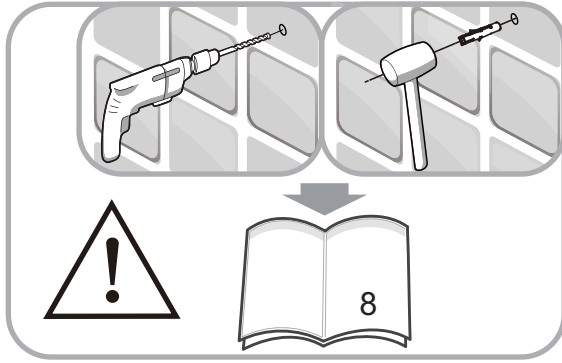

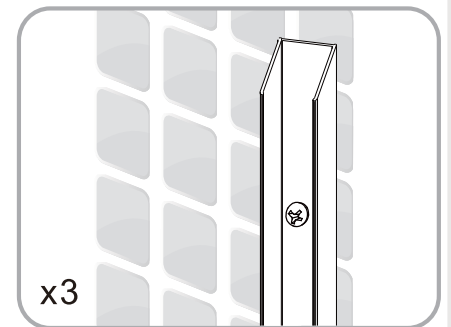
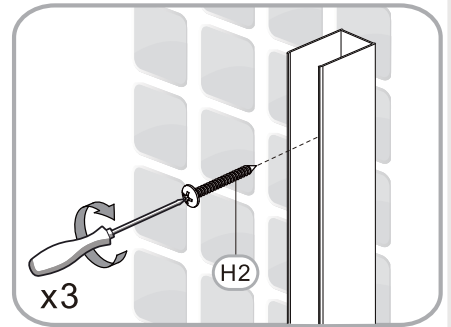
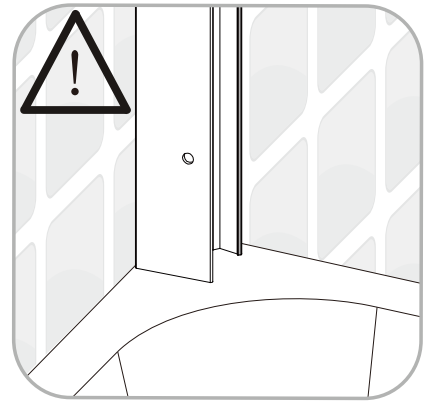
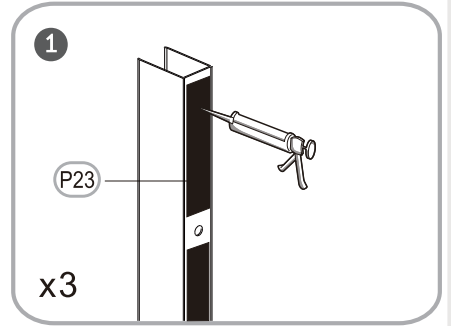
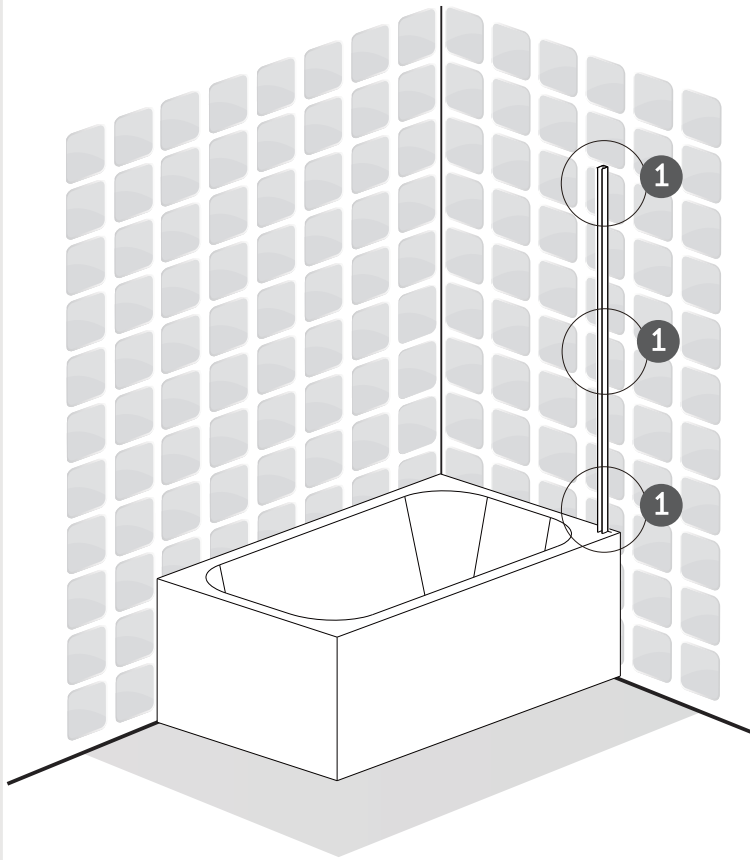
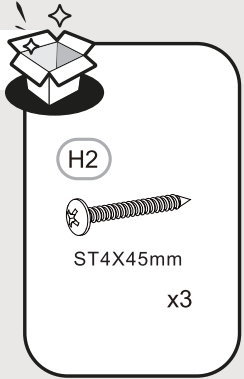



5

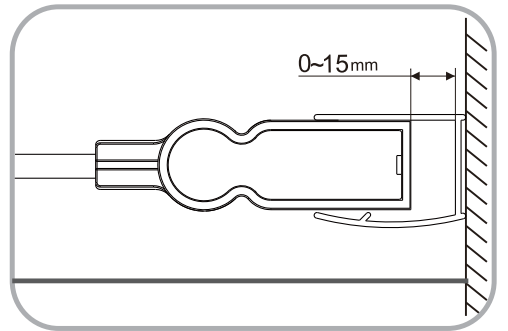
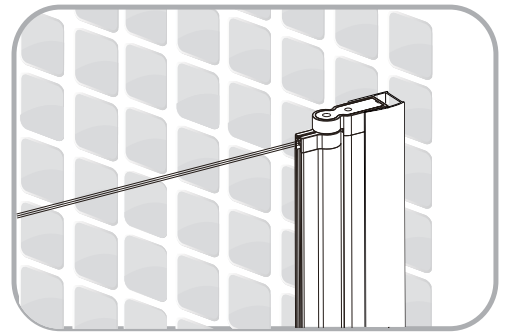
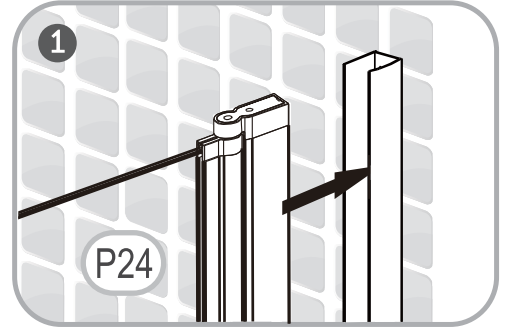
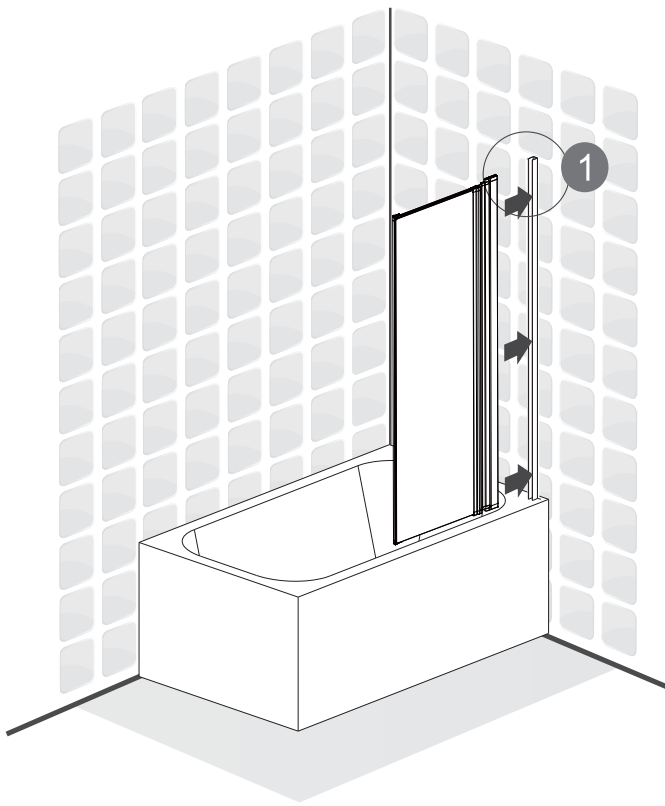
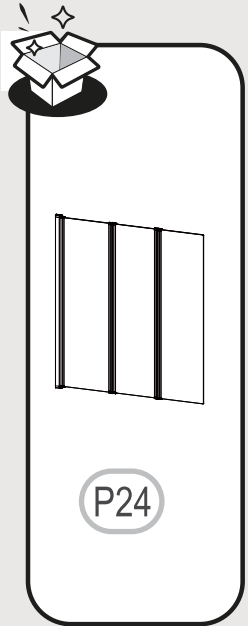



-
- H3

ST4x9.5 mm

x3
- H15

x3
- H14

x3

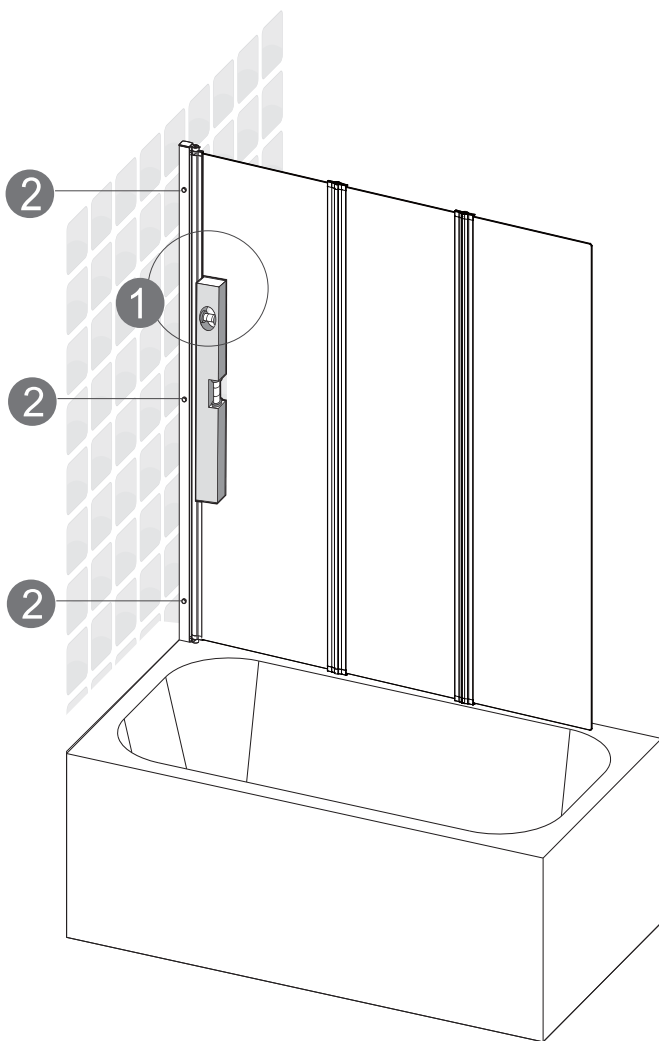
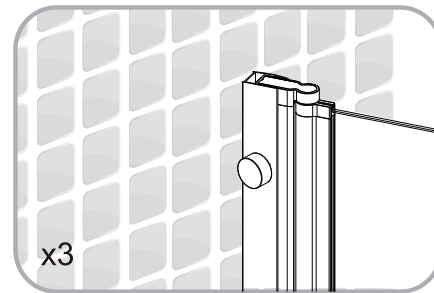
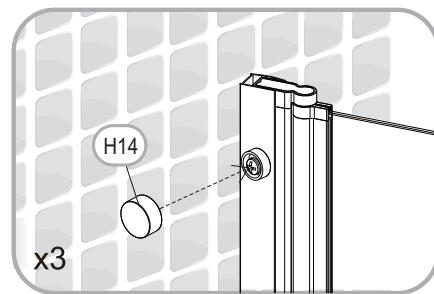
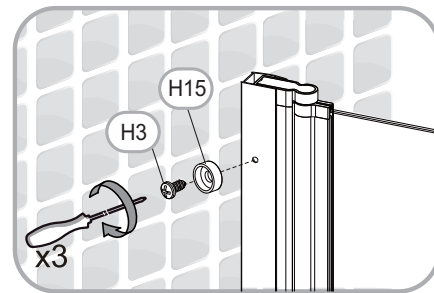
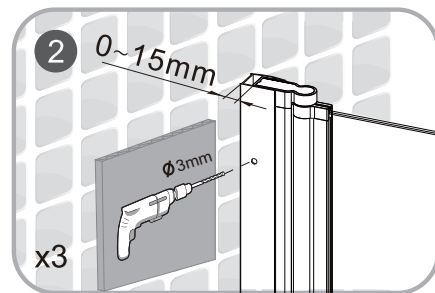
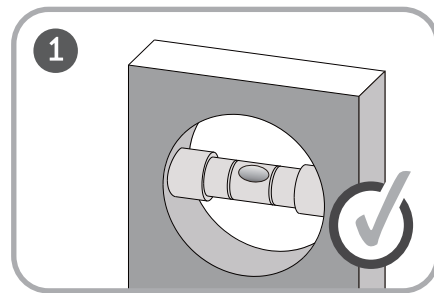
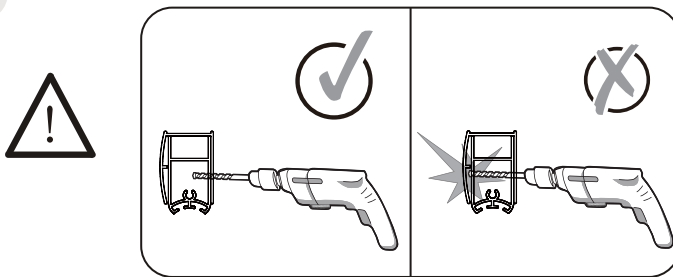

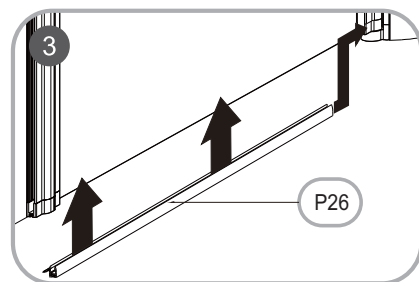
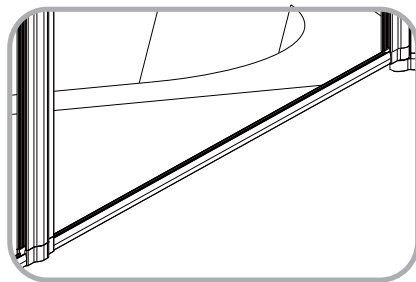
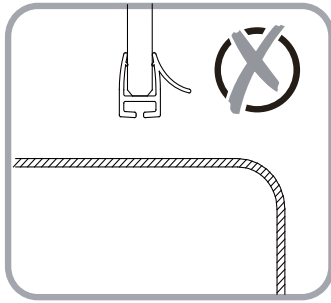
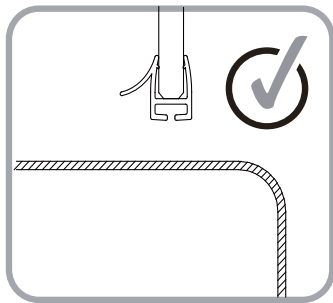
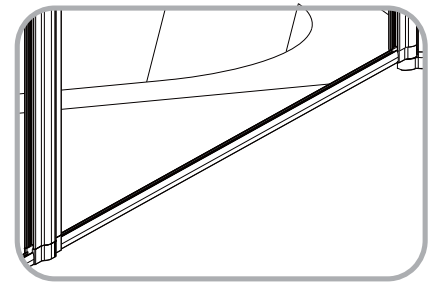
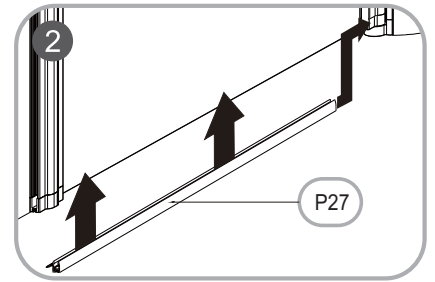
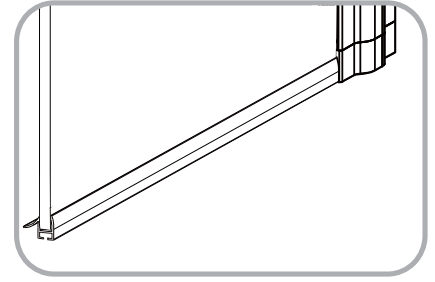
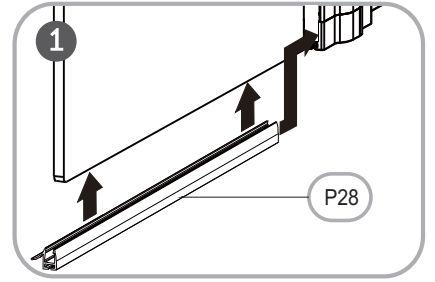
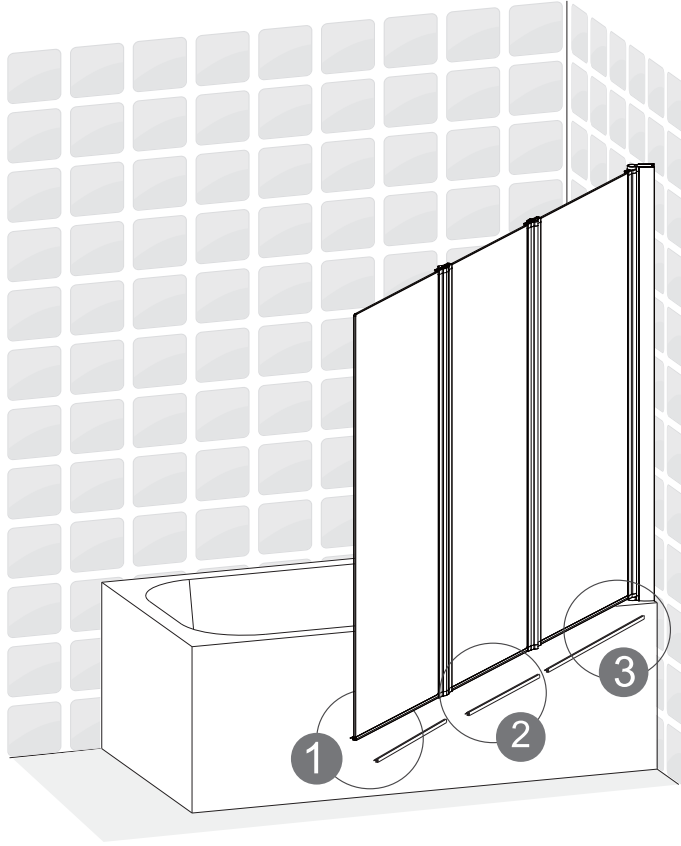
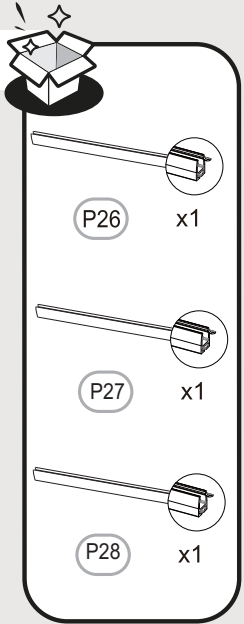

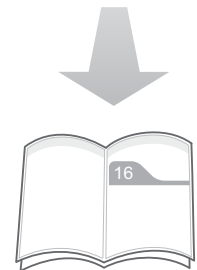
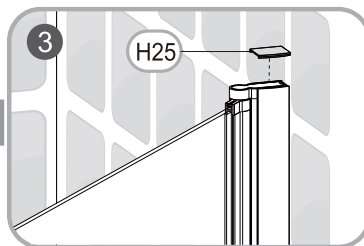
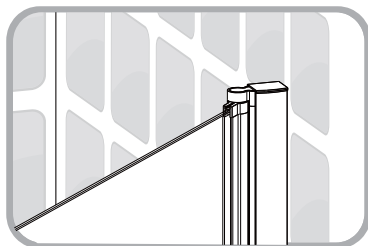
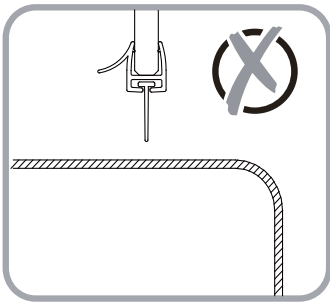
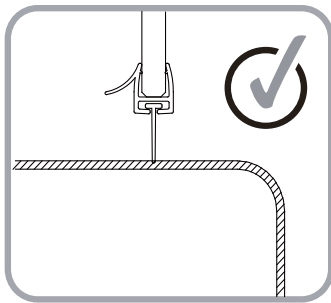
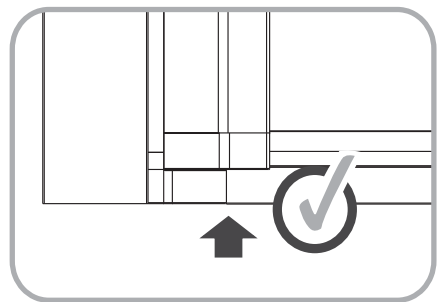
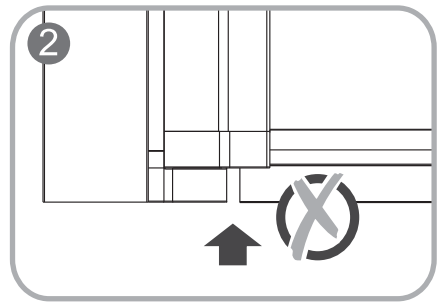
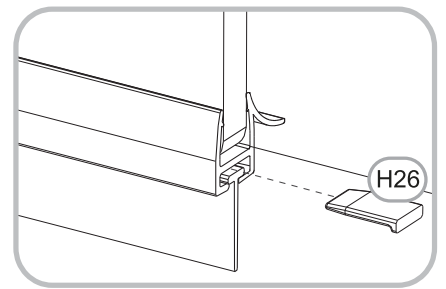
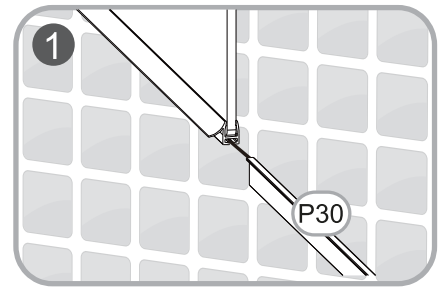
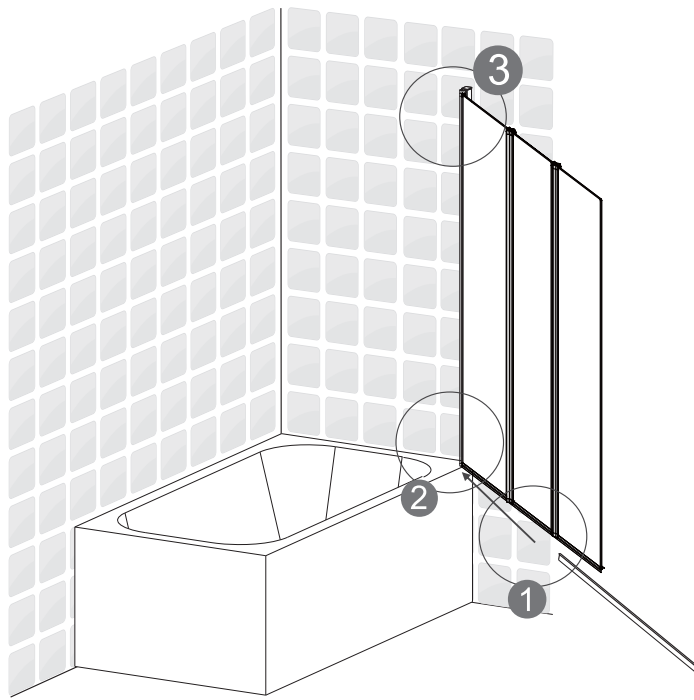
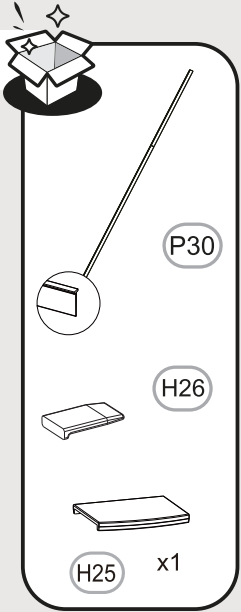



9

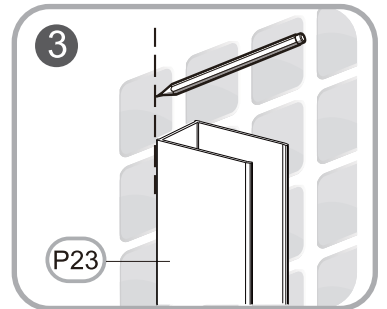
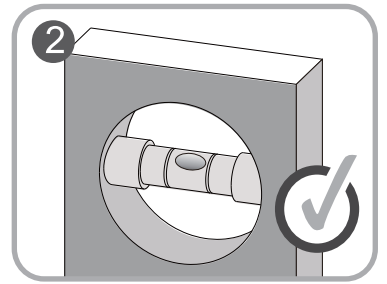
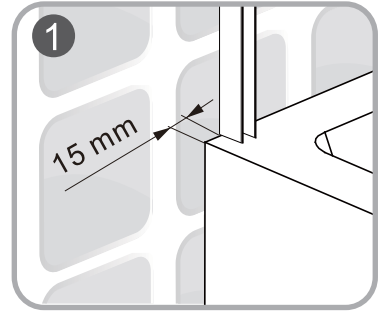
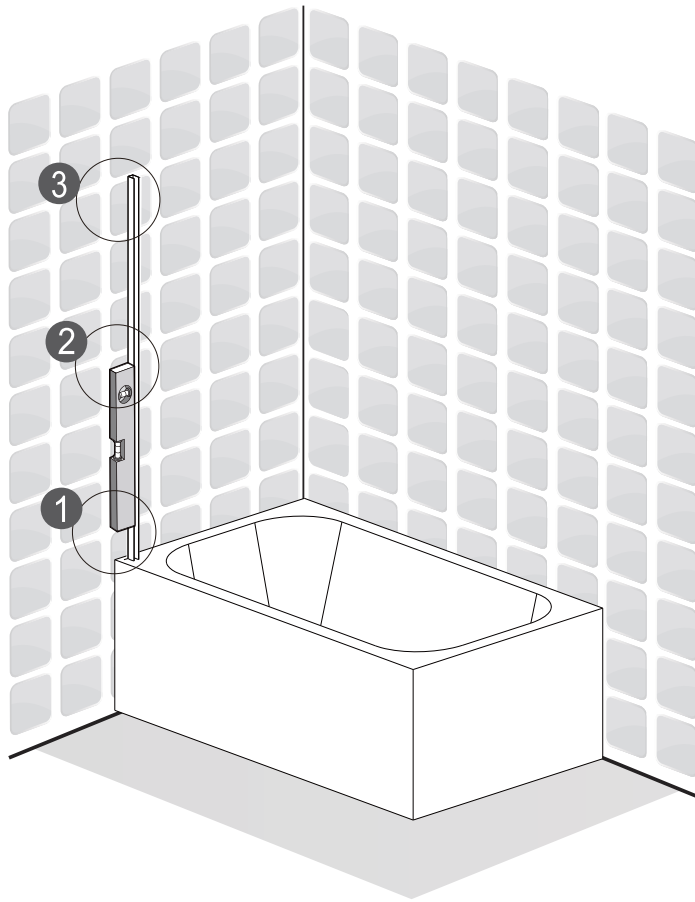
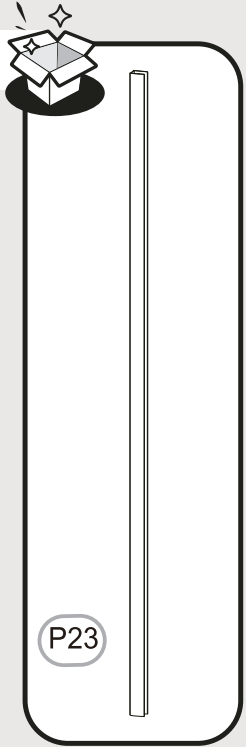

10

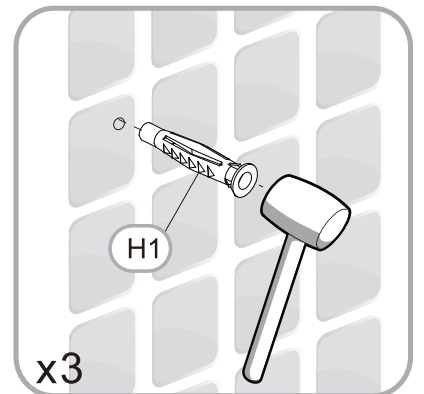
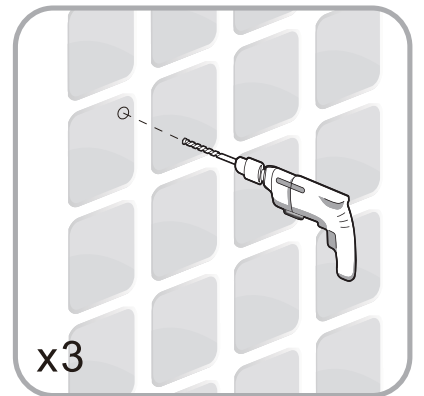
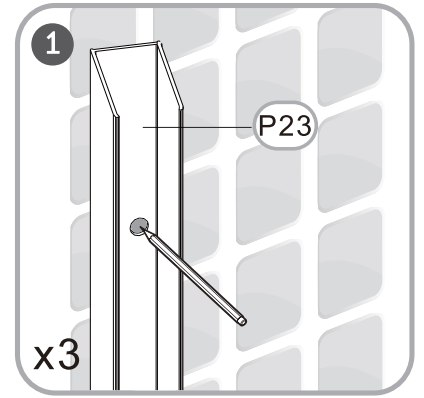
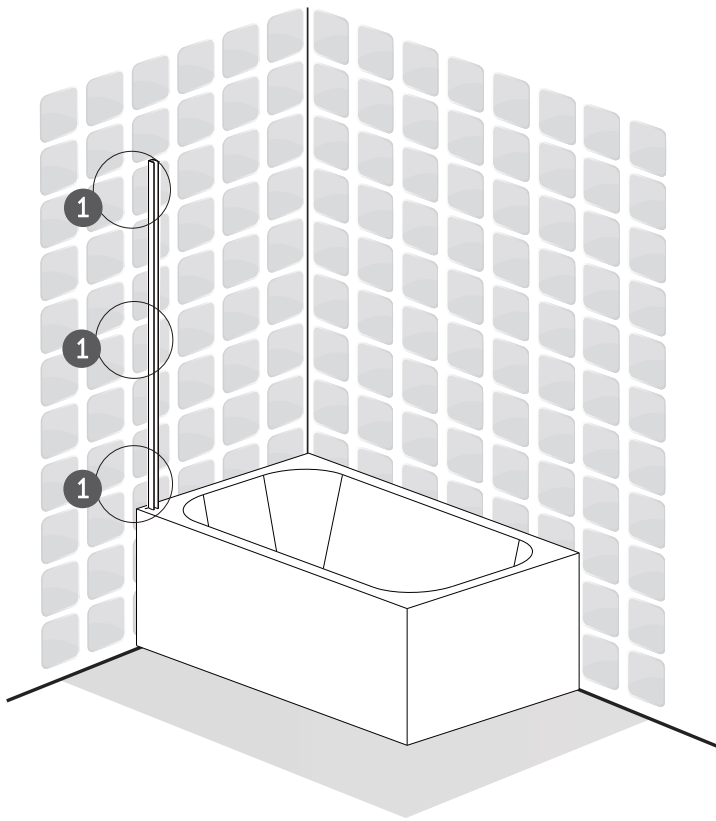
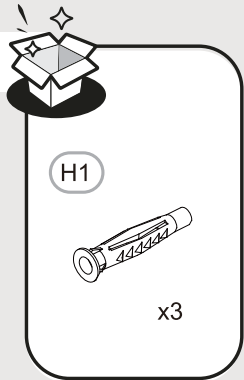
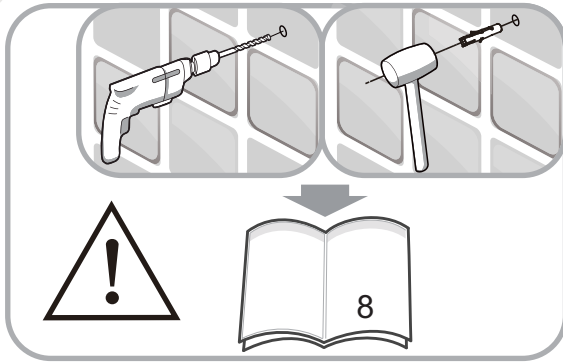

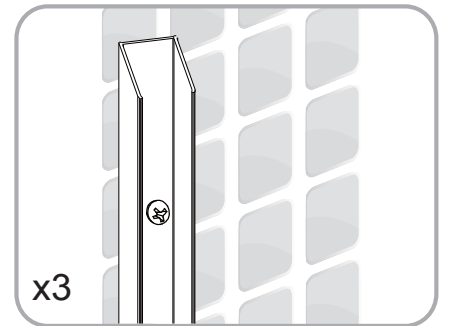
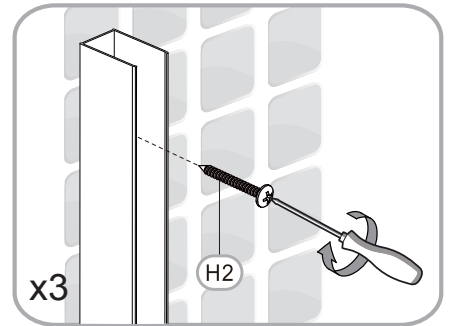
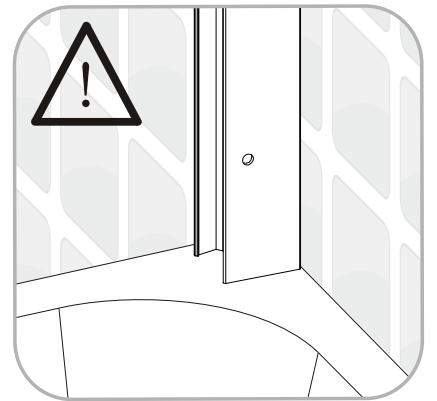
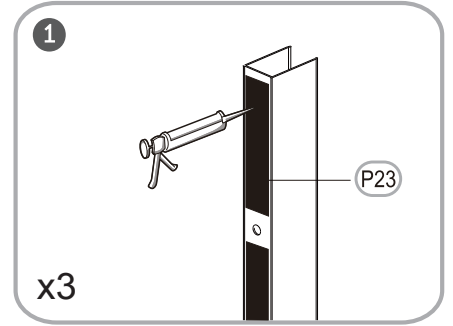
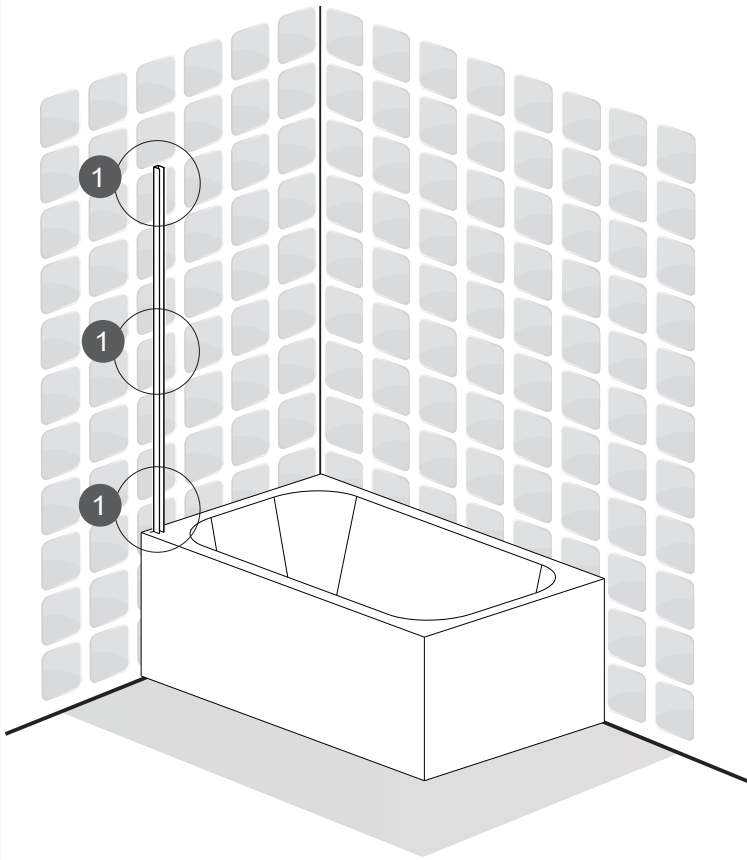
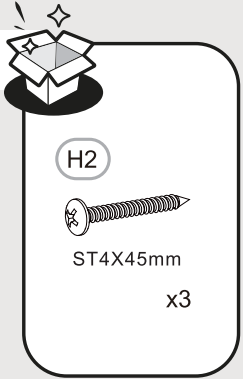





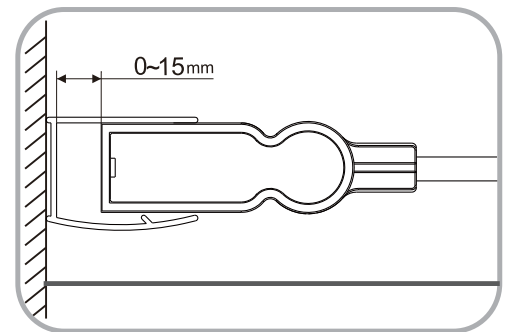
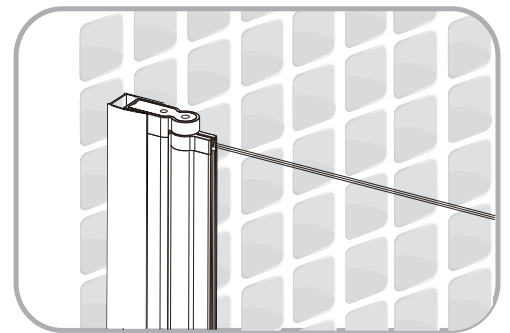
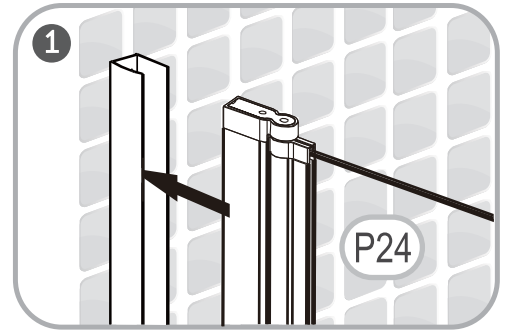
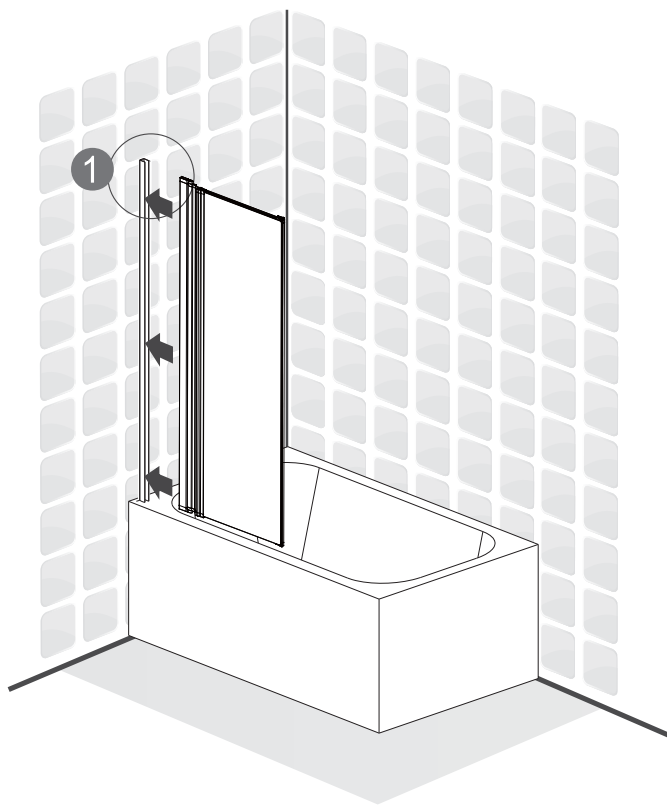
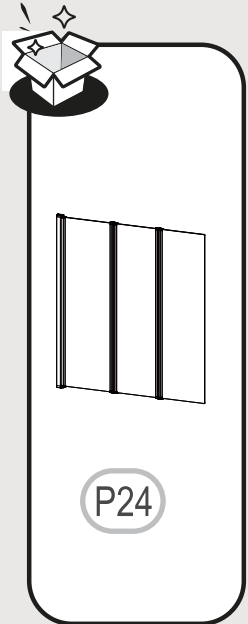

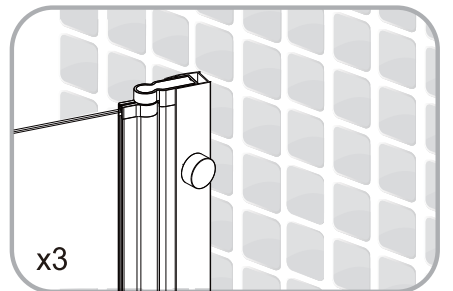
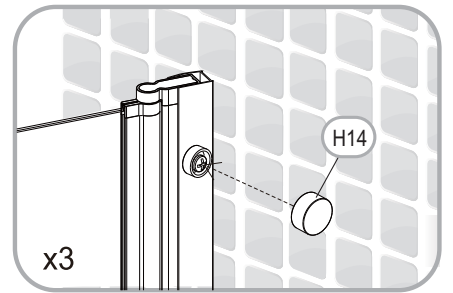
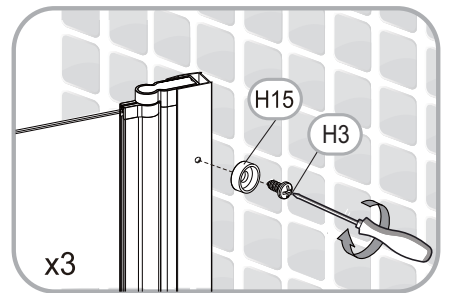
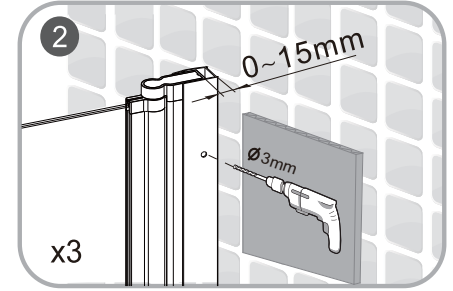
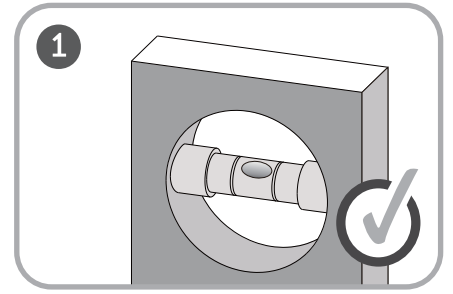
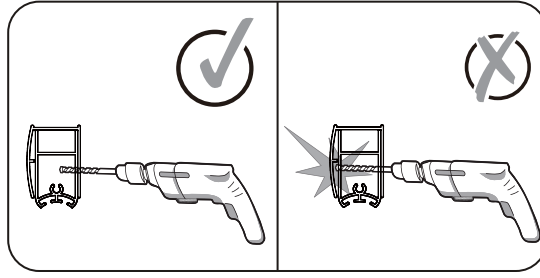
12



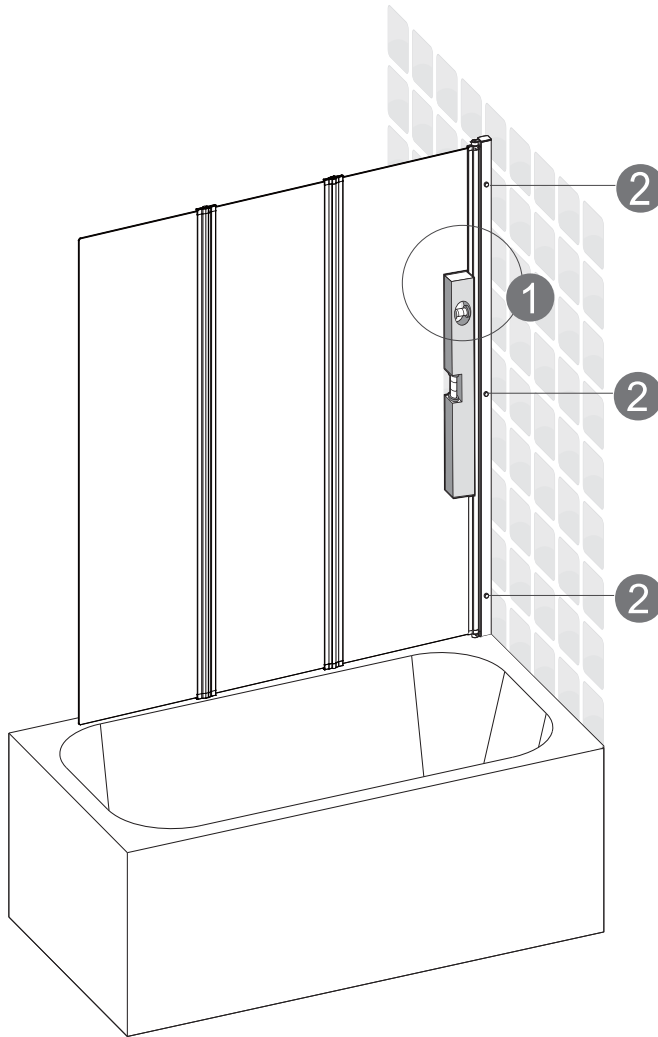

- H3

 ST4x9.5 mm
 x3
- H15

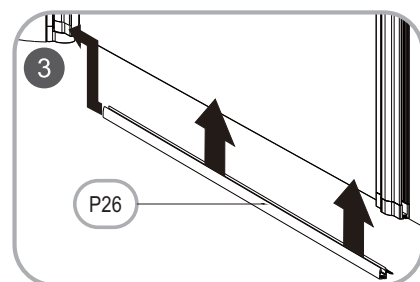
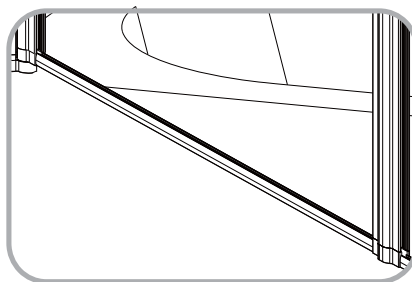
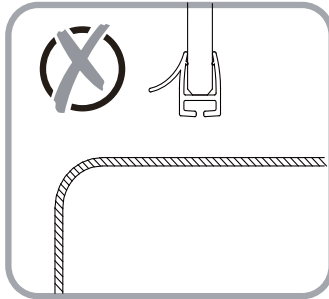
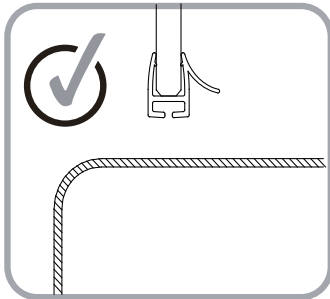
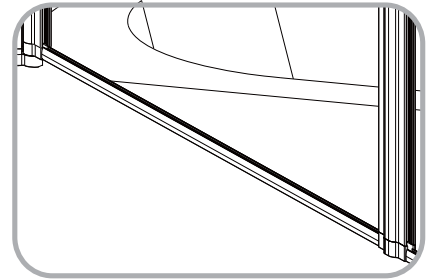
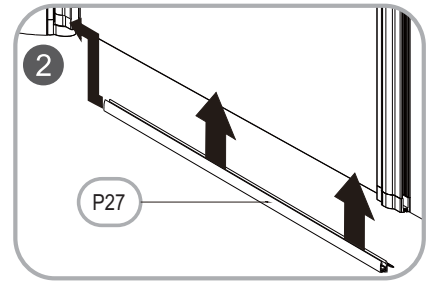
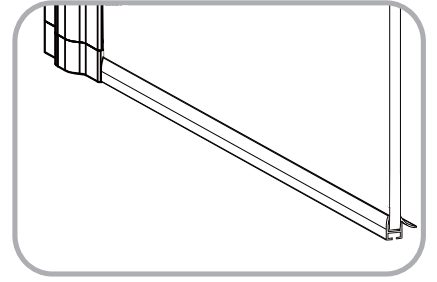
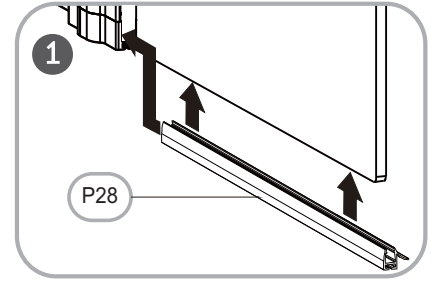
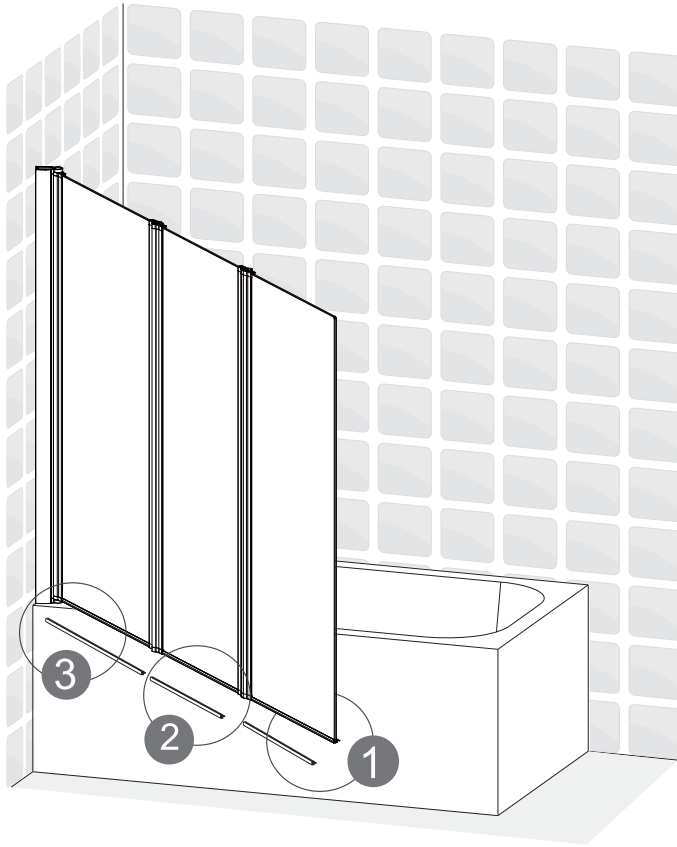
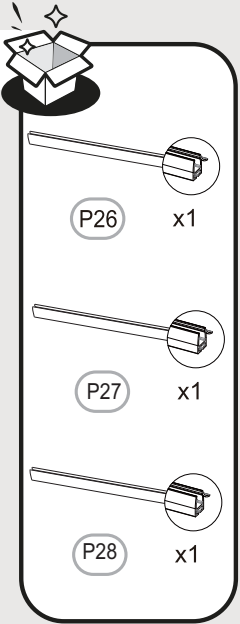
 x3
- H14

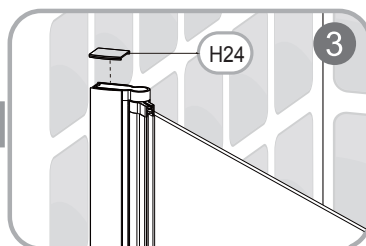
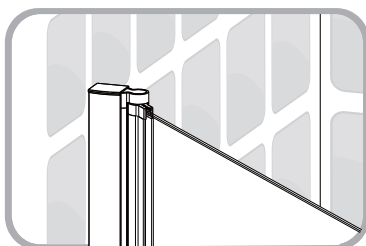
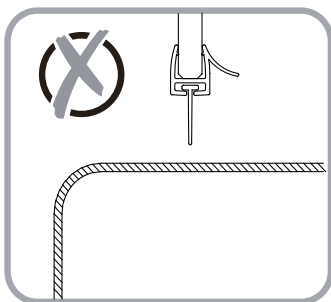
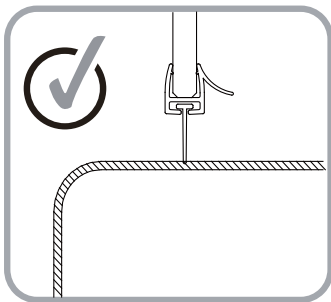
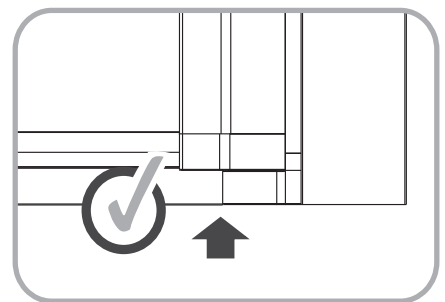
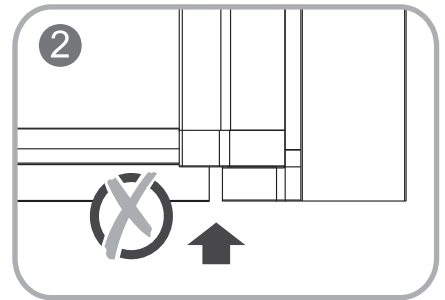
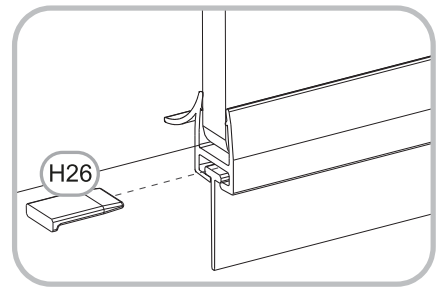
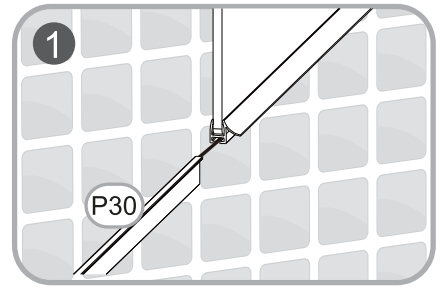
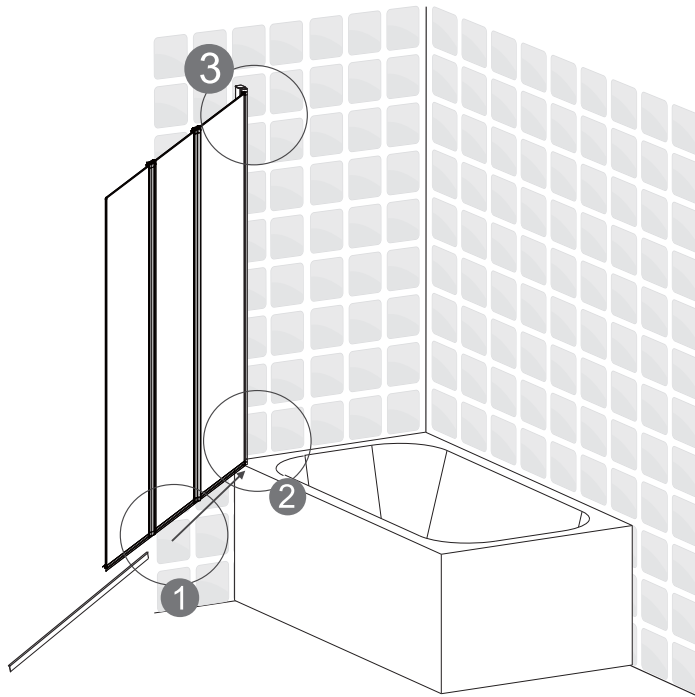
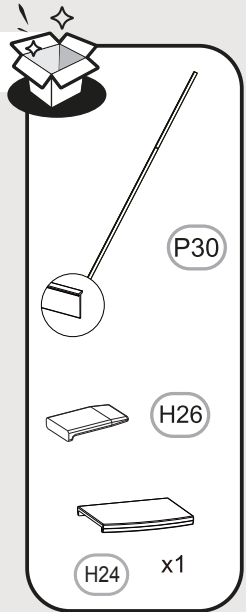
 x3









16

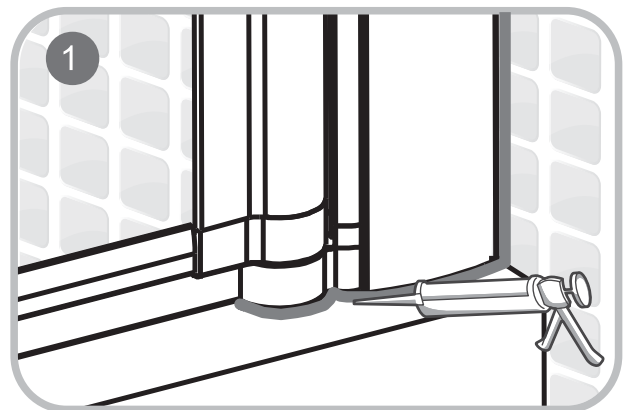
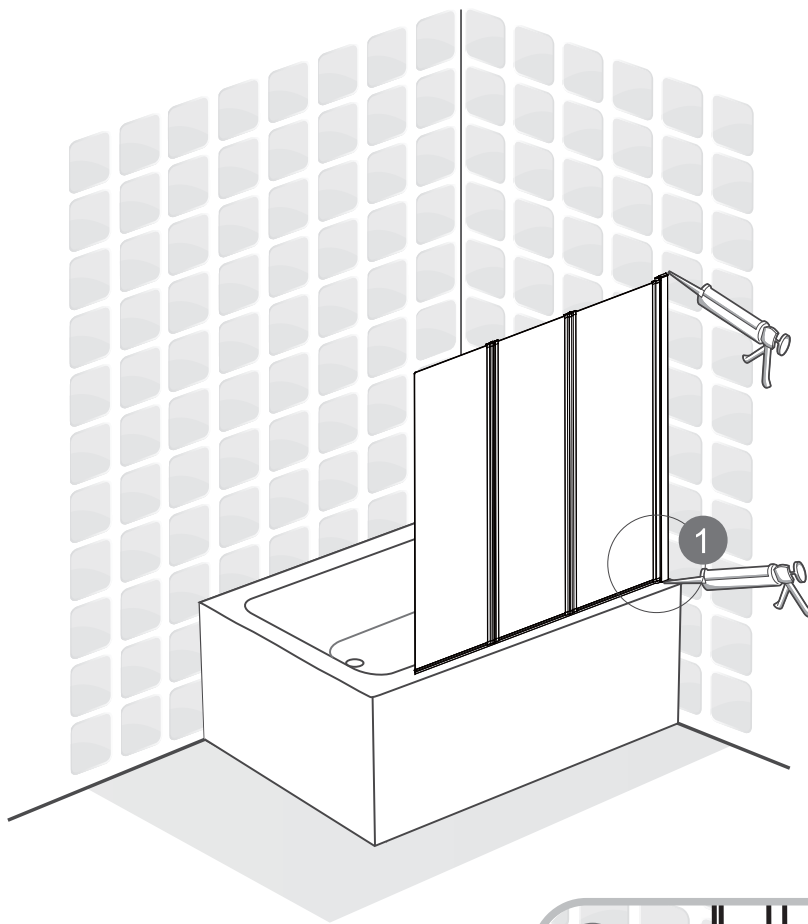
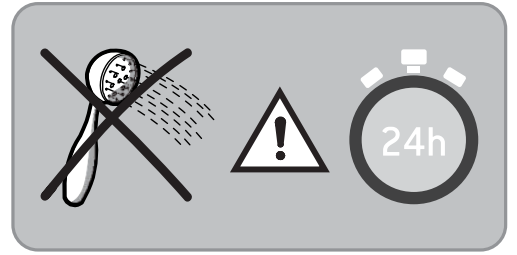

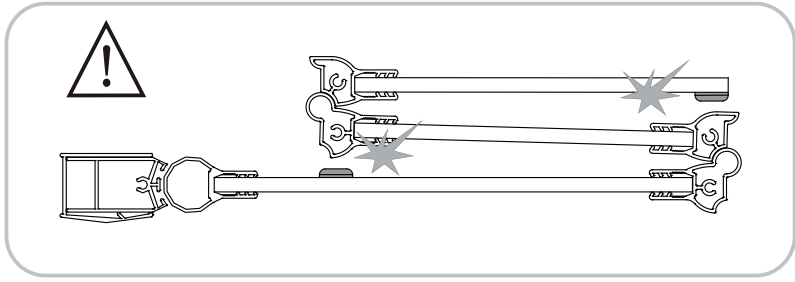

H10

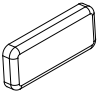

X2

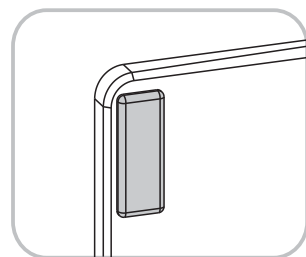
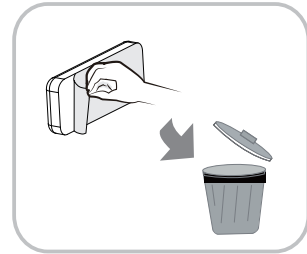
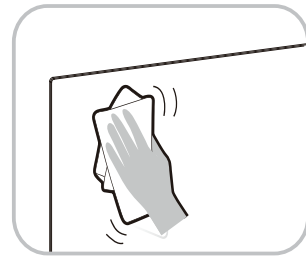
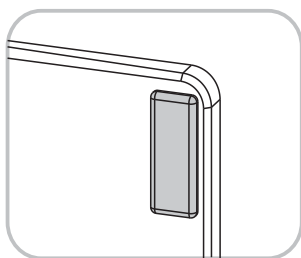
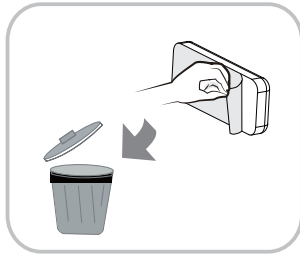
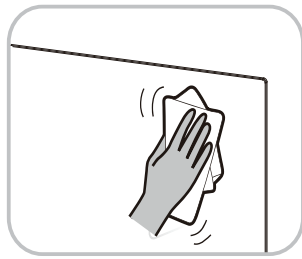
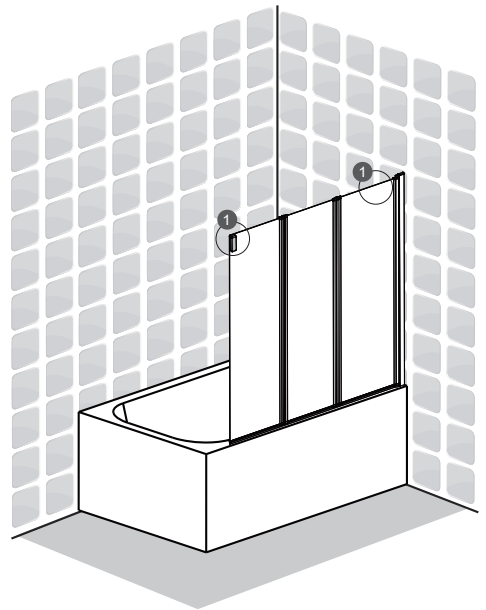
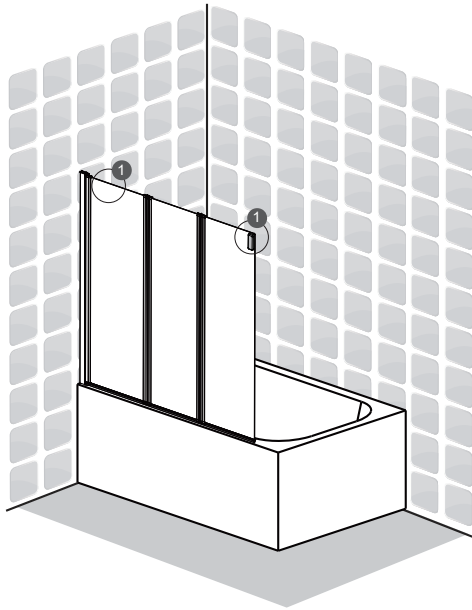



i



Eau claire / Agua limpia / Água limpa / Acqua pulita / Καθαρό νερό / Czysta woda / Чистая вода / Água limpa /
Чиста вода / Apa curata / таза су / Clean water



Sans solvant / Sin disolvente / Sem solventes / Senza solventi / Χωρίς διαλυτικά / Bez rozpuszczalnika / Без растворителя /
Sem solventes/ Без розчинника / Fara solvent / еріткішсіз / Solvent-free

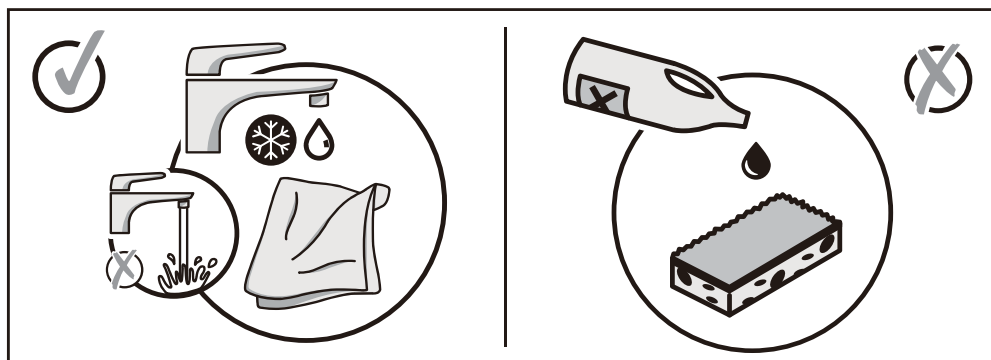
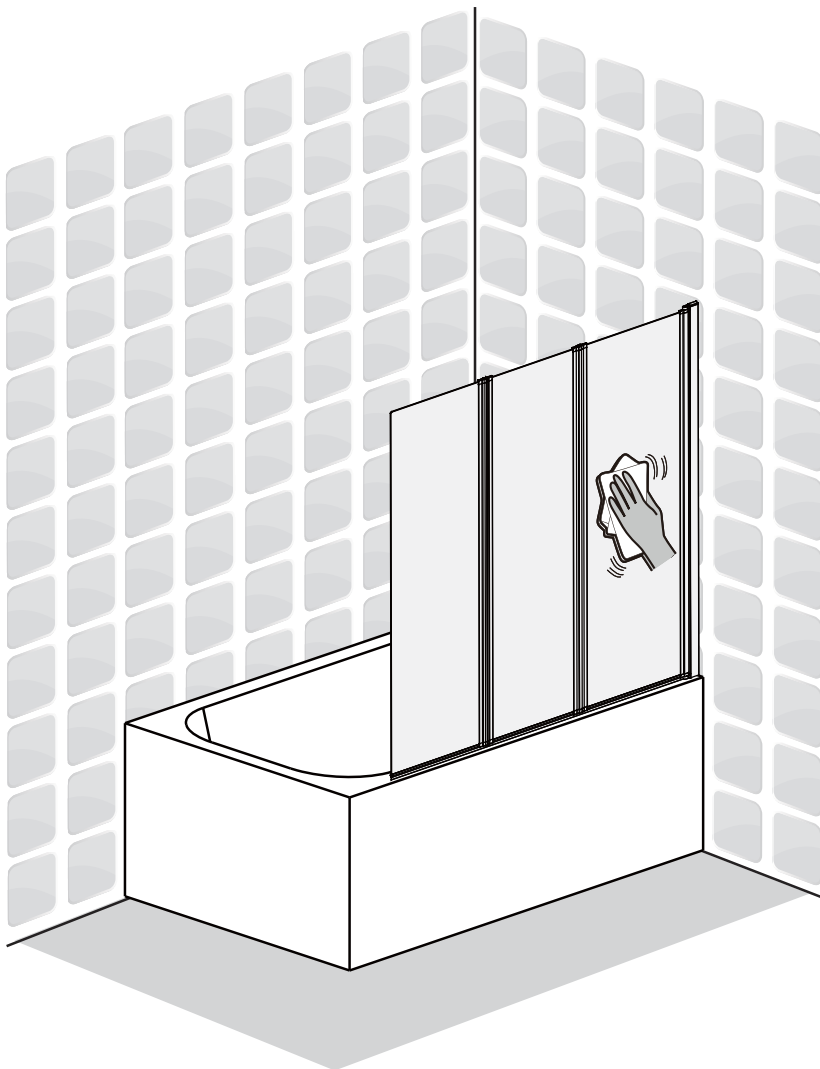



FR

CE

ADEO Services -135 Rue Sadi Carnot -
CS 00001 59790 RONCHIN - France
20
EN14428:2004+A1:2008

Code d'identification unique
du produit type: **

usage prévu: hygiène personnelle

Nettoyable: Conforme

Résistance à l'impact/
Capacité de Fragmentation: Conforme

durabilité: Conforme

DOP N ° *

ES

CE

ADEO Services -135 Rue Sadi Carnot -
CS 00001 59790 RONCHIN - France
20
EN14428:2004+A1:2008

Código de identificación
única del producto tipo: **

Uso previsto: higiene personal

Limpiable: Conforme

Resistencia al impacto/
Capacidad de fragmentación: Conforme

Durabilidad: Conforme

DOP N ° *

PT

CE

ADEO Services -135 Rue Sadi Carnot -
CS 00001 59790 RONCHIN - France
20
EN14428:2004+A1:2008

Código de identificação
único do produto-tipo: **

Utilização prevista: higiene pessoal

Limpeza: Conforme

Resistência ao impacto/
Capacidade de fragmentação: Conforme

Durabilidade: Conforme

DOP N ° *

IT

CE

ADEO Services -135 Rue Sadi Carnot -
CS 00001 59790 RONCHIN - France
20
EN14428:2004+A1:2008

Codice di identificazione
unico del prodotto-tipo: **

Uso previsto: igiene personale

Pulibile: Conforme

Resistenza agli urti/
Capacità di Frammentazione: Conforme

Durata: Conforme

DOP N ° *

EL

CE

ADEO Services -135 Rue Sadi Carnot -
CS 00001 59790 RONCHIN - France
20
EN14428:2004+A1:2008

Μοναδικός κωδικός ταυτοποίησης
του τύπου του προϊόντος: **

προβλεπόμενη χρήση: προσωπική υγιεινή

Δυνατότητα καθαρισμού: Σύμφωνα με

Αντοχή σε κρούση/ Ικανότητα κατάτμησης: Σύμφωνα με

Διάρκεια: Σύμφωνα με

DOP N ° *

PL

CE

ADEO Services -135 Rue Sadi Carnot -
CS 00001 59790 RONCHIN - France
20
EN14428:2004+A1:2008

Niepowtarzalny kod
identyfikacyjny typu wyrobu: **

przeznaczenie: higiena osobista

Możliwość czyszczenia: Zgodny

Odporność na uderzenia/
Rozkruszalność: Zgodny

Trwałość: Zgodny

DOP N ° *

RO

CE

ADEO Services -135 Rue Sadi Carnot -
CS 00001 59790 RONCHIN - France
20
EN14428:2004+A1:2008

Cod unic de identificare
a tipului de produs: **

destinație: igienă personală

Posibilitatea de curățare: Conform

Rezistență la impact/
Capacitate de fragmentare: Conform

Durabilitate: Conform

DOP N ° *

EN

CE

ADEO Services -135 Rue Sadi Carnot -
CS 00001 59790 RONCHIN - France
20
EN14428:2004+A1:2008

Unique identification code
of the product-type: **

intended use: personal hygiene

cleanability: Pass

Impact resistance/ shatter properties: Pass

Durability: Pass

DOP N ° *

* / **

FR Reportez-vous à l'annexe.

ES Consulte el apéndice.

PT Consulte o anexo.

IT Consultare l'appendice.

EL Ανατρέξτε στο Παράρτημα.

PL Patrz załącznik.

RO Consultați anexa.

EN Refer to appendix.

FR/ Annexe

ES/ Apéndice

PT/ Anexo

IT/ Appendice

EL/ Παράρτημα

PL/ Załącznik

RO/ Anexa

KZ/ қосымша

EN/ Appendix

EAN CODE	**MODEL NO.	SIZE (MM)	*DOP NUMBER
3276007112498	ESBS120SC	1200x1400 silver	098114/0030/2020
3276007112504	ESBS120SF	1200x1400 silver	098114/0030/2020



* Garantie 5 ans / 5 años de garantía / Garantia de 5 anos / Garanzia 5 Anni / Εγγύηση 5 ετών /
Gwarancja 5letnia / Гарантия 5 года / Кепілдік 5 жыл / Гарантія 5 років / Garanție 5 ani /
5-year guarantee

Made in P.R.C.

ADEO Services - 135 Rue Sadi Carnot - CS 00001
59790 RONCHIN - France

ТОВ «Леруа Мерлен Україна»,
вул. Полярна 17а, м. Київ 04201, Україна

ООО ЛЕРУА МЕРЛЕН ВОСТОК, 141031, Московская
область, Мытищинский район, г. Мытищи,
Осташковское шоссе, д.1, РОССИЯ

Importado e distribuído por LEROY MERLIN
CIA BRASILEIRA DE BRICOLAGEM
Rua Domingas Galleri Blotta, 315 - Interlagos - CEP
04455-360 São Paulo - SP - Brazil CNPJ: 01.438.784/0001-05
CALM (Central de Atendimento Leroy Merlin) -4020.5376 (capitais)
e 0800.0205376 (demais regiões)

Imported by Adeo South Africa (PTY) LTD T/A Leroy Merlin
Leroy Merlin Greenstone Store - Corner Blackrock Street
and Stoneridge Drive, Greenstone Park Ext 2,
Edenvale, 1610 - Johannesburg, Gauteng, South Africa

«Леруа Мерлен Қазақстан» ЖШС Қазақстан
Республикасы, 050000, Алматы қ., Қонаев
көшесі, 77, «ParkView» БО, 6қ., 07 оф.

