

EAN CODE: 3276007184204

- | | | | |
|--|---|---|--|
| FR Notice de Montage - Utilisation - Entretien | ES Instrucciones de Montaje, Utilización y Mantenimiento | PT Instruções de Montagem, Utilização e Manutenção | IT Istruzioni per il Montaggio, l'Uso e la Manutenzione |
| EL Εγχειρίδιο συναρμολόγησης, χρήσης και συντήρησης | PL Instrukcja Montażu, Użytkowania i Konserwacji | RU Руководство По Сборке и Эксплуатации | KZ Жинау, пайдалану және техникалық қызмет көрсету нұсқаулығы |
| UA Керівництво По Збірці і Експлуатації | RO Manual asamblare, utilizare și întreținere | BR Instruções de Montagem, Utilização e Manutenção | EN Assembly - Use - Maintenance Manual |

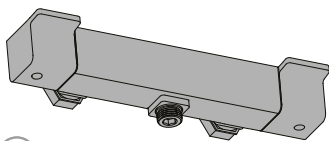

A

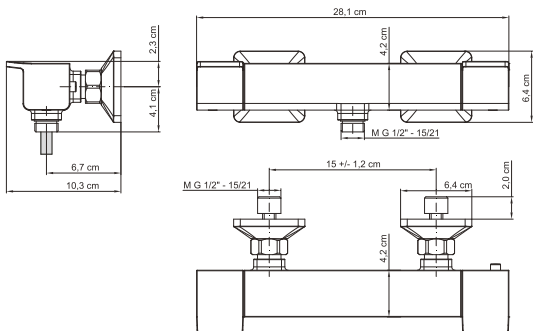
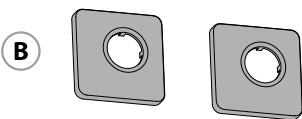

B



C



D



E



PH2





FR: Préparation / ES: Preparación / PT: Preparação / IT: Preparazione / EL: Προετοιμασία /
PL: Przygotowanie / RU: Подготовка / KZ: Дайындау / UA: Підготування / RO: Pregătire / BR: Preparação /
EN: Preparation



FR: Montage / ES: Montaje / PT: Montagem / IT: Montaggio / EL: Συναρμολόγηση /
PL: Montaż / RU: Сборка / KZ: Монтаждау / UA: Збірка / RO: Montaj / BR: Montagem /
EN: Assembly

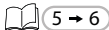

FR: Utilisation eau chaude-eau froide/ ES: Utilización agua caliente-agua fría/ PT: Utilização água quente-água fria/
IT: Uso acqua calda-acqua fredda/ EL: Χρήση ζεστού-κρύου νερού/ PL: Użytkowanie zimnej wody-gorącej wody/
RU: использование горячей и холодной воды/ KZ: Суық және ыстық суды қолдану/
UA: використання гарячої - холодної води/ RO: Utilizare apă caldă-apă rece/ BR: Uso de água quente e fria/
EN: Using hot and cold water



FR: Changement de cartouche/ ES: Cambio de cartucho/ IT: Cambio cartuccia/ PT: Mudança de cartucho/
EL: Αλλαγή φυσιγγίου/ PL: Wymiana wkładu / RU: Смена картриджа/ KZ: Картриджді ауыстыру/
UA: Заміна картриджа/ RO: Schimbare cartuş/ BR: Substituição de cartucho/ EN: Replacing the cartridge

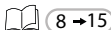

FR: Changement de mousseur/ ES: Cambio de aireador/ PT: Mudança de arejador/ IT: Cambio rompigitto/
EL: Αλλαγή αεράτορα / PL: Wymiana perlatora / RU: Смена аэратора/ KZ: Ауақанықтырғышты ауыстыру/
UA: Заміна аератора/ RO: Schimbare aerator/ BR: Substituição do aerador/ EN: Replacing the aerator





Min.:

1 Bar

Max.:

10 Bar



2-6,3* Bar

Max dif. COLD-HOT:

<2 Bar



Max.:

80 °C



65 °C



>250 kcal/min



>18 kW

FR:* Si la pression est supérieure à 5 bars, il est nécessaire de rajouter un réducteur de pression / **ES:*** Si la presión es superior a 5 bars, es necesario añadir un reductor de presión. / **PT:*** Se a pressão for superior a 5 bars, será necessário acrescentar um reductor de pressão / **IT:*** Se la pressione è superiore a 5 bar, bisogna aggiungere un riduttore di pressione / **EL:*** Εάν η πίεση υπερβαίνει τα 5 bars, είναι απαραίτητη η προσθήκη μειωτή πίεσης / **PL:*** Jeżeli ciśnienie jest wyższe niż 5 barów, należy dodać reductor ciśnienia / **RU:*** Если давление превышает 5 бар, необходимо добавить редуктор давления / **KZ:*** Егер қысым 5 бардан асатын болса, қысым бәсеңдеткішін қосу қажет / **UA:*** Якщо тиск перевищує 5 бар, необхідно додати редуктор тиску / **RO:*** Dacă presiunea este mai mare de 5 bari, este necesar să adăugați un reductor de presiune / **BR:*** Se a pressão for superior a 5 bar, é necessário adicionar um reductor de pressão / **EN:*** If the pressure is over 5 bars, a pressure reducing valve must be added.



FR: Préparation / ES: Preparación / PT: Preparação / IT: Preparazione / EL: Προετοιμασία /
PL: Przygotowanie / RU: Подготовка / KZ: Дайындау / UA: Підготовка / RO: Pregătire /
BR: Preparação / EN: Preparation

1

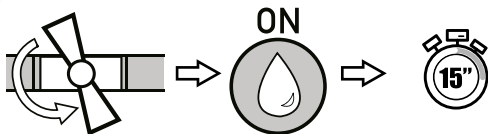

2

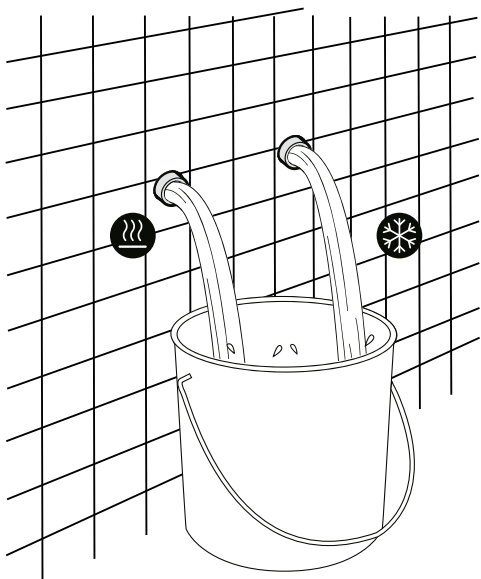

3

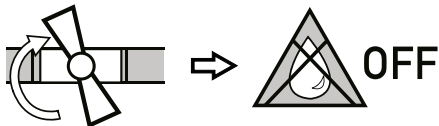

FR: Montage / ES: Montaje / PT: Montagem / IT: Montaggio / EL: Συναρμολόγηση /
PL: Montaż / RU: Сборка / KZ: Монтаждау / UA: Збірка / RO: Montaj / BR: Montagem /
EN: Assembly

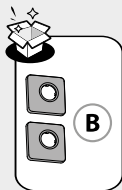
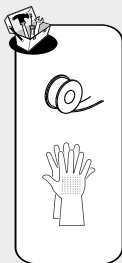
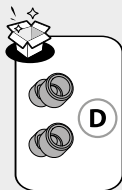

1

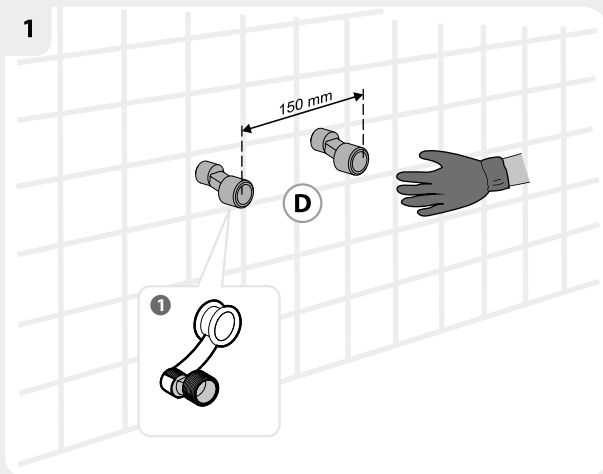

2

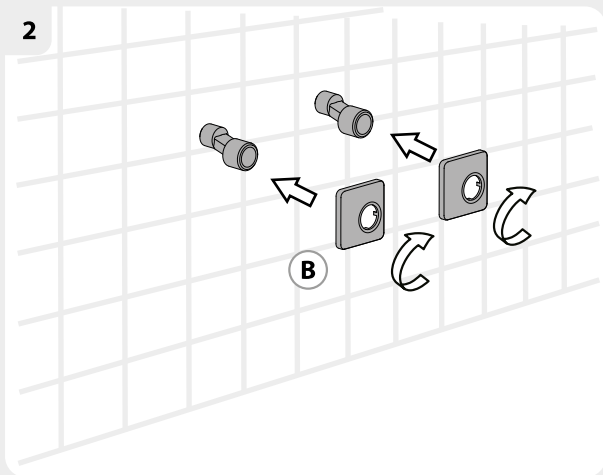



FR: Montage / ES: Montaje / PT: Montagem / IT: Montaggio / EL: Συναρμολόγηση /
PL: Montaż / RU: Сборка / KZ: Монтаждау / UA: Збірка / RO: Montaj / BR: Montagem /
EN: Assembly

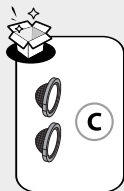

3

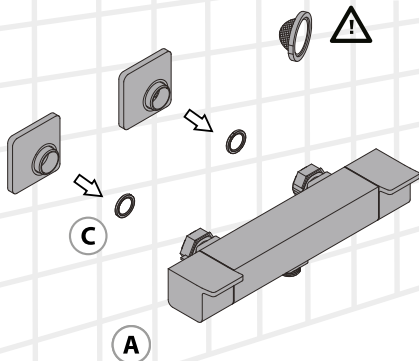

4

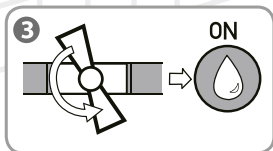
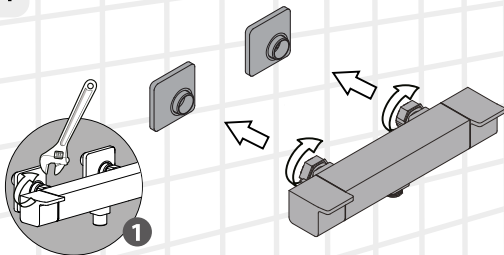

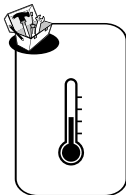

FR: Montage / ES: Montaje / PT: Montagem / IT: Montaggio / EL: Συναρμολόγηση /
PL: Montaż / RU: Сборка / KZ: Монтаждау / UA: Збірка / RO: Montaj / BR: Montagem /
EN: Assembly

5

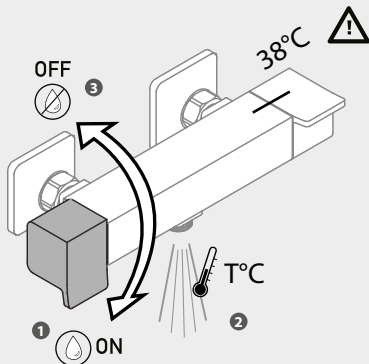

$T^{\circ}\text{C} \approx 38^{\circ}\text{C}$ → OK →  10

$T^{\circ}\text{C} \neq 38^{\circ}\text{C}$ →  9

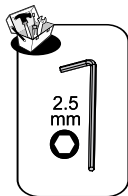

FR: Montage / ES: Montaje / PT: Montagem / IT: Montaggio / EL: Συναρμολόγηση /
 PL: Montaż / RU: Сборка / KZ: Монтаждау / UA: Збірка / RO: Montaj / BR: Montagem /
 EN: Assembly

1

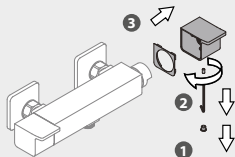

2

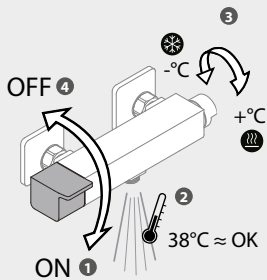

3

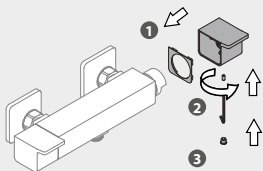

4

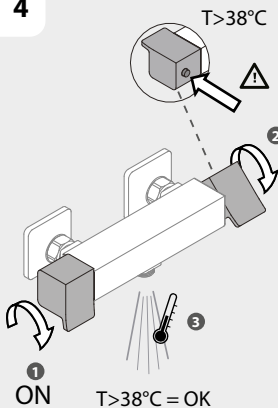



FR: Utilisation eau chaude-eau froide/ ES: Utilización agua caliente-agua fría/ PT: Utilização água quente-água fria/
IT: Uso acqua calda-acqua fredda/ EL: Χρήση ζεστού-κρύου νερού/ PL: Użytkowanie zimnej wody-gorącej wody/
RU: использование горячей и холодной воды/ KZ: Суық және ыстық суды қолдану/
UA: використання гарячої - холодної води/ RO: Utilizare apă caldă-apă rece/ BR: Uso de água quente e fria/
EN: Using hot and cold water

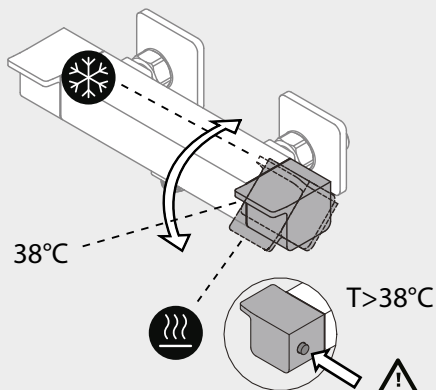
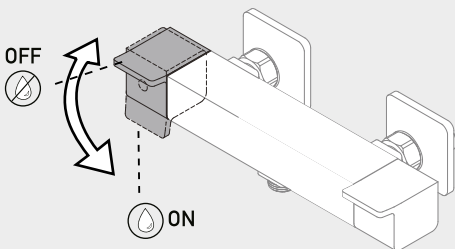

No.	EAN	QTY
	3276007184204	
1	0802529CR	1
2	0731975	2
3	0621623	2
4	0631460	2
5	0623912	1
6	0733178T	1
7	0805939	1
8	0802773	1
9	0659167	2
10	0731644	2
11	717511CR	1
12	0631448	3

No.	EAN	QTY
	3276007184204	
13	0723559CR	1
14	0801858CR	1
15	0802772	1
16	0633417	1
17	0724313CR	1
18	0899043	2
19	0752921TC	2
20	0733299CR	2
21	0671287	2
22	0761513CR	2
23	0899569	2
24	0751305CR	2
25	0615910	1

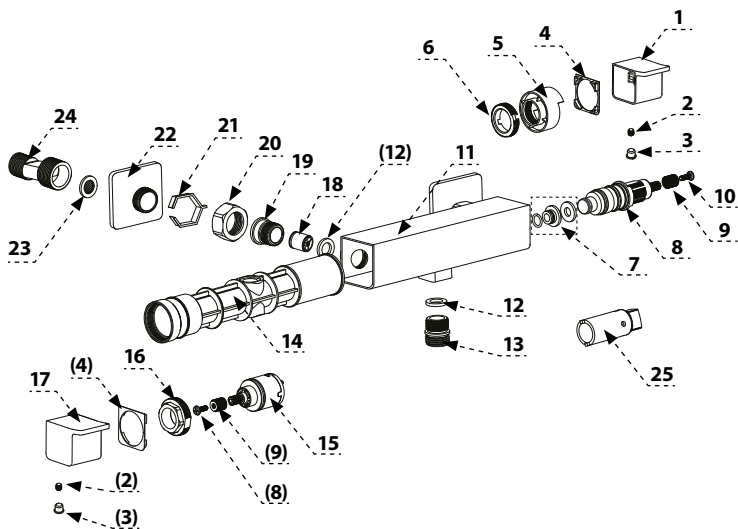

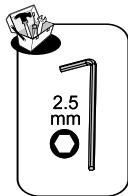

FR: Changement de cartouche/ ES: Cambio de cartucho/ IT: Cambio cartuccia/ PT: Mudança de cartucho/
EL: Αλλαγή φουσιγγίου/ PL: Wymiana wkładu / RU: Смена картриджа/ KZ: Картриджді ауыстыру/
UA: Заміна картриджа/ RO: Schimbare cartuş/ BR: Substituição de cartucho/ EN: Replacing the cartridge

1

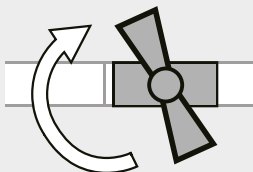

2

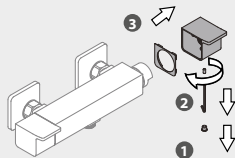

3



4

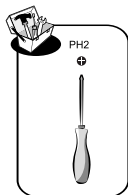
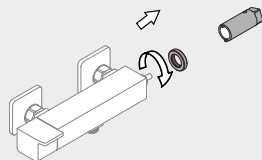



FR: Changement de cartouche/ **ES:** Cambio de cartucho/ **IT:** Cambio cartuccia/ **PT:** Mudança de cartucho/
EL: Αλλαγή φουσιγγίου/ **PL:** Wymiana wkładu / **RU:** Смена картриджа/ **KZ:** Картриджді ауыстыру/
UA: Заміна картриджа/ **RO:** Schimbare cartuş/ **BR:** Substituição de cartucho/ **EN:** Replacing the cartridge

5

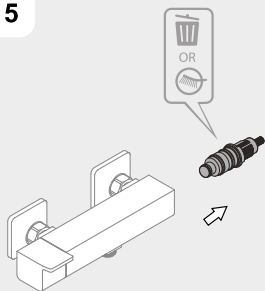

6

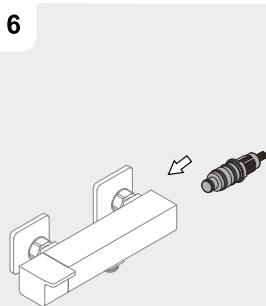

7

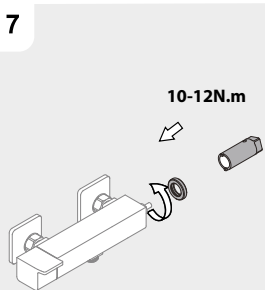

8

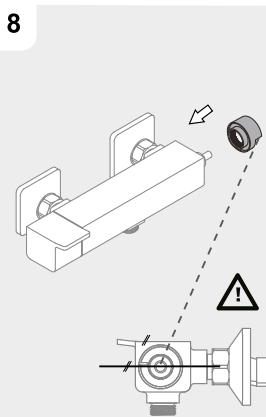

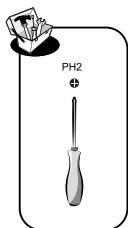

FR: Changement de cartouche/ ES: Cambio de cartucho/ IT: Cambio cartuccia/ PT: Mudança de cartucho/
 EL: Αλλαγή φουσιγγίου/ PL: Wymiana wkładu / RU: Смена картриджа/ KZ: Картриджді ауыстыру/
 UA: Заміна картриджа/ RO: Schimbare cartuş/ BR: Substituição de cartucho/ EN: Replacing the cartridge

9

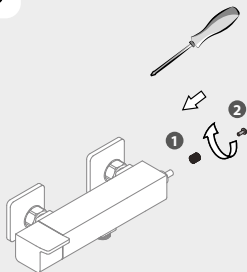

10

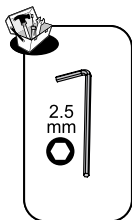
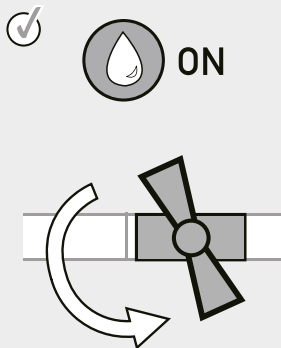

11

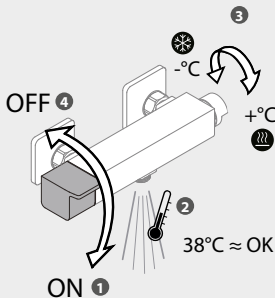

12

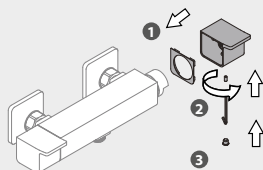



FR: Changement de cartouche/ ES: Cambio de cartucho/ IT: Cambio cartuccia/ PT: Mudança de cartucho/
EL: Αλλαγή φιασίγγιου/ PL: Wymiana wkładu / RU: Смена картриджа/ KZ: Картриджді ауыстыру/
UA: Заміна картриджа/ RO: Schimbare cartuş / BR: Substituição de cartucho/ EN: Replacing the cartridge

13

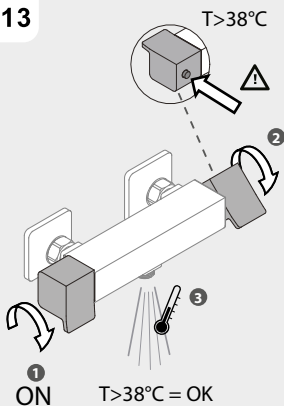

14

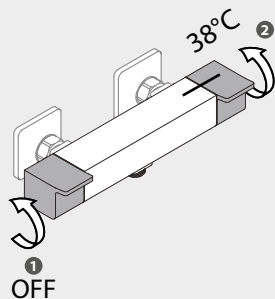

1



OFF

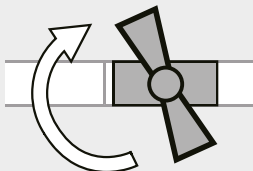

2

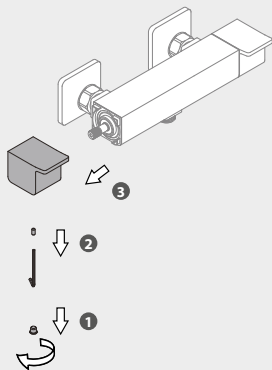



FR: Changement de cartouche/ ES: Cambio de cartucho/ IT: Cambio cartuccia/ PT: Mudança de cartucho/
EL: Αλλαγή φιαγγίου/ PL: Wymiana wkładu / RU: Смена картриджа/ KZ: Картриджді ауыстыру/
UA: Заміна картриджа/ RO: Schimbare cartuş/ BR: Substituição de cartucho/ EN: Replacing the cartridge

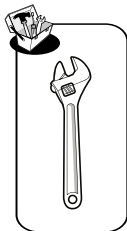
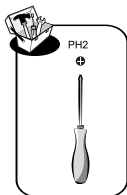

3

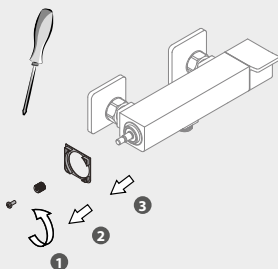

4

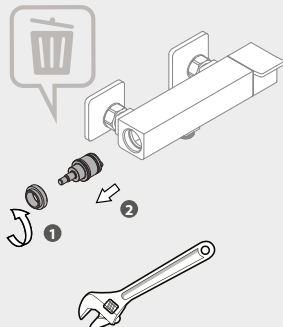

5

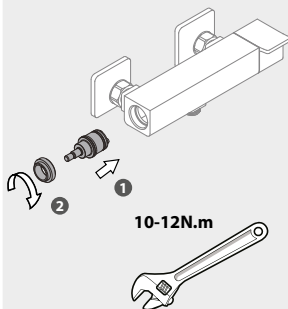

6

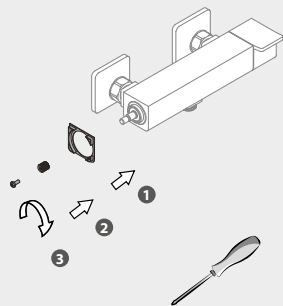



FR: Changement de cartouche/ **ES:** Cambio de cartucho/ **IT:** Cambio cartuccia/ **PT:** Mudança de cartucho/
EL: Αλλαγή φουσιγγίου/ **PL:** Wymiana wkładu / **RU:** Смена картриджа/ **KZ:** Картриджді ауыстыру/
UA: Заміна картриджа/ **RO:** Schimbare cartuş/ **BR:** Substituição de cartucho/ **EN:** Replacing the cartridge

7

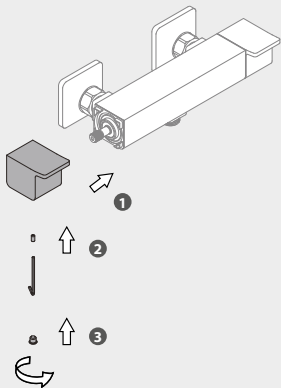

8

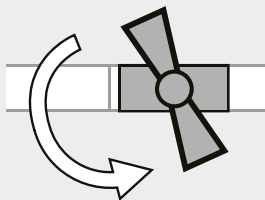



Eau claire / Agua limpia / Água limpa / Acqua pulita / Καθαρό νερό / Czysta woda / Чистая вода / Água limpa / Чиста вода / Ara curata / таза су / Clean water



Sans solvant / Sin disolvente / Sem solventes / Senza solventi / Χωρίς διαλυτικά / Bez rozpuszczalnika / Без растворителя / Sem solventes / Без розчинника / Fara solvent / еріткішчиз / Solvent-free

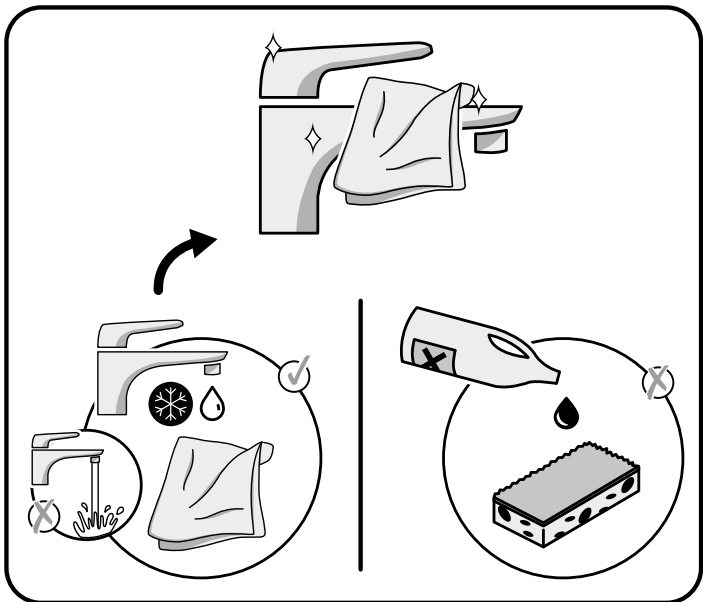



- FR** Attestation de conformité sanitaire
- ES** Certificado de conformidad sanitaria.
- PT** Atestado de conformidade sanitária.
- IT** Certificato di conformità sanitaria.
- EL** Βεβαίωση υγειονομικής συμμόρφωσης.
- PL** Certyfikat zgodności sanitarnej.
- RU** Декларация о соответствии санитарным нормам
- KZ** Санитарлық талаптарға сәйкестік декларациясы
- UA** Декларація про відповідність санітарним нормам
- RO** Atestat de conformitate sanitară
- BR** Certificado de conformidade sanitária.
- EN** Declaration of sanitary conformity.



* Garantie 10 ans / 10 años de garantía / Garantia de 10 anos / Garanzia 10 Anni / Εγγύηση 10 ετών /
Gwarancja 10-letnia / Гарантия 10 года / Кепілдік 10 жыл / Гарантія 10 років / Garantie 10 anni /
10-year guarantee

FR ADEO Services - 135 Rue Sadi Carnot - CS 00001
59790 RONCHIN - France

UA ТОВ «Леруа Мерлен Україна»,
вул. Полярна 17а, м. Київ 04201, Україна

RU ООО ЛЕРУА МЕРЛЕН ВОСТОК, 141031, Московская
область, г. Мытищи, Осташковское шоссе, д.1, РОССИЯ

BR Importado e distribuido por LEROY MERLIN
CIA BRASILEIRA DE BRICOLAGEM
Rua Domingos Galleteri Blotta, 315 - Interlagos - CEP
04455-360 São Paulo - SP - Brazil CNPJ: 01.438.784/0001-05
CALM (Central de Atendimento Leroy Merlin) -4020.5376 (capitais)
e 0800.0205376 (demais regiões)

SA Imported by Adeo South Africa (PTY) LTD T/A Leroy Merlin
Leroy Merlin Greenstone Store - Corner Blackrock Street
and Stoneridge Drive, Greenstone Park Ext 2,
Edenvale, 1610 - Johannesburg, Gauteng, South Africa

KZ «Леруа Мерлен Қазақстан» ЖШС Қазақстан
Республикасы, 050000, Алматы қ., Қонаев
көшесі, 77, «ParkView» БО, 6к., 07 оф.



Made in ITALY