

# & Inspire

TOKYO

EAN : 3276007691856 / 3276007691818  
Ref : PMC52A-3-1LA(WH) / PMC52A-3-1LA(SL)

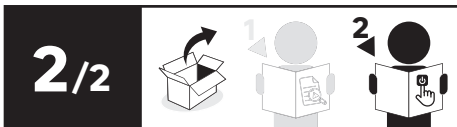
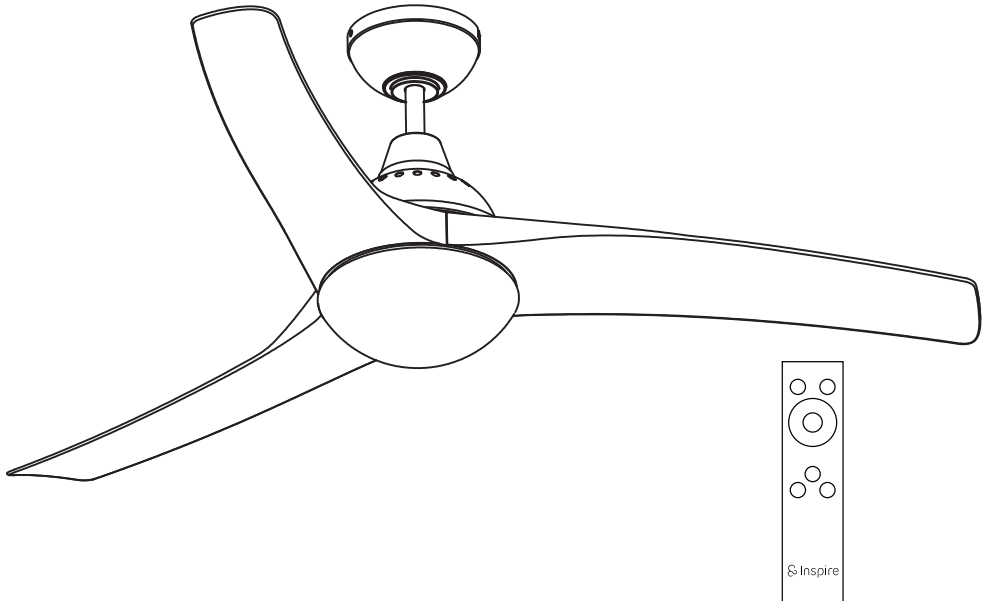

2025-01-V01

FR - Manuel d'Instructions

ES - Manual de Instrucciones

PT - Manual de Instruções

IT - Manuale di Istruzioni

EL - Εγχειρίδιο Οδηγιών

PL - Instrukcja Obsługi

UA - Інструкція з Експлуатації

RO - Manual de Instrucțiuni

BR - Manual de Instrução

NL - Handleiding

DE - Anleitung Handbuch

EN - Instructions Manual

\*Année de garantie / años de garantía / Ano de garantia / Anno di garanzia / Έτος εγγύησης / Rok gwarancji / Гарантія років / Anul de garanție / Anos de garantía / Garantiejaar / Jahr der Garantie / Year of guarantee

\*\*réparable / reparabile / reparável / riparabile / διορθώσιμος / naprawiany / ремонтний / reparabil / reparaturfähig / reparável / herstelbaar / reparierbar / repairable



**FR** : assemblage / **ES** : ensamblaje / **PT** : montagem / **IT** : assemblaggio /  
**EL** : συναρμολόγηση / **PL** : montaż / **UA** : збірка / **RO** : asamblare /  
**BR** : montagem / **NL** : samenstelling / **DE** : Montage / **EN** : assembly



**FR** : Utilisation / **ES** : Uso / **PT** : Utilização / **IT** : Utilizzo  
**EL** : Χρήση / **PL** : Użycie / **UA** : Використання / **RO** : Utilizare /  
**BR** : Utilização / **NL** : Gebruik / **DE** : Verwendung / **EN** : Use

**FR** : CARACTÉRISTIQUES TECHNIQUES / **ES** : CARACTERÍSTICAS TÉCNICAS /  
**PT** : CARACTERÍSTICAS TÉCNICAS / **IT** : CARATTERISTICHE TECNICHE / **EL** : ΤΕΧΝΙΚΑ  
ΧΑΡΑΚΤΗΡΙΣΤΙΚΑ / **PL** : CECHY TECHNICZNE / **UA** : ТЕХНІЧНІ ХАРАКТЕРИСТИКИ /  
**RO** : CARACTERISTICI TEHNICE / **BR** : CARACTERÍSTICAS TÉCNICAS / **NL** : TECHNISCHE KENMERKEN  
/ **DE** : TECHNISCHE MERKMALE / **EN** : TECHNICAL SPECIFICATIONS

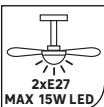
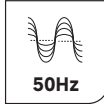

2xE27  
MAX 15W LED

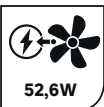

52,6W



55W



6,5

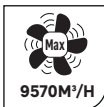

9570M³/H



3,0(m3/min)W



36,5dB(A)



46,8dB(A)



0,2W



2,2M/s



EN IEC60879:2019



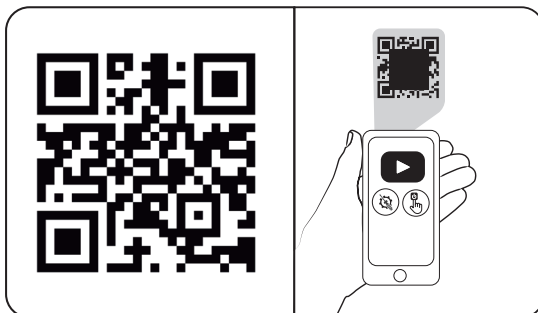

**FR** : Scanner ce code QR pour voir la vidéo de montage

**ES** : Escanear este código QR para ver el video de montaje

**PT** : Digitalize este código QR para ver o vídeo de montagem

**IT** : Scannerizza questo codice QR per vedere il video di montaggio

**EL** : Σαρώστε τον συγκεκριμένο κωδικό QR για να δείτε το βίντεο συναρμολόγησης

**PL** : Zeskanuj ten kod QR, aby zobaczyć wideo montażowe

**UA** : Відскануйте цей QR-код, щоб переглянути відео про монтаж





**RO** : Scanați acest cod QR pentru a viziona videoclipul de montaj

**BR** : Escanear este código QR para ver o vídeo de montagem

**NL** : Scan deze QR-code om de montagevideo te bekijken

**DE** : Scannen Sie diesen QR-Code, um das Montagevideo anzusehen

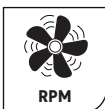
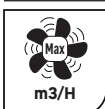
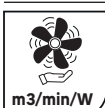
**EN** : Scan this QR code to view the assembly video

	<b>1</b>	<b>2</b>	<b>3</b>
 W	16,6	25,1	52,6
 RPM	97	122	186
 m3/H	4750	6620	9570
 m3/min/W	4,8	4,4	3,0
 XXdB	36,5	38,9	46,8

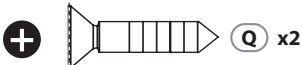
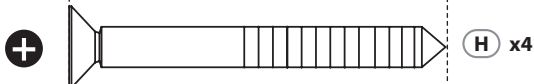
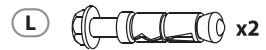
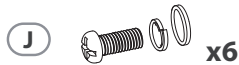
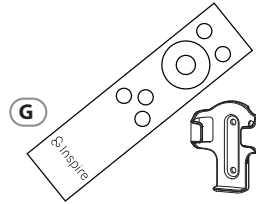
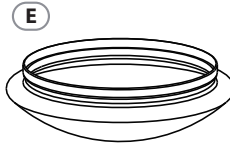
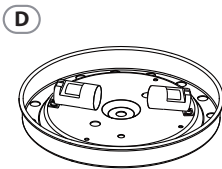
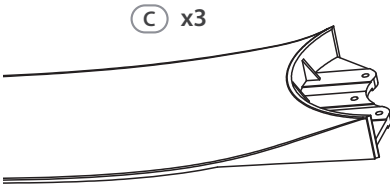
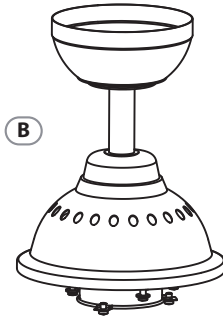
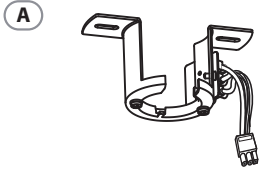



#10

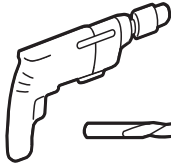

Ø 8



Ø 6

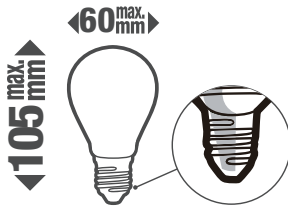
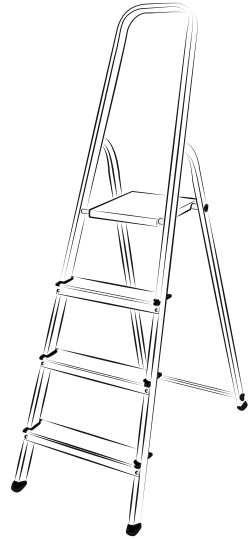

**E27x2**  
**MAX 15W LED**

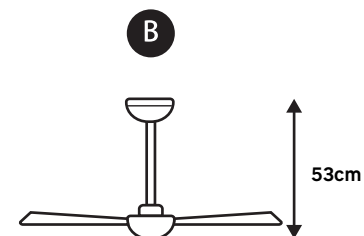
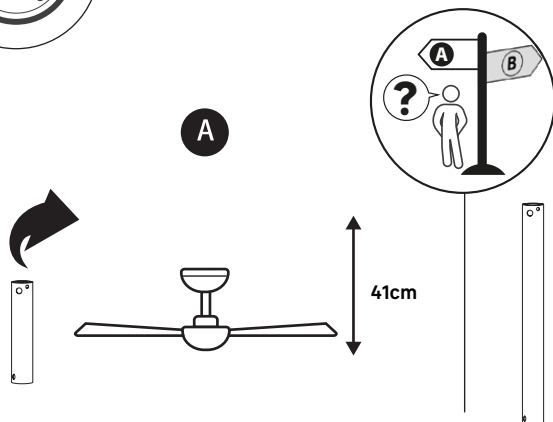
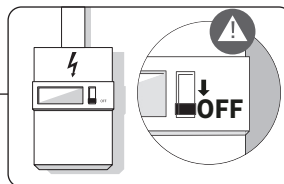

\*FR: voir page 17 / ES: ver pàgina 17 / PT: ver pàgina 17 / IT: vedere pagina 17 / EL: δείτε σελίδα 17 / PL: zobacz stronę 17 / UA: див. стор. 17 / RO: vezi pagina 17 / BR: ver página 17 / NL: zie pagina 17 / DE: siehe Seite 17 / EN: see page 17

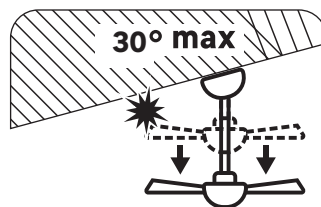
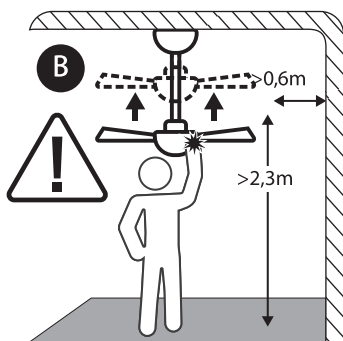
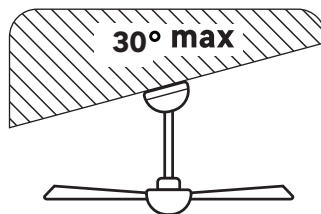
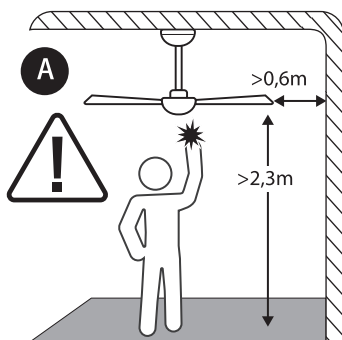



1

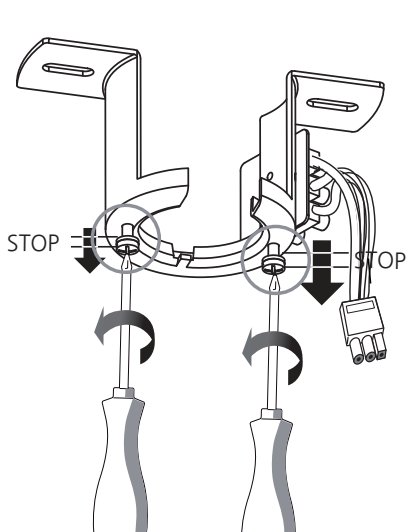
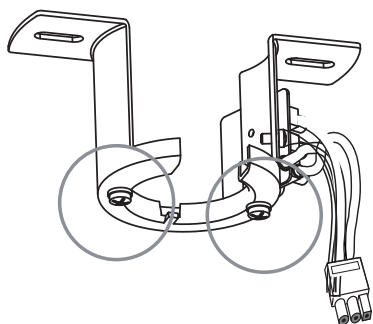

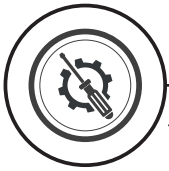

# 2

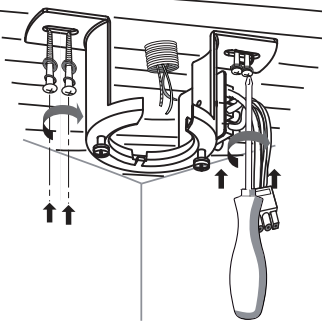

OR

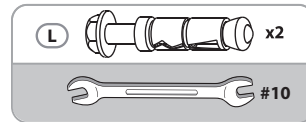
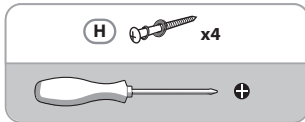
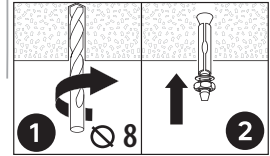
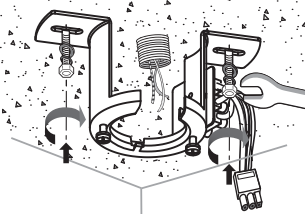

**FR** - fixé avec une résistance suffisante pour résister à 4 fois le poids du ventilateur de plafond / **ES** - fijado con una resistencia suficiente para soportar 4 veces el peso del ventilador de techo / **PT** - fixado com uma resistência suficiente para suportar 4 vezes o peso do ventilador de teto / **IT** - fissato con una resistenza sufficiente per resistere a 4 volte il peso del ventilatore a soffitto / **GR** - στερεωμένο με επαρκή αντοχή για να αντέξει 4 φορές το βάρος του ανεμιστήρα οροφής / **PL** - przymocowany z wystarczającą wytrzymałością, aby wytrzymać 4 razy ciężar wentylatora sufitowego / **UA** - закріплений з достатньою міцністю, щоб витримати 4-кратний вагу стельового вентилятора / **RO** - fixat cu o rezistență suficientă pentru a rezista la 4 ori greutatea ventilatorului de tavan / **BR** - fixado com uma resistência suficiente para suportar 4 vezes o peso do ventilador de teto / **NL** - bevestigd met voldoende sterkte om 4 keer het gewicht van de plafondventilator te weerstaan / **DE** - mit ausreichender Festigkeit befestigt, um 4-mal das Gewicht des Deckenventilators zu tragen / **EN** - fixed with sufficient strength to withstand 4 times the weight of the ceiling fan

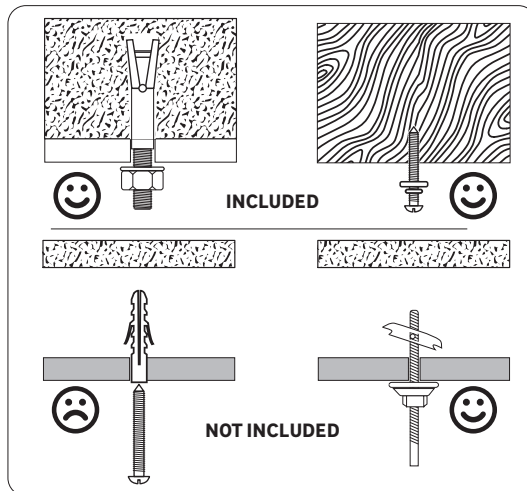
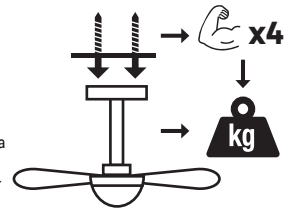

**FR** - Utiliser des vis et des chevilles adaptées à votre support. / **ES** - Utilice tacos y tornillos adecuados al soporte. / **PT** - Utilize buchas e parafusos adequados ao seu suporte. / **IT** - Utilizzare viti e tasselli adatti per il retro. / **GR** - Χρησιμοποιήστε βίδες και βύσματα που ταίριαζουν στην επιφάνεια στήριξης. / **PL** - Należy użyć śrub i kotków odpowiednich dla podłoża. / **UA** - Використовуйте гвинти та шканти, призначені для задньої поверхні. / **RO** - Utilizați șuruburi și dibluri adecvate pentru suportul dvs. / **BR** - Use parafusos e buchas adequados para seu suporte. / **NL** - Gebruik schroeven en pluggen die geschikt zijn voor uw ondergrond. / **DE** - Verwenden Sie für Ihre Unterlage geeignete Schrauben und Dübel. / **EN** - Use screws and dowels suited to your backing.



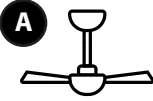
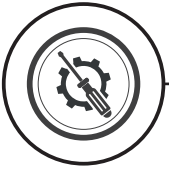

3

B

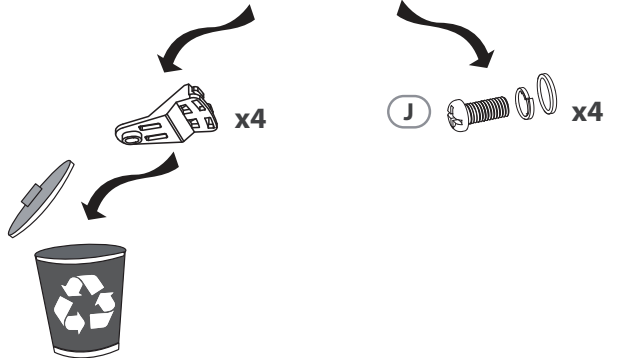
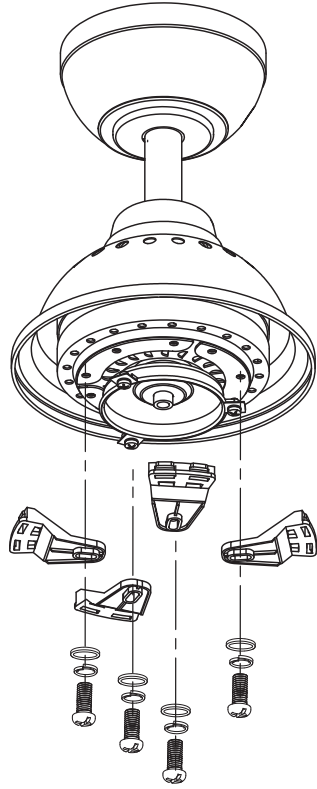
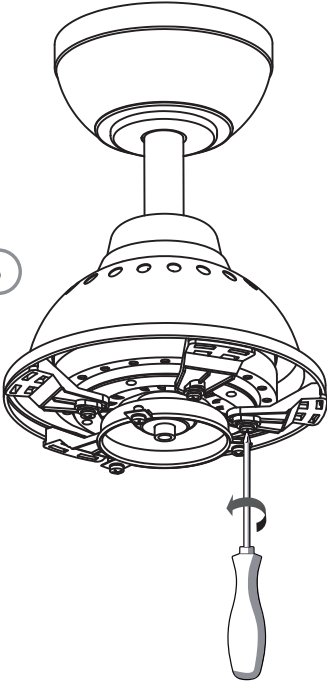

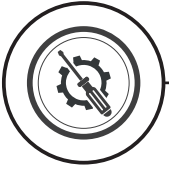

4

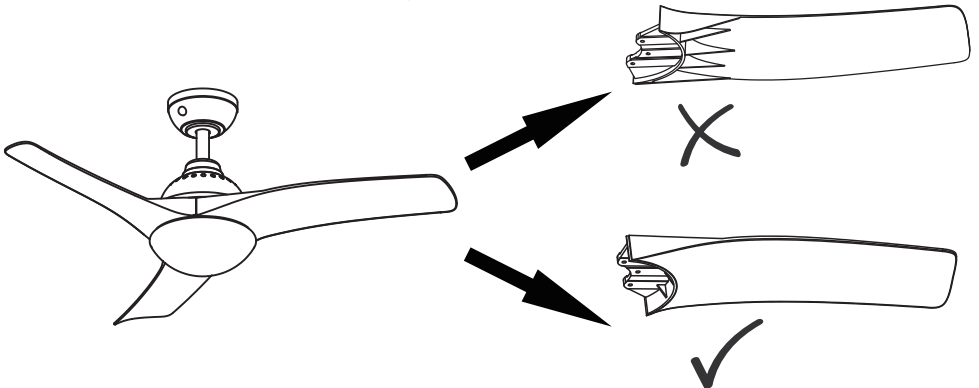
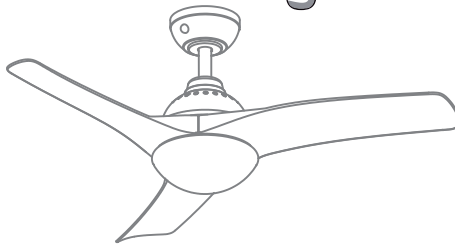
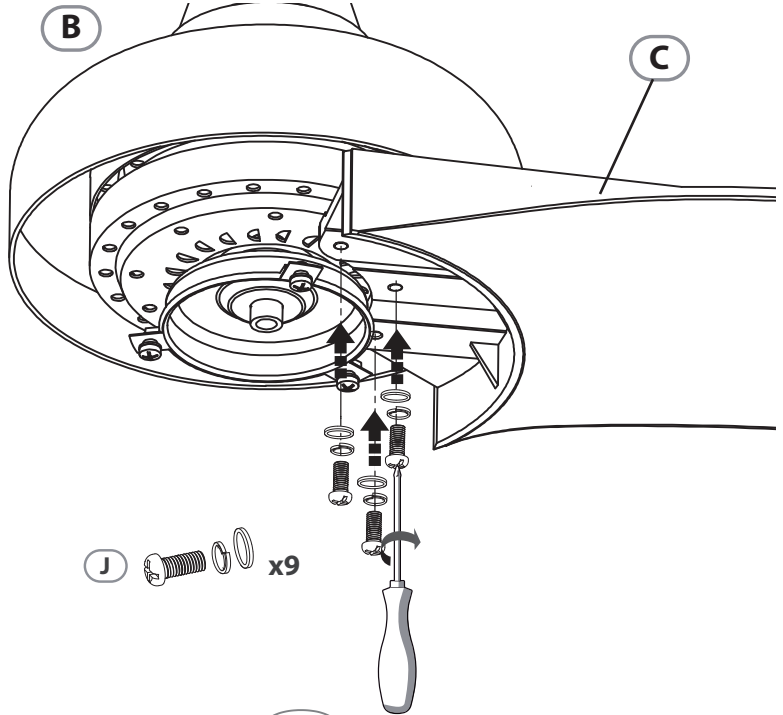



# 5

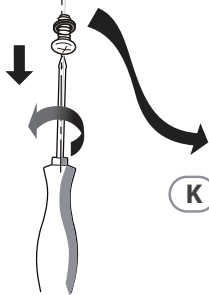
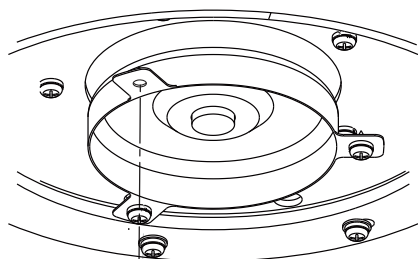
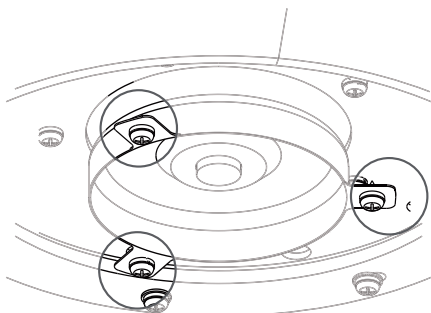

**K**  x3

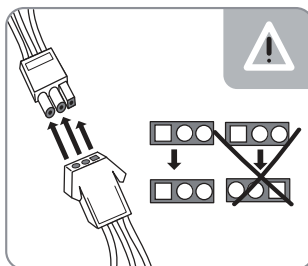
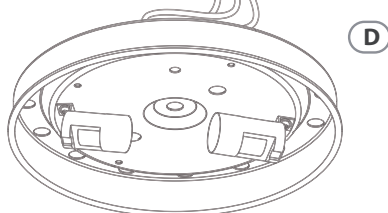
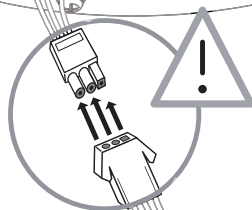
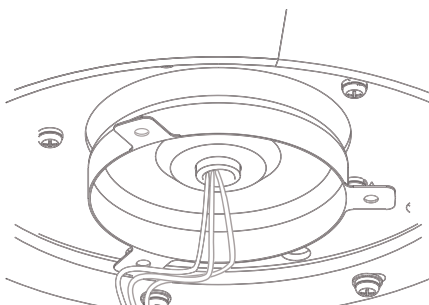



6

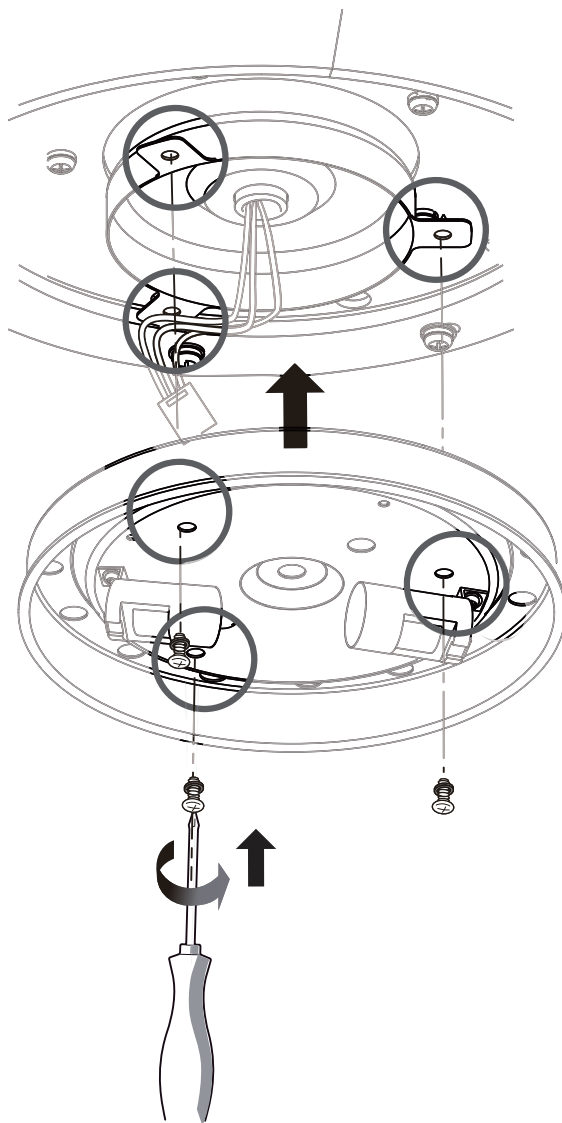

(K)  x3



7

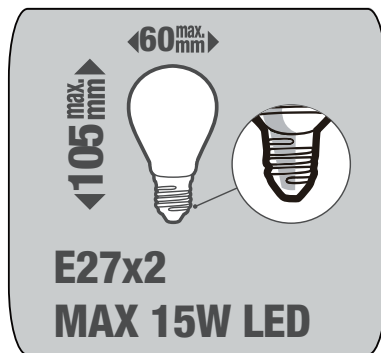
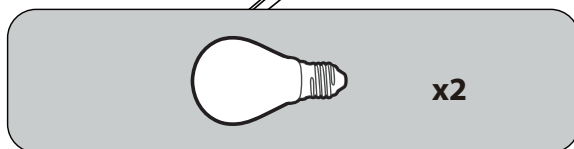
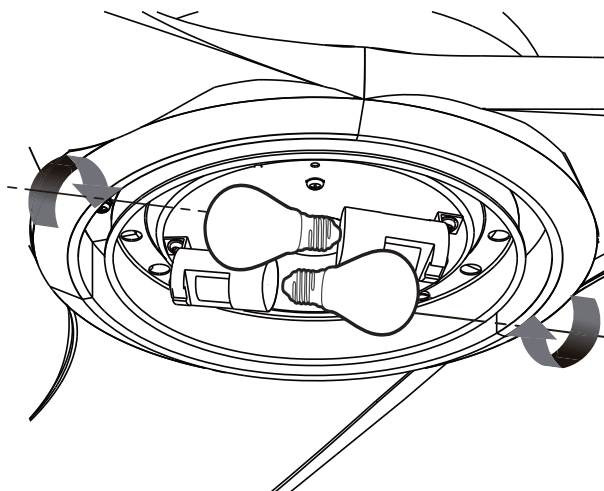

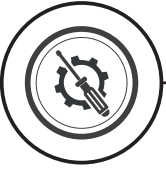

8

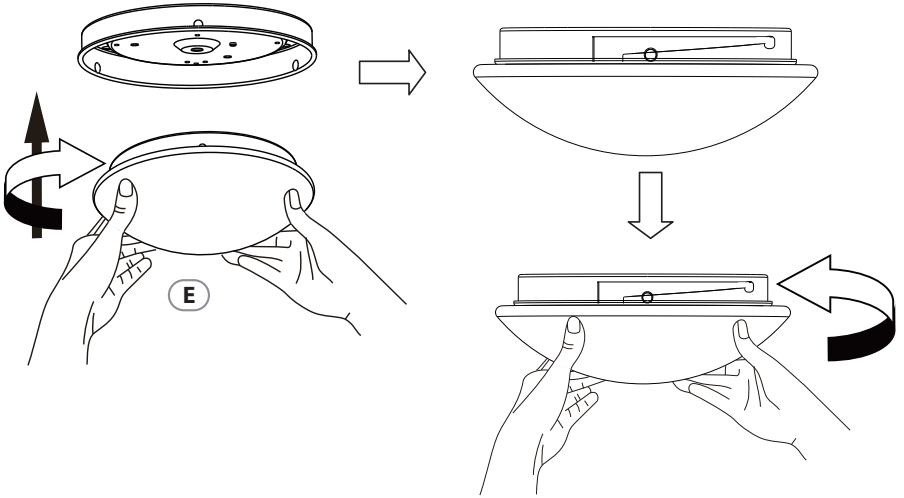

9

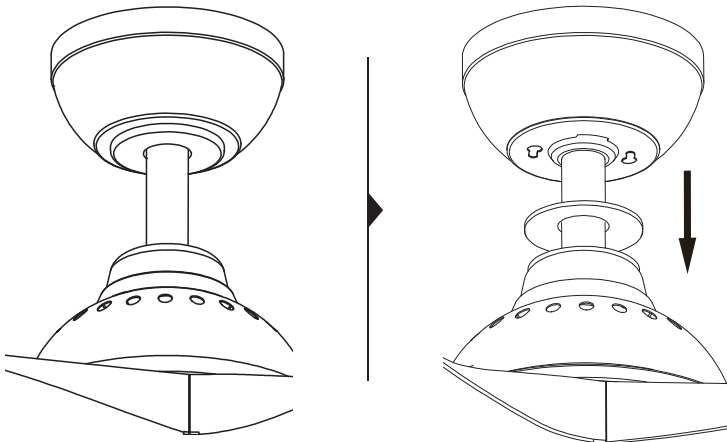



# 10

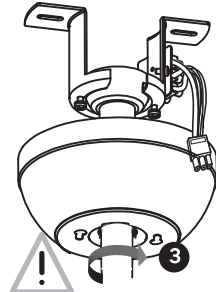
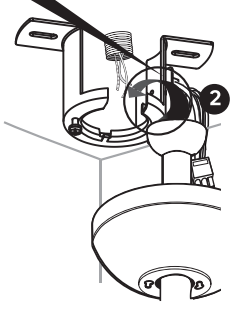
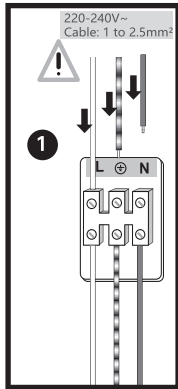

L=Marron/Marrón/Castanho/Marrone/  
Кафе/Бразову/Коричневый/Коңыр/  
Коричневий/Maró/Castanho/Brown

N=Bleu/Azul/Azul/Blu/Μπλε/  
Niebieski/Синий/Кек/  
Синий/Albastru/Azul/Blue

⊕=Vert/Verde/Verde/Verde/  
Πράσινο/Zielony/Зеленый/  
Жасыл/Зеленый/Verde/  
Verde/Green

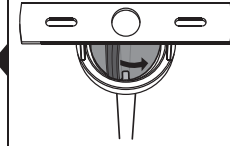
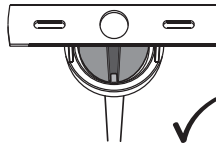

# 11

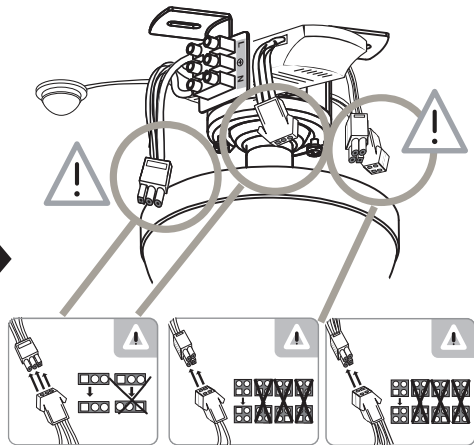
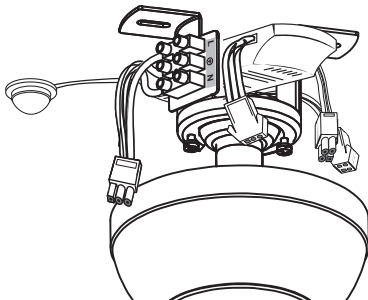
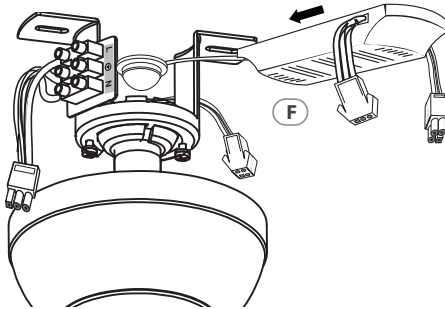

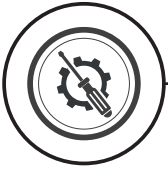

# 12

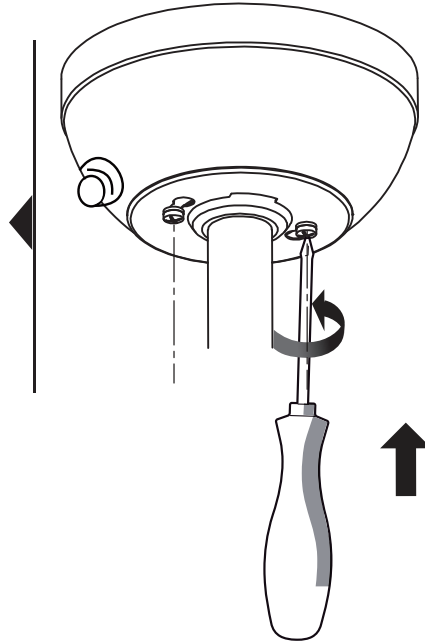
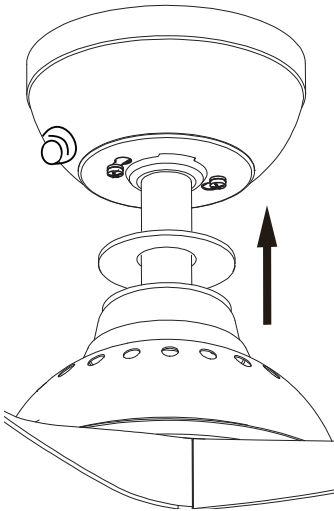
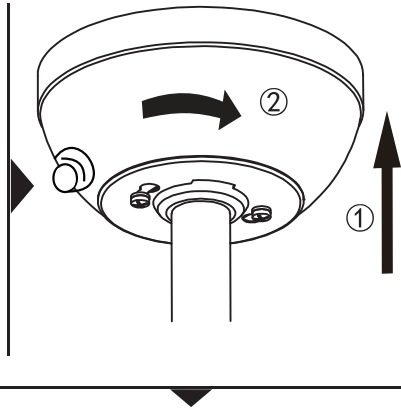
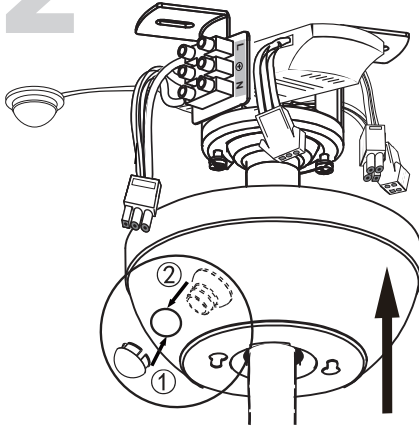



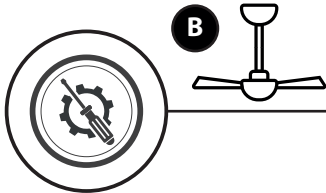

13

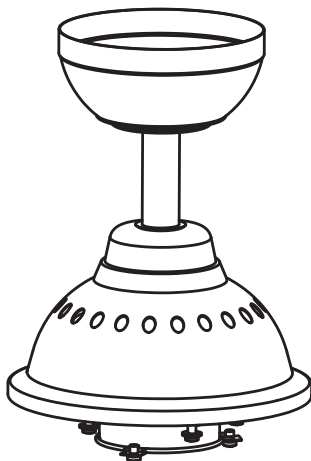

**B**

14

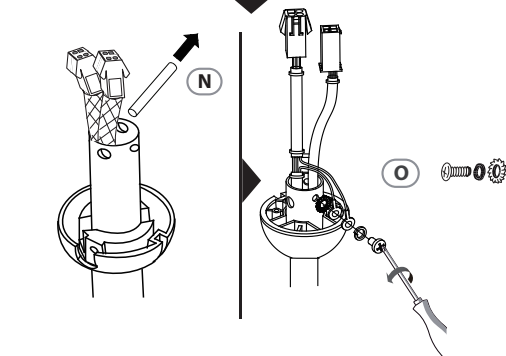
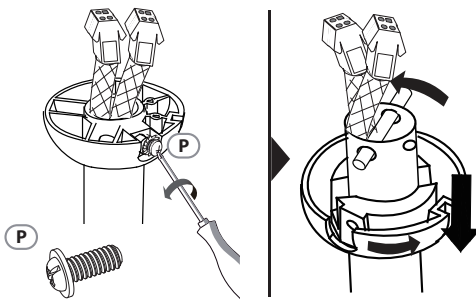
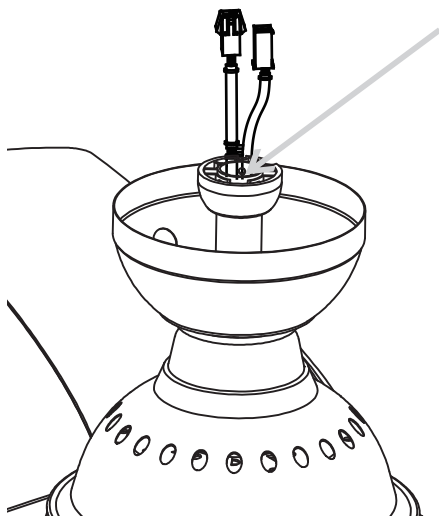



15

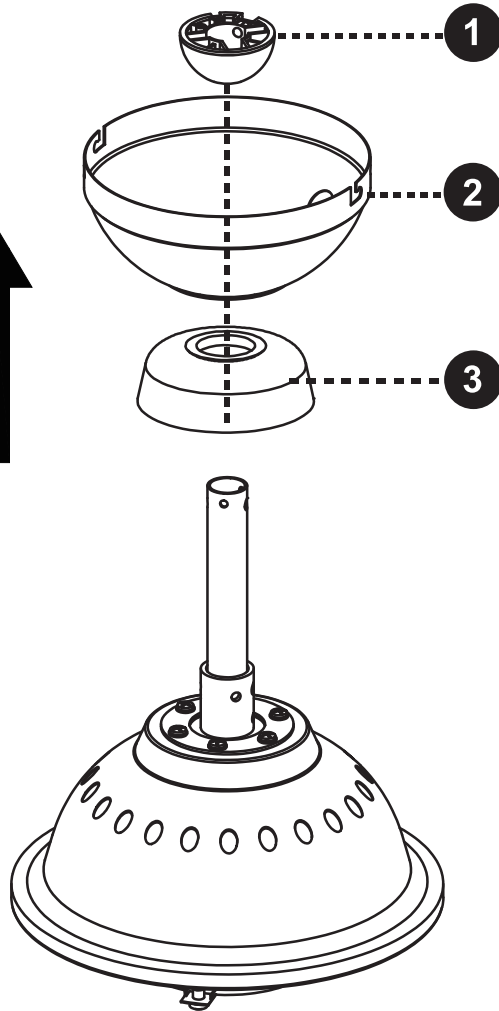



16

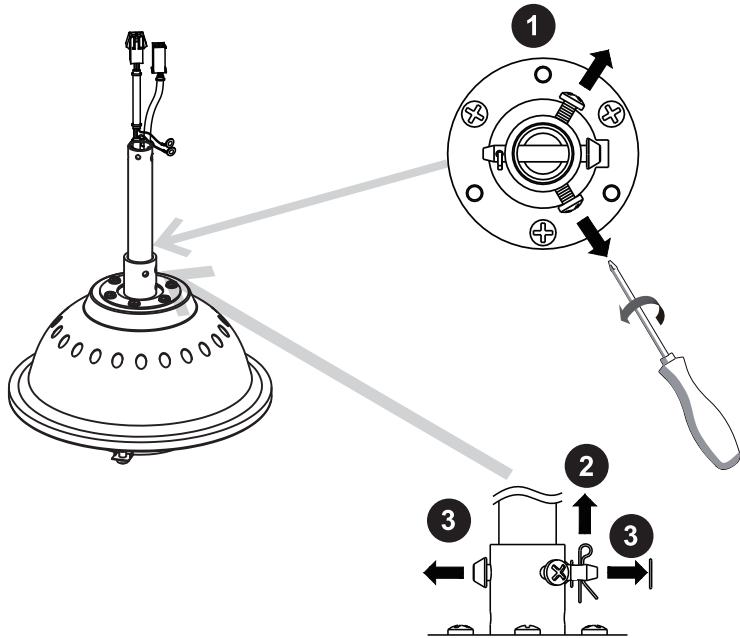

17

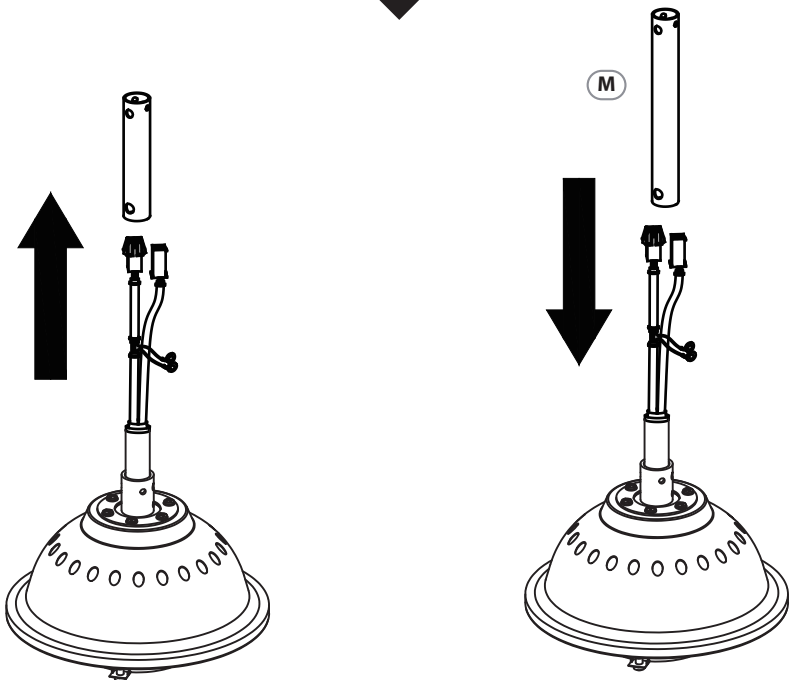



# 18

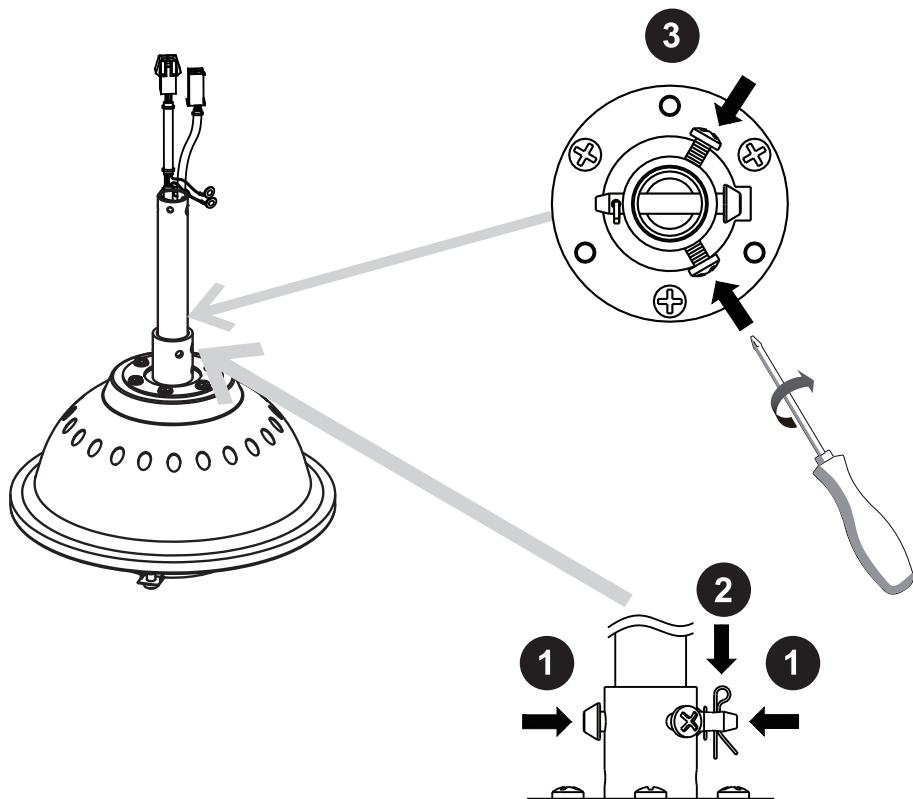



19

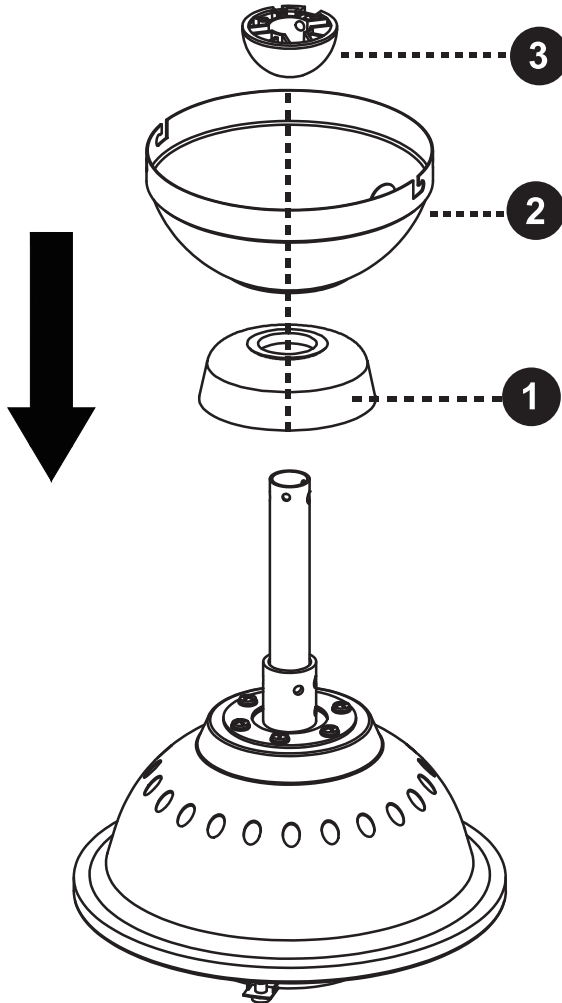



# 20

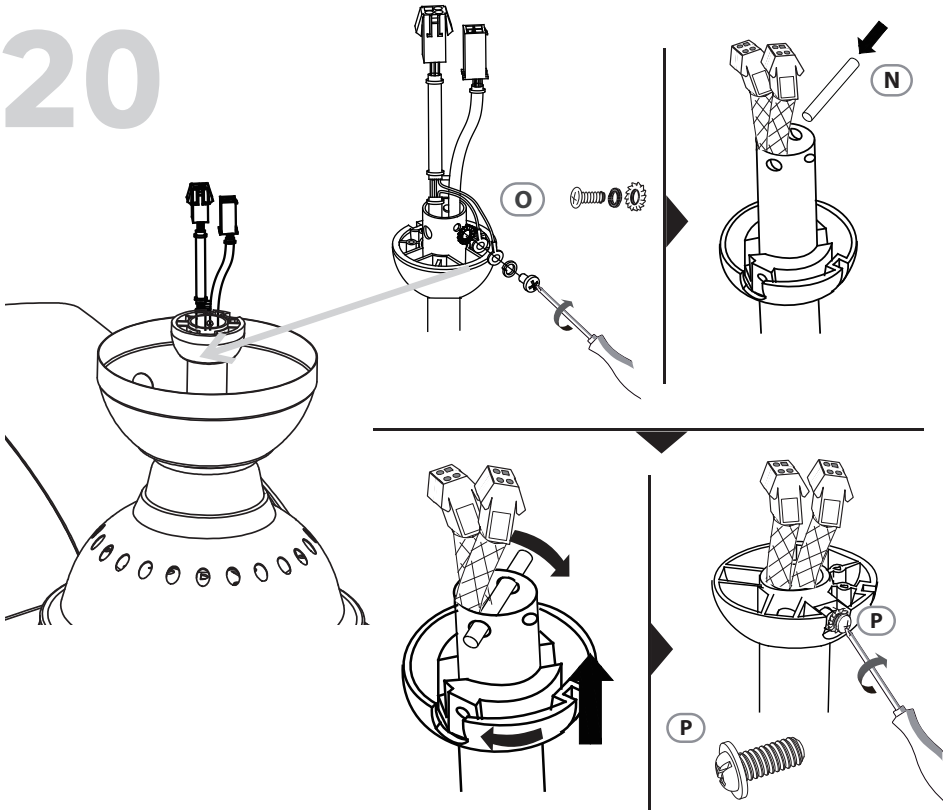

.....

\*FR: voir page 9 - 16, étapes 3 - 12 / ES: ver página 9 - 16, pasos 3 - 12  
PT: ver página 9 - 16, etapas 3 - 12 / IT: vedere pagina 9 - 16, passaggi 3 - 12  
EL: δείτε σελίδα 9 - 16, βήματα 3 - 12 / PL: zobacz stronę 9 - 16, kroki 3 - 12  
UA: див. стор. 9 - 16, кроки 3 - 12 / RO: vezi pagina 9 - 16, pași 3 - 12  
BR: ver página 9 - 16, etapas 3 - 12 / NL: zie pagina 9 - 16, stappen 3 - 12  
DE: siehe Seite 9 - 16, Schritte 3 - 12 / EN: see page 9 - 16, steps 3 - 12



# 21

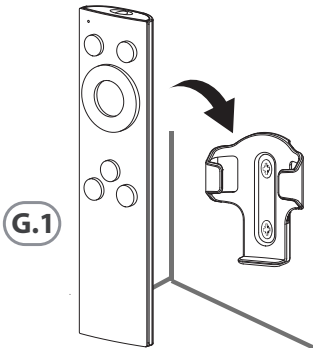
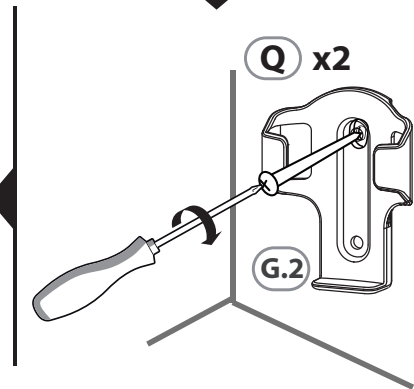
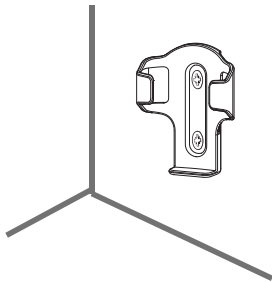
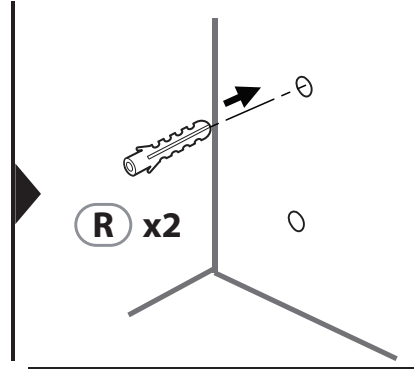
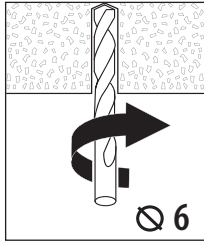



**ON/OFF**

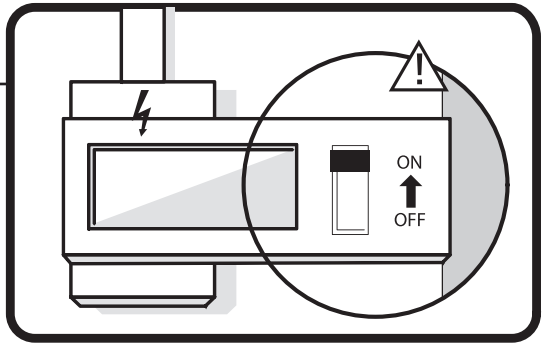
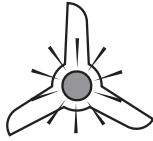

Lumière seulement/Solo luz/Apenas luz/Solo luceΜόνο φως/ Tylko światło/ Тільки світло/Doar lumina/Alleen licht /Nur Licht/**Light only**

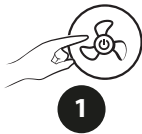

**ON/OFF**

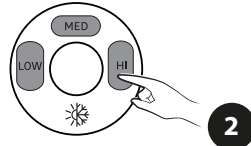

**1 - 2 - 3**



Vitesse/Velocidad/Velocidade/Velocità /Ταχύτητα/Прędkość/Швидкість/Vitezä /Snelheid/Geschwindigkeit/Speed

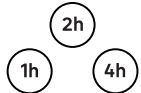
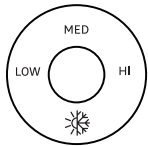

& Inspire

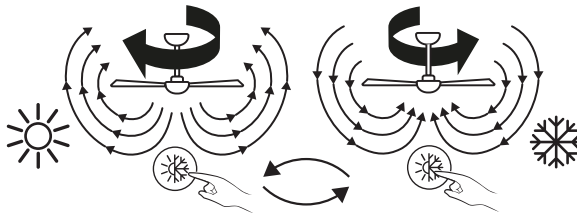

Été/Hiver- Verano/Invierno - Verão/Inverno - Estate/Inverno - Καλοκαίρι/Χειμώνας - Lato/Zima - Літо/Зима - Arã/Iarnã - Zomer/Winter - Sommer/Winter - Summer/Winter

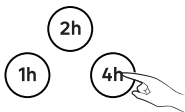

**1h - 2h - 4h ▶ OFF**



Minuterie/Temporizador/ Χρονοδιακόπτης/Minutnik/ Таймер/Cronometru/Timer



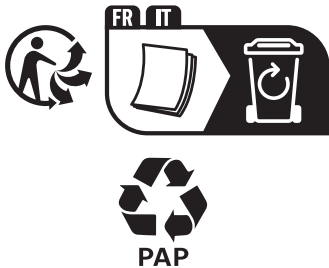

FR Traduction de la version originale du mode d'emploi / ES: Traducción de las Instrucciones originales / PT: Tradução das Instruções Originais / IT: Traduzione delle istruzioni originali / EL: Μετάφραση των πρωτότυπων οδηγιών / PL: Tłumaczenie instrukcji oryginalnej / UA: Переклад оригінальної інструкції / RO: Traducerea instrucțiunilor originale / BR: Tradução das Instruções Originais / DE: Übersetzung der Originalversion der Gebrauchsanweisung / Original Instructions.

Made in China  
Країна походження: Китай

**EU** ADEO Services - 135 Rue Sadi Carnot - CS00001 - 59790 RONCHIN - FRANCE

**UA** Виробник: ТОВ "Адео Сервісез С.А.", вул. Саді Карно, CS 00001, 59790 Роншен, Франція.  
Імпортер: ТОВ "Леруа Мерлен Україна", 04201 Україна, м. Київ, вул. Полярна 17А, +380 44 498 46 00. Імпортер приймає претензії від споживачів щодо товару, а також проводить його ремонт, технічне і гарантійне обслуговування

**ZA** Imported by Adeo South Africa (PTY) LTD T/A Leroy Merlin, Hosted in Leroy Merlin Fourways Store 35 Roos Street, Witkoppen Ext 97, Sandton, 2191 Johannesburg, Gauteng, South Africa.  
Tel: +27 10 493 8000 Email: contact@leroymerlin.co.za.

**BR** LEROY MERLIN COMPANHIA BRASILEIRA DE BRICOLAGEM CNPJ: 01.438.784/0001-05  
Rua Pascoal Pais, nº. 525, 6º andar cj 61 a 64, Vila Cordeiro, São Paulo -SP. CEP: 04581-060  
CALM (Central de Atendimento Leroy Merlin) Capitais  
4020-5376 Demais Regiões 0800-0205376



Points de collecte sur [www.quefairedemesdechets.fr](http://www.quefairedemesdechets.fr)  
Privilégiez la réparation ou le don de votre appareil !