

**delinia**

Guarantee  
**10**  
years

SARA

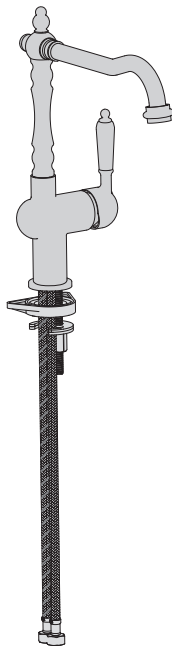

EAN CODE : 3276000592167  
3276000592174  
3276000592181  
3276000596530  
3276000596547  
3276000632450  
3276000632498

**FR** Manuel d'Instructions

**ES** Manual de Instrucciones

**PT** Manual de Instruções

**IT** Manuale di Istruzioni

**EL** Εγχειρίδιο Οδηγιών

**PL** Instrukcja Obsługi

**RU** Руководство по  
Эксплуатации

**KZ** Пайдаланушы Нұсқаулығы

**UA** Інструкція з Експлуатації

**RO** Manual de Instrucțiuni

**BR** Manual de Instruções

**EN** Instructions Manual

2022/05-V03

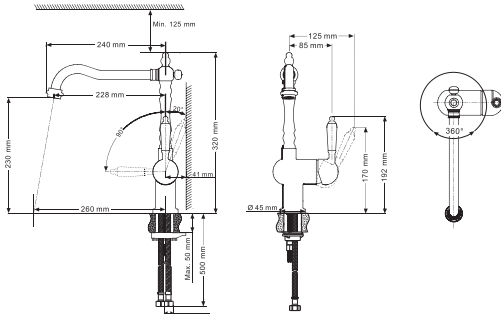

EU: F G 3/8" - 12/17  
RU: F G 1/2" - 19/21  
BR: F G 1/2" - 19/21

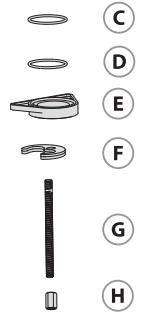
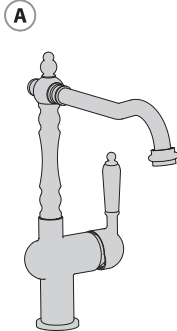



FR: Préparation / ES: Preparación / PT: Preparação / IT: Preparazione / EL: Προετοιμασία /  
PL: Przygotowanie / RU: Подготовка / KZ: Дайындау / UA: Підготування / RO: Pregătire / BR: Preparação /  
EN: Preparation



FR: Montage / ES: Montaje / PT: Montagem / IT: Montaggio / EL: Συνμολόγηση /  
PL: Montaż / RU: Сборка / KZ: Монтаждау / RO: Montaj / BR: Montagem /  
EN: Assembly



FR: Utilisation eau chaude-eau froide/ ES: Utilización agua caliente-agua fría/ PT: Utilização água quente-água fria/  
IT: Uso acqua calda-acqua fredda/ EL: Χρήση ζεστού-κρύου νερού/ PL: Użytkowanie zimnej wody-gorącej wody/  
RU: Использование горячей и холодной воды/ UA: використання гарячої - холодної води/  
RO: Utilizare apă caldă-apă rece/ EN: Using hot and cold water



FR: Changement de cartouche/ ES: Cambio de cartucho/ IT: Cambio cartuccia/ PT: Mudança de cartucho/  
EL: Αλλαγή φουγγιγίου/ PL: Wymiana wkładu / RU: Смена картриджа/ KZ: Картриджді ауыстыру/  
UA: заміна картриджа/ RO: Schimbare cartuş/ BR: Substituição de cartucho/ EN: Replacing the cartridge



FR: Changement de moussEUR/ ES: Cambio de aireador/ PT: Mudança de arejador/ IT: Cambio rompigogetto/  
EL: Αλλαγή αεράτορα / PL: Wymiana perlatora / RU: Смена азратора/ KZ: Ауақанықтырғышты ауыстыру/  
UA: заміна аератора/ RO: Schimbare aerator/ BR: Substituição do aerador/ EN: Replacing the aerator



FR: Changement de flexibles/ ES: Cambio de flexibles / PT: Mudança de flexíveis/ IT: Cambio flessibili/  
EL: Αλλαγή λάστιχων/ PL: Wymiana wężyków instalacyjnych / RU: Смена гибкого шланга для смесителя/  
UA: заміна гнучкого шланга для змішувача/ KZ: Қоспалауышқа арналған иілгіш шлангты ауыстыру/  
RO: Schimbare furtune flexibile/ BR: Substituição das mangueiras/ EN: Replacing the hoses

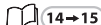



FR: Préparation / ES: Preparación / PT: Preparação / IT: Preparazione / EL: Προετοιμασία /  
PL: Przygotowanie / RU: Подготовка / KZ: Дайындау / UA: Підготовка / RO: Pregătire /  
BR: Preparação / EN: Preparation

1

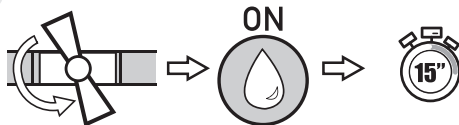

2

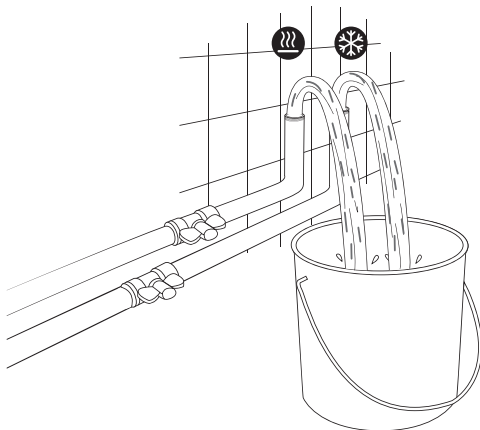

3

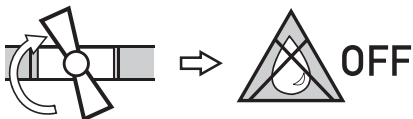



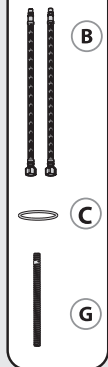

PH2



FR: Montage / ES: Montaje / PT: Montagem / IT: Montaggio / EL: Συναρμολόγηση /  
PL: Montaż / RU: Сборка / KZ: Монтаж / UA: Збірка / RO: Montaj / BR: Montagem /  
EN: Assembly

1

1

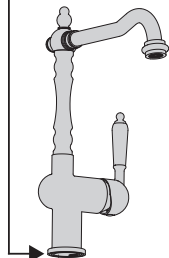
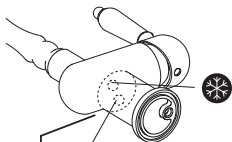

B

2

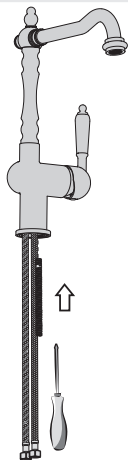

G

3

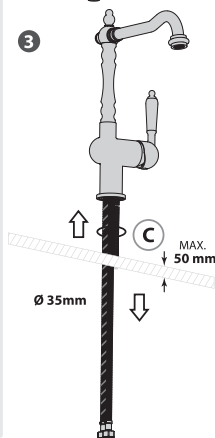



2

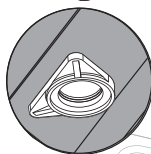
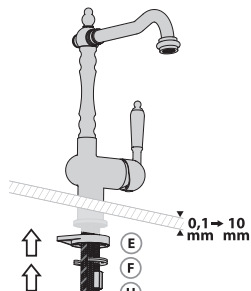
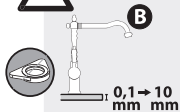
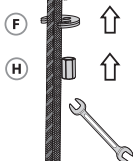
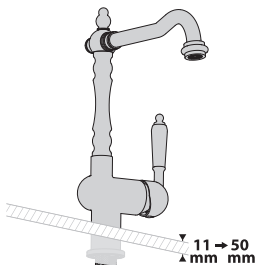
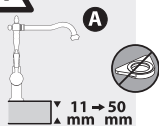

E

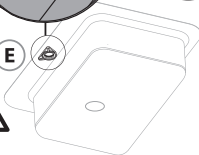

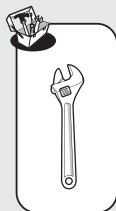

3

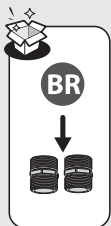
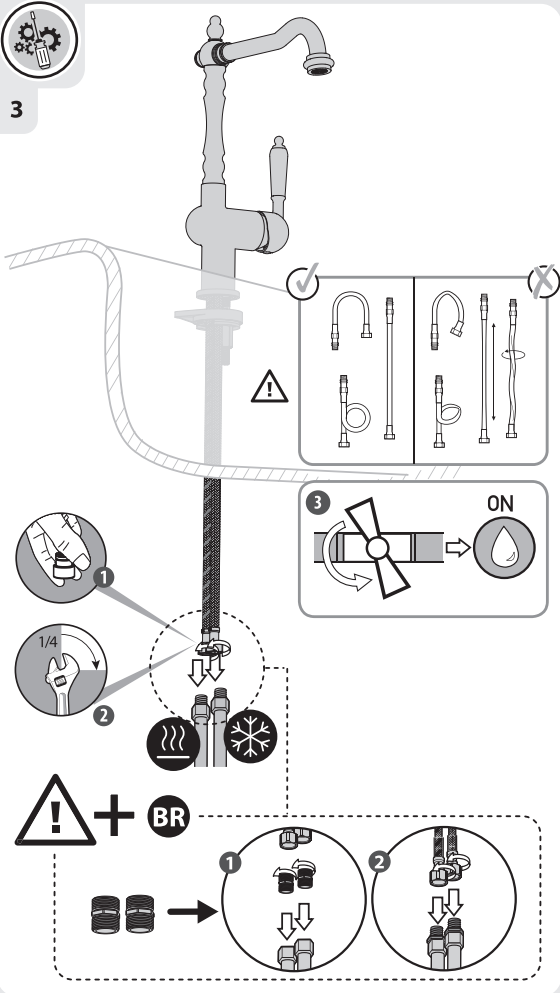



FR: Utilisation eau chaude-eau froide/ ES: Utilización agua caliente-agua fría/ PT: Utilização água quente-água fria/  
IT: Uso acqua calda-acqua fredda/ EL: Χρήση ζεστού-κρύου νερού/ PL: Użytkowanie zimnej wody-gorącej wody/  
RU: Использование горячей и холодной воды/ KZ: Суық және ыстық суды қолдану/  
UA: використання гарьчої - холодної води/ RO: Utilizare apă caldă-apă rece/ BR: Uso de água quente e fria/  
EN: Using hot and cold water

1

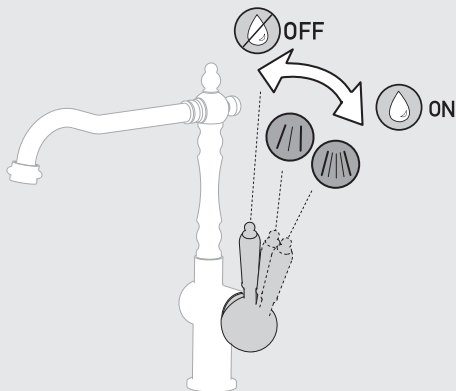
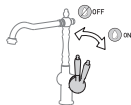

2

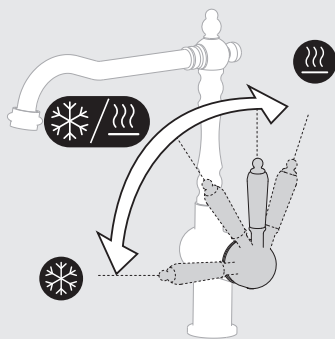

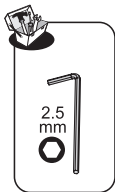

FR: Changement de cartouche/ ES: Cambio de cartucho/ IT: Cambio cartuccia/ PT: Mudança de cartucho/  
EL: Αλλαγή φουσιγγίου/ PL: Wymiana wkładu / RU: Смена картриджа/ KZ: Картриджи ауыстыру/  
UA: Заміна картриджа/ RO: Schimbare cartus/ BR: Substituição de cartucho/ EN: Replacing the cartridge

1



OFF

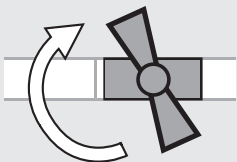

2

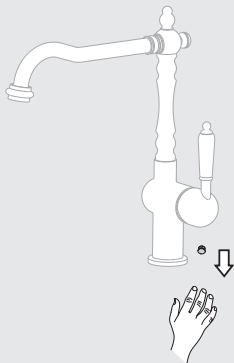

3

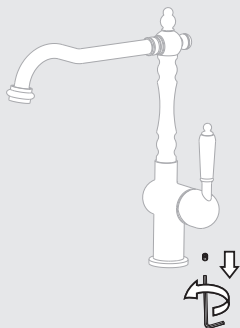

4

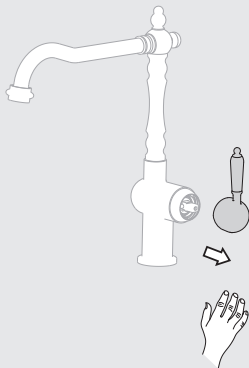

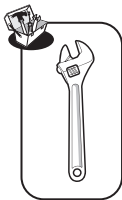

FR: Changement de cartouche/ ES: Cambio de cartucho/ IT: Cambio cartuccia/ PT: Mudança de cartucho/  
EL: Αλλαγή φαισγγίου/ PL: Wymiana wkładu / RU: Смена картриджа/ KZ: Картриджді аумстыру/  
UA: Заміна картриджа/ RO: Schimbare cartus/ BR: Substituição de cartucho/ EN: Replacing the cartridge

5

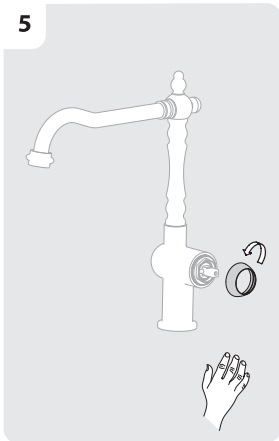

6

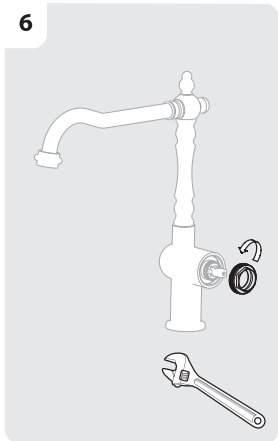

7



8

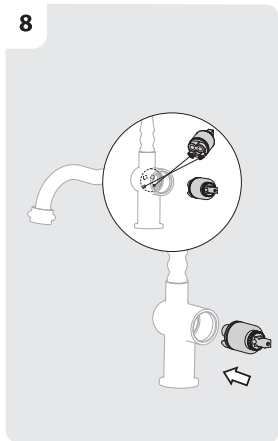

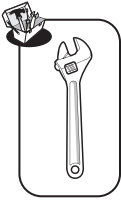

FR: Changement de cartouche/ ES: Cambio de cartucho/ IT: Cambio cartuccia/ PT: Mudança de cartucho/  
EL: Αλλαγή φιογγίου/ PL: Wymiana wkładu/ RU: Смена картриджа/ KZ: Картриджи ауыстыру/  
UA: Заміна картриджа/ RO: Schimbare cartuş/ BR: Substituição de cartucho/ EN: Replacing the cartridge

9

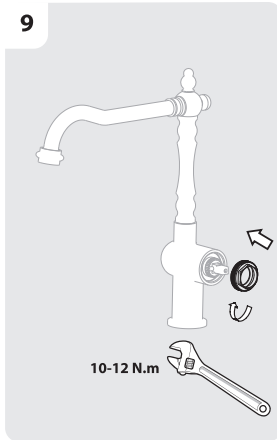

10-12 N.m

10

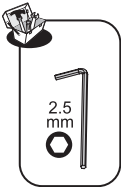
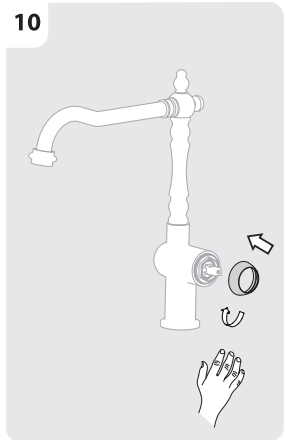

2.5  
mm

11



12

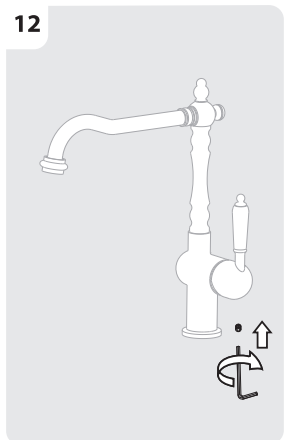



FR: Changement de cartouche/ ES: Cambio de cartucho/ IT: Cambio cartuccia/ PT: Mudança de cartucho/  
EL: Αλλαγή φιογγίου/ PL: Wymiana wkładu / RU: Смена картриджа/ KZ: Картриджи ауыстыру/  
UA: Заміна картриджа/ RO: Schimbare cartus/ BR: Substituição de cartucho/ EN: Replacing the cartridge

13

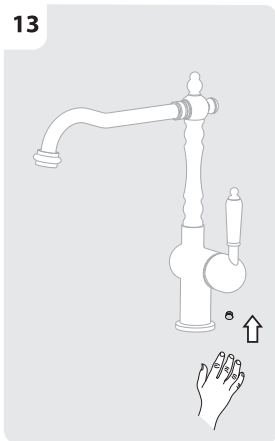

14

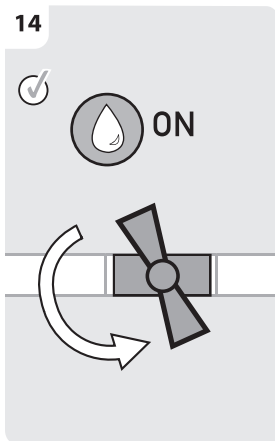



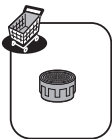

FR: Changement de mousseur/ ES: Cambio de aireador/ PT: Mudança de arejador/ IT: Cambio rompigetto/  
 EL: Αλλαγή αεράτορα / PL: Wymiana perlatora / RU: Смена аэратора/ KZ: Ауақанықтырғышты ауыстыру/  
 UA: Заміна аератора/ RO: Schimbare aerator/ BR: Substituição do aerador/ EN: Replacing the aerator

1

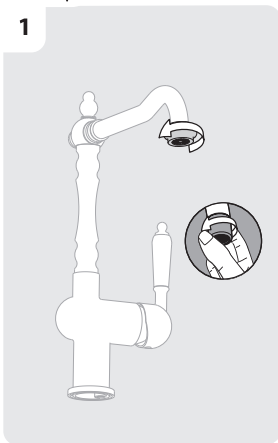

2

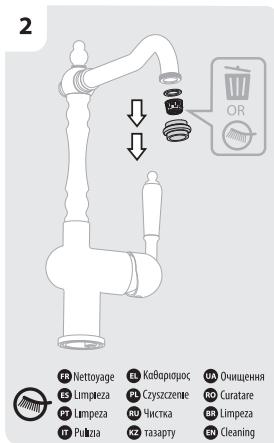

- |              |             |              |             |              |                |              |             |
|--------------|-------------|--------------|-------------|--------------|----------------|--------------|-------------|
| FR Nettoyage | ES Limpieza | PT Limpeza   | IT Pulizia  | EL Καθαρμός  | PL Czyszczenie | RU Чистка    | UA Очищення |
| ES Limpieza  | PL Limpeza  | RU Чистка    | UA Очищення | FR Nettoyage | IT Pulizia     | EL Καθαρμός  | RO Curățare |
| PT Limpeza   | RU Чистка   | UA Очищення  | RO Curățare | ES Limpieza  | EL Καθαρμός    | FR Nettoyage | BR Limpeza  |
| IT Pulizia   | EL Καθαρμός | FR Nettoyage | BR Limpeza  | PT Limpeza   | RU Чистка      | UA Очищення  | EN Cleaning |

3

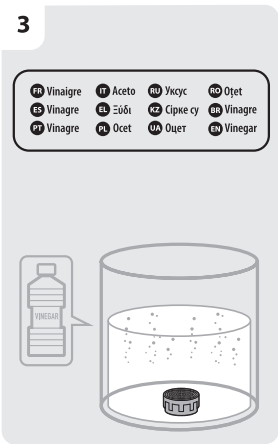

- |              |          |             |            |
|--------------|----------|-------------|------------|
| FR Vinaigre  | IT Aceto | RU Уксус    | RO Oțet    |
| ES Vinagre   | EL Ξίδι  | KZ Сірке су | BR Vinagre |
| PL Winograce | PL Ocet  | UA Оцет     | EN Vinegar |

4

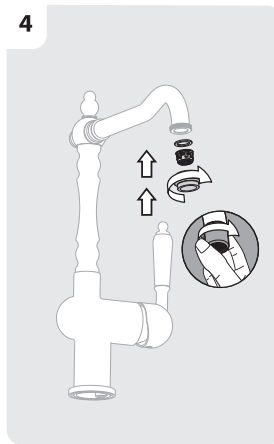

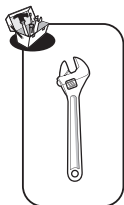

FR: Changement de flexibles/ ES: Cambio de flexibles / PT: Mudança de flexíveis/ IT: Cambio flessibili/  
EL: Αλλαγή λάστιχων/ PL: Wymiana wężyków instalacyjnych / RU: Смена гибкого шланга для смесителя/  
UA: Заміна гнучкого шланга для змішувача/ KZ: Қоспауышқа арналған иілгіш шлангты ауыстыру/  
RO: Schimbare furtune flexibile/ BR: Substituição das mangueiras/ EN: Replacing the hoses

1

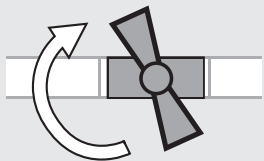

2

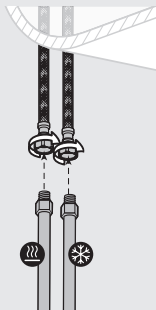

3



ON

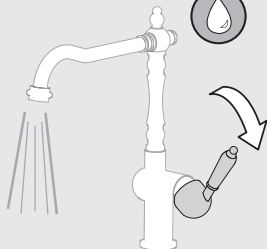

4

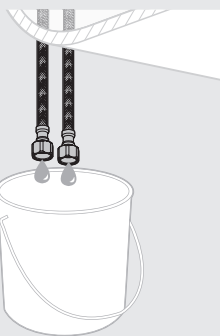



FR: Changement de flexibles/ ES: Cambio de flexibles / PT: Mudança de flexíveis/ IT: Cambio flessibili/  
EL: Αλλαγή λάστιχων/ PL: Wymiana wężyków instalacyjnych / RU: Смена гибкого шланга для смесителя/  
UA: Заміна гнучкого шланга для змішувача/ KZ: Қоспалауышқа арналған иілгіш шлангты ауыстыру/  
RO: Schimbare furtune flexibile/ BR: Substituição das mangueiras/ EN: Replacing the hoses

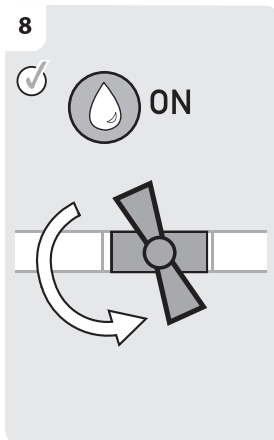
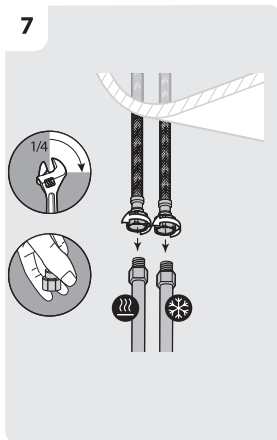
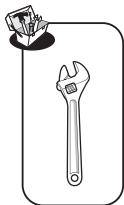
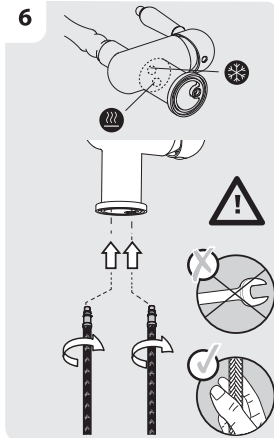
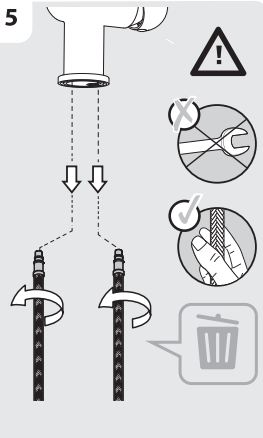



Eau claire / Agua limpia / Água limpa / Acqua pulita / Καθαρό νερό / Czysta woda / Чистая вода / Água limpa /  
Чиста вода / Apa curata / таза су / Clean water



Sans solvant / Sin disolvente / Sem solventes / Senza solventi / Χωρίς διαλυτικά / Bez rozpuszczalnika / Без растворителя /  
Sem solventes / Без розчинника / Fara solvent / еріткучіс / Solvent-free

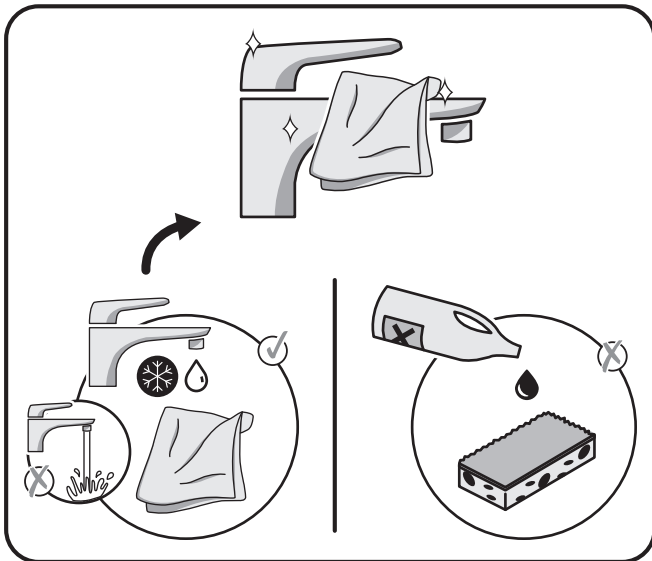

NO	DESCRIPTION	CODE NO	QTY	REMARK
1	Handle	92222CR	1	barcode:3276000592167 / 3276000596530 / 3276000632450
		92222BB		barcode:3276000592174 / 3276000632498
		92222MB		barcode:3276000592181 / 3276000596547
2	Beauty Cover	6030B7 CR	1	barcode:3276000592167 / 3276000596530 / 3276000632450
		6030B0 BB		barcode:3276000592174 / 3276000632498
		6030B0 MB		barcode:3276000592181 / 3276000596547
3	Pressing Nut	604119 BC	1	
4	Cartridge	EC40 CD COLD DUE MIRROR	1	
5	Mixer Body	109120 CR	1	3276000592167 / 3276000596530 / 3276000632450
		109120 BB		3276000592174 / 3276000632498
		109120 MB		3276000592181 / 3276000596547
6	Spout	92201CR	1	3276000592167 / 3276000596530 / 3276000632450
		92201BB		3276000592174 / 3276000632498
		92201MB		3276000592181 / 3276000596547
7	Aerator	403004.000	1	
8	Aerator Shell	301020 CR	1	3276000592167 / 3276000596530 / 3276000632450
		301020 BB		3276000592174 / 3276000632498
		301020 MB		3276000592181 / 3276000596547
9	O ring	126	1	
10	Triangle base	47003.001BC	1	
11	Fixing pack	47004.001BC	1	
12	Inlet hose	TA62-PEX-CN6-AC.B H3-8-MBX1 L1.3-350	2	3276000592167 / 3276000592174 / 3276000592181
13	Connector	TA62-PEX-CN6-AC.B H1.2-MBX1 L1.3-350	2	3276000596530 / 3276000632450 / 3276000632498 / 3276000596547

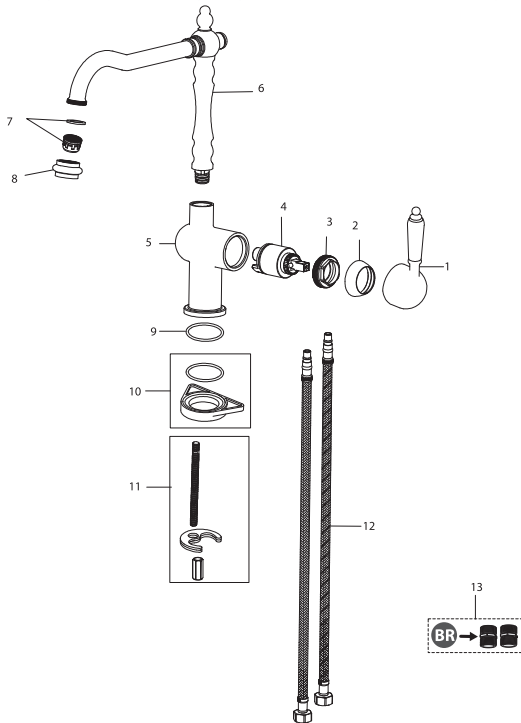

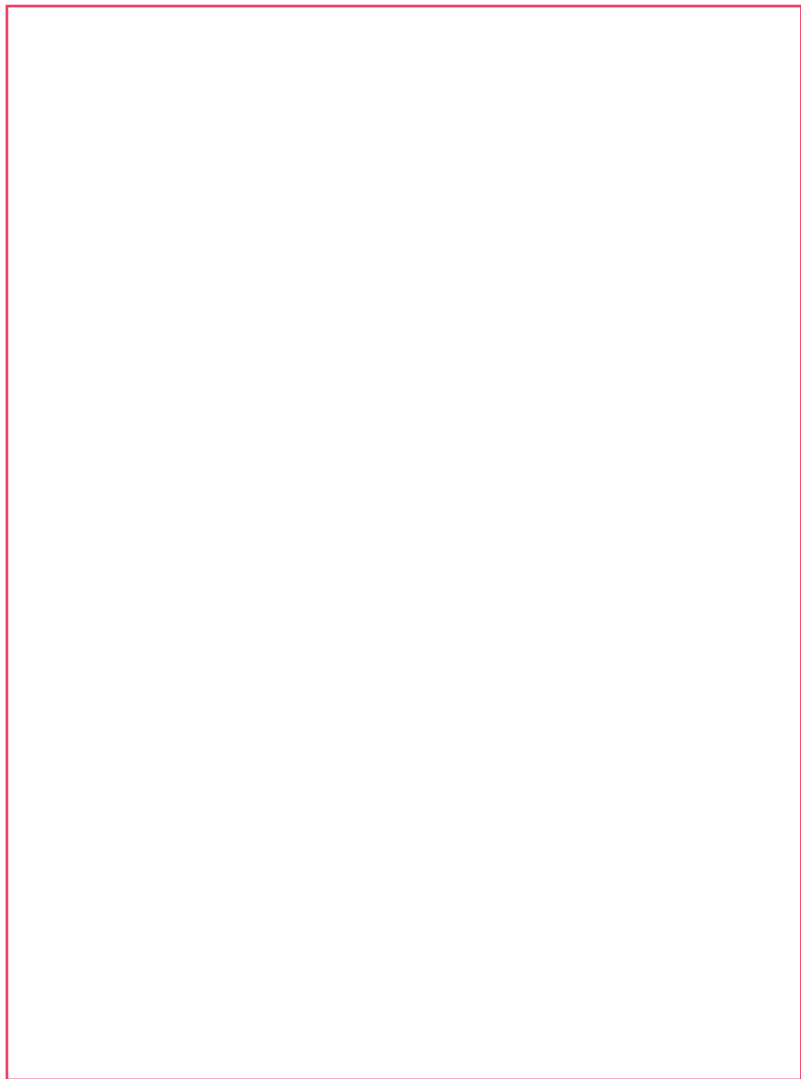

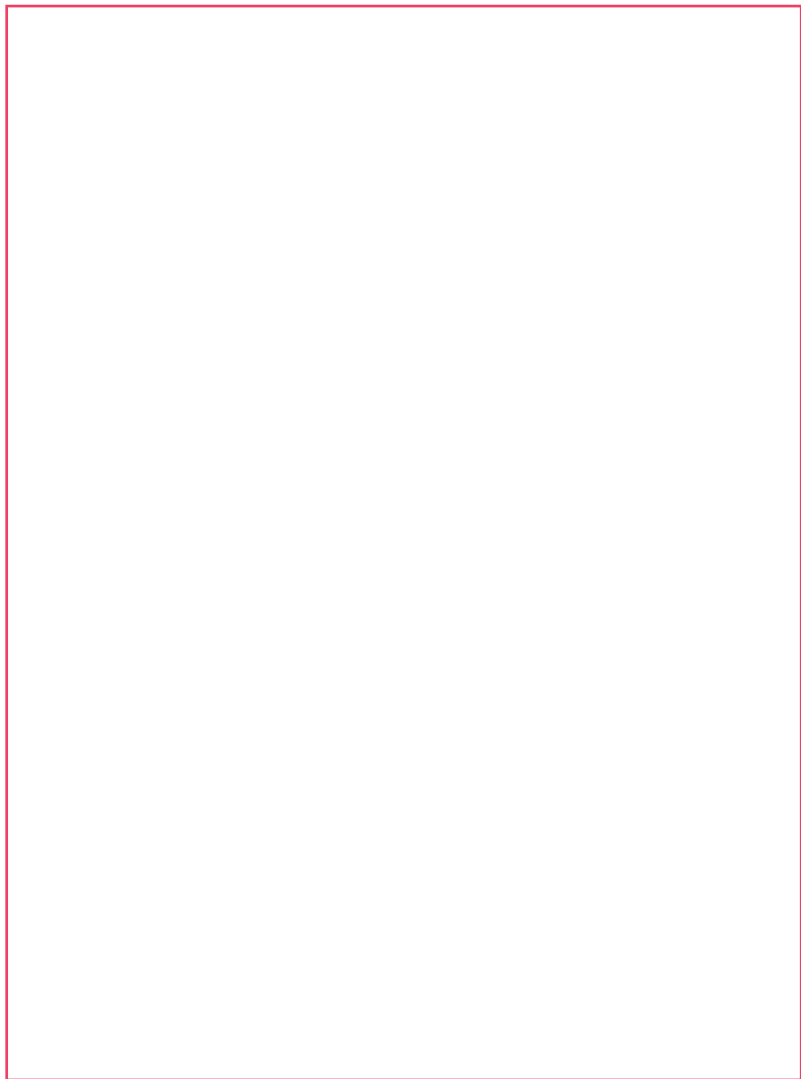



Certificado de conformidad sanitaria.  
Atestado de conformidade sanitária.  
certificato di conformità sanitaria.  
Βεβαίωση υγειονομικής συμμόρφωσης.  
Certyfikat zgodności sanitarnej.  
Декларация о соответствии санитарным нормам  
Санитарлық талаптарға сәйкестік декларациясы  
Декларация про відповідність санітарним нормам  
Atestat de conformitate sanitară  
Certificado de conformidade sanitária.  
Declaration of sanitary conformity.  
Attestation de conformité sanitaire

\* Garantie 10 ans / 10 años de garantía / Garantia de 10 anos / Garanzia 10 Anni / Εγγύηση 10 ετών / Gwarancja 10-letnia / Гарантія 10 років / Кенісшілік 10 жыл / Гарантія 10 років /  
Garantie 10 ani / 10 años de garantía / 10-year guarantee

ADEO Services - 135 Rue Sadi Carnot - CS 00001  
59790 RONCHIN - France



ТОВ «Леруа Мерлен Україна»,  
вул. Полярна 17а, м. Київ 04201, Україна

Made in P.R.C 2018







**OK**

**TASK FORCE GREEN  
DOT / SORTING  
INSTRUCTION  
2021**