

- FR** : La présence sur ce robinet d'un ou plusieurs clapet(s) anti-retour est nécessaire au bon fonctionnement de l'ensemble de votre installation en eau. Ne tentez pas de le(s) retirer.
- ES** : La presencia en este grifo de una o de varias válvula(s) de retención es necesaria para el buen funcionamiento del conjunto de su instalación de agua. No intente retirarla(s).
- PT** : A presença nesta torneira de uma ou mais válvula(s) de retenção é necessária para o funcionamento adequado de toda a instalação de água. Não tente removê-la(s).
- IT** : La presenza su questo rubinetto di una o più valvole anti riflusso è necessaria per il buon funzionamento della totalità del vostro impianto in acqua. Non tentate di rimuoverle.
- PL** : Obecność jednego lub więcej zaworów zwrotnych kranu jest niezbędna dla prawidłowego funkcjonowania całej instalacji wodnej. Nie należy ich usuwać.
- EL** : Η παρουσία σε αυτήν την μπαταρία, μίας ή περισσότερών, βαλβίδων αντεπιστροφής είναι απαραίτητη για την καλή λειτουργία του συνόλου της υδραυλικής σας εγκατάστασης. Μην επιχειρήσετε να τις αποσπάσετε.
- UA** : Наявність на цьому крані одного або декількох зворотних клапанів необхідна для правильної роботи всієї водопровідної установки. Не намагайтеся його/їх знімати.
- RO** : Prezența pe această robinet a uneia sau mai multor supape de reținere este necesară pentru buna funcționare a întregii dvs. instalații de apă. Nu încercați să le eliminați.
- EN** : The presence of one or more anti-return valve(s) on this tap is required for proper operation of your water setup. Please do not attempt to remove it/them.



Attestation de conformité sanitaire  
 Certificado de conformidad sanitaria.  
 Atestado de conformidade sanitária.  
 certificato di conformità sanitaria.  
 Βεβαίωση υγειονομικής συμμόρφωσης.  
 Certyfikat zgodności sanitarnej.  
 Декларация про відповідність санітарним нормам  
 Atestat de conformitate sanitară  
 Declaration of sanitary conformity.



\* Garantie 2 ans / Garantía 2 años / Garantia 2 anos / Garanzia 2 anni / Εγγύηση 2 ετών /  
 Gwarancja 2 lat / Гарантія 2 років / Garantie 2 ani / Guarantee 2 years

Made in P.R.C

ADEO Services - 135 Rue Sadi Carnot - CS 00001  
 59790 RONCHIN - France

**UA** ТОВ «Леруа Мерлен Україна»,  
 вул. Полярна 17а, м. Київ 04201, Україна

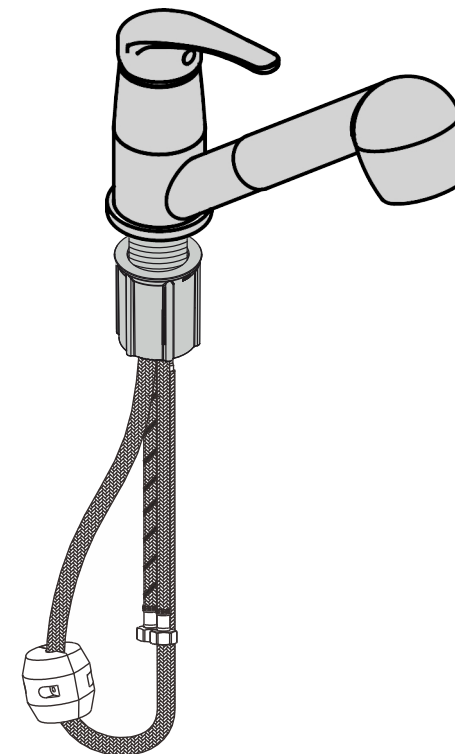

EAN CODE : 3276007037012

- FR** Manuel d'Instructions
- ES** Manual de Instrucciones
- PT** Manual de Instruções
- IT** Manuale di Istruzioni
- EL** Εγχειρίδιο Οδηγιών
- PL** Instrukcja Obsługi
- UA** Інструкція з Експлуатації
- RO** Manual de Instrucțiuni
- EN** Instructions Manual



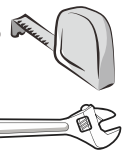
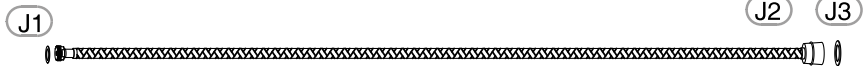
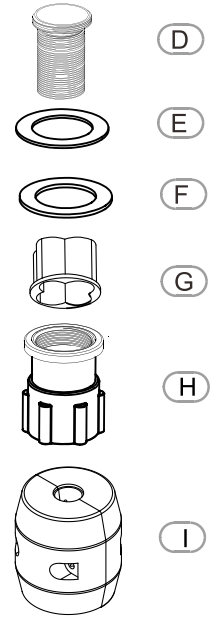
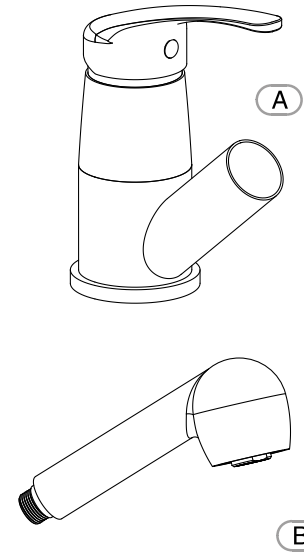
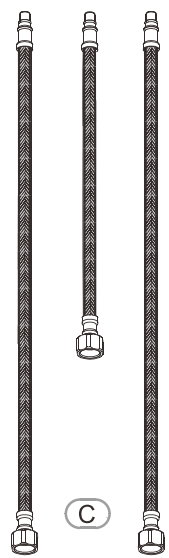
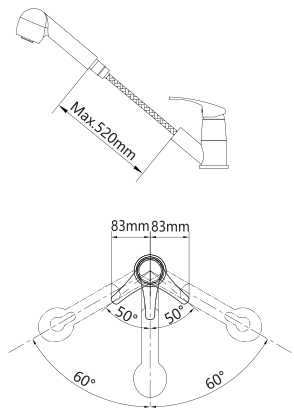
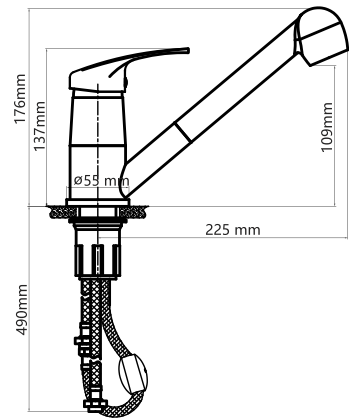

13 mm



1

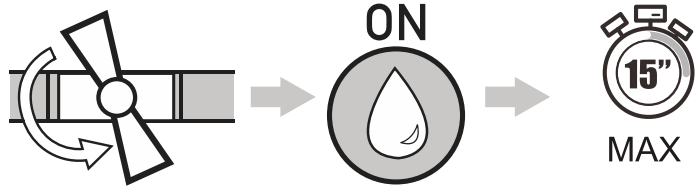

2

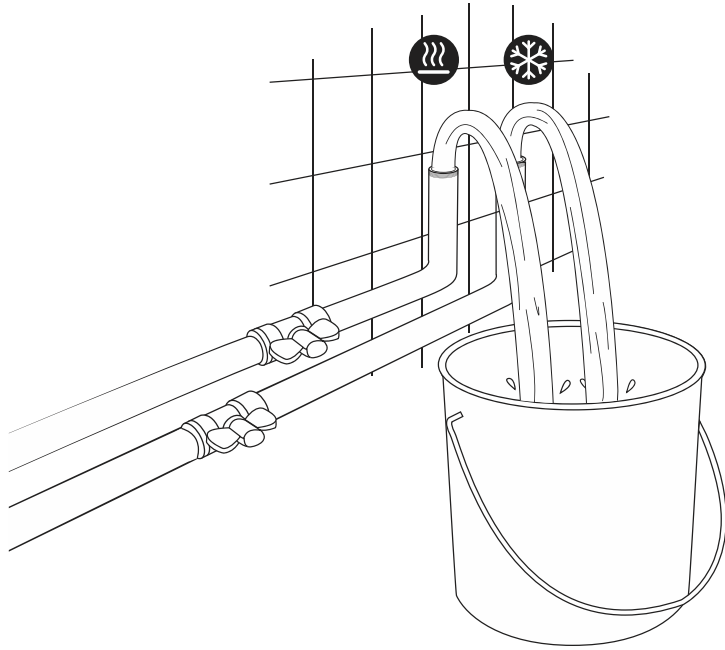

3

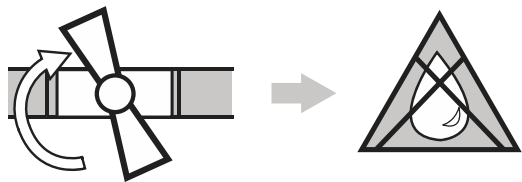

3



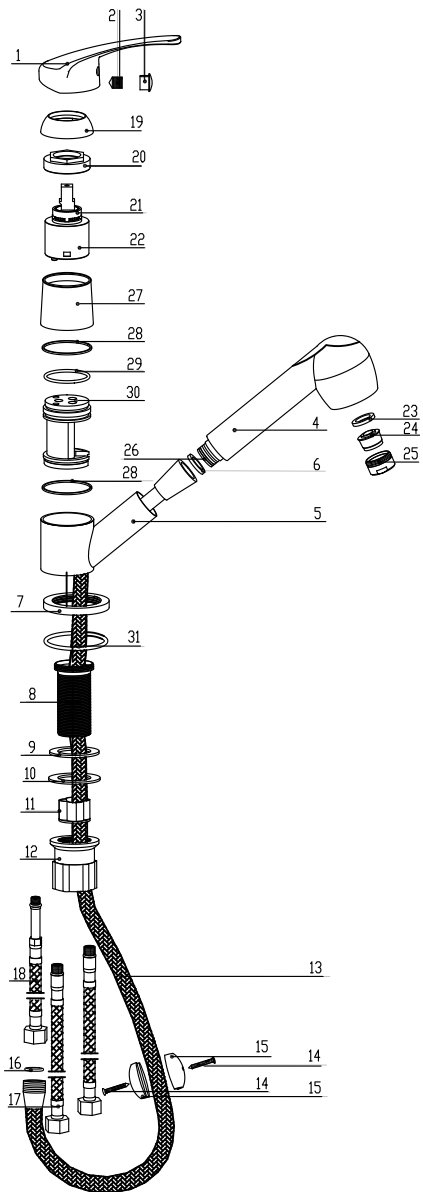

Part-Listing			
No.	Description	Material.	QTY
1	Handle	Zinc Alloy	1
2	Screw	Stainless Stell	1
3	Blue and Red Marker	ABS	1
4	Shower Head	POM/EPDM	1
5	Spout	Zinc Alloy	1
6	Washer	white Silicone	1
7	Base	Zinc Alloy	1
8	Install threaded sleeve	Stainless Stell	1
9	washer	NBR	1
10	Iron washer	Iron	1
11	Fixers	ABS	1
12	Nut	Brass/ABS	1
13	Shower Hose	PEX-b	1
14	Screw	Stainless Stell	2
15	Heavy Hammer	Brass/POM	1
16	Washer	white Silicone	1
17	Felexible Hose	S/S 304+pex	2
18	Felexible Hose	S/S 304+pex	1
19	Cover	ABS	1
20	Cartridge Nut	Brass (Hpb58-3)	1
21	Adjust ring	POM	1
22	Cartridge	Ceramic+POM	1
23	Washer	Silicone	1
24	Aerator	40.4606.000	1
25	Aerator housing	Brass	1
26	Check Valve	30.4043.000	1
27	Body	ZINC ALLOY	1
28	Balk ring	PTFE	2
29	O ring	Silicone	1
30	Cartridge Base	Brass	1
31	O ring	Silicone	1

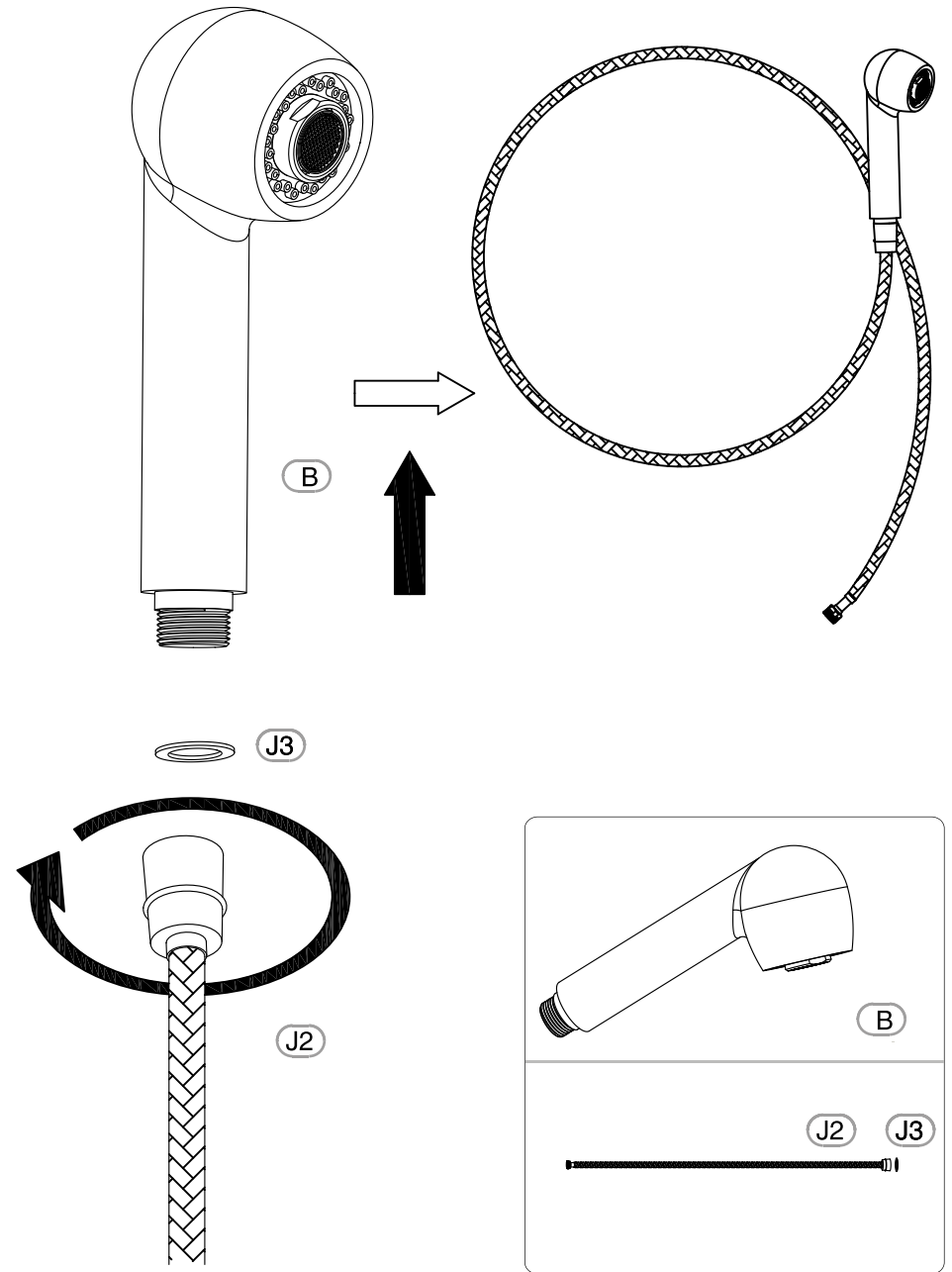

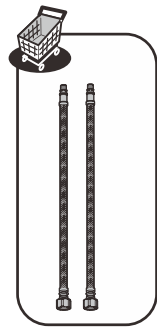
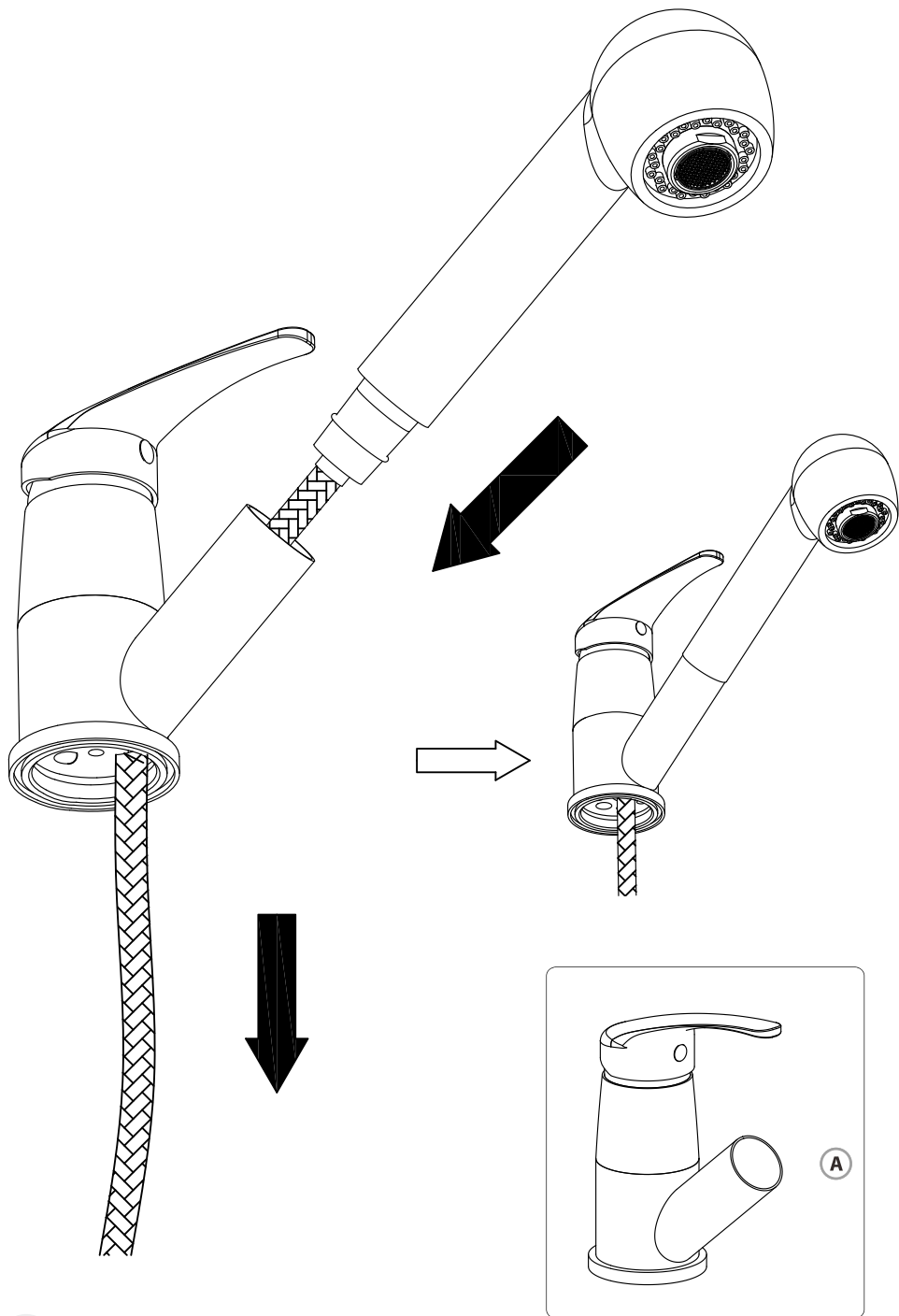

FR: Changement de flexibles/ ES: Cambio de flexibles / PT: Mudança de flexíveis/ IT: Cambio flessibili/  
 EL: Αλλαγή λάστιχων/ PL: Wymiana wężyków instalacyjnych /UA: Заміна гнучкого шланга для змішувача/  
 RO: Schimbare furtune flexibile/ EN: Replacing the hoses

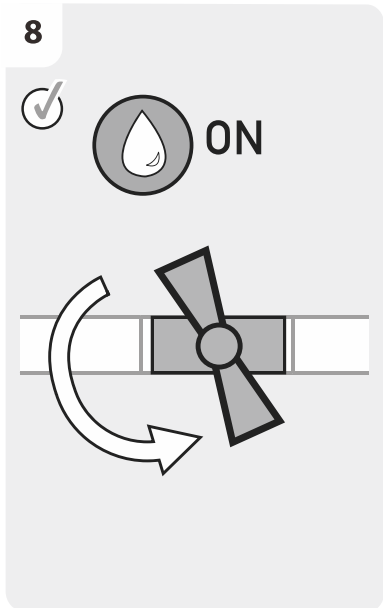
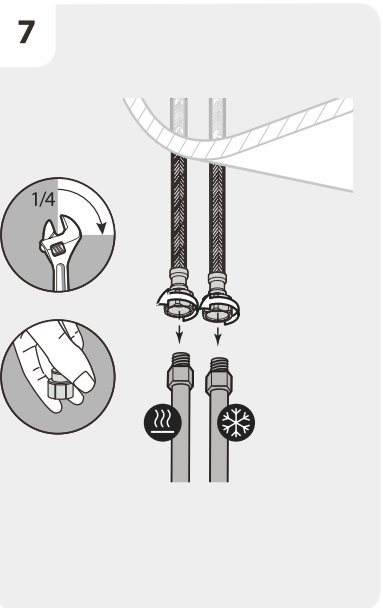
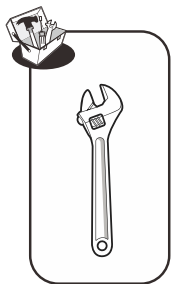
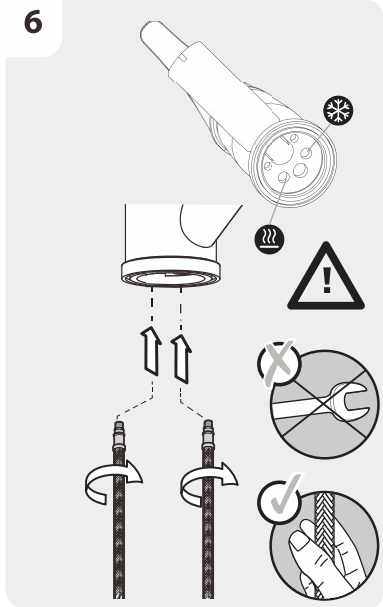
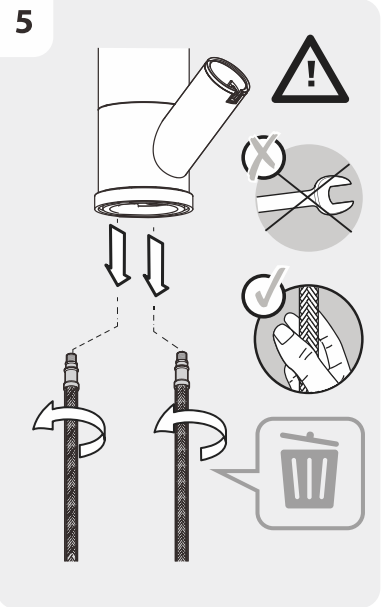

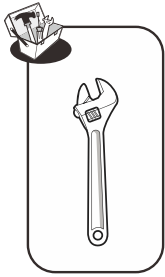

FR: Changement de flexibles/ ES: Cambio de flexibles / PT: Mudança de flexíveis/ IT: Cambio flessibili/  
EL: Αλλαγή λάστιχων/ PL: Wymiana wężyków instalacyjnych /UA: Заміна гнучкого шланга для змішувача/  
RO: Schimbare furtune flexibile/ EN: Replacing the hoses

1

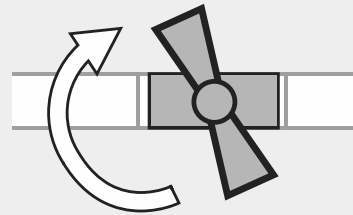

2

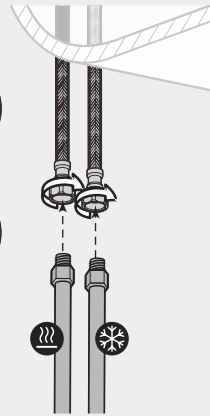

3

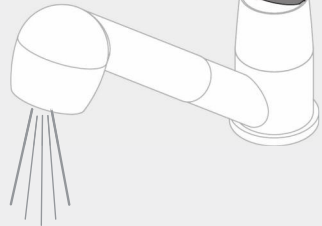
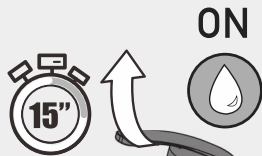

4

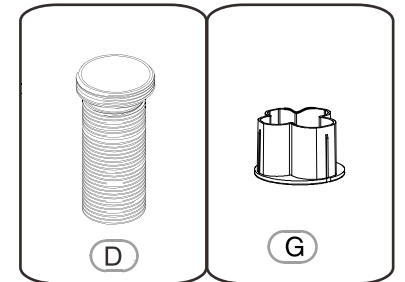
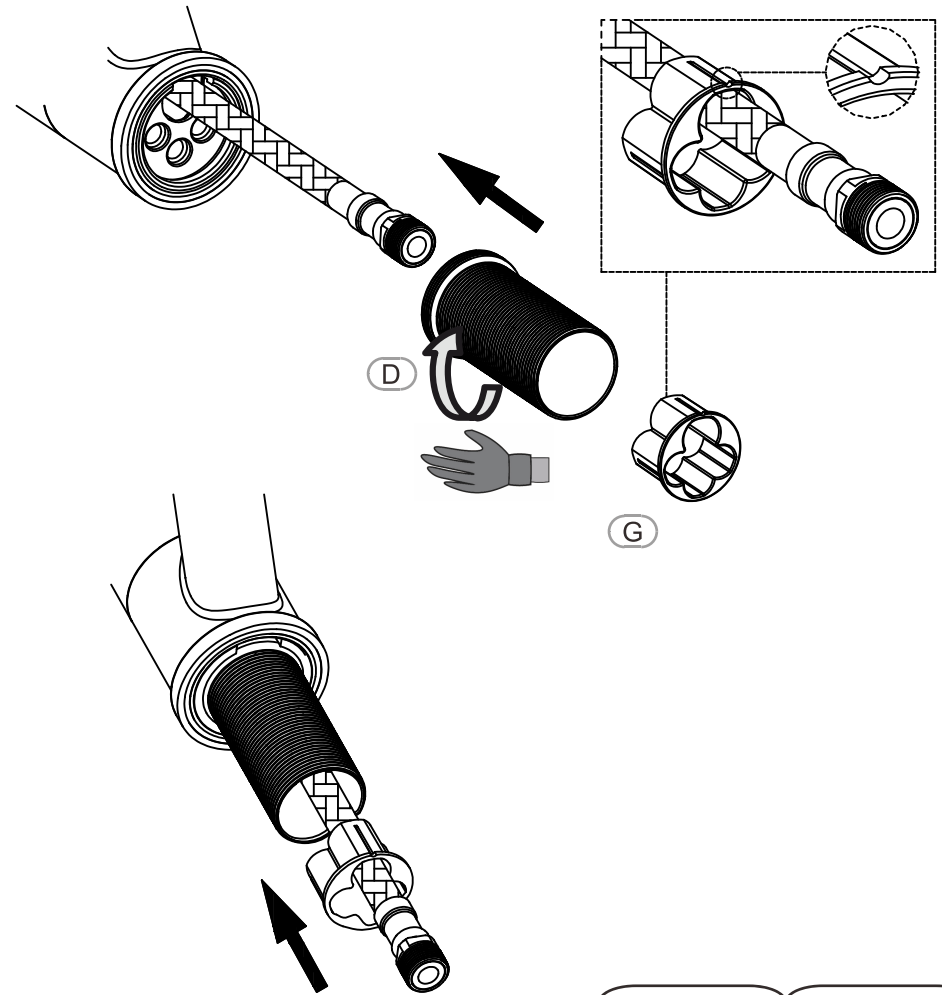
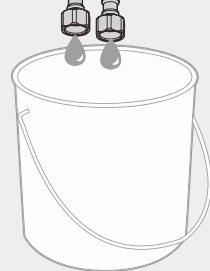

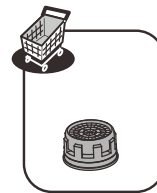
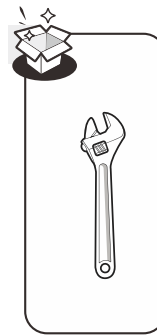
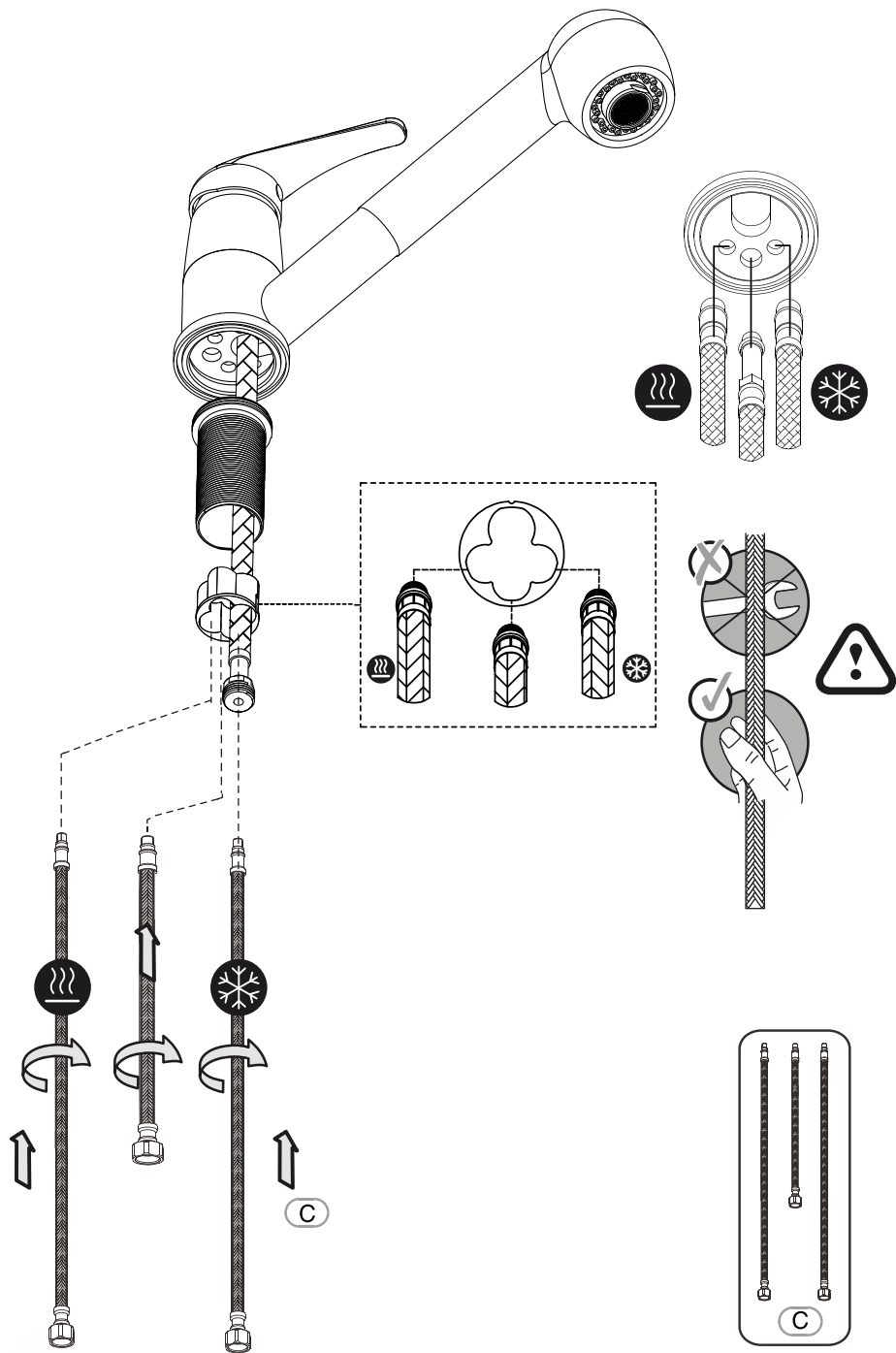

FR: Changement de mousseur/ ES: Cambio de aireador/ PT: Mudança de arejador/ IT: Cambio rompigetto/  
 EL: Αλλαγή αεράτορα / PL: Wymiana perlatora / UA: Заміна аерагора/ RO: Schimbare aerator/  
 EN: Replacing the aerator

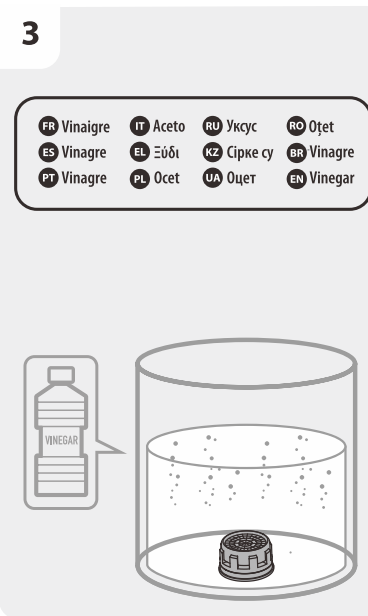
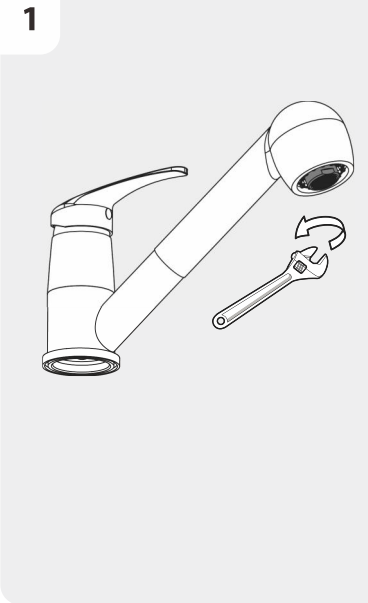



FR: Changement de cartouche/ ES: Cambio de cartucho/ IT: Cambio cartuccia/ PT: Mudança de cartucho/  
EL: Αλλαγή φουσιγγίου/ PL: Wymiana wkładu / UA: Заміна картриджа/ RO: Schimbare cartus/  
EN: Replacing the cartridge

13

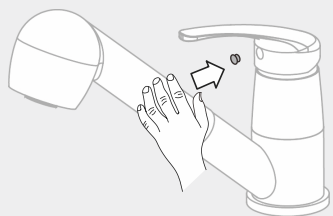

14



ON

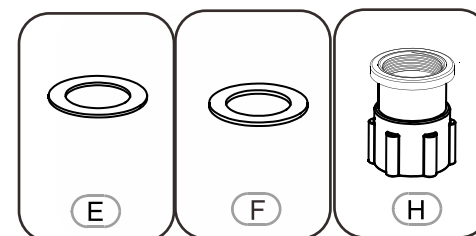
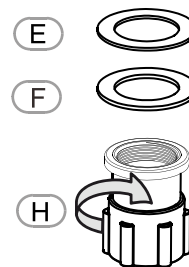
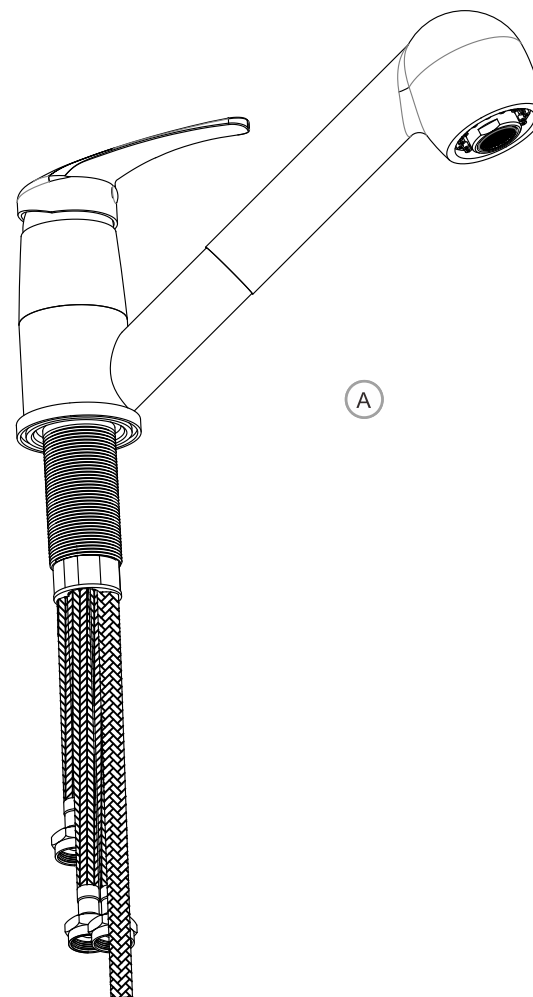
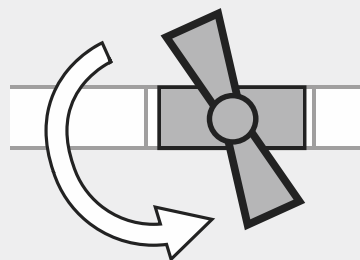

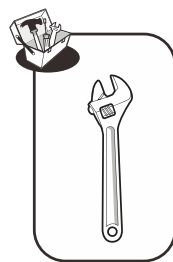
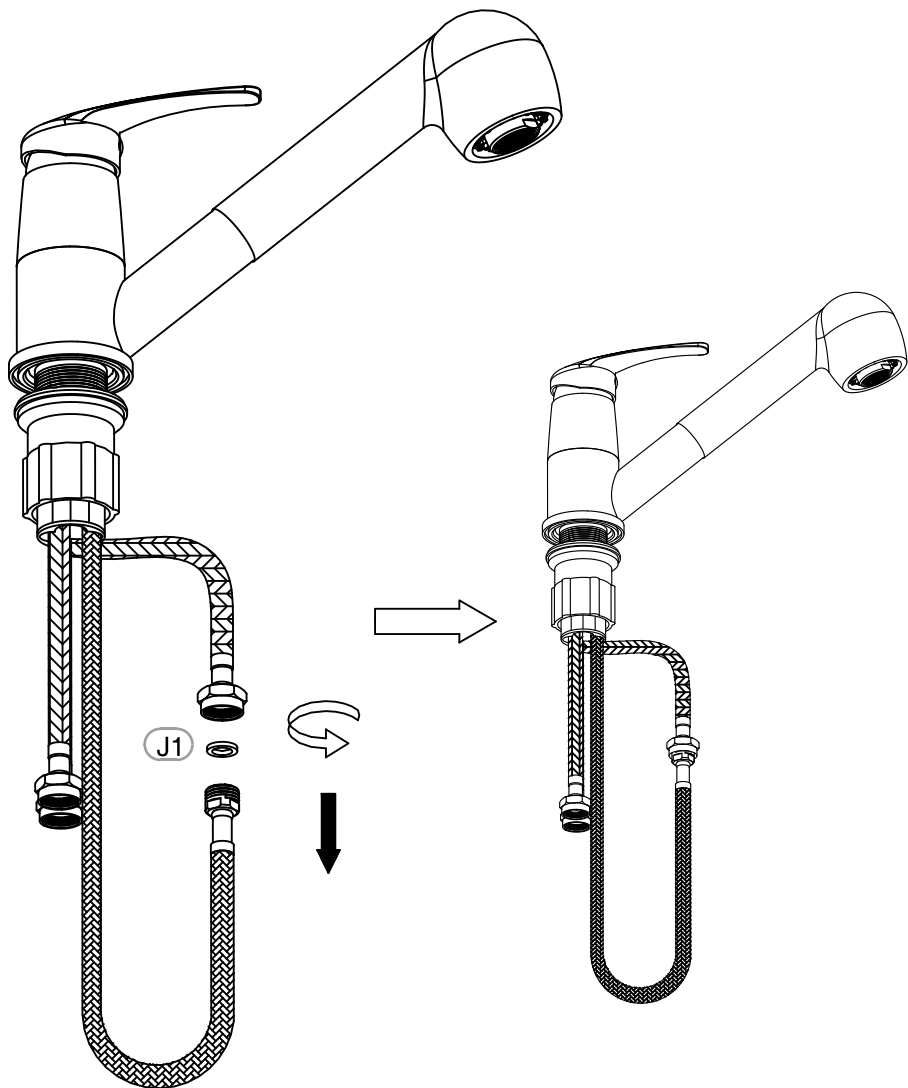

FR: Changement de cartouche/ ES: Cambio de cartucho/ IT: Cambio cartuccia/ PT: Mudança de cartucho/  
 EL: Αλλαγή φυσιγγίου/ PL: Wymiana wkładu / UA: Заміна картриджа/ RO: Schimbare cartuş/  
 EN: Replacing the cartridge

9



10

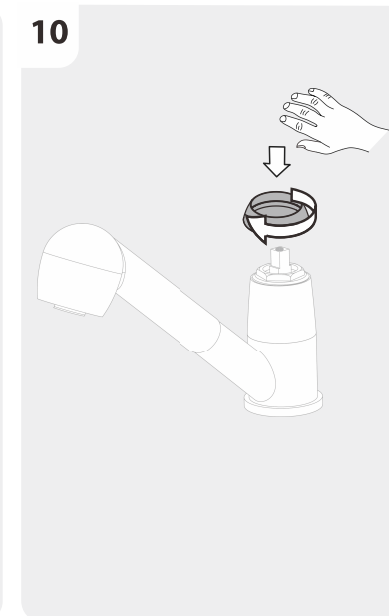

11



12

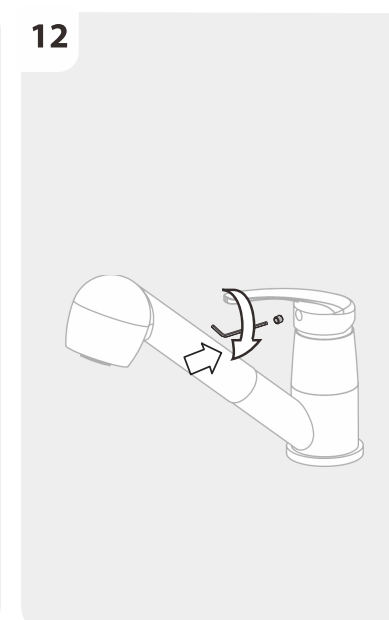

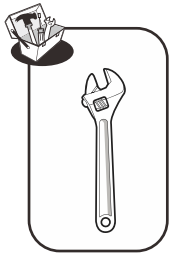

FR: Changement de cartouche/ ES: Cambio de cartucho/ IT: Cambio cartuccia/ PT: Mudança de cartucho/  
 EL: Αλλαγή φυσιγγίου/ PL: Wymiana wkładu / UA: Заміна картриджа/ RO: Schimbare cartus/  
 EN: Replacing the cartridge

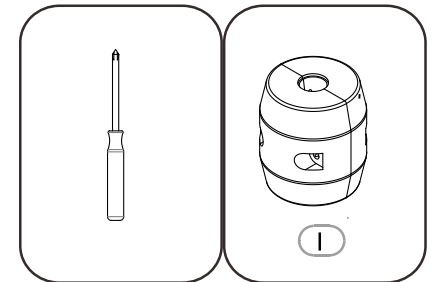
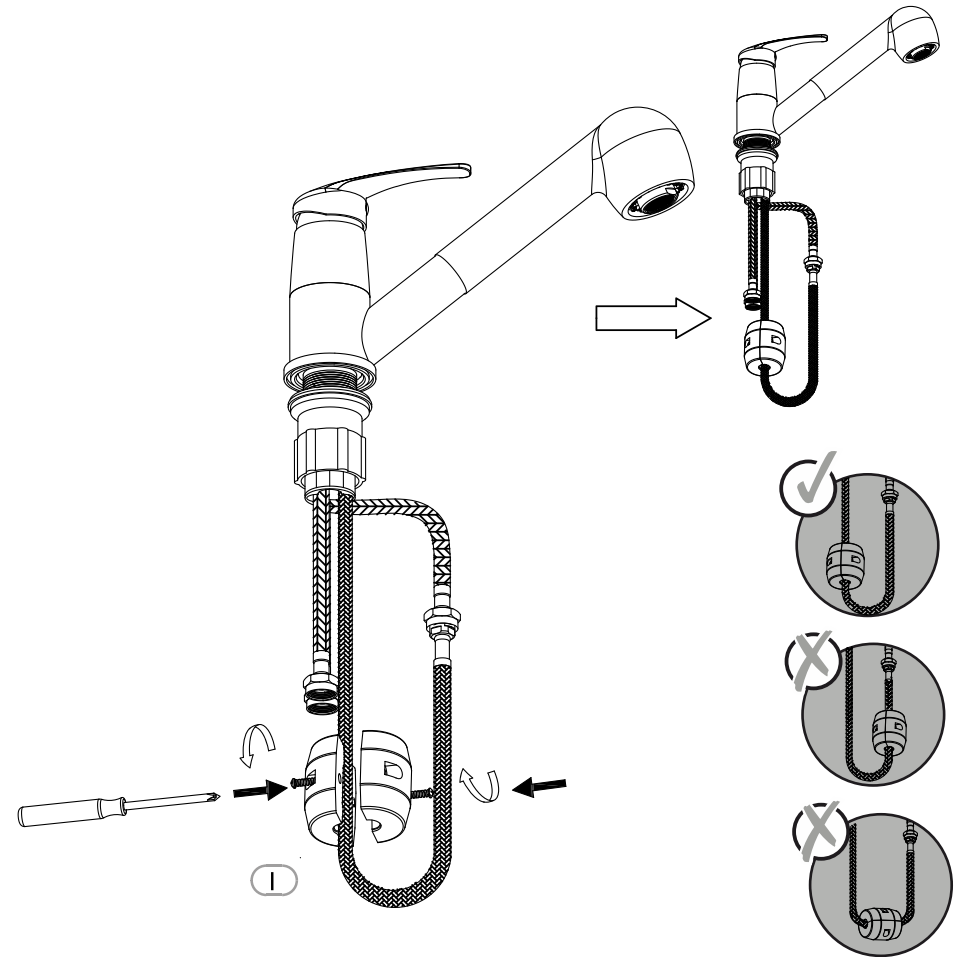
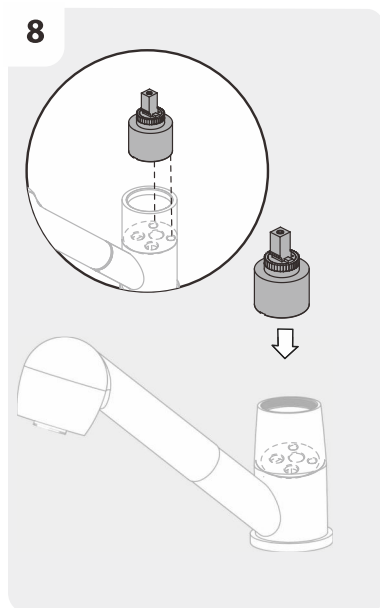
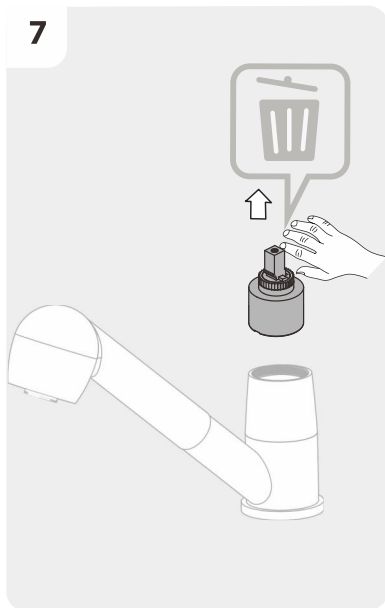
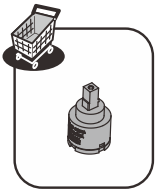
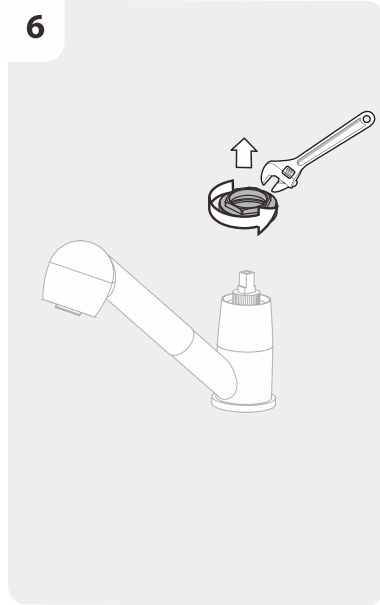
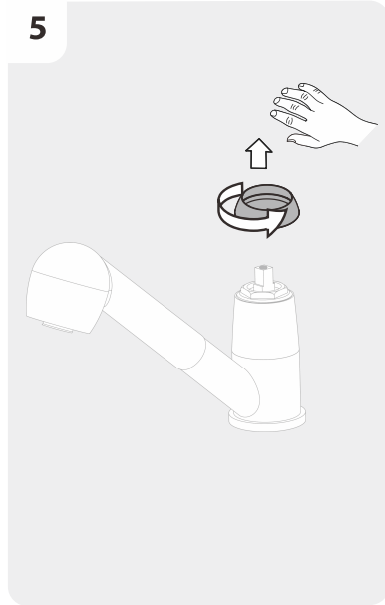



FR: Utilisation eau chaude-eau froide/ ES: Utilización agua caliente-agua fría/ PT: Utilização água quente-água fria/  
 IT: Uso acqua calda-acqua fredda/ EL: Χρήση ζεστού-κρύου νερού/ PL: Użytkowanie zimnej wody-gorącej wody/  
 UA: використання гарячої - холодної води/ RO: Utilizare apă caldă-apă rece/ EN: Using hot and cold water

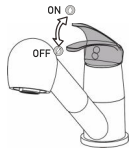

1

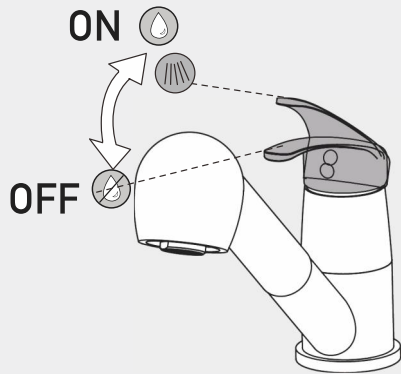

2

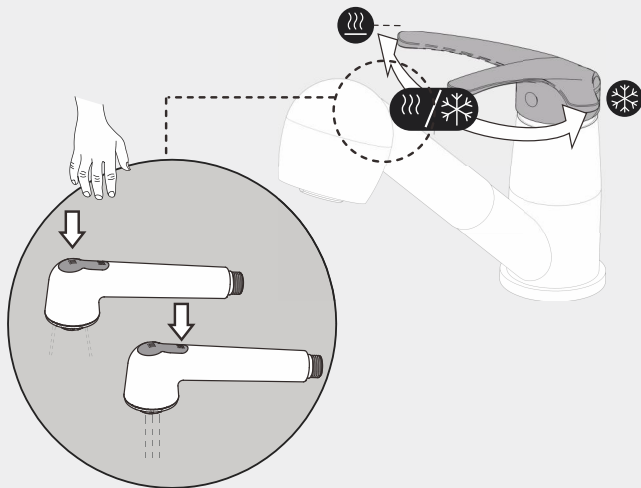

FR: Changement de cartouche/ ES: Cambio de cartucho/ IT: Cambio cartuccia/ PT: Mudança de cartucho/  
 EL: Αλλαγή φουσιγγίου/ PL: Wymiana wkładu / UA: Заміна картриджа/ RO: Schimbare cartus/  
 EN: Replacing the cartridge

1

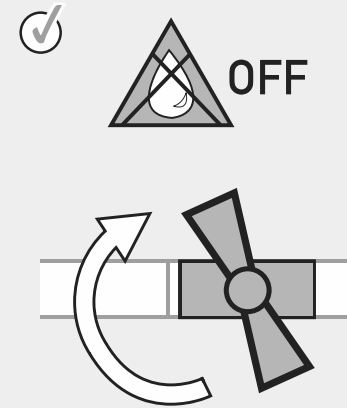

2

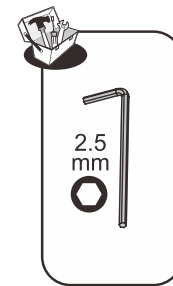
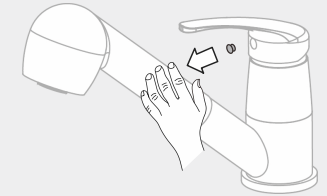

3

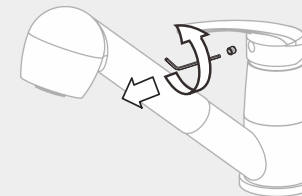

4

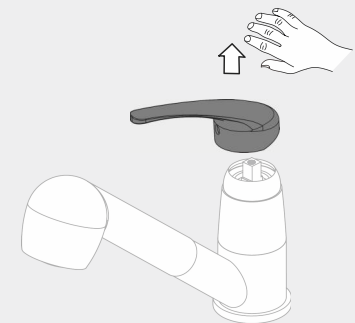





**OK**  
**TASK FORCE GREEN**  
**DOT / SORTING**  
**INSTRUCTION**  
**2021**