

EAN CODE: 3276007184334
3276007184341

FR Notice de Montage -
Utilisation - Entretien

ES Instrucciones de Montaje,
Utilización y Mantenimiento

PT Instruções de Montagem,
Utilização e Manutenção

IT Istruzioni per il Montaggio,
l'Uso e la Manutenzione

EL Εγχειρίδιο συναρμολόγησης,
χρήσης και συντήρησης

PL Instrukcja Montażu,
Użytkowania i Konserwacji

RU Руководство По Сборке
и Эксплуатации

KZ Жинау, пайдалану және
техникалық Қызмет
көрсету нұсқаулығы

UA Керівництво По Збірці
і Експлуатації

RO Manual asamblare,
utilizare și întreținere

BR Instruções de Montagem,
Utilização e Manutenção

EN Assembly - Use -
Maintenance Manual

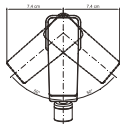
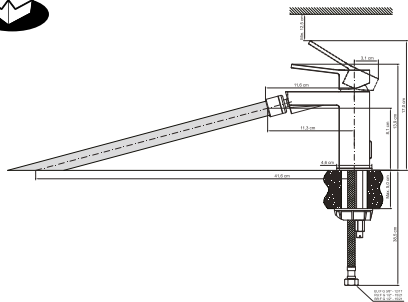

C

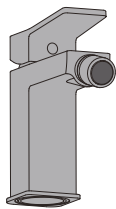

A



B



D



E



F

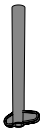

G





FR: Préparation / ES: Preparación / PT: Preparação / IT: Preparazione / EL: Προετοιμασία /
 PL: Przygotowanie / RU: Подготовка / KZ: Дайындау / UA: Підготування / RO: Pregătire / BR: Preparação /
 EN: Preparation



FR: Montage / ES: Montaje / PT: Montagem / IT: Montaggio / EL: Συναρμολόγηση /
 PL: Montaż / RU: Сборка / KZ: Монтаждау / UA: Збірка / RO: Montaj / BR: Montagem /
 EN: Assembly



FR: Utilisation eau chaude-eau froide/ ES: Utilización agua caliente-agua fría/ PT: Utilização água quente-água fria/
 IT: Uso acqua calda-acqua fredda/ EL: Χρήση ζεστού-κρύου νερού/ PL: Użytkowanie zimnej wody-gorącej wody/
 RU: использование горячей и холодной воды/ KZ: Суық және ыстық суды қолдану/
 UA: використання гарячої-холодної води/ RO: Utilizare apă caldă-apă rece/ BR: Uso de água quente e fria/
 EN: Using hot and cold water



FR: Changement de cartouche/ ES: Cambio de cartucho/ IT: Cambio cartuccia/ PT: Mudança de cartucho/
 EL: Αλλαγή φυσιγγίου/ PL: Wymiana wkładu / RU: Смена картриджа/ KZ: Картриджді ауыстыру/
 UA: Заміна картриджа/ RO: Schimbare cartuş/ BR: Substituição de cartucho/ EN: Replacing the cartridge

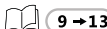

FR: Changement de mousseur/ ES: Cambio de aireador/ PT: Mudança de arejador/ IT: Cambio rompigetto/
 EL: Αλλαγή αεράτορα / PL: Wymiana perlatora / RU: Смена аэратора/ KZ: Ауақанықтырғышты ауыстыру/
 UA: Заміна аератора/ RO: Schimbare aerator/ BR: Substituição do aerador/ EN: Replacing the aerator



FR: Changement de flexibles/ ES: Cambio de flexibles / PT: Mudança de flexíveis/ IT: Cambio flessibili/
 EL: Αλλαγή λάστιχων/ PL: Wymiana wężyków instalacyjnych / RU: Смена гибкого шланга для смесителя/
 UA: Заміна гнучкого шланга для змішувача/ KZ: Қоспалауышқа арналған иілгіш шлангты ауыстыру/
 RO: Schimbare furtune flexibile/ BR: Substituição das mangueiras/ EN: Replacing the hoses

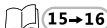

FR:* Si la pression est supérieure à 5 bars, il est nécessaire de rajouter un réducteur de pression / ES:*
 Si la presión es superior a 5 bars, es necesario añadir un reductor de presión. / PT:* Se a pressão for
 superior a 5 bars, será necessário acrescentar um redutor de pressão / IT:* Se la pressione è superiore
 a 5 bar, bisogna aggiungere un riduttore di pressione / EL:* Εάν η πίεση υπερβαίνει τα 5 bars, είναι
 απαραίτητη η προσθήκη μειωτή πίεσης / PL:* Jeśli ciśnienie jest wyższe niż 5 barów, należy dodać reductor
 ciśnienia / RU:* Если давление превышает 5 бар, необходимо добавить редуктор давления / KZ:*
 Егер қысым 5 бардан асатын болса, қысым бәсеңдеткішін қосу қажет / UA:* Якщо тиск перевищує
 5 бар, необхідно додати редуктор тиску / RO:* Dacă presiunea este mai mare de 5 bari, este necesar
 să adăugați un reductor de presiune / BR:* Se a pressão for superior a 5 bar, é necessário adicionar um
 reductor de pressão / EN:* If the pressure is over 5 bars, a pressure reducing valve must be added.



FR: Préparation / ES: Preparación / PT: Preparação / IT: Preparazione / EL: Προετοιμασία /
PL: Przygotowanie / RU: Подготовка / KZ: Дайындау / UA: Підготовка / RO: Pregătire /
BR: Preparação / EN: Preparation

1

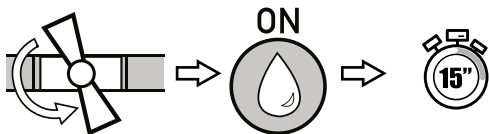

2

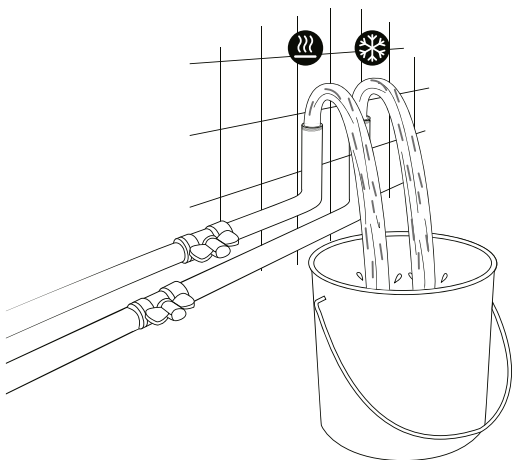

3

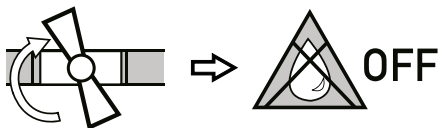

FR: Montage / ES: Montaje / PT: Montagem / IT: Montaggio / EL: Συναρμολόγηση /
 PL: Montaż / RU: Сборка / KZ: Монтаждау / UA: Збірка / RO: Montaj / BR: Montagem /
 EN: Assembly

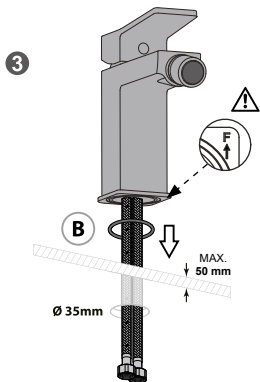
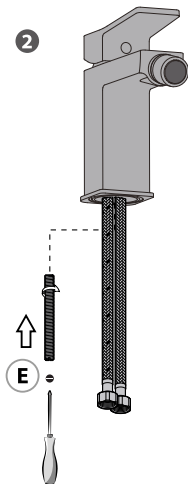
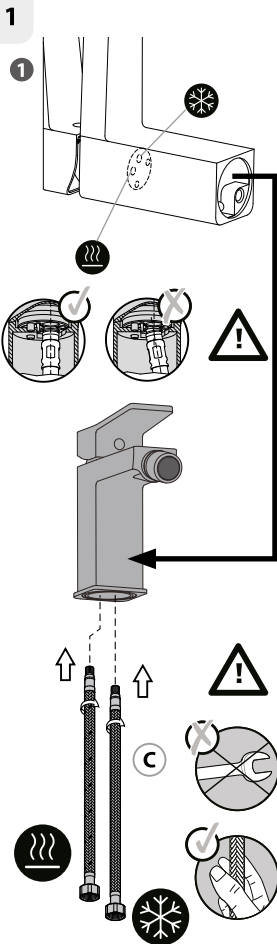
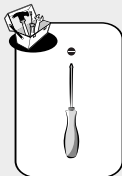
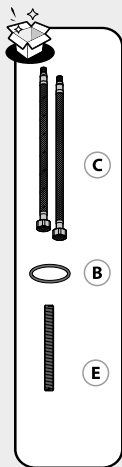

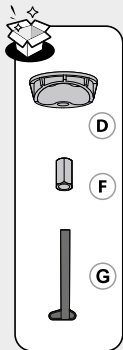

2

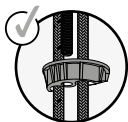
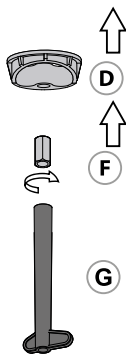
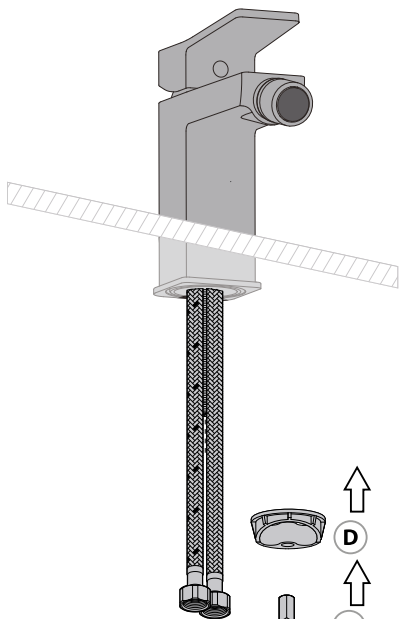

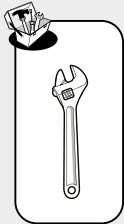

3

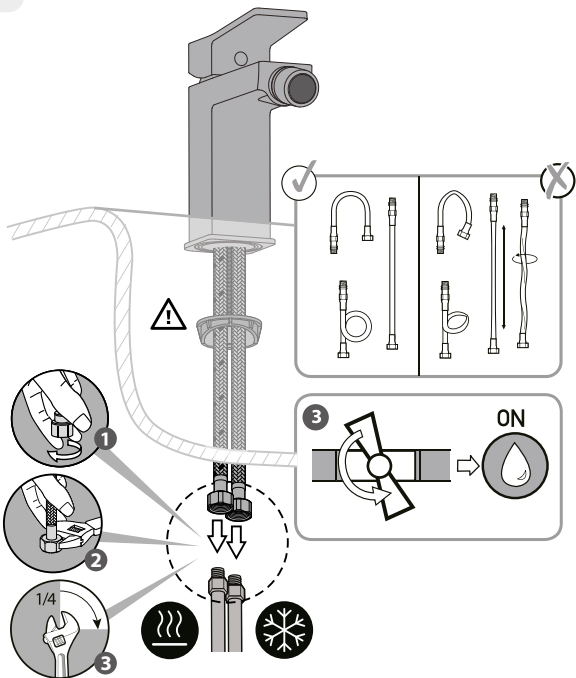



FR: Utilisation eau chaude-eau froide/ **ES:** Utilización agua caliente-agua fría/ **PT:** Utilização água quente-água fria/
IT: Uso acqua calda-acqua fredda/ **EL:** Χρήση ζεστού-κρύου νερού/ **PL:** Użytkowanie zimnej wody-gorącej wody/
RU: использование горячей и холодной воды/ **KZ:** Суық және ыстық суды қолдану/
UA: використання гарячої - холодної води/ **RO:** Utilizare apă caldă-apă rece/ **BR:** Uso de água quente e fria/
EN: Using hot and cold water

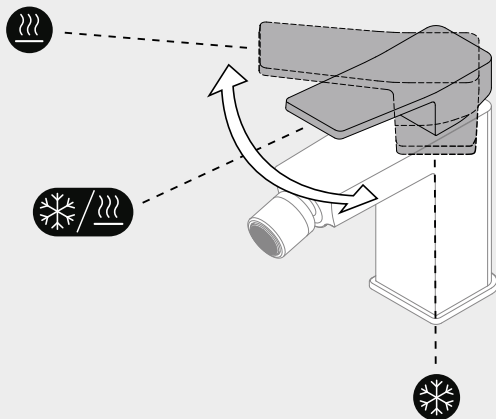
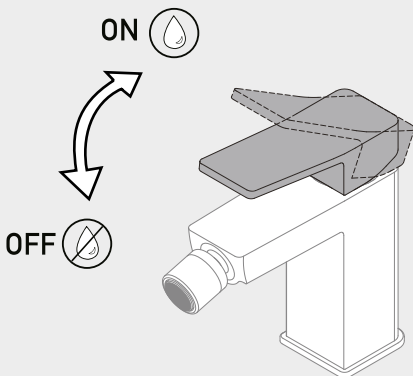

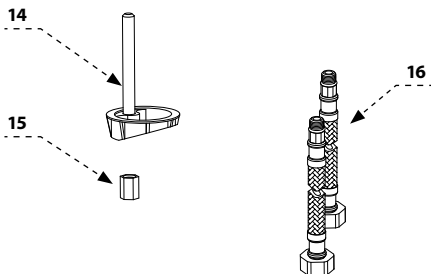
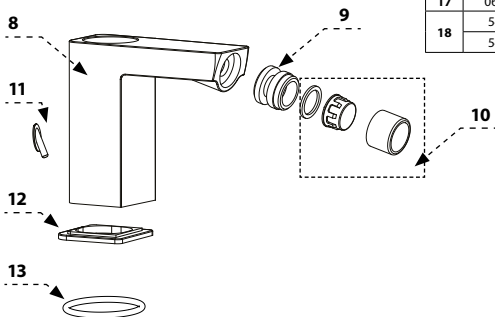
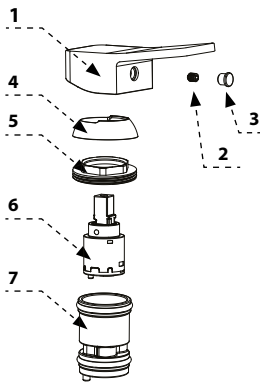

No.	EAN		QTY
	3276007184334	3276007184334	
1	0724509CR	0724509N	1
2	0731952	0731952	1
3	0621623	0621623	1
4	0671284CR	0671284N	1
5	0633421	0633421	1
6	0802829	0802829	1
7	0802426	0802426	1
8	0717519CR	0717519N	1
9	0899575CR	0899575N	1
10	40200203301	0899576N	1
11	0653105CR	0653105N	1
12	0759685CR	0759685N	1
13	0621150	0621150	1
14	0723191T	0723191T	1
15	0733168T	0733168T	1
16	0615915	0615915	1
17	0615915	0615915	1
18	544000	544000	2
	544001	544001	



FR: Changement de cartouche/ ES: Cambio de cartucho/ IT: Cambio cartuccia/ PT: Mudança de cartucho/
EL: Αλλαγή φουσιγγίου/ PL: Wymiana wkładu / RU: Смена картриджа/ KZ: Картриджді ауыстыру/
UA: Заміна картриджа/ RO: Schimbare cartuş/ BR: Substituição de cartucho/ EN: Replacing the cartridge

1



OFF

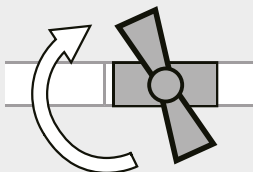

2

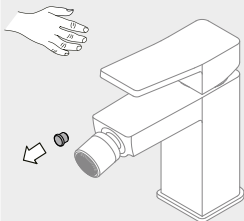

3

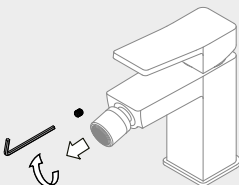

4

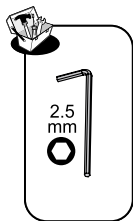
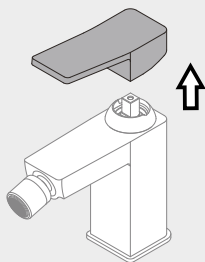

2.5
mm

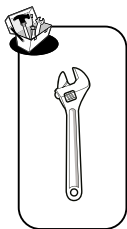

FR: Changement de cartouche/ ES: Cambio de cartucho/ IT: Cambio cartuccia/ PT: Mudança de cartucho/
EL: Αλλαγή φουσιγγίου/ PL: Wymiana wkładu / RU: Смена картриджа/ KZ: Картриджді ауыстыру/
UA: Заміна картриджа/ RO: Schimbare cartuş/ BR: Substituição de cartucho/ EN: Replacing the cartridge

5

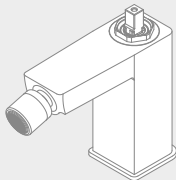

6

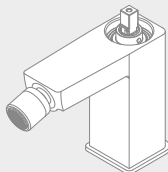
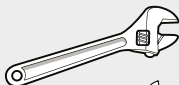

7

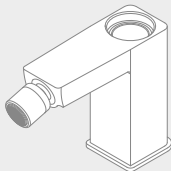

8

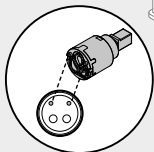
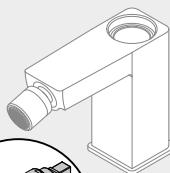

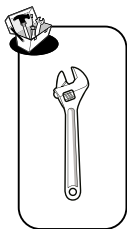

FR: Changement de cartouche/ ES: Cambio de cartucho/ IT: Cambio cartuccia/ PT: Mudança de cartucho/
EL: Αλλαγή φιασίγγιου/ PL: Wymiana wkładu / RU: Смена картриджа/ KZ: Картриджді ауыстыру/
UA: Заміна картриджа/ RO: Schimbare cartuş/ BR: Substituição de cartucho/ EN: Replacing the cartridge

9

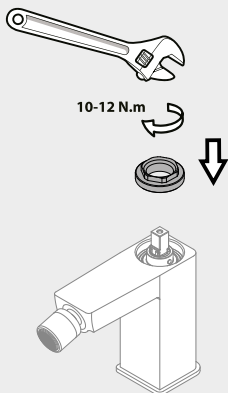

10

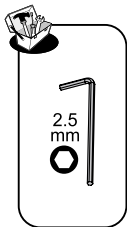
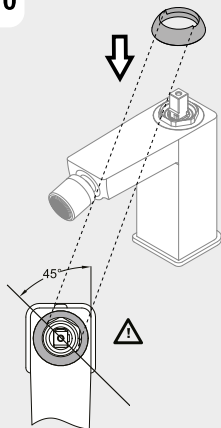

11

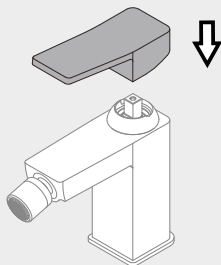

12

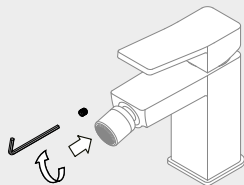



FR: Changement de cartouche/ **ES:** Cambio de cartucho/ **IT:** Cambio cartuccia/ **PT:** Mudança de cartucho/
EL: Αλλαγή φουσιγγίου/ **PL:** Wymiana wkładu / **RU:** Смена картриджа/ **KZ:** Картриджді ауыстыру/
UA: Заміна картриджа/ **RO:** Schimbare cartuş/ **BR:** Substituição de cartucho/ **EN:** Replacing the cartridge

13

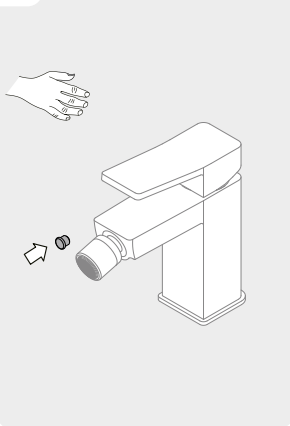

14

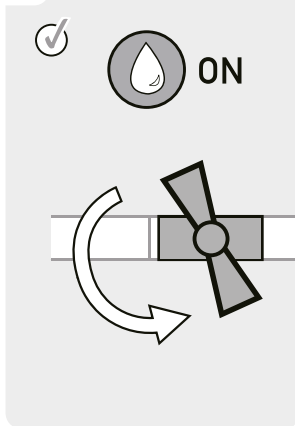



FR: Changement de mousseur/ **ES:** Cambio de aireador/ **PT:** Mudança de arejador/ **IT:** Cambio rompigitto/
EL: Αλλαγή αεράτορα / **PL:** Wymiana perlatora / **RU:** Смена аэратора/ **KZ:** Ауақанықтырғышты ауыстыру/
UA: Заміна аератора/ **RO:** Schimbare aerator/ **BR:** Substituição do aerador/ **EN:** Replacing the aerator

1

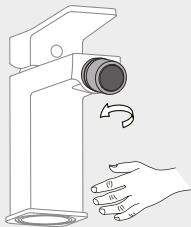

2

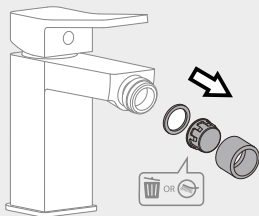

- | | | | |
|---|---------------------|-----------------------|--------------------|
|  | FR Nettoyage | EL Καθαρισμός | UA Очищення |
| | ES Limpieza | PL Czyszczenie | RO Curățare |
| | PT Limpeza | RU Чистка | BR Limpeza |
| | IT Pulizia | KZ тазарту | EN Cleaning |

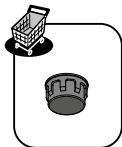

3

- | | | | |
|--------------------|-----------------|--------------------|-------------------|
| FR Vinaigre | IT Aceto | RU Уксус | RO Oțet |
| ES Vinagre | EL Ξίδι | KZ Сірке су | BR Vinagre |
| PT Vinagre | PL Ocet | UA Оцет | EN Vinegar |

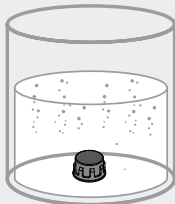

4

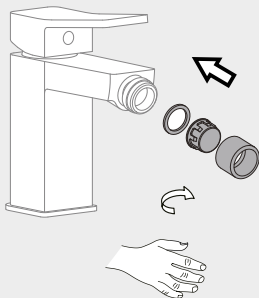

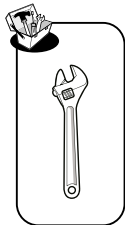

FR: Changement de flexibles/ ES: Cambio de flexibles/ PT: Mudança de flexíveis/ IT: Cambio flessibili/
EL: Αλλαγή λάστιχων/ PL: Wymiana wężyków instalacyjnych / RU: Смена гибкого шланга для смесителя/
UA: Заміна гнучкого шланга для змішувача/ KZ: Қоспалауышқа арналған иілгіш шлангты ауыстыру/
RO: Schimbare furtune flexibile/ BR: Substituição das mangueiras/ EN: Replacing the hoses

1

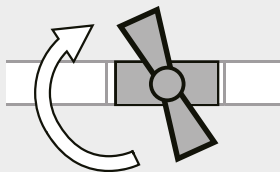

2

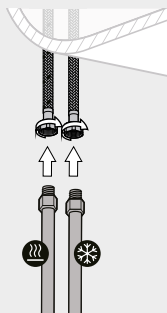

3

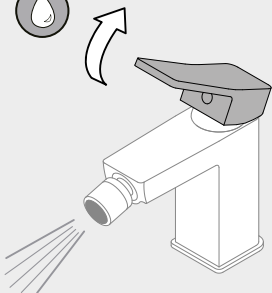

4

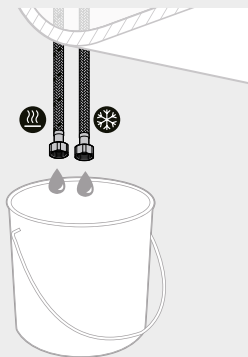

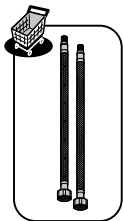
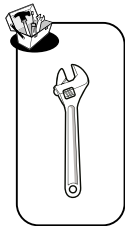

FR: Changement de flexibles/ ES: Cambio de flexibles/ PT: Mudança de flexíveis/ IT: Cambio flessibili/
EL: Αλλαγή λάστιχων/ PL: Wymiana wężyków instalacyjnych / RU: Смена гибкого шланга для смесителя/
UA: Заміна гнучкого шланга для змішувача/ KZ: Қоспалауышқа арналған илгіш шлангты ауыстыру/
RO: Schimbare furtune flexibile/ BR: Substituição das mangueiras/ EN: Replacing the hoses

5

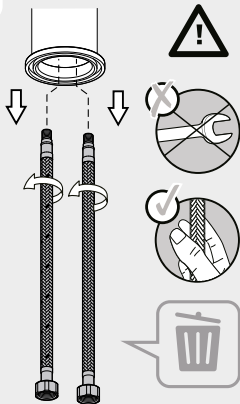

6

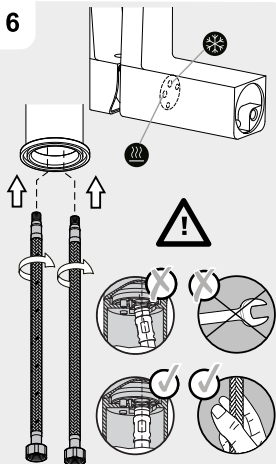

7

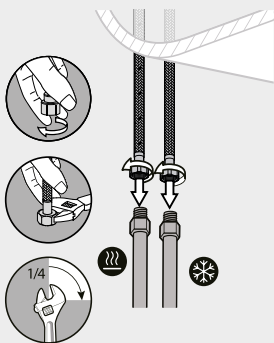

8

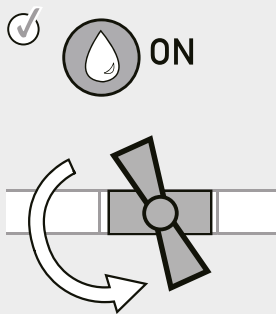



Eau claire / Agua limpia / Água limpa / Acqua pulita / Καθαρό νερό / Czysta woda / Чистая вода / Água limpa /
Чиста вода / Apa curata / таза су / Clean water



Sans solvant / Sin disolvente / Sem solventes / Senza solventi / Χωρίς διαλυτικά / Bez rozpuszczalnika / Без растворителя /
Sem solventes/ Без розчинника / Fara solvent / еріткішсіз/ Solvent-free

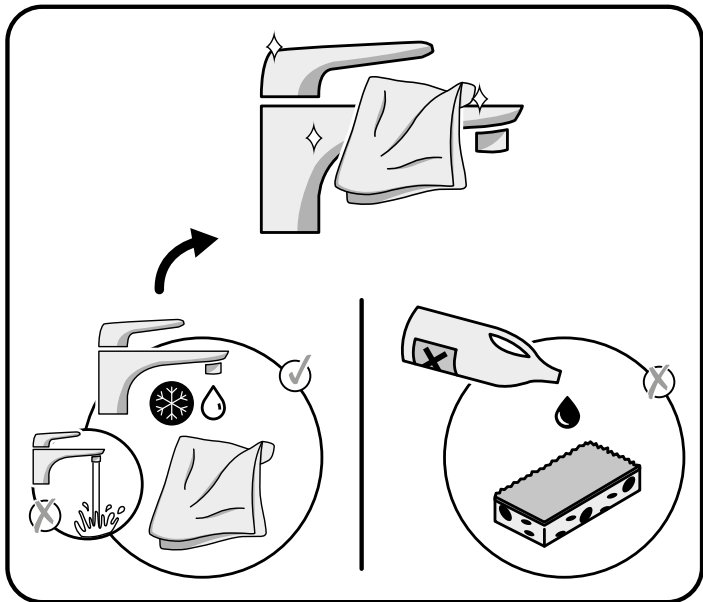

- FR** Pour une consommation d'eau adaptée, ce robinet est équipé d'un mousseur à économie d'eau.
- ES** Este grifo cuenta con un aireador de ahorro de agua para un adecuado consumo de agua.
- PT** Para um consumo adequado de água, esta torneira está equipada com um arejador que economiza água.
- IT** Per un consumo d'acqua più adatto, questo rubinetto dispone di un rompigetto per economizzare l'acqua.
- EL** Για μια καλά ρυθμισμένη κατανάλωση νερού, αυτή η μπαταρία είναι εξοπλισμένη με ένα φίλτρο εξοικονόμησης νερού.
- PL** Aby zapewnić optymalne zużycie wody, kran ten jest wyposażony w perlator oszczędzający wodę.
- RU** Для правильного потребления воды этот кран оснащен водосберегающим аэратором.
- KZ** Суды дұрыс тұтыну мақсатында бұл шүмек суды үнемдейтін аэратормен жабдықталған.
- UA** Для правильного споживання води цей кран оснащений водозберігаючим аератором.
- RO** Pentru un consum adecvat de apă, acest robinet este echipat cu un aerator de economisire a apei.
- BR** Para um consumo adequado de água, essa torneira está equipada com um aerador para economia de água.
- EN** For an adequate water consumption, this tap is fitted with an eco aerator for water savings.



- FR** Attestation de conformité sanitaire
- ES** Certificado de conformidad sanitaria.
- PT** Atestado de conformidade sanitária.
- IT** certificato di conformità sanitaria.
- EL** Βεβαίωση υγειονομικής συμμόρφωσης.
- PL** Certyfikat zgodności sanitarnej.
- RU** Декларация о соответствии санитарным нормам
- KZ** Санитарлық талаптарға сәйкестік декларациясы
- UA** Декларація про відповідність санітарним нормам
- RO** Atestat de conformitate sanitară
- BR** Certificado de conformidade sanitária.
- EN** Declaration of sanitary conformity.



* Garantie 10 ans / 10 años de garantía / Garantia de 10 anos / Garanzia 10 Anni / Εγγύηση 10 ετών / Gwarancja 10-letnia / Гарантия 10 года / Кепілдік 10 жыл / Гарантія 10 років / Garantie 10 ani / 10-year guarantee



2020

BY Поставщик/импортер/организация, принимающая претензии по качеству товара в Республике Беларусь: ООО «Леруа Мерлен Бел», 220020, Республика Беларусь, г. Минск, пр-т Победителей, д. 100, каб. 503

FR ADEO Services - 135 Rue Sadi Carnot - CS 00001 59790 RONCHIN - France

UA ТОВ «Леруа Мерлен Україна», вул. Полярна 17а, м. Київ 04201, Україна

RU ООО ЛЕРУА МЕРЛЕН ВОСТОК, 141031, Московская область, г. Мытищи, Осташковское шоссе, д.1, РОССИЯ

BR Importado e distribuído por LEROY MERLIN CIA BRASILEIRA DE BRICOLAGEM Rua Domingos Galletet Blotta, 315 - Interlagos - CEP 04455-360 São Paulo - SP - Brazil CNPJ: 01.438.784/0001-05 CALM (Central de Atendimento Leroy Merlin) -4020.5376 (capitais) e 0800.0205376 (demais regiões)

SA Imported by Adeo South Africa (PTY) LTD T/A Leroy Merlin Leroy Merlin Greenstone Store - Corner Blackrock Street and Stoneridge Drive, Greenstone Park Ext 2, Edenvale, 1610 - Johannesburg, Gauteng, South Africa

KZ «Леруа Мерлен Қазақстан» ЖШС Қазақстан Республикасы, 050000, Алматы қ, Қонаев көшесі, 77, «ParkView» БО, 6к, 07 об.



HI420P