

**EASY**



- FR** Nous vous remercions d'avoir acheté ce produit. Nous vous conseillons de lire attentivement la notice d'installation, d'utilisation et d'entretien. Nous avons conçu ce produit pour vous apporter entière satisfaction. Si vous avez besoin d'aide l'équipe de votre magasin est à votre disposition pour vous accompagner.
- ES** Le agradecemos haber comprado este producto. Le recomendamos leer atentamente el manual de instalación, uso y mantenimiento. Este producto ha sido diseñado para proporcionarle plena satisfacción. Si necesita alguna ayuda, el personal de la tienda estará a su disposición para guiarle.
- PT** Agradecemos a sua preferência por este produto . Aconselhamo-lo a ler o manual de instalação , utilização , e manutenção com atenção. Criámos este produto para sua completa satisfação. Se precisar de ajuda, a equipa da sua loja está à sua disposição para o acompanhar.
- IT** Grazie per aver acquistato questo prodotto. Vi raccomandiamo di leggere attentamente il manuale di installazione, utilizzo e manutenzione. Questo prodotto è stato progettato per offrirvi la massima soddisfazione. Per ricevere assistenza, il personale del punto vendita è a vostra disposizione.
- EL** Ευχαριστούμε για την αγορά σας αυτού του προϊόντος. Σας συμβουλεύουμε να διαβάσετε προσεκτικά τις οδηγίες εγκατάστασης, χρήσης και συντήρησης. Σχεδιάσαμε αυτό το προϊόν για να σας προσφέρει πλήρη ικανοποίηση. Αν χρειάζεστε βοήθεια, η ομάδα του καταστήματος από το οποίο αγοράσατε το προϊόν είναι στη διάθεσή σας.
- PL** Dziękujemy za zakup produktu firmy. Zalecamy, aby uważanie przeczytać instrukcję instalacji, użytkowania i konserwacji. Ten produkt marki zaprojektowaliśmy, aby spełnić wszystkie panstwa oczekiwania. W razie potrzeby pracownicy sklepu służą Państwu pomocą i są do Państwa dyspozycji.
- UA** Дякуємо вам за покупку цього виробу. Ми радимо вам уважно прочитати інструкції з устанвлення, експлуатації та технічного обслуговування. Ми розробили цей виріб для того, щоб він приносив вам задоволення. Якщо вам потрібна допомога, співробітники вашого магазину готові допомігти вам.
- RO** Vă mulțumim pentru achiziționarea acestui produs . Vă sfatuim să citiți cu atenție instrucțiunile de instalare, de utilizare și de întreținere. Am conceput acest produs pentru a vă furniza satisfacție totală. Dacă aveți nevoie de ajutor, echipa magazinului de cumpărare este la dispoziția dumneavoastră pentru a vă asista.
- BR** Obrigado por ter adquirido um produto . Nós aconselhamos a ler atentamente o manual de instalação, uso e manutenção. Concebemos um produto para proporcionar total satisfação. Caso precise de ajuda, a equipe da sua loja estará à disposição para te acompanhar.
- EN** Thank you for purchasing this product. We recommend that you read the installation, user and maintenance instructions carefully. We have designed this product to ensure your complete satisfaction. If you require assistance, the team at your retailer is on hand to help you.

<b>FR</b>	Plan de la notice	<b>PL</b>	Plan instrukcji
<b>ES</b>	Esquema del folleto	<b>UA</b>	План інструкції
<b>PT</b>	Plano de instruções	<b>RO</b>	Planul instrucțiunilor
<b>IT</b>	Piano delle istruzioni	<b>BR</b>	Esboço do folheto
<b>EL</b>	Σχέδιο οδηγιών	<b>EN</b>	Overview of the guide

IMPORTANT, à conserver pour consultation ultérieure : à lire attentivement

IMPORTANTE, conservar para consultar posteriormente : leer atentamente

IMPORTANTE, conservar para futuras consultas : por favor, leia com atenção

IMPORTANTE, da conservare per ulteriore consultazione : da leggere attentamente

ΣΗΜΑΝΤΙΚΟ, κρατήστε το για μελλοντική αναφορά. Διαβάστε το προσεκτικά

WAŻNE, przeczytać uważnie i zachować na przyszłość

ВАЖЛИВО, збережіть для подальшого використання. Уважно прочитайте

IMPORTANT, a se pastra pentru consultarea ulterioara: citiți cu atenție

IMPORTANTE, por favor manter para referência futura: leia com atenção

IMPORTANT, to be retained for future reference: please read carefully

**01** **FR**: Matériel - **ES**: Material - **PT**: Material - **IT**: Materiale  
**EL**: Υλικό - **PL**: Materiał - **UA**: Матеріал - **RO**: Material  
**BR**: Material - **EN**: Equipment 

**02** **FR**: Montage - **ES**: Montaje - **PT**: Montagem - **IT**: Montaggio  
**EL**: Συναρμολόγηση - **PL**: Montaż - **UA**: Збірка - **RO**: Montaj  
**BR**: Montagem - **EN**: Assembly 

**03** **FR**: Utilisation - **ES**: Utilización - **PT**: Utilização - **IT**: Uso  
**EL**: Χρήση - **PL**: Użytkowanie - **UA**: Використання - **RO**: Utilizare  
**BR**: Uso - **EN**: Using 

**04** **FR**: Entretien - **ES**: Mantenimiento - **PT**: Manutenção - **IT**: Manutenzione  
**EL**: Συντήρηση - **PL**: Konserwacja - **UA**: Технічне обслуговування  
**RO**: Întreținere - **BR**: Manutenção - **EN**: Maintenance 

**05** **FR**: Changement de cartouche - **ES**: Cambio de cartucho  
**PT**: Mudança de cartucho - **IT**: Cambio cartuccia - **EL**: Αλλαγή φυσιγγίου  
**PL**: Wymiana wkładu - **UA**: Заміна картриджа  
**RO**: Schimbare cartuș - **BR**: Substituição de cartucho  
**EN**: Replacing the cartridge 

**06** **FR**: Changement de cartouche - **ES**: Cambio de cartucho  
**PT**: Mudança de cartucho - **IT**: Cambio cartuccia - **EL**: Αλλαγή φυσιγγίου  
**PL**: Wymiana wkładu - **UA**: Заміна картриджа  
**RO**: Schimbare cartuș - **BR**: Substituição de cartucho  
**EN**: Replacing the cartridge 

**07** **FR**: Changement de tapis - **ES**: Cambio de la alfombra  
**PT**: Substituição do tapete - **IT**: Sostituzione del tappetino  
**EL**: Αλλαγή ταπητά - **PL**: Wymiana maty - **UA**: Заміна килимка  
**RO**: Înlocuirea covorului - **BR**: Troca do tapete - **EN**: Changing the mat 





**Min. 1 Bar**  
**Max. 10 Bar**

👍 2-5\* Bar



**Max. 70°C**

👍 65°C

**Max dif. COLD-HOT :**  
**< 2 Bar**

- FR** \*Si la pression est supérieure à 5 bar, il est nécessaire de rajouter un réducteur de pression.  
**ES** \*Si la presión es superior a 5 bar, es necesario añadir un reductor de presión.  
**PT** \*Se a pressão for superior a 5 bar, será necessário acrescentar um reductor de pressão.  
**IT** \*Se la pressione è superiore a 5 bar, bisogna aggiungere un riduttore di pressione.  
**EL** \*Εάν η υπερβαίνει τα 5 bar, είναι απαραίτητη η προσθήκη μειωτή πίεσης.  
**PL** \*Jeśli ciśnienie jest wyższe niż 5 barów, należy dodać reduktor ciśnienia.  
**UA** \*Якщо тиск перевищує 5 бар, необхідно додати редуктор тиску.  
**RO** \*Dacă presiunea este mai mare de 5 bari, este necesar să adăugați un reductor de presiune.  
**BR** \*Se a pressão for superior a 5 bar, é necessário adicionar um reductor de pressão.  
**EN** \*If the pressure is over 5 bar, a pressure reducing valve must be added.

- FR** La présence sur ce robinet d'un ou plusieurs clapet(s) anti retour est nécessaire au bon fonctionnement de l'ensemble de votre installation en eau. Ne tentez pas de le(s) retirer.
- ES** La presencia en este grifo de una o de varias válvula(s) de retención es necesaria para el buen funcionamiento del conjunto de su instalación de agua. No intente retirarla(s).
- PT** A presença nesta torneira de uma ou mais válvula(s) de retenção é necessária para o funcionamento adequado de toda a instalação de Água. Não tente removê-la(s).
- IT** La presenza su questo rubinetto di una o più valvole anti riflusso è necessaria per il buon funzionamento della totalità del vostro impianto in acqua. Non tentare di rimuoverle.
- EL** Η παρουσία σε αυτήν την μπαταρία, μίας ή περισσότερών, βαλβίδων αντεπιστροφής είναι απαραίτητη για την καλή λειτουργία του συνόλου της υδραυλικής σας εγκατάστασης. Μην επιχειρήσετε να τις αποσπάσετε.
- PL** Obecność jednego lub więcej zaworów zwrotnych kranu jest niezbędna dla prawidłowego funkcjonowania całej instalacji wodnej. Nie należy ich usuwać.
- UA** Наявність на цьому крані одного або декількох зворотних клапанів необхідна для правильної роботи всієї водопровідної установки. Не намагайтеся його/їх знімати.
- RO** Prezența pe această robinet a unei sau mai multor supape de reținere este necesară pentru buna funcționare a întregii dvs. instalații de apă. Nu încercați să le eliminați.
- BR** A presença de uma ou mais válvula(s) anti-retorno nessa torneira é necessária para o funcionamento adequado da sua instalação de água. Não tente remover a(s) válvula(s).
- EN** The presence of one or more anti-return valve(s) on this tap is required for proper operation of your water setup. Please do not attempt to remove it/them.

# 01

FR Matériel  
ES Material  
PT Material  
IT Materiale  
EL Υλικό

PL Materiał  
UA Матеріал  
RO Material  
BR Material  
EN Equipment

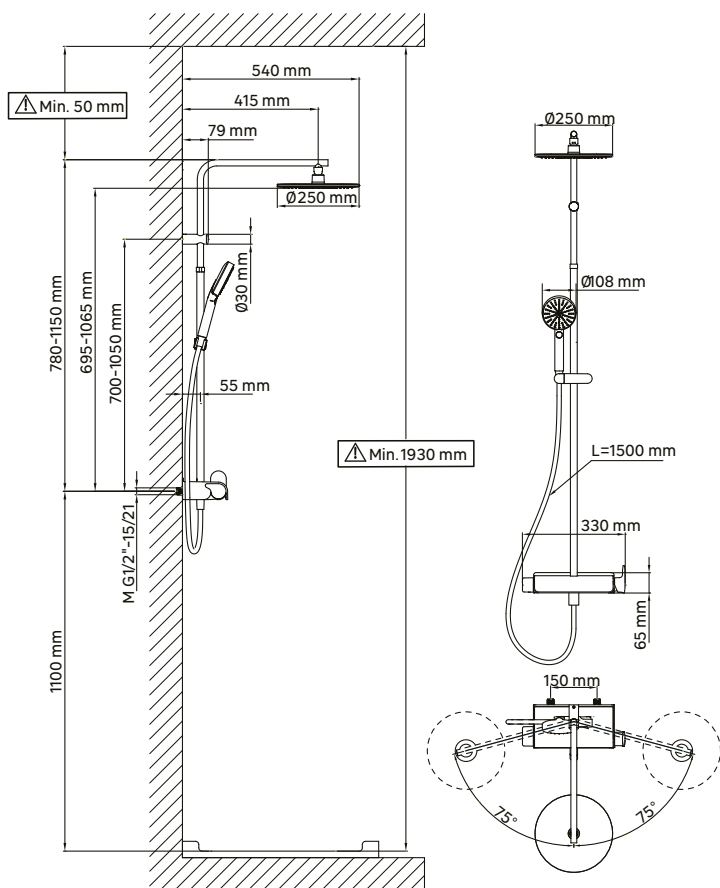

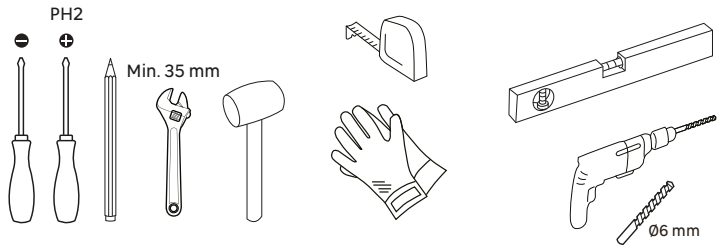
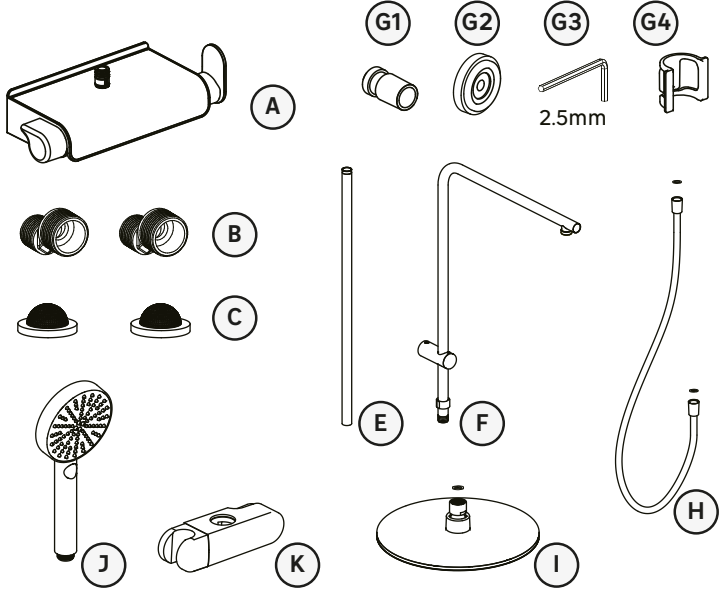
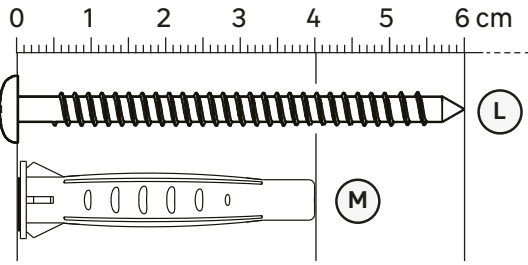

# 02

FR Montage  
ES Montaje  
PT Montagem  
IT Montaggio  
EL Συναρμολόγηση

PL Montaz  
UA Збірка  
RO Montaj  
BR Montagem  
EN Assembly

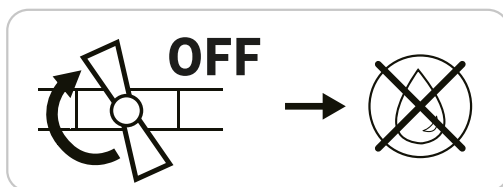
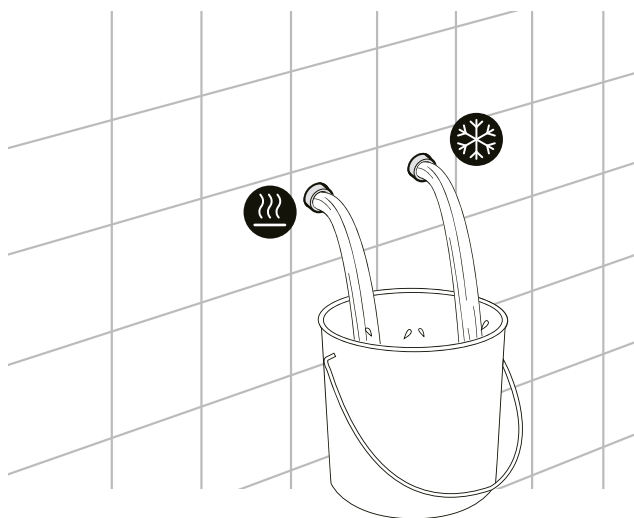
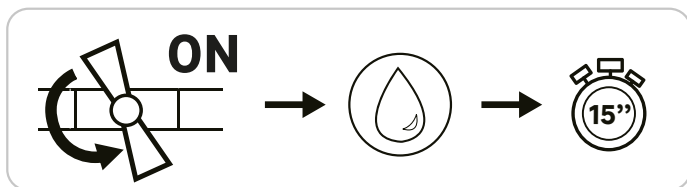



**B**

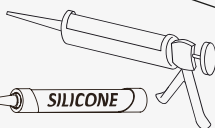
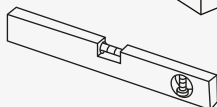
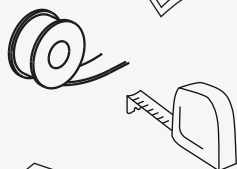
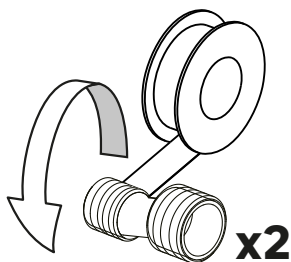

Min. 35 mm

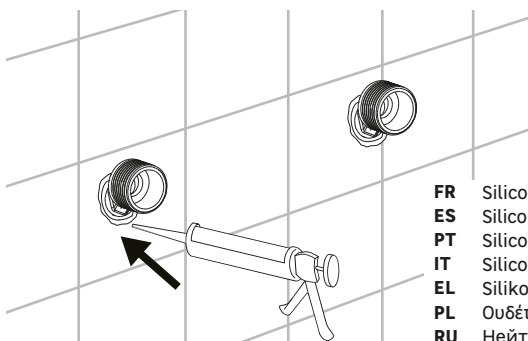
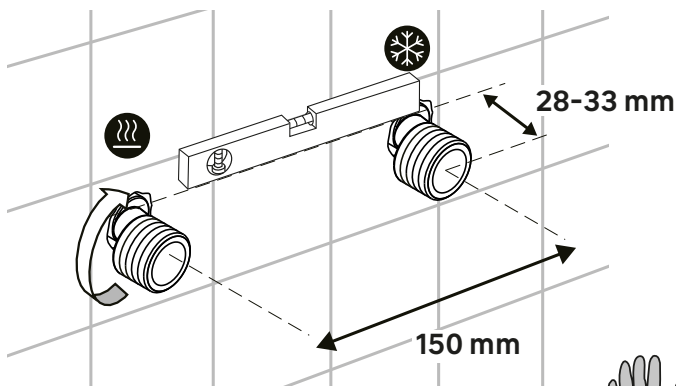
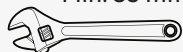

- FR Silicone neutre
- ES Silicona neutra
- PT Silicone neutro
- IT Silicone neutro
- EL Σιλίκону ουδέτερου
- PL Ουδέτερη σιλίκονη
- RU Нейтральный силикон
- KZ Бейтарап силикон
- UA Нейтральний силікон
- RO Silicon neutru
- BR Silicone neutro
- EN Neutral silicone

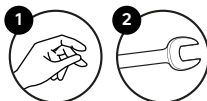
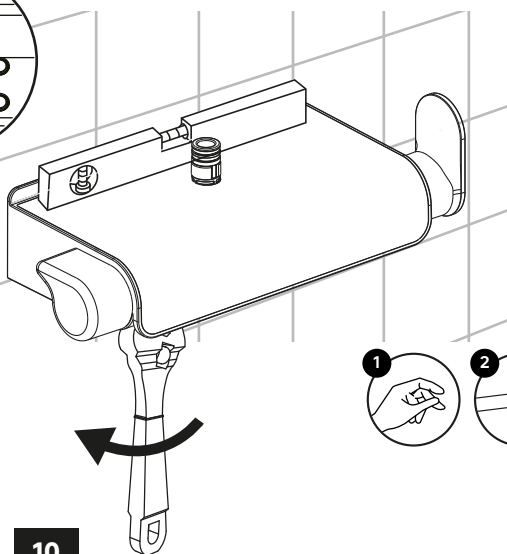
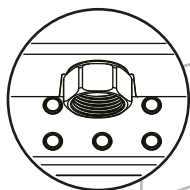
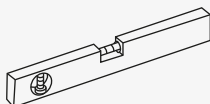
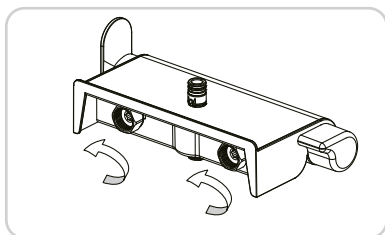
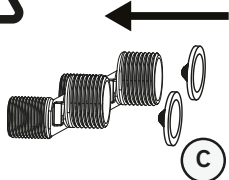
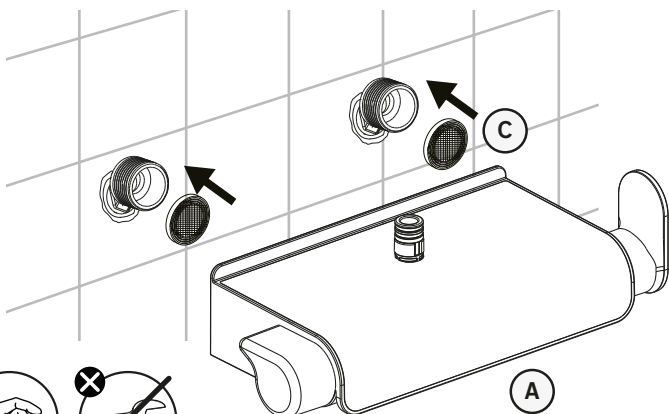
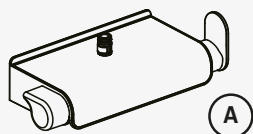

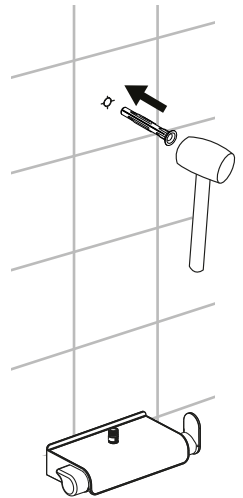
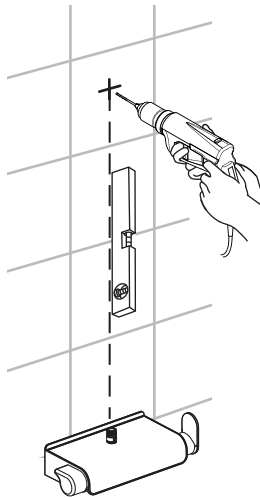
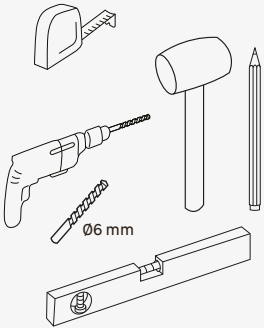
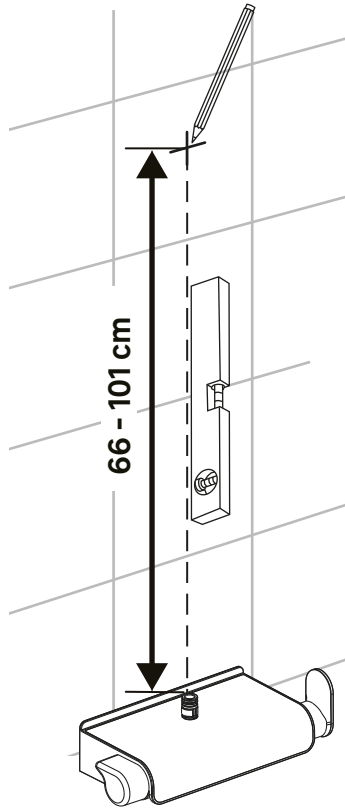
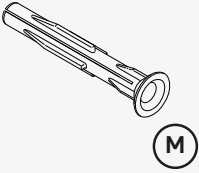

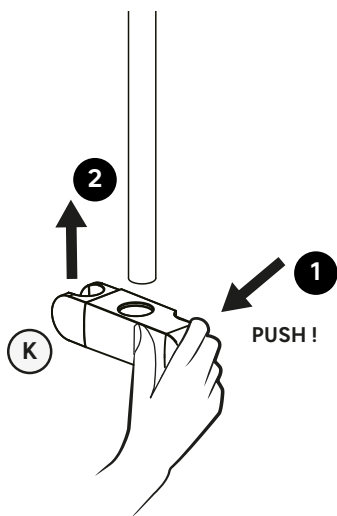
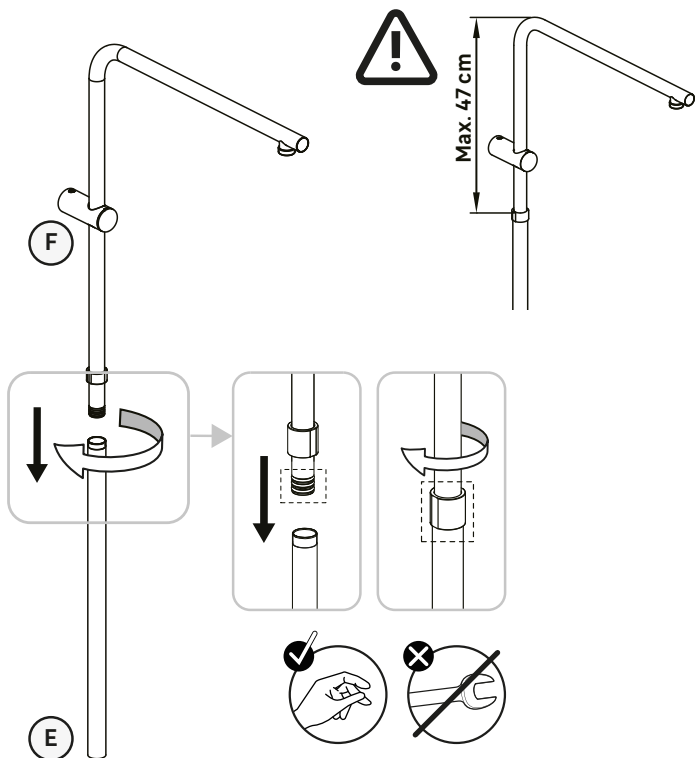
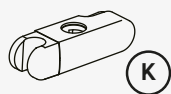
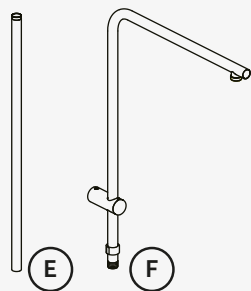





L



G1



G2

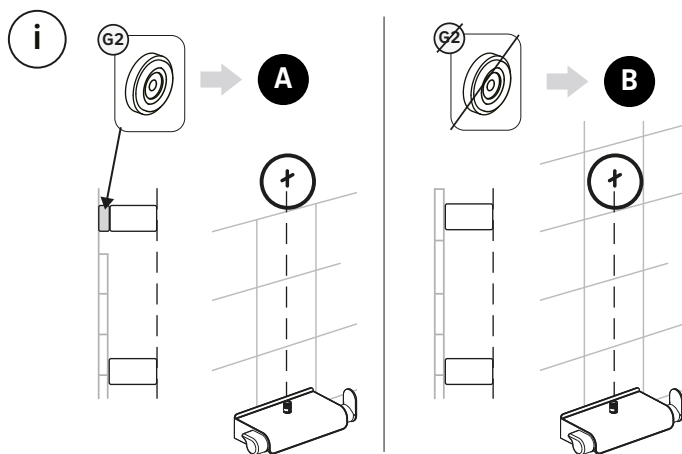

A

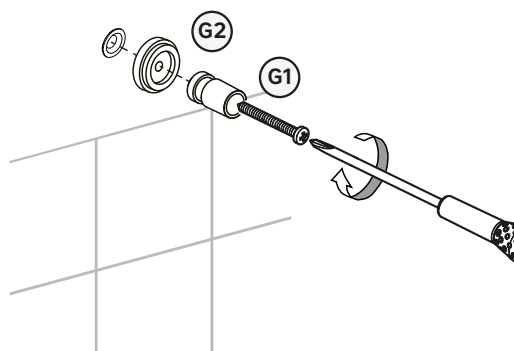

B

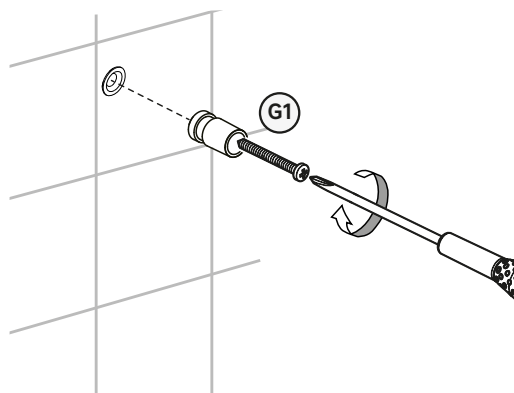

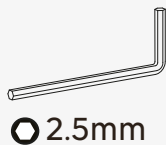

2.5mm

G3

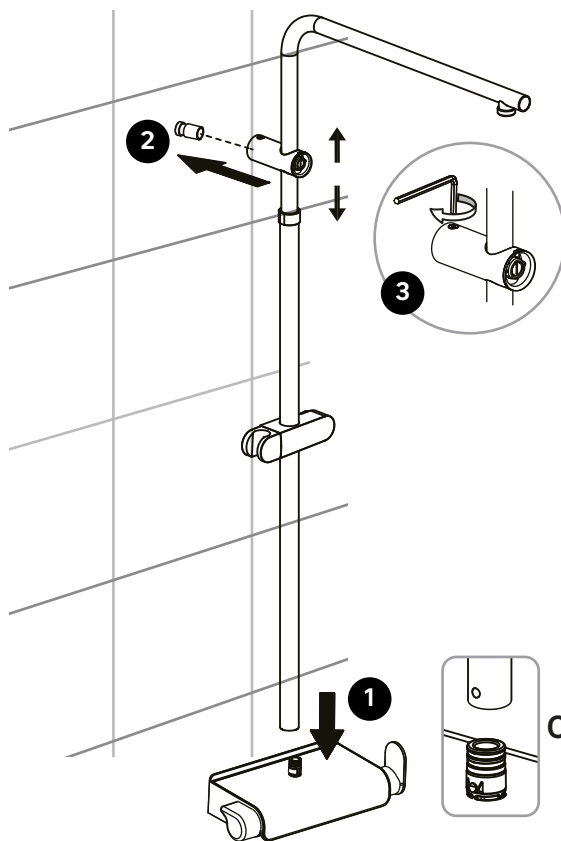
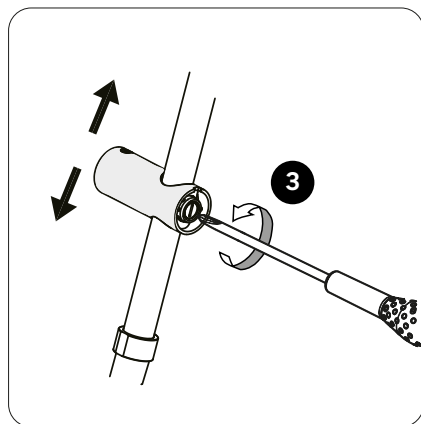
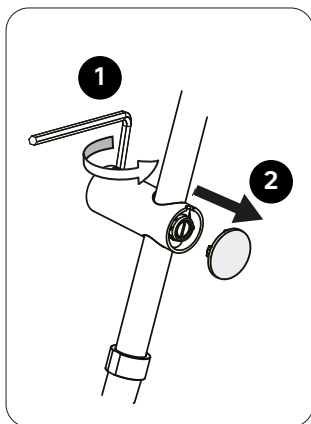

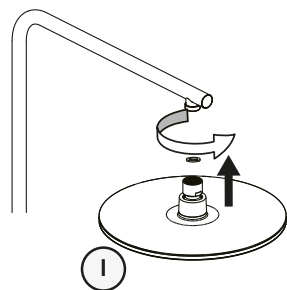
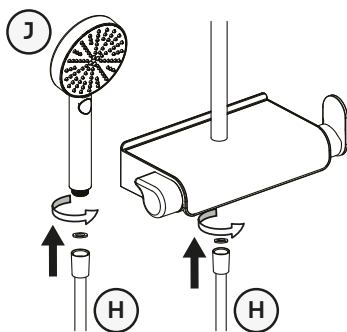
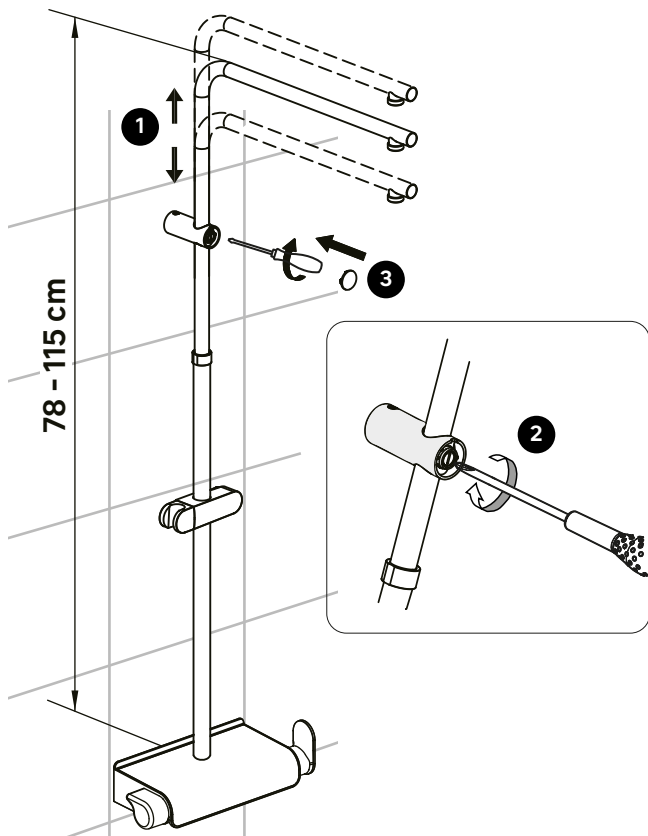
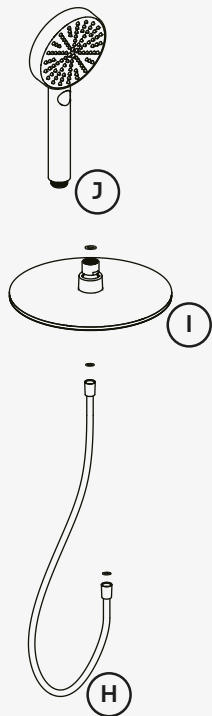

# 03

FR Utilisation  
ES Utilización  
PT Utilização  
IT Uso  
EL Χρήση

PL Użytkowanie  
UA Використання  
RO Utilizare  
BR Uso  
EN Using

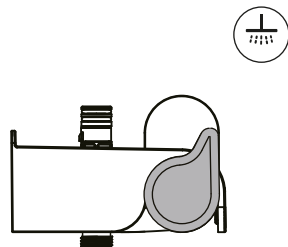
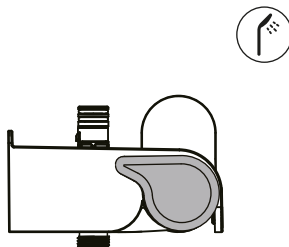
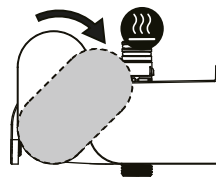
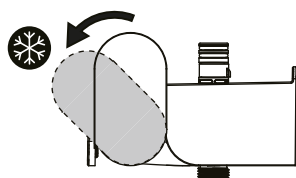
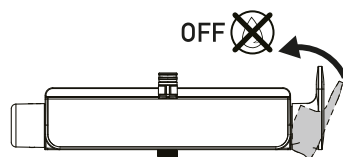
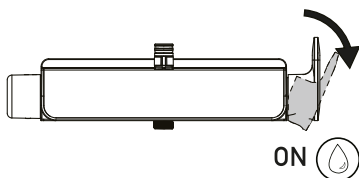
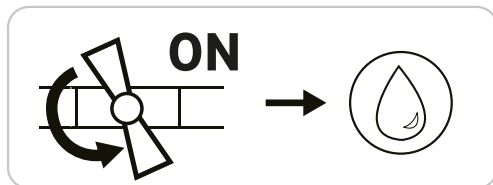

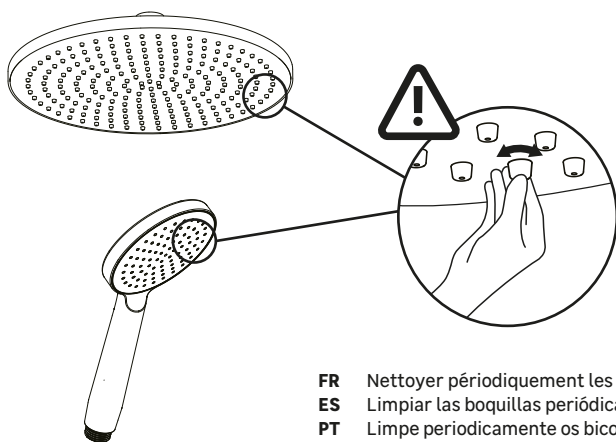
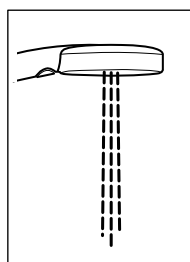
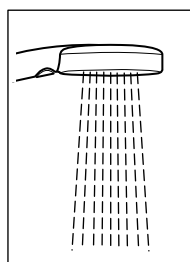
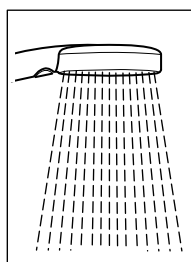
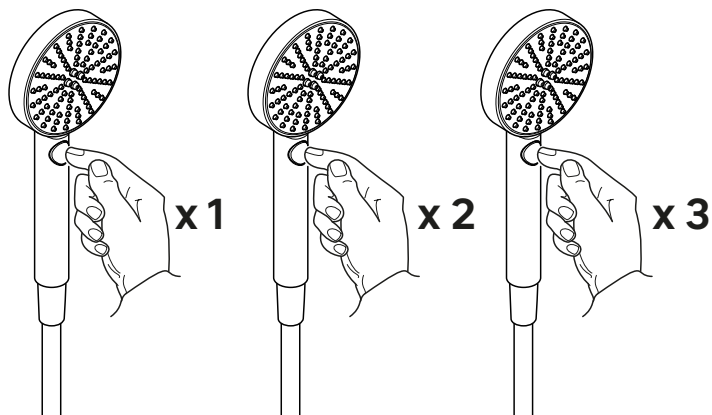

- FR** Nettoyer périodiquement les buses.
- ES** Limpiar las boquillas periódicamente.
- PT** Limpe periodicamente os bicos.
- IT** Pulire periodicamente gli ugelli.
- EL** Καθαρίζετε τα ακροφύσια τακτικά.
- PL** Okresowo czyścić dysze.
- UA** Періодично чистити насадки.
- RO** Curățați duzele periodic.
- BR** Limpe periodicamente os bicos.
- EN** Clean the nozzles periodically.

# 04

FR	Entretien	PL	Konserwacja
ES	Mantenimiento	UA	Використання
PT	Manutenção	RO	Întreținere
IT	Manutenzione	BR	Manutenção
EL	Συντήρηση	EN	Maintenance

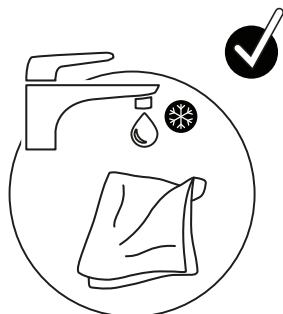

FR	Eau claire + microfibre
ES	Agua limpia + microfibra
PT	Água limpa + microfibra
IT	Acqua pulita + microfibra
EL	Καθαρό νερό + μικροφίμπρα
PL	Czysta woda + mikrofibra
UA	Чиста вода + мікрофібра
RO	Apa curată + microfibra
BR	Água limpa + microfibra
EN	Clean water + microfiber

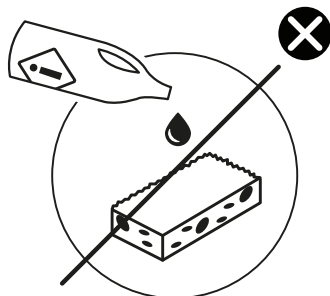

FR	Sans solvant
ES	Sin disolvente
PT	Sem solventes
IT	Senza solventi
EL	Χωρίς διαλυτικά
PL	Bez rozpuszczalnika
UA	Без розчинника
RO	Fara solvent
BR	Sem solventes
EN	Solvent-free

FR	Se référer au livret de garantie pour plus d'information.
ES	Consulte el manual de garantía para más información.
PT	Consulte o manual de garantia para mais informações.
IT	Consultare il libretto di garanzia per ulteriori informazioni.
EL	Ανατρέξτε στο φυλλάδιο της εγγύησης για περισσότερες πληροφορίες.
PL	Patrz karcie gwarancyjnej, aby uzyskać więcej informacji.
UA	Зверніться до гарантійного талону для отримання додаткової інформації.
RO	Vezi broșura de garanție pentru mai multe informații.
BR	Favor consultar o folheto de garantia para mais informações.
EN	Refer to the warranty booklet for more information.

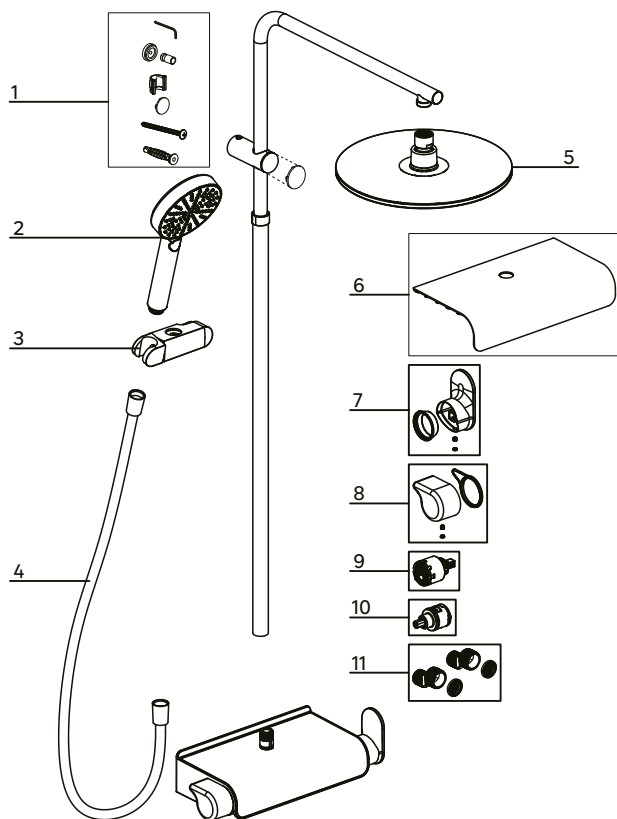

N°	DESCRIPTION	REMARKS
1	Wall bracket fixation kit+ upper cover	color declination
2	Handshower	color declination
3	Slider	color declination
4	Shower hose 150 cm	color declination
5	Shower head	color declination
6	Faucet carpet	color declination
7	Mixer handle kit	color declination
8	Diverter handle kit	color declination
9	Mixer cartridge	
10	Diverter cartridge	
11	Grid washer + Sleg kit	

**FR** Se référer au livret de garantie pour plus d'information.

**ES** Consulte el manual de garantía para más información.

**PT** Consulte o manual de garantia para mais informações.

**IT** Consultare il libretto di garanzia per ulteriori informazioni.

**EL** Ανατρέξτε στο φυλλάδιο της εγγύησης για περισσότερες πληροφορίες.

**PL** Patrz karcie gwarancyjnej, aby uzyskać więcej informacji.

**UA** Зверніться до гарантійного талону для отримання додаткової інформації.

**RO** Vezi broșura de garanție pentru mai multe informații.

**BR** Favor consultar o folheto de garantia para mais informações.

**EN** Refer to the warranty booklet for more information.

# 05

FR Changement de cartouche  
ES Cambio de cartucho  
PT Mudança de cartucho  
IT Cambio cartuccia  
EL Αλλαγή φουσιγγίου

PL Wymiana wkładu  
UA Заміна картриджа  
RO Schimbare cartuş  
BR Substituição de cartucho  
EN Replacing the cartridge

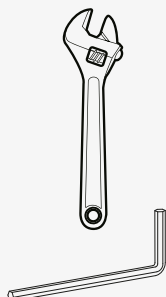
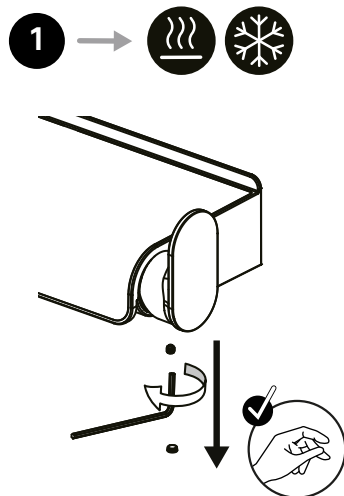
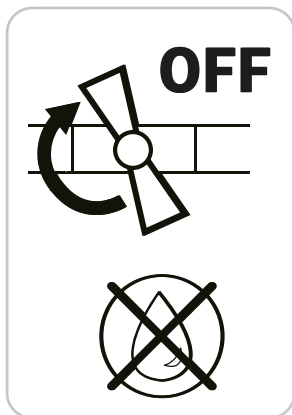

2.5mm

G3

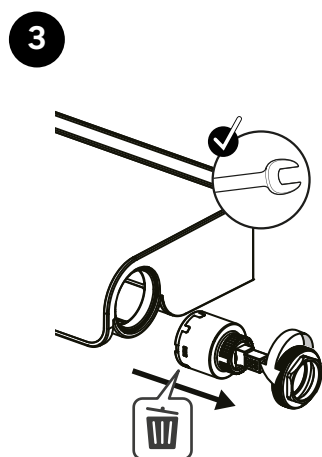
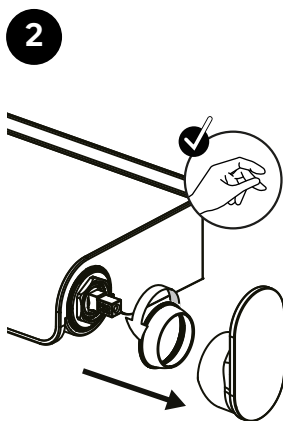



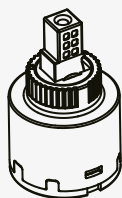

4

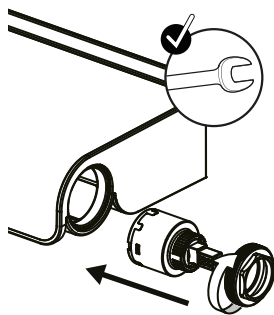

5

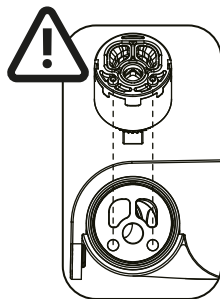
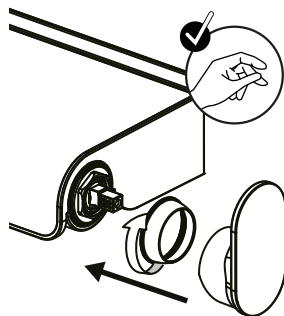

○ 2.5mm

G3

6

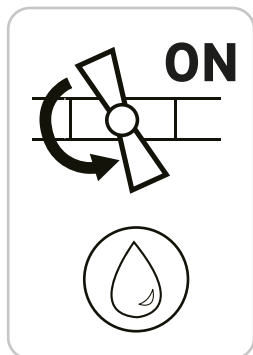
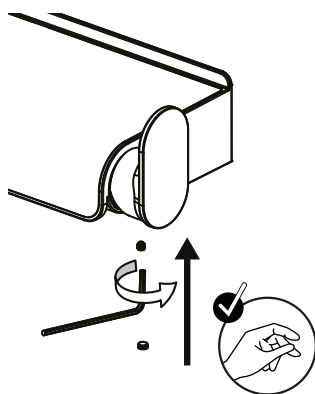

# 06

FR Changement de cartouche  
ES Cambio de cartucho  
PT Mudança de cartucho  
IT Cambio cartuccia  
EL Αλλαγή φουσιγγίου

PL Wymiana wkładu  
UA Заміна картриджа  
RO Schimbare cartuş  
BR Substituição de cartucho  
EN Replacing the cartridge

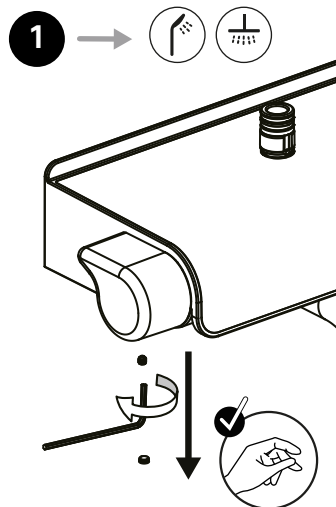
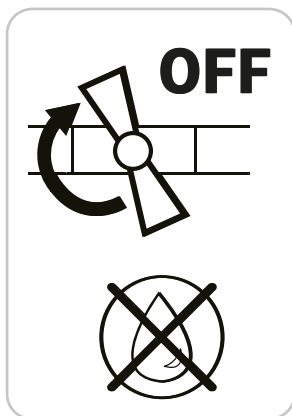

○ 2.5mm

G3

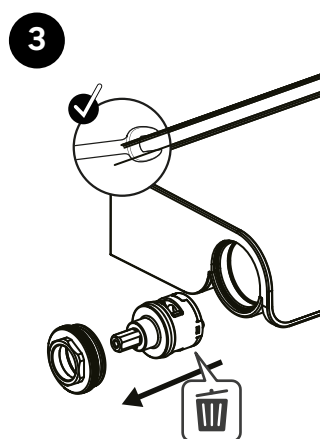
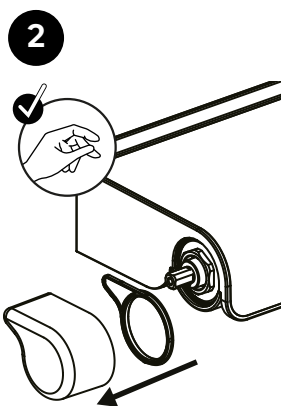

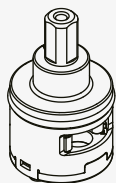

4

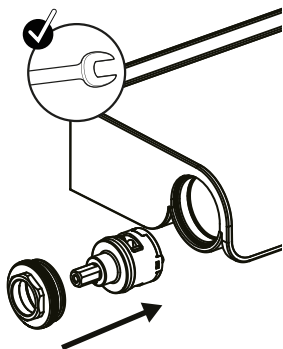

5

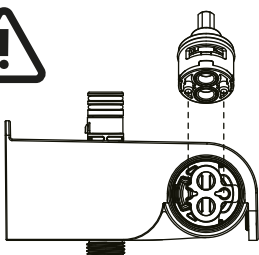
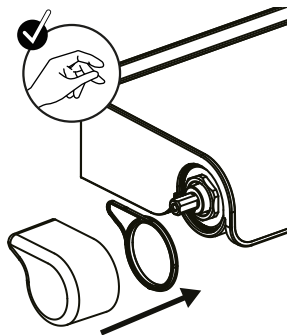

2.5mm

G3

6

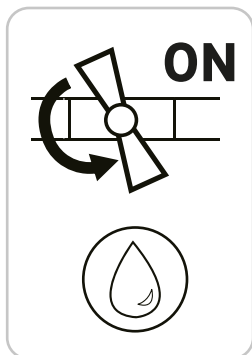
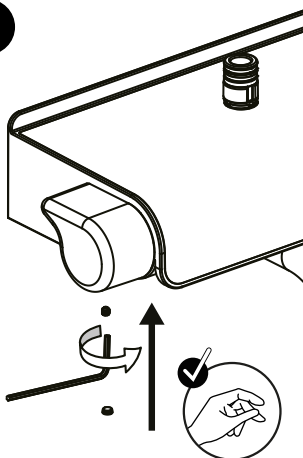

# 07

FR Changement de tapis  
ES Cambio de la alfombra  
PT Substituição do tapete  
IT Sostituzione del tappetino  
EL Αλλαγή ταπητα

PL Wymiana maty  
UA Заміна килимка  
RO Încuirea covorului  
BR Troca do tapete  
EN Changing the mat

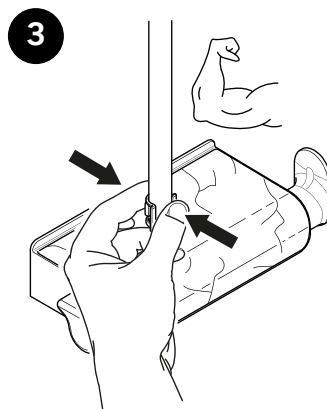
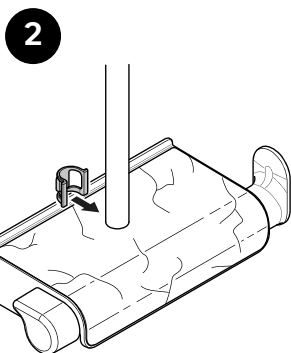
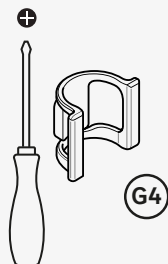
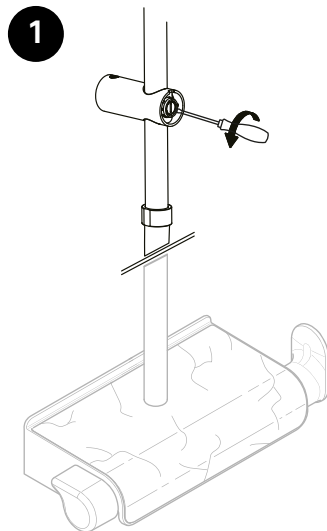
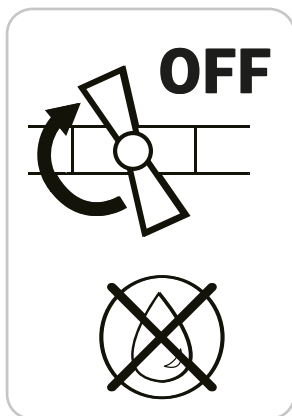

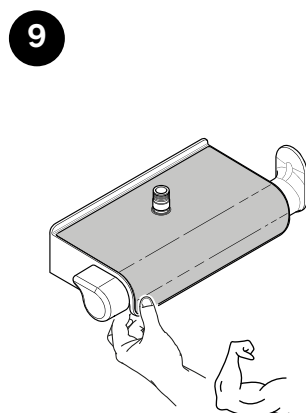
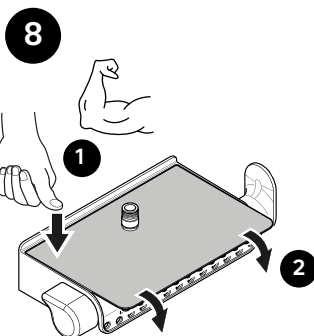
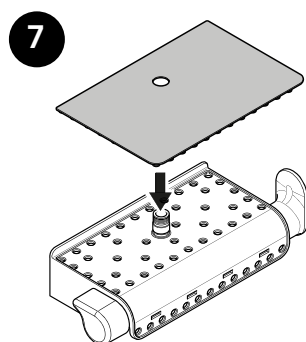
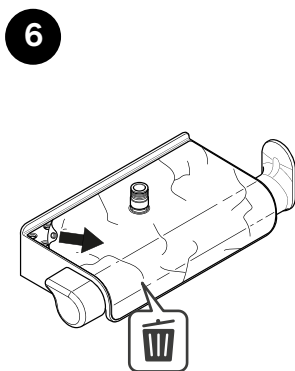
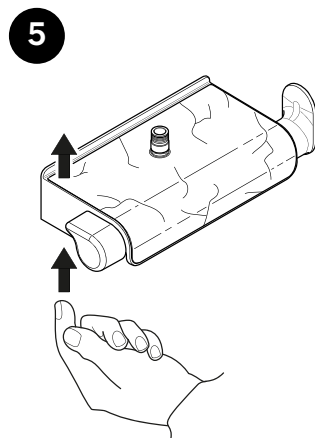
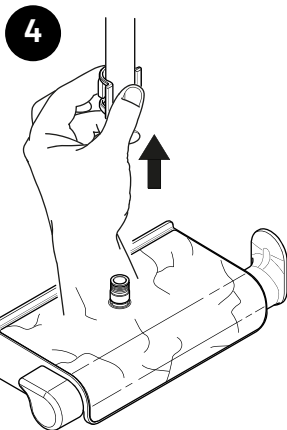
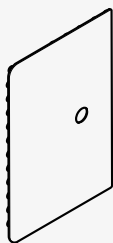



10

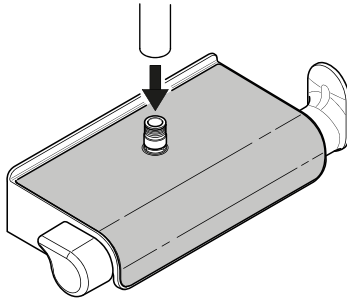

11

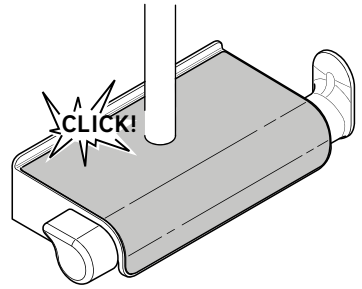

12

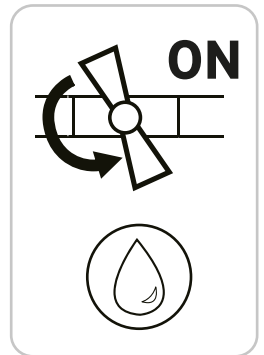
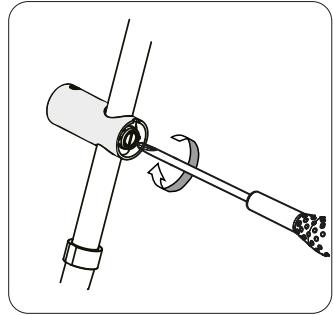
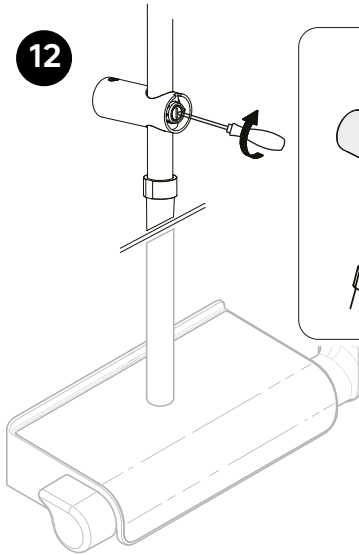





- FR** Attestation de conformité sanitaire.
- ES** Certificado de conformidad sanitaria.
- PT** Atestado de conformidade sanitária.
- IT** Attestazione di conformità sanitaria.
- EL** Βεβαίωση υγειονομικής συμμόρφωσης.
- PL** Certyfikat zgodności sanitarnej.
- UA** Декларація про відповідність санітарним нормам.
- RO** Declarația de conformitate sanitară.
- BR** Certificado de conformidade sanitária.
- EN** Declaration of sanitary conformity.



Adresses sur quefairedemesdechets.fr

Країна походження: Китай / País de Origen: China / Made in China

Garantie 10 ans / Garantía 10 años / Garantia 10 anos / Garanzia 10 anni  
/ Εγγύηση 10 ετών / Gwarancja 10 lat / Гарантія 10 років / Garanție 10  
ani / Garantia 10 anos / 10-year guarantee

**ADEO Services - 135 rue Sadi Carnot - CS 00001. 59790 RONCHIN – FRANCE**

[www.product-regulatory.adeoservices.com](http://www.product-regulatory.adeoservices.com)

Виробник: ТОВ "Адео Сервісез С.А.", вул. Саді Карно, CS 00001, 59790 Роншен, Франція.

Імпортер: ТОВ "Леруа Мерлен Україна", 04201 Україна, м.Київ, вул. Полярна 17А, +380 44 498 46 00.  
Імпортер приймає претензії від споживачів щодо товару, а також проводить його ремонт, технічне і  
гарантійне обслуговування.

Importado e distribuído por LEROY MERLIN COMPANHIA BRASILEIRA DE BRICOLAGEM CNPJ:  
01.438.784/0001-05. Rua Pascoal Pais, nº. 525, 6º andar cj 61 a 64, Vila Cordeiro, São Paulo -SP. CEP:  
04581-060

CALM (Central de Atendimento Leroy Merlin) Capitais 4020-5376 Demais Regiões 0800-0205376

Imported by Adeo South Africa (PTY) LTD T/A Leroy Merlin,  
Hosted in Leroy Merlin Fourways Store 35 Roos Street, Witkoppen Ext 97, Sandton, 2191 Johannesburg,  
Gauteng, South Africa. Tel: +27 10 493 8000 Email: [contact@leroymerlin.co.za](mailto:contact@leroymerlin.co.za)