



kanti

EAN : LED 20W : 3276007463934

LED 30W : 3276007463972

LED 50W : 3276007464023

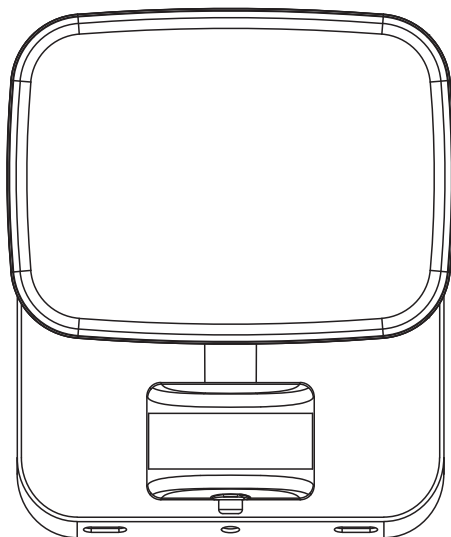

2/2



2022/07-V01

FR Manuel d'Instructions

EL Εγχειρίδιο Οδηγών

DE Anleitung Handbuch

ES Manual de Instrucciones

PL Instrukcja Obsługi

EN Instructions Manual

PT Manual de Instruções

UA Інструкція з Експлуатації

IT Manuale di Istruzioni

RO Manual de Instrucțiuni

*Année de garantie / años de garantía / Ano de garantia / Anno di garanzia / Έτος εγγύησης / Rok gwarancji / Гарантіяроків / Anul de garanție / Jahr der Garantie / Year of guarantee

** réparable / reparabile / reparável / riparabile / διορθώσιμος / naprawiany / ремонтний / reparabil / reparaturfähig / repairable



FR:Montage / ES:Montaje / PT:Montagem / IT:Montaggio / EL:Συναρμολόγηση /
PL:Montaż / UA:Збірка / RO:Montaj / DE:Montage / EN:Assembly



4 → 6



FR:Utilisation / ES:Utilización / PT:Utilização / IT:Uso / EL:Χρήση / PL:Użytkowanie /
UA:Використання / RO:Utilizare / DE:Verwenden Sie / EN:Use



7 → 10



FR:module LED dans la lampe peuvent être remplacés / ES:módulo LED de la lámpara se pueden
cambiar / PT:módulo LED podem ser substituídas / IT:módulo LED all'interno della lampada
possono essere sostituiti / EL:LED στη λυχνία μπορούν να αντικατασταθούν / PL:moduł LED w
lampie mogą być wymieniane / UA:світлодіодну панель лампи можна заміняти / RO:Modulul
LED din lampă poate fi înlocuit / DE:LED-Modul in Leuchte austauschbar / EN:The sensor and LED
module in lamp can be replaced



11

FR : CARACTERISTIQUES TECHNIQUES / ES : CARACTERÍSTICAS TÉCNICAS / PT : CARACTERÍSTICAS TÉCNICAS /
IT : CARATTERISTICHE TECNICHE / EL : ΤΕΧΝΙΚΑ ΧΑΡΑΚΤΗΡΙΣΤΙΚΑ / PL : DANE TECHNICZNE / UA : ΤΕΧΝΙΣΤΗ
ΧΑΡΑΚΤΗΡΙΚΗ / RO : CARACTERISTI TECHICE / DE : TECHNISCHE MERKMALE / EN : TECHNICAL CHARACTERISTICS



1 / 2



1



2



6



7

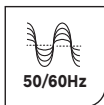

8

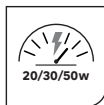

9



10



12

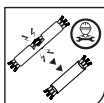

14

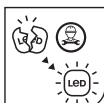

19



26



30



33



36

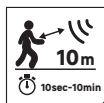

10sec-10min



180°



LED

- FR** Ce produit contient une source lumineuse de classe d'efficacité énergétique D .
- ES** Este producto contiene una bombilla de clase de eficiencia D .
- PT** Este produto contém uma fonte de luz de eficiência energética de classe D .
- IT** Questo prodotto contiene una sorgente luminosa di classe di efficienza energetica D .
- EL** Αυτό το προϊόν περιέχει πηγή φωτός κατηγορίας ενεργειακής απόδοσης D .
- PL** Niniejszy produkt zawiera źródło światła klasy efektywności energetycznej D .
- UA** Данне изделие содержит источник света класса энергоэффективности D .
- RO** Acest produs con ine o sursă de lumină din clasa de eficien ă energetică D .
- DE** Dieses Produkt enthält eine Leuchte der Energieeffizienzklasse D .
- EN** This product includes a light of the energy efficiency class D .

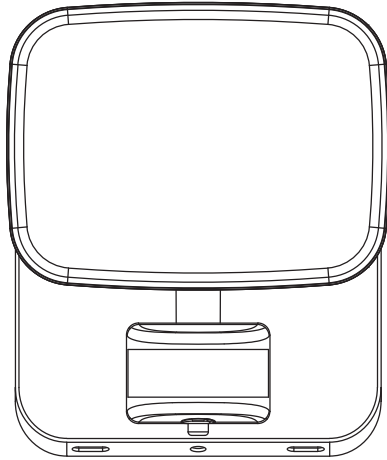

*



*Utiliser les vis et chevilles adaptées à votre support - Utilice tornillos y tacos adecuados para el soporte - Utilize buchas e parafusos adaptados à superfície de instalação - Utilizzare viti e tasselli adeguati al proprio supporto - Χρησιμοποιήστε τις κατάλληλες βίδες και ούλα για τον τοίχο σας - Используйте шурупы / крепления, которые подходят к основанию, к которому они будут крепиться - Використовуйте гвинти та штифти, що підходять для поверхні, на яку Ви монтуєте ролет/жалюзі - Należy korzystać ze śrub i kółków przystosowanych do nośnika - Utilizați șuruburile și diblurile adecvate suportului dvs - Use screws and dowels suited to your backing.



Ø8mm

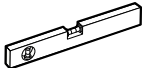

SL

N*1 → 3mm



PZ

N*2 → 3mm & 5mm



A



x2

B



x2

C



x2

A: st5x40mm

B: Ø8x40mm

C: Ø16-Ø5mm

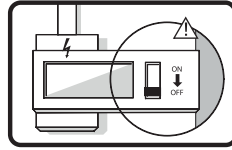

1

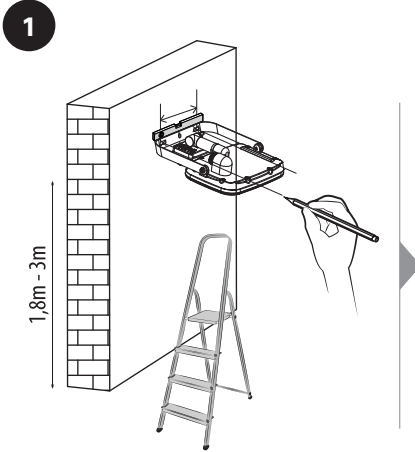

2

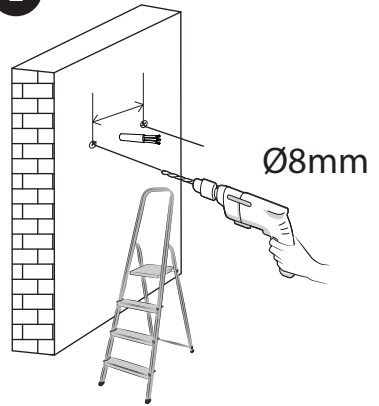

3

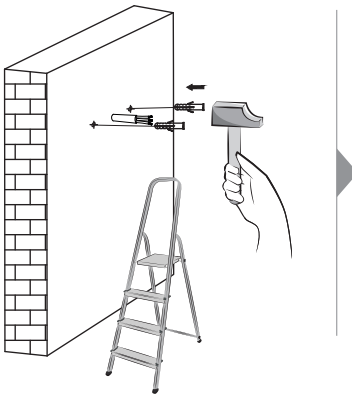

4

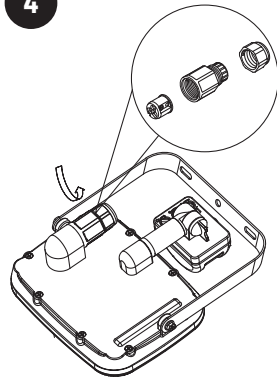

2

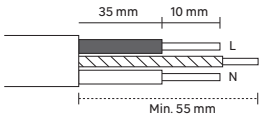
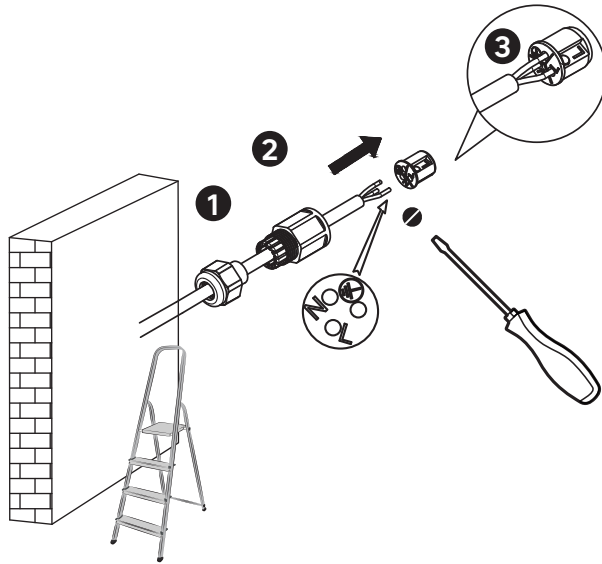

N =Bleu/Azul/Azul/Blu/Μπλε/Niebieski/Синій/Albastru/Blau/Blue

 =Vert et jaune/Verde y amarillo/Verde e amarelo/Verde e giallo/Πράσινο και κίτρινο / Zielony i żółty /Зелений і жовтий/Verde-galben/Grün und gelb/Green and yellow

L =Marron/Marrón/Castanho/Marrone/Καφέ/Brazowy/Коричневий/Maro/Braun/Brown

3

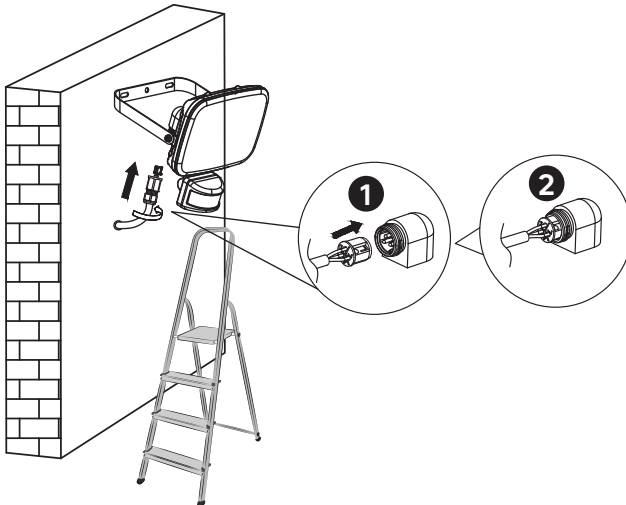

4

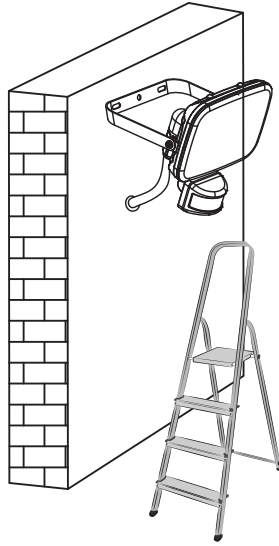

5

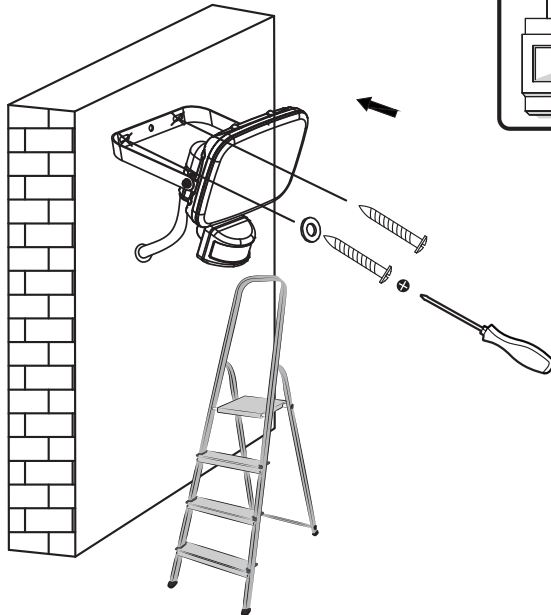

6



1

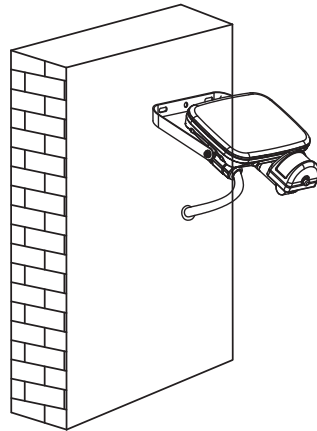
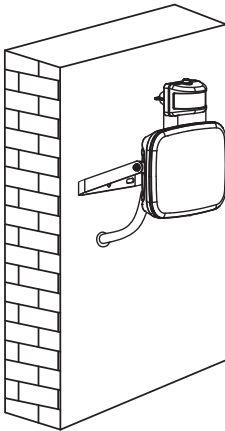
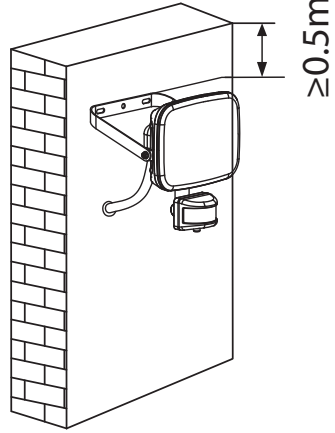
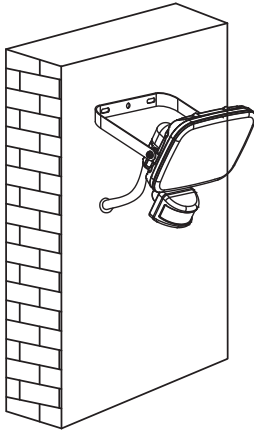

EAN CODE	3276007463934	3276007463972	3276007464023
Rated wattage	20W	30W	50W
Power factor	0.957	0.995	0.993
Supply current	0.092A	0.133A	0.221A

2

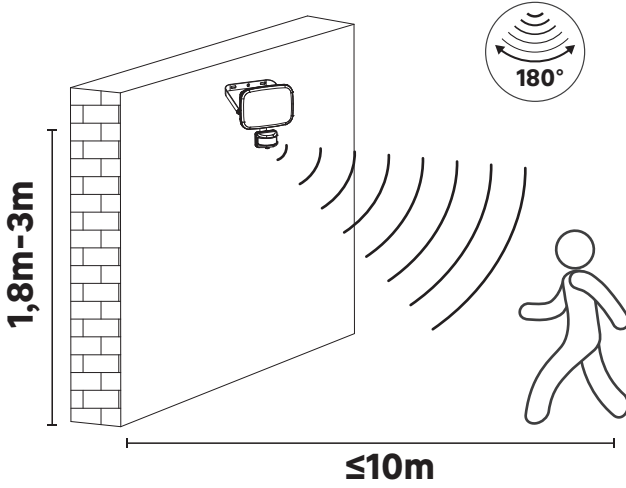

3

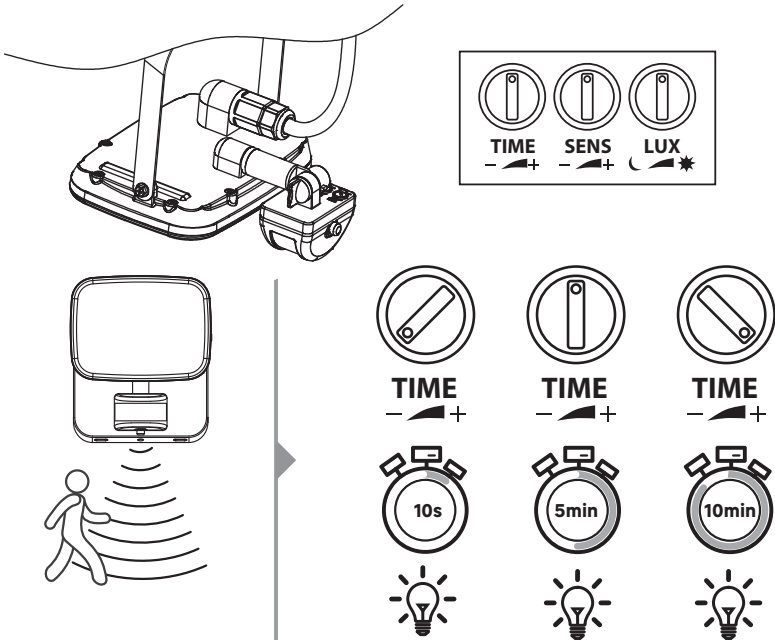

4

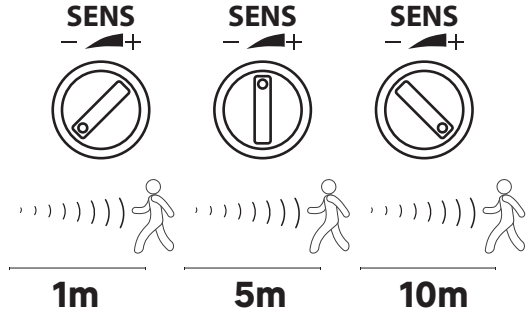
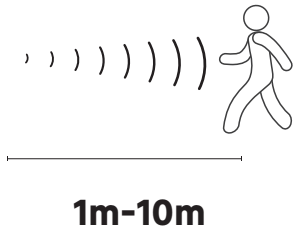
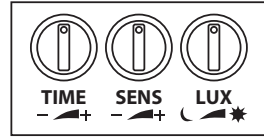
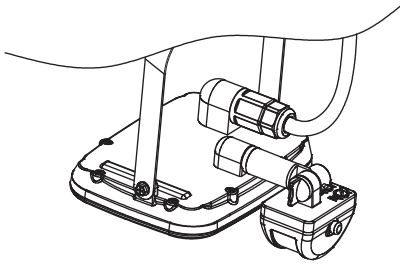

5

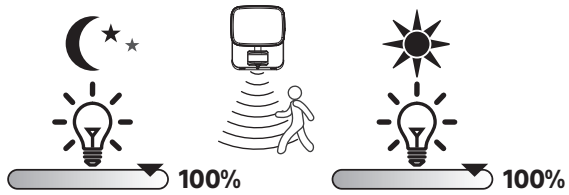
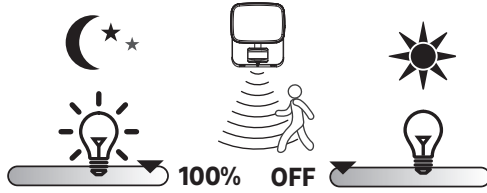
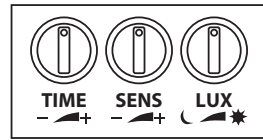
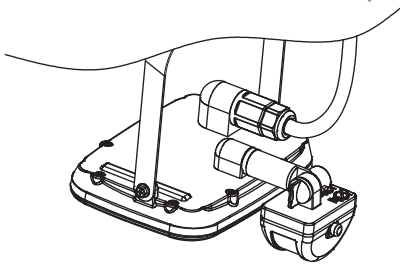

6

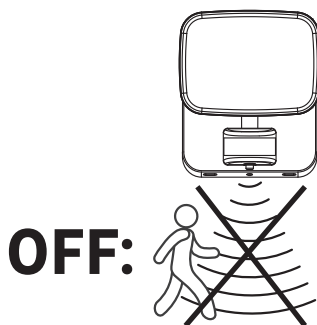
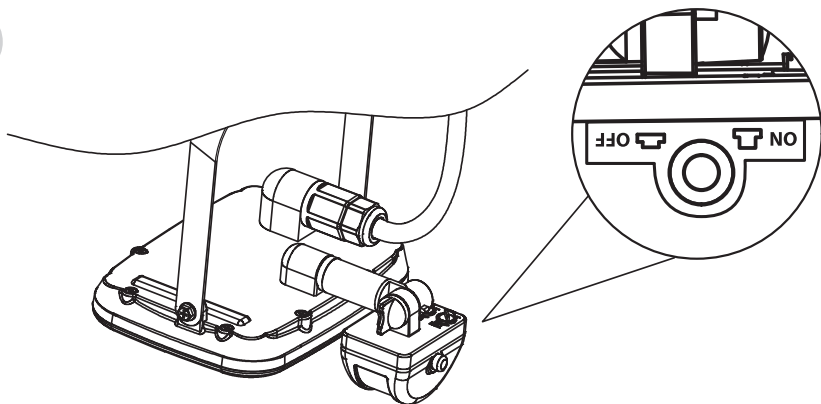

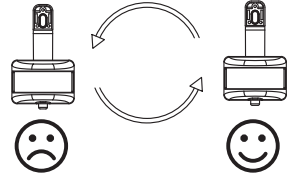
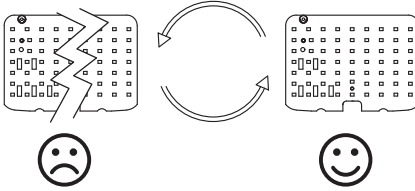

1

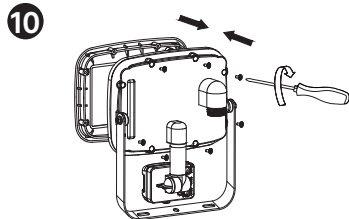
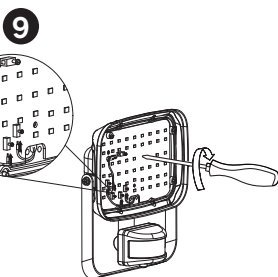
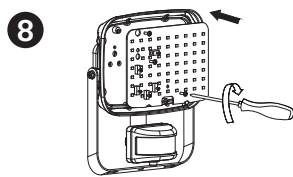
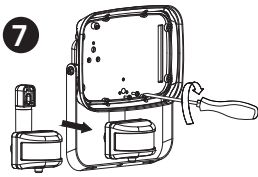
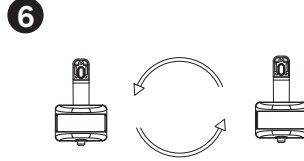
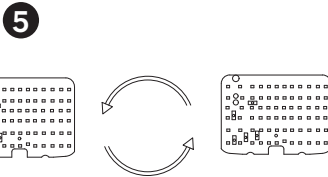
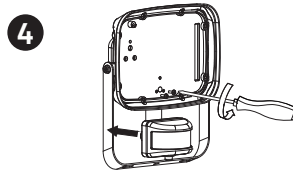
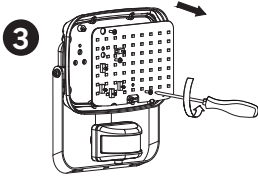
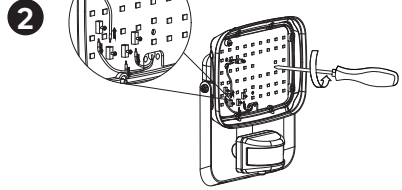
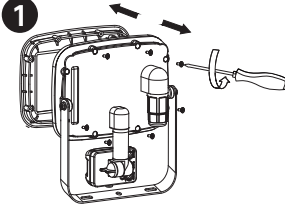



Ce produit se recycle,
s'il n'est plus utilisable
déposez-le en déchèterie.

Notice à trier.

Pour en savoir plus :
www.quefairedemesdechets.fr

- FR** Ce produit est recyclable. S'il ne peut plus être utilisé, veuillez l'apporter dans un centre de recyclage de déchets.
- ES** Este producto es reciclable. Si ya no se puede usar, llévalo a un centro de reciclaje de residuos.
- PT** Este produto é reciclável. Se deixar de o utilizar, entregue-o num centro de reciclagem de resíduos.
- IT** Questo prodotto può essere riciclato. Se deve essere smaltito, portalo presso un centro di riciclaggio.
- EL** Αυτό το προϊόν είναι ανακυκλώσιμο. Εάν δεν μπορεί πλέον να χρησιμοποιηθεί, μεταφέρετε την σε κάποιο κέντρο ανακύκλωσης απορριμμάτων.
- PL** Ten produkt poddawany jest recyklingowi, kiedy przestaje być użyteczny należy dostarczyć go do punktu zbiórki odpadów.
- UA** Цей продукт може перероблятися. Якщо воно більше не є придатне для використання, здайте його в утилізаційний центр.
- RO** Acest produs este reciclabil. Dacă nu mai poate fi folosit, vă rugăm să îl aduceți într-un centru de reciclare a deșeurilor.
- DE** Dieses Produkt ist recycelbar. Wenn es nicht mehr verwendet werden kann, bringen Sie es bitte zum Wertstoffhof.
- EN** This product is recyclable. If it cannot be used anymore, please take it to waste recycling centre.



Traduction de la version originale du mode d'emploi / Traducción de las Instrucciones originales / Tradução das Instruções Originais / Traduzione delle istruzioni originali / Μετάφραση των πρωτότυπων οδηγιών / Traduczenie instrukcji oryginalnej / Переклад оригінальної інструкції / Traducerea instrucțiunilor originale / Originalanleitung / Original Instructions

ADEO Services - 135 Rue Sadi Carnot - CS 00001 - 59790 RONCHIN - France

UA Виробник: ТОВ "Адео Сервісез С.А.", вул. Саді Карно, CS 00001, 59790 Роншен, Франція.
Імпортер: ТОВ "Леруа Мерлен Україна", 04201 Україна, м.Київ, вул. Полярна 17А, +380 44 498 46 00.
Імпортер приймає претензії від споживачів щодо товару, а також проводить його ремонт, технічне і гарантійне обслуговування

BR IMPORTADO E DISTRIBUÍDO POR:
LEROY MERLIN COMPANHIA BRASILEIRA
DE BRICOLAGEM CNPJ: 01.438.784/0001-05
Rua Pascoal Pais, nº. 525, 6º andar, cj 61 a 64 -
Vila Cordeiro, São Paulo - SP CEP: 04581-060
CALM (Central de Atendimento Leroy Merlin)
Capitais 4020-5376 Demais Regiões 0800-0205376
IMAGEM ILUSTRATIVA

ZA Imported by Adeo South Africa (PTY) LTD T/A Leroy Merlin/Leroy Merlin Greenstone Store/Corner Blackrock Street and Stoneridge Drive, Greenstone Park Ext 2, Edenvale, 1610 Johannesburg, Gauteng, South Africa

Made in China
Країна походження: Китай