



552R

BOTTLE TRAP FOR KITCHEN SINK 1 1/2"

FUNCTION :

Device aimed at draining washbasins and vanity bowls & prevent odor from the waste network

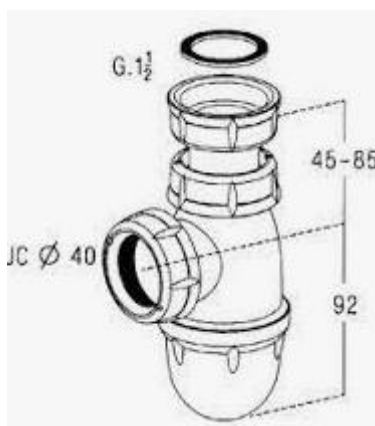

FUNCTION :

Device for a washbasin to prevent odor from the waste pipe

TECHNICAL FEATURES :

Description :

- Bottle trap, adjustable in height
- Color : Black

Materials :

- Body : **recycled polypropylene**
- Washers : EPDM

Dimensions :

- Outlet connection : 1"1/2
- Height adjustment : from 137 to 177mm
- Water seal height : 50 mm

Performance :

- Flow rate : -- l/min under 120 mm water load height

STANDARDS :

NF-EN 274

PACKAGING :

Cardboard box