



IMPORTANTE! CONSERVARE PER RIFERIMENTO FUTURO: LEGGERE ATTENTAMENTE.

IMPORTANT! KEEP FOR FUTURE REFERENCE: READ CAREFULLY.

IMPORTANT! À CONSERVER POUR CONSULTATION ULTÉRIEURE: À LIRE ATTENTIVEMENT.

WICHTIG! BITTE AUFMERKSAM DURCHLESEN UND GUT AUFBEWAHREN.

IMPORTANTE! GUARDAR PARA FUTURAS CONSULTAS: LEER ATENTAMENTE.



- Spazio necessario per assemblaggio, superficie pavimento 3m x 3m.
- Space required for assembly, floor area 3m x 3m.
- Espace requis au sol 3m x 3m.
- Platzbedarf für Aufbau Bodenfläche 3m x 3m.
- Espacio necesario para montaje, superficie de suelo 3m x 3m.



- Tempo approssimativo assemblaggio 20 minuti, 2 persone per assemblaggio.
- Approximate assembly time 20 minutes, 2 people for assembly.
- Temps de montage approximatif 20 minutes, 2 personnes.
- Ungefähre Aufbauzeit 20 Minuten, 2 Personen pro Aufbau.
- Tiempo aproximado para montaje 20 minutos, 2 personas por ensamblaje.



Valable uniquement pour la France
 Alleen geldig voor Frankrijk

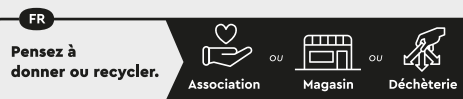

<https://quefairedemesdechets.fr>

Elenco Componenti

COMPONENT LIST
LISTE DES COMPOSANTS
KOMPONENTENLISTE
LISTA DE COMPONENTES
LISTA DE COMPONENTES

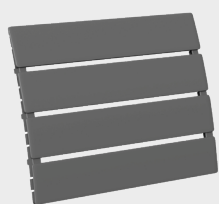

A x4



E x1



B x3

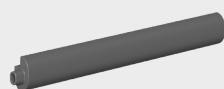

F x10



C x3



G x1



H x1

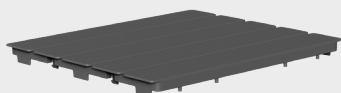

D x5

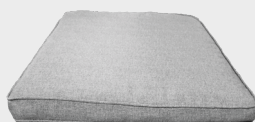

I x4



ISTRUZIONI DI MONTAGGIO PER IL DIVANO
INSTRUCTIONS D'ASSEMBLAGE POUR LE DIVAN
ASSEMBLING INSTRUCTIONS FOR THE SOFA
AUFBAU ANWEISUNGEN FUER DAS SOFA
INSTRUCCIONES DE MONTAJE PARA EL DIVAN
INSTRUÇÕES DE MONTAGEM POR O SOFÀ

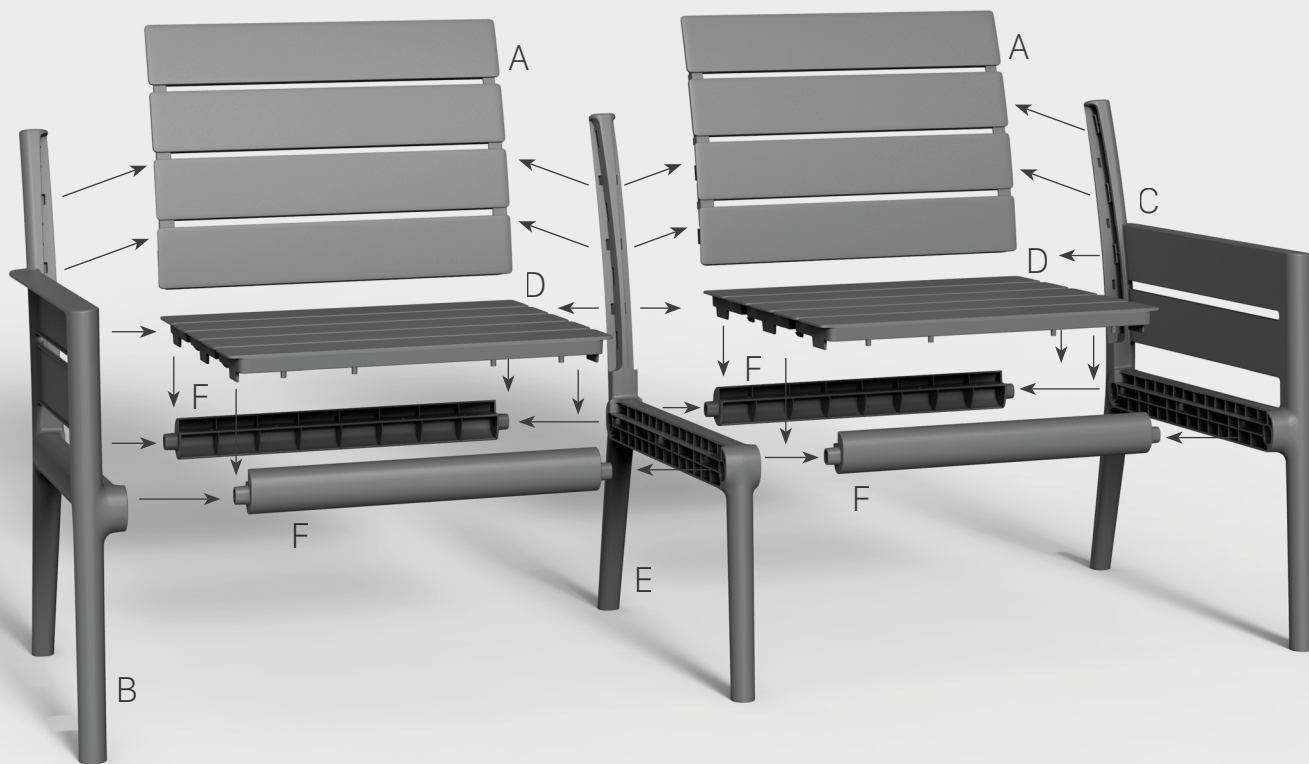



ISTRUZIONI DI MONTAGGIO PER 1 POLTRONA
INSTRUCTIONS D'ASSEMBLAGE POUR 1 FAUTEUIL
ASSEMBLING INSTRUCTIONS FOR 1 ARMCHAIR
AUFBAU ANWEISUNGEN FUER 1 SESSEL
INSTRUCCIONES DE MONTAJE PARA 1 SILLON
AUFBAU ANWEISUNGEN FUER 1 SESSEL

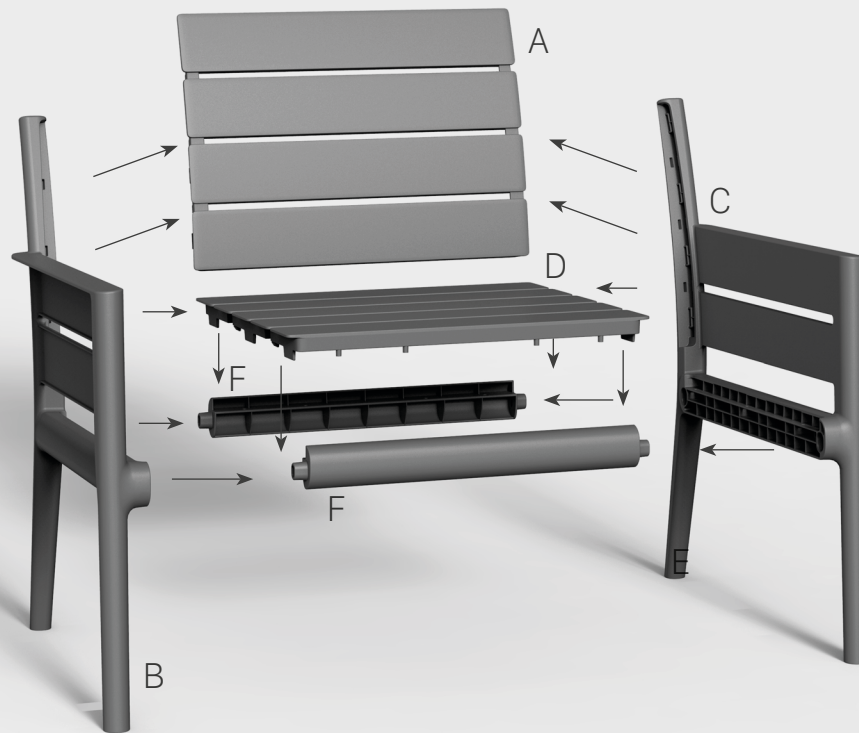



ISTRUZIONI DI MONTAGGIO PER IL TAVOLINO
INSTRUCTIONS D'ASSEMBLAGE POUR LA TABLE
ASSEMBLING INSTRUCTIONS FOR THE TABLE
AUFBAU ANWEISUNGEN FUER DEN TISCH
INSTRUCCIONES DE MONTAJE PARA LA MESA
INSTRUÇÕES DE MONTAGEM POR LA MESA BAIXA

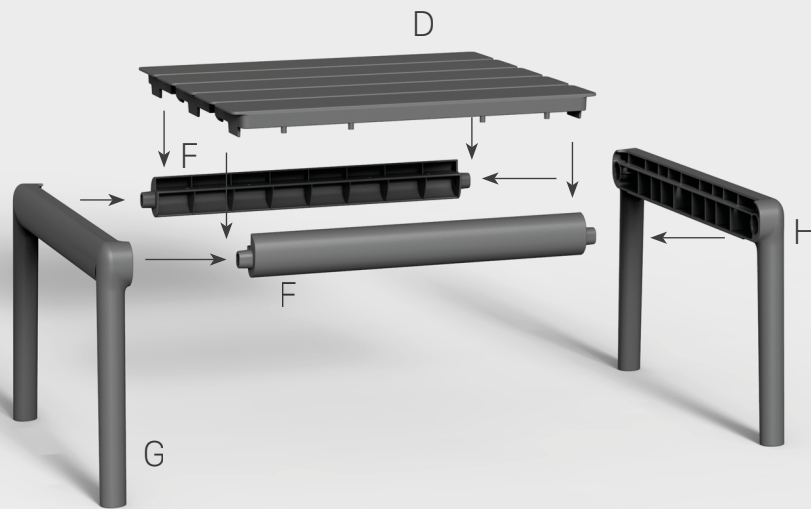

I

Prodotto in plastica

NON ESPORRE a + 50°C e - 0°

Usare su una superficie piana.

Pulire con acqua e sapone, **NON USARE SOLVENTI****GB**

Plastic product

DO NOT EXPOSE to + 50°C and - 0°

Use on a level surface.

Clean using soap and water, **DO NOT USE SOLVENTS****F**

Produit en plastique

NE PAS EXPOSER à + 50°C et à - 0°C

A utiliser sur un support plan.

Nettoyer avec eau et savon, **NE PAS UTILISER DE SOLVANTS****D**

Kunststoffprodukt

KEINER TEMPERATUR AUSSETZEN, die über 50°C oder unter -0°C liegt

Auf einer ebenen Oberfläche verwenden.

Nur mit Wasser und Seife reinigen,

KEINE LÖSUNGSMITTEL VERWENDEN.**E**

Producto de plástico

NO EXPONGA a + 50°C y - 0°

Use sobre una superficie plana.

Limpie con agua y jabón, **NO USE SOLVENTES****PT**

Produto de plástico

NÃO EXPOR a + 50°C e - 0°

Usar sobre uma superfície plana.

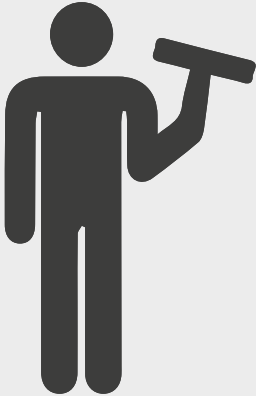
Limpar com água e sabão, **NÃO USAR SOLVENTES**

- Pulire con acqua e detersivo liquido o cremoso evitando prodotti abrasivi. Risciacquare bene e asciugare.
- Clean with water and liquid or creamy detergent avoiding abrasive products. Rinse well and dry.
- Nettoyer avec de l'eau et un détergent liquide ou crémeux en évitant les produits abrasifs. Bien rincer et sécher.
- Mit Wasser und flüssigem oder cremigem Reinigungsmittel reinigen. Scheuermittel vermeiden. Gut abspülen und trocknen.
- Limpiar con agua y detergente líquido o cremoso evitando productos abrasivos. Enjuague bien y seque.
- Limpe com água e detergente líquido ou cremoso evitando produtos abrasivos. Enxágüe bem e ary.

**ATTENZIONE**

Lavare le federe soltanto a mano ed in acqua fredda

ATTENTION

Laver les housses à la main et à l'eau froide seulement

ATTENTION

Hand wash the covers with cold water only

ACHTUNG

Kissenbezüge nur von Hand in kaltem Wasser waschen.

ATENCIÓN

Lavar las fundas a mano en agua fría

ATENÇÃO

Lavar as capas das almofadas à mão em água fria

**Prodotto da IGAP spa**

di Cogozzo di Viadana nello stabilimento di - 46013 Canneto S/O (MN) Via Garibaldi 244

Tel. +39 0376 7172200 - Fax +39 0376 7172290