

EAN : 3276007715507
3276007715521
Ref : LAC-CF582028-10
LAC-CF582128-11

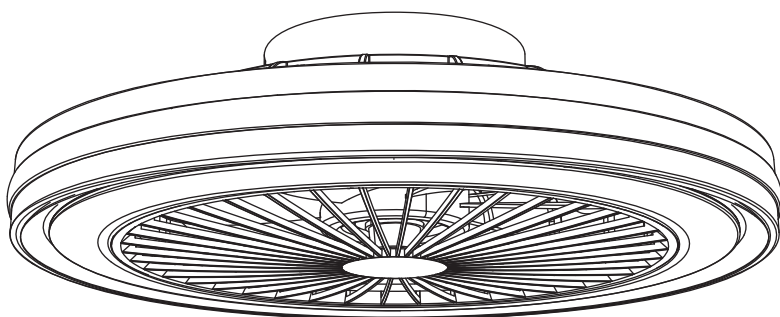

2/2



2023-08-V00

FR Manuel d'Instructions

ES Manual de Instrucciones

PT Manual de Instruções

IT Manuale di Istruzioni

EL Εγχειρίδιο Οδηγιών

PL Instrukcja Obsługi

UA Інструкція з Експлуатації

RO Manual de Instrucțiuni

BR Manual de Instrução

DE Anleitung Handbuch

EN Instructions Manual

*Année de garantie / años de garantía / Ano de garantia / Anno di garanzia / Έτος εγγύησης / Rok gwarancji / Гарантіяроків / Anul de garanție / Anos de garantía / Jahr der Garantie / Year of guarantee

** réparable / reparabile / reparável / riparabile / διορθώσιμος / naprawiany / ремонтний / reparabil / reparaturfähig / reparável / repairable



FR: Montage / ES: Montaje / PT: Montagem / IT: Montaggio / EL: Συναρμολόγηση / PL: Montaż / UA: Збірка / RO: Montaj / BR: Montagem / DE: Montage / EN: Assembly



FR: Utilisation / ES: Utilización / PT: Utilização / IT: Uso / EL: Χρήση / PL: Użytkowanie / UA: Використання / RO: Utilizare / BR: Utilização / DE: Verwenden Sie / EN: Use







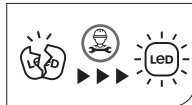
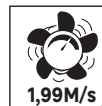
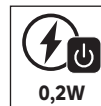
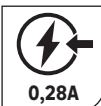
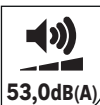
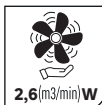
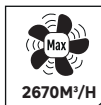
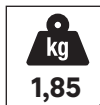
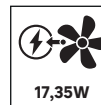
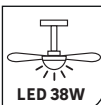
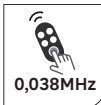
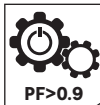
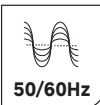
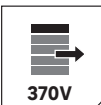
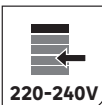

FR: Nettoyage / ES: Limpieza / PT: Limpeza / IT: Pulizia / EL: Καθάρισμα / PL: Czyszczenie / UA: Чищення / RO: Curățare / BR: Limpeza / DE: Reinigung / EN: Cleaning

FR: CARACTÉRISTIQUES TECHNIQUES / ES: CARACTERÍSTICAS TÉCNICAS / PT: CARACTERÍSTICAS TÉCNICAS / IT: CARATTERISTICHE TECNICHE / EL: ΤΕΧΝΙΚΑ ΧΑΡΑΚΤΗΡΙΣΤΙΚΑ / PL: DANE TECHNICZNE / UA: ТЕХНІЧНІ ХАРАКТЕРИСТИКИ / RO: CARACTERISTICI TEHNICE / BR: CARACTERÍSTICAS TÉCNICAS / DE: TECHNISCHE CHARAKTERISTIKA / EN: TECHNICAL CHARACTERISTICS



- FR Ce produit contient une source lumineuse de classe d'efficacité énergétique D.
 ES Este producto contiene una bombilla de clase de eficiencia D.
 PT Este produto contém uma fonte de luz de eficiência energética de classe D.
 IT Questo prodotto contiene una sorgente luminosa di classe di efficienza energetica D.
 EL Αυτό το προϊόν περιέχει πηγή φωτός κατηγορίας ενεργειακής απόδοσης D.
 PL Niniejszy produkt zawiera źródło światła klasy efektywności energetycznej D.
 UA Данное изделие содержит источник света класса энергоэффективности D.
 RO Acest produs conține o sursă de lumină din clasa de eficiență energetică D.
 DE Dieses Produkt enthält ein Licht der Energieeffizienzklasse D.
 EN This product includes a light of the energy efficiency class D.
 (EU)2019/2015

	1	2	3	4	5	6
 W	4,5	5,9	7,7	10,2	13,4	17,4
 RPM	550	656	755	854	956	1056
 m3/H	1160	1290	1610	2160	2360	2670
 m3/min/W	4,3	3,7	3,5	3,5	2,9	2,5
 XXdB	35,1	38,9	43,0	46,7	50,1	53,0



A

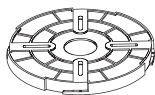

B

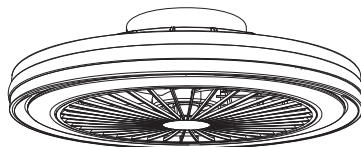

C



D



E



F



G

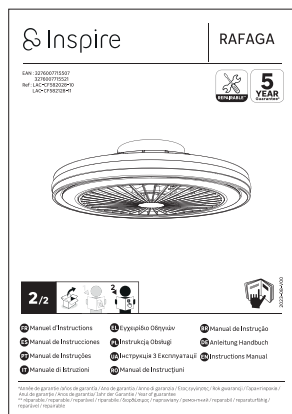

+

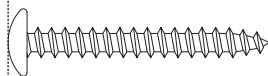

C x2

+



E x1



FR : Scanner ce code QR pour voir la vidéo de montage

ES : Escanear este código QR para ver el video de montaje

PT : Digitalize este código QR para ver o vídeo de montagem

IT : Scannerizza questo codice QR per vedere il video di montaggio

EL : Σαρώστε τον συγκεκριμένο κωδικό QR για να δείτε το βίντεο συναρμολόγησης

PL : Zeskanuj ten kod QR, aby zobaczyć wideo montażowe

UA : Відскануйте цей QR-код, щоб переглянути відео про монтаж

RO : Scațați acest cod QR pentru a viziona videoclipul de montaj

BR : Escanear este código QR para ver o vídeo de montagem

NL : Scan deze QR-code om de montagevideo te bekijken

DE : Scannen Sie diesen QR-Code, um das Montagevideo anzusehen

EN : Scan this QR code to view the assembly video

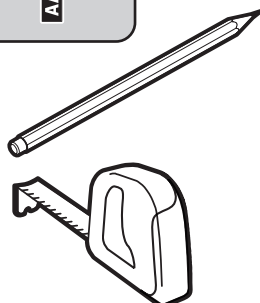
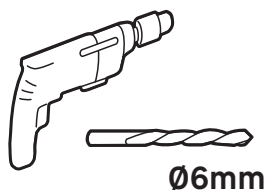
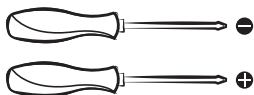

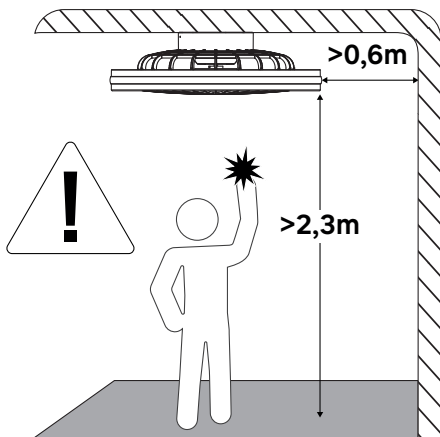
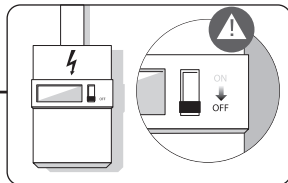
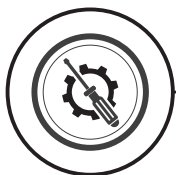

1

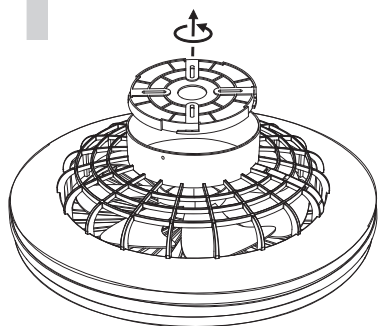

A

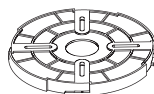

+

B

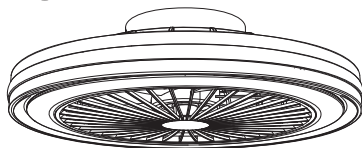

2

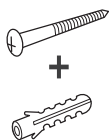
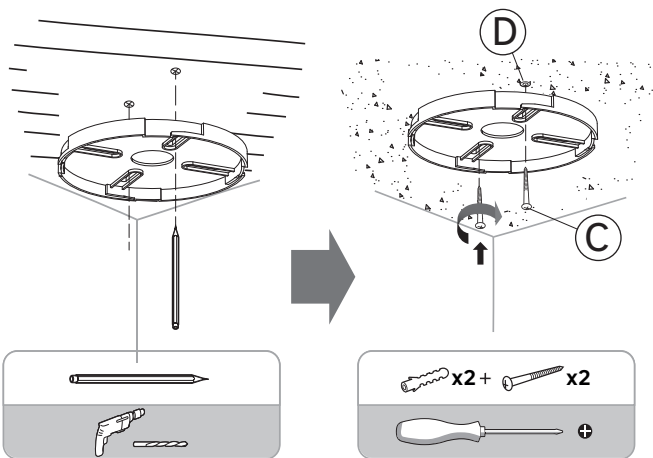

Utiliser des vis et des chevilles adaptées à votre support / Utilice tacos y tornillos adecuados al soporte / Utilize buchas e parafusos adequado ao seu suporte / Utilizzare viti e tasselli adatti per il retro / Χρησιμοποιήστε βίδες και βύσματα που ταιριάζουν στην επιφάνεια στήριξης. / Należy użyć śrub i kołków odpowiednich dla podłoża / Використовуйте гвинти та шканти, призначені для задньої поверхні. / Utilizați șuruburi și dibluri adecvate pentru suportul dvs. / Use parafusos e buchas adequados para seu suporte / Verwenden Sie für Ihre Unterlage geeignete Schrauben und Dübel / Use screws and dowels suited to your backing

3

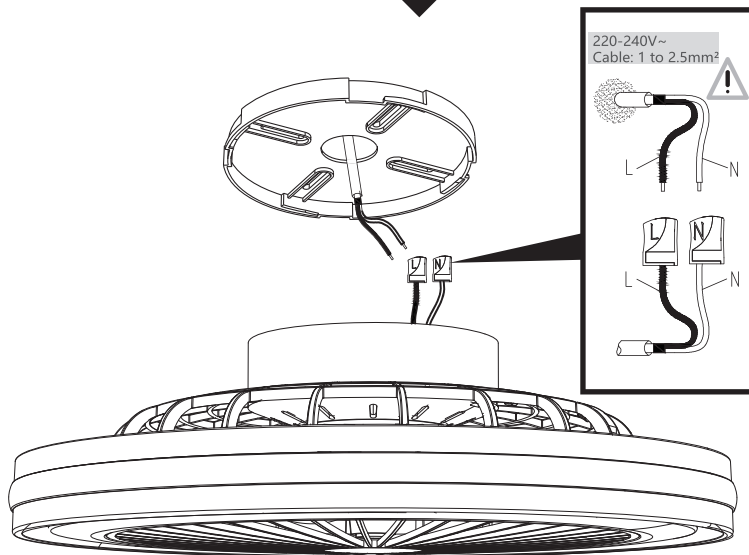

N =Bleu/Azul/Azul/Blu/Μπλε/Niebieski/Синій /Albastru/Blau/Blue

L =Marron/Marrón/Castanho/Mar rone/Καφέ/Brazowy/
Кори чневий/Μαρο/Marrom/B raun/Brown

4

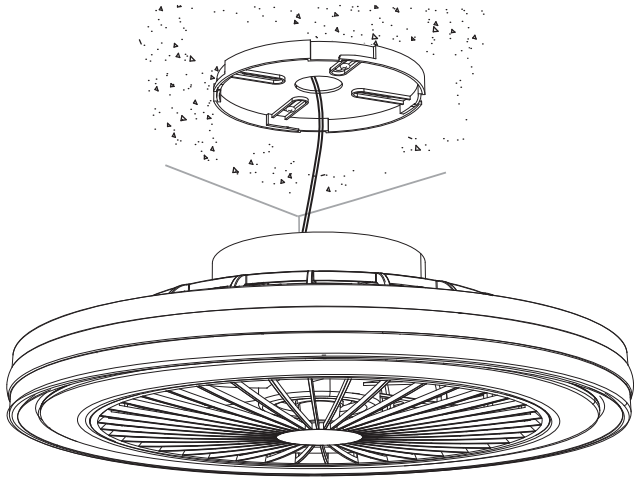

5

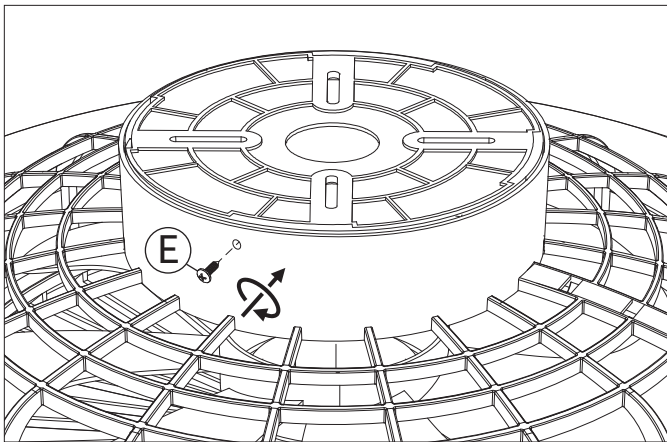

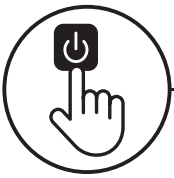

1

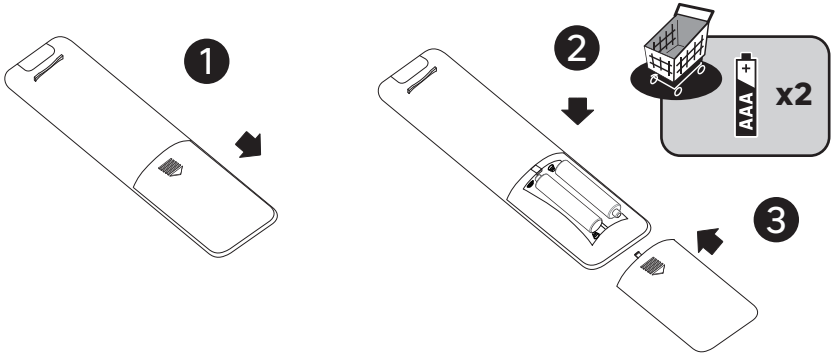
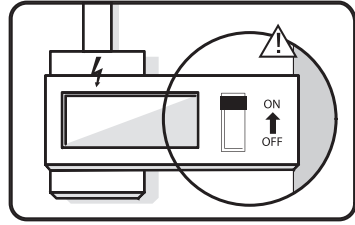

2

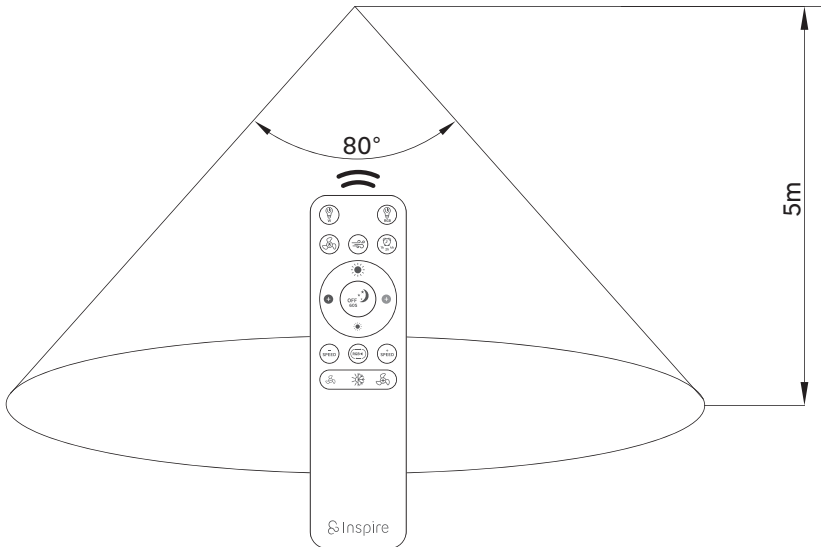

3

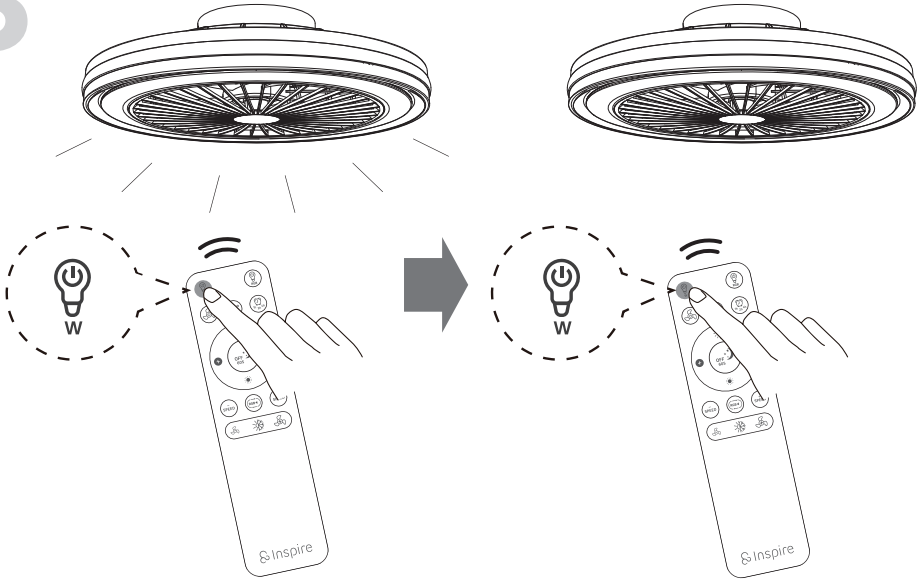

4

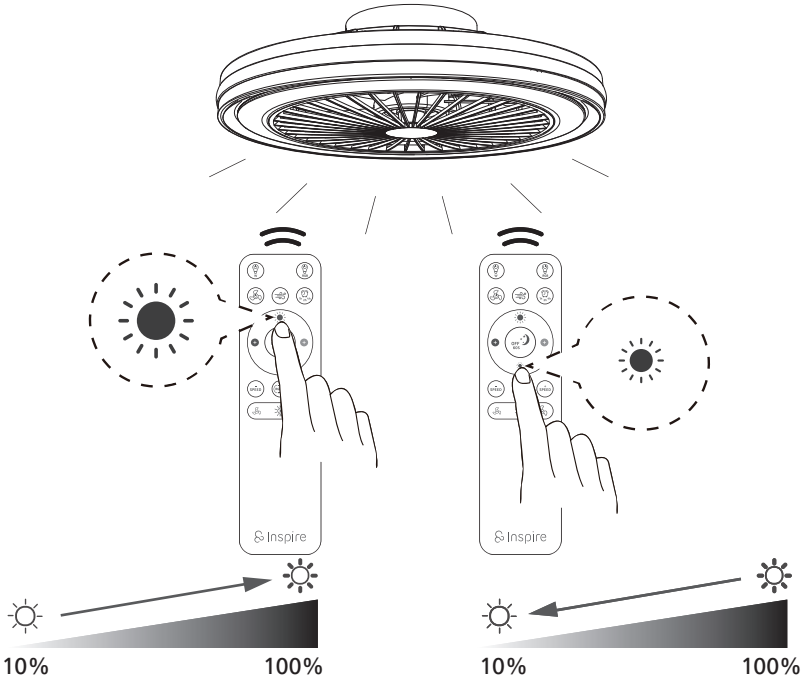

5

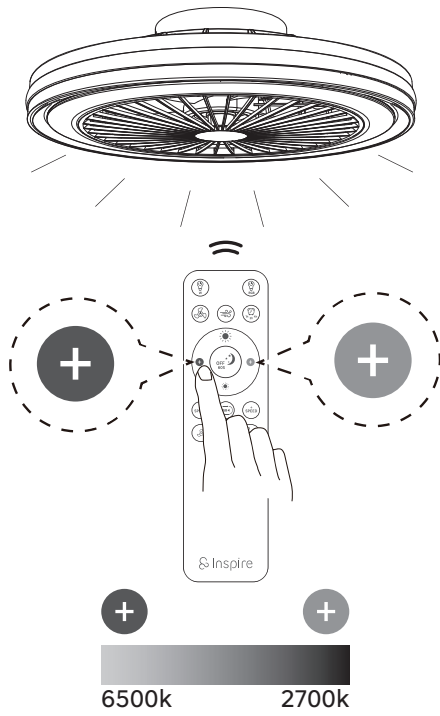

6

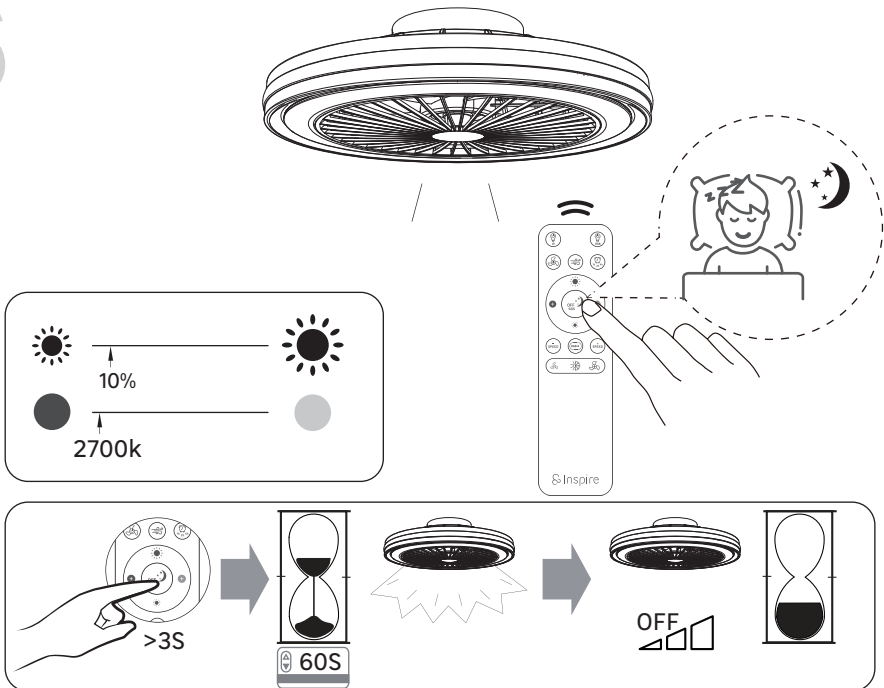

7

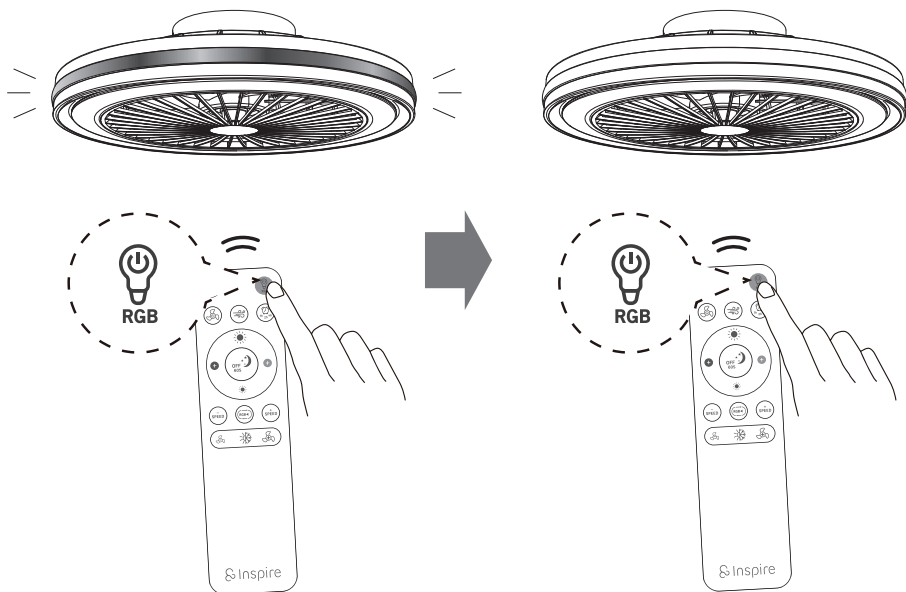

8

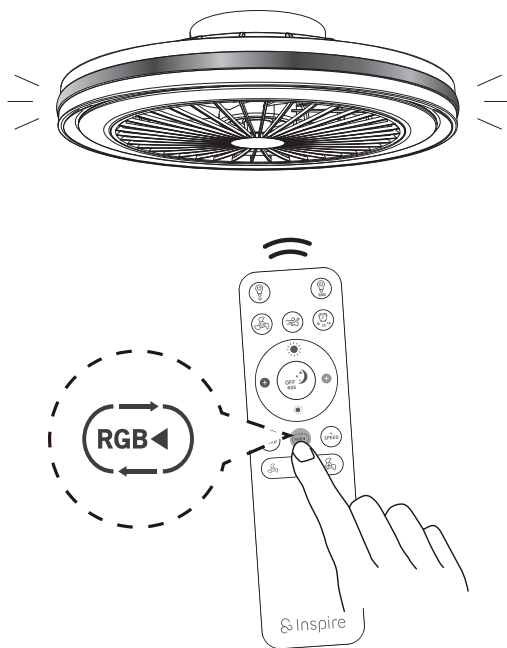

9

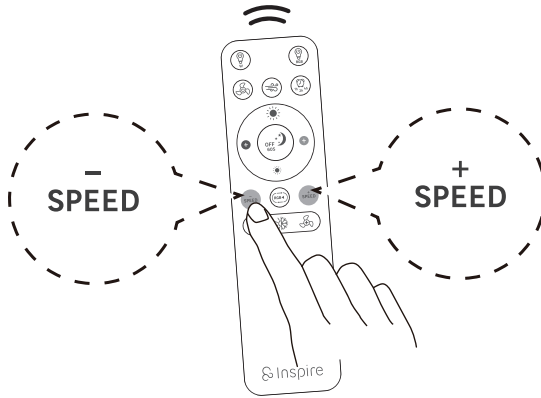
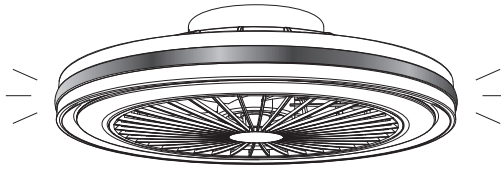

10

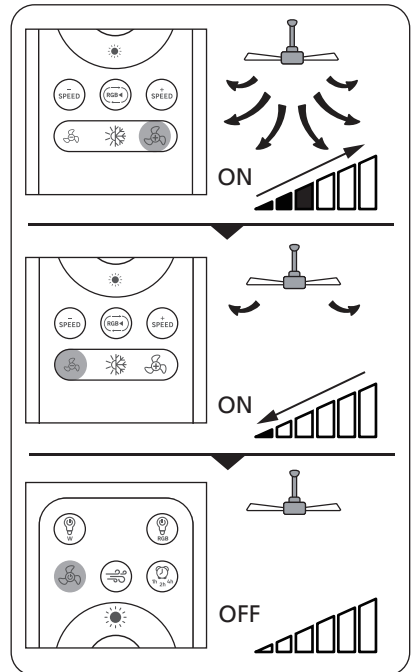
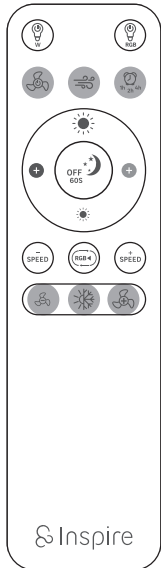
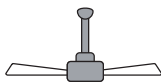

11

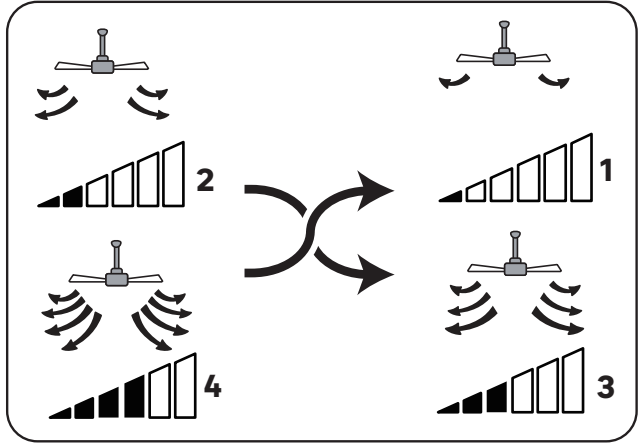
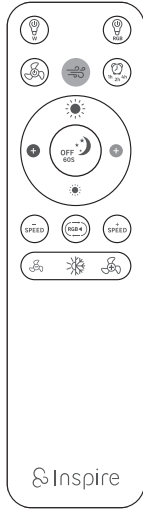

12

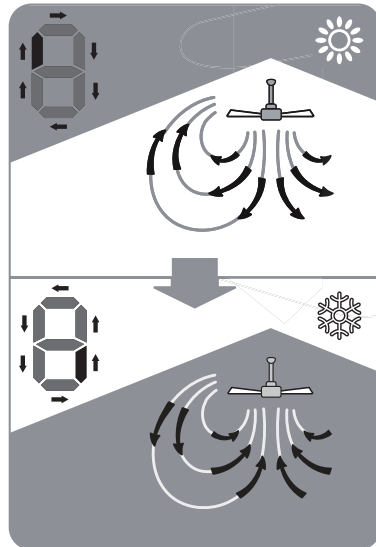
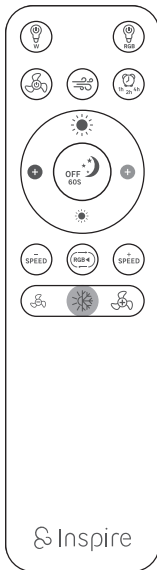

13

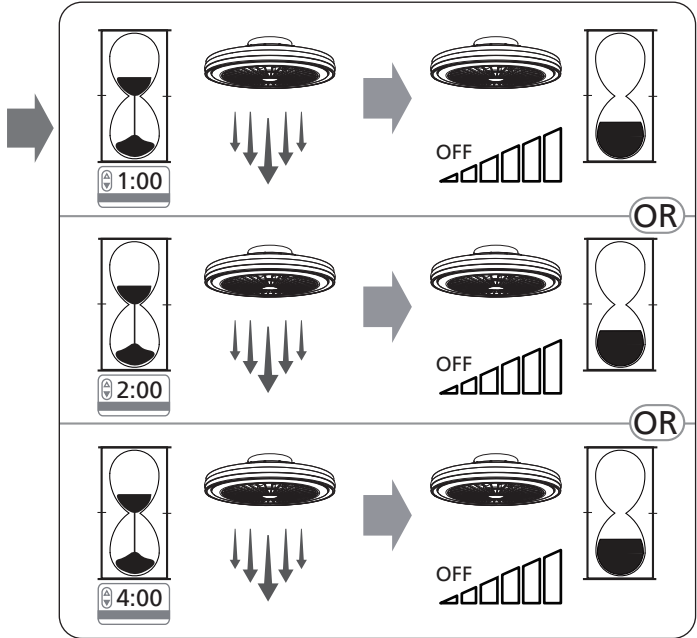
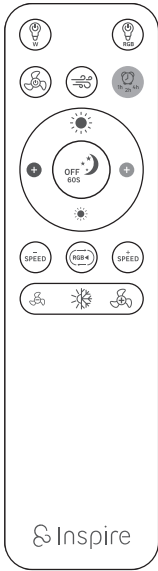

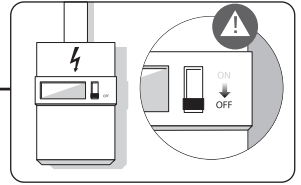

1

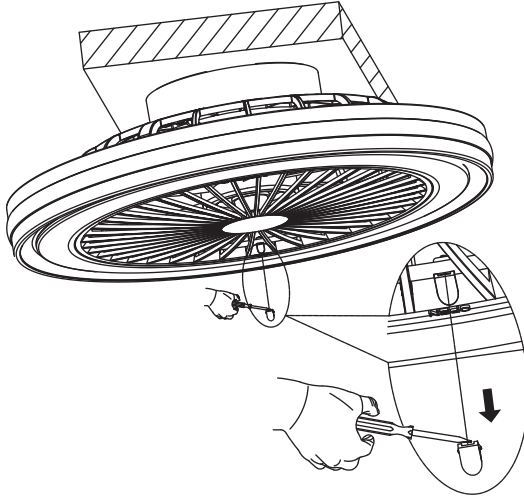

2

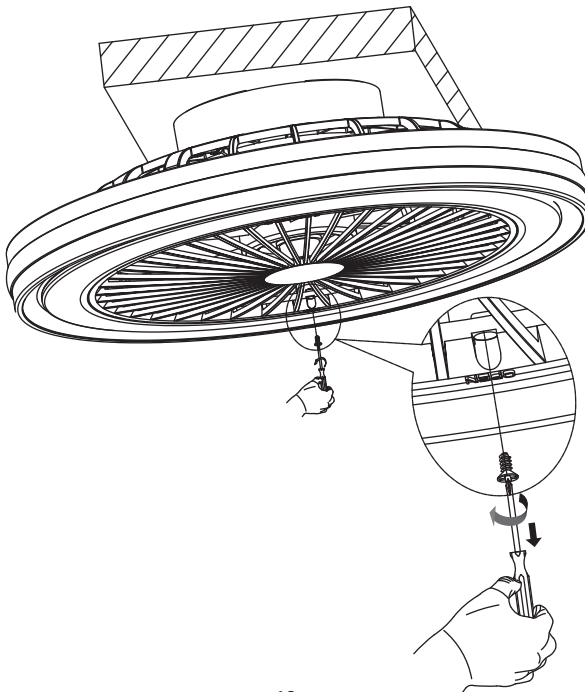

3

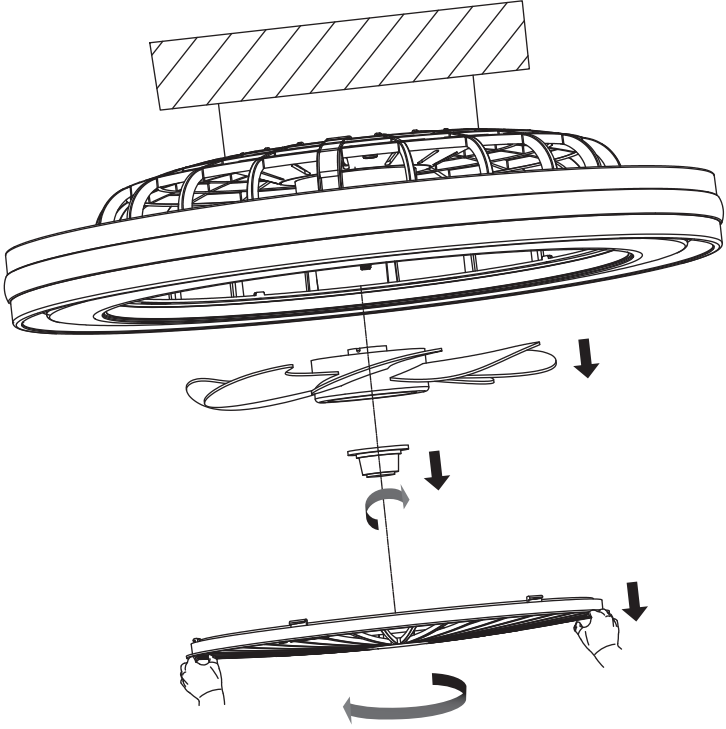



- FR** Ce produit est recyclable. S'il ne peut plus être utilisé, veuillez l'apporter dans un centre de recyclage de déchets.
- ES** Este producto es reciclable. Si ya no se puede usar, llévelo a un centro de reciclaje de residuos.
- PT** Este produto é reciclável. Se deixar de o utilizar, entregue-o num centro de reciclagem de resíduos.
- IT** Questo prodotto può essere riciclato. Se deve essere smaltito, portalo presso un centro di riciclaggio.
- EL** Αυτό το προϊόν είναι ανακυκλώσιμο. Εάν δεν μπορεί πλέον να χρησιμοποιηθεί, μεταφέρετε την σε κάποιο κέντρο ανακύκλωσης απορριμμάτων.
- PL** Ten produkt poddawany jest recyklingowi, kiedy przestaje być użyteczny należy dostarczyć go do punktu zbiórki odpadów.
- UA** Цей продукт може перероблятися. Якщо воно більше не є придатне для використання, здайте його в утилізаційний центр.
- RO** Acest produs este reciclabil. Dacă nu mai poate fi folosit, vă rugăm să îl aduceți într-un centru de reciclare a deșeurilor.
- BR** Este produto é reciclável. Se não puder mais ser usado, descarte em um centro de reciclagem de resíduos.
- DE** Dieses Produkt ist recycelbar. Wenn es nicht mehr verwendet werden kann, bringen Sie es bitte zum Recycling-Center.
- EN** This product is recyclable. If it cannot be used anymore, please take it to waste recycling centre.



FR: Traduction de la version originale du mode d'emploi / ES: Traducción de las Instrucciones originales / PT: Tradução das Instruções Originais / IT: Traduzione delle istruzioni originali / EL: Μετάφραση των πρωτότυπων οδηγιών / PL: Tłumaczenie instrukcji oryginalnej / UA: Переклад оригінальної інструкції / RO: Traducerea instrucțiunilor originale / BR: Tradução das Instruções Originais / DE: Übersetzung der Originalversion der Gebrauchsanweisung / Original Instructions.

Made in China
Країна походження: Китай

EU ADEO Services - 135 Rue Sadi Carnot - CS00001 - 59790 RONCHIN - FRANCE

UA Виробник: ТОВ "Адео Сервісез С.А.", вул. Саді Карно, CS 00001, 59790 Роншен, Франція. Імпортер: ТОВ "Леруа Мерлен Україна", 04201 Україна, м. Київ, вул. Полярна 17А, +380 44 498 46 00. Імпортер приймає претензії від споживачів щодо товару, а також проводить його ремонт, технічне і гарантійне обслуговування

BR LEROY MERLIN COMPANHIA BRASILEIRA DE BRICOLAGEM CNPJ: 01.438.784/0001-05
Rua Pascoal Pais, nº. 525, 6º andar cj 61 a 64, Vila Cordeiro, São Paulo - SP. CEP: 04581-060
CALM (Central de Atendimento Leroy Merlin)
Capitais 4020-5376 Demais Regiões 0800-0205376

ZA Imported by Adeo South Africa (PTY) LTD T/A Leroy Merlin, Hosted in Leroy Merlin Fourways Store 35 Roos Street, Witkoppen Ext 97, Sandton, 2191 Johannesburg, Gauteng, South Africa. Tel: +27 10 493 8000 Email: contact@leroymerlin.co.za.

