

 **Spaceo**

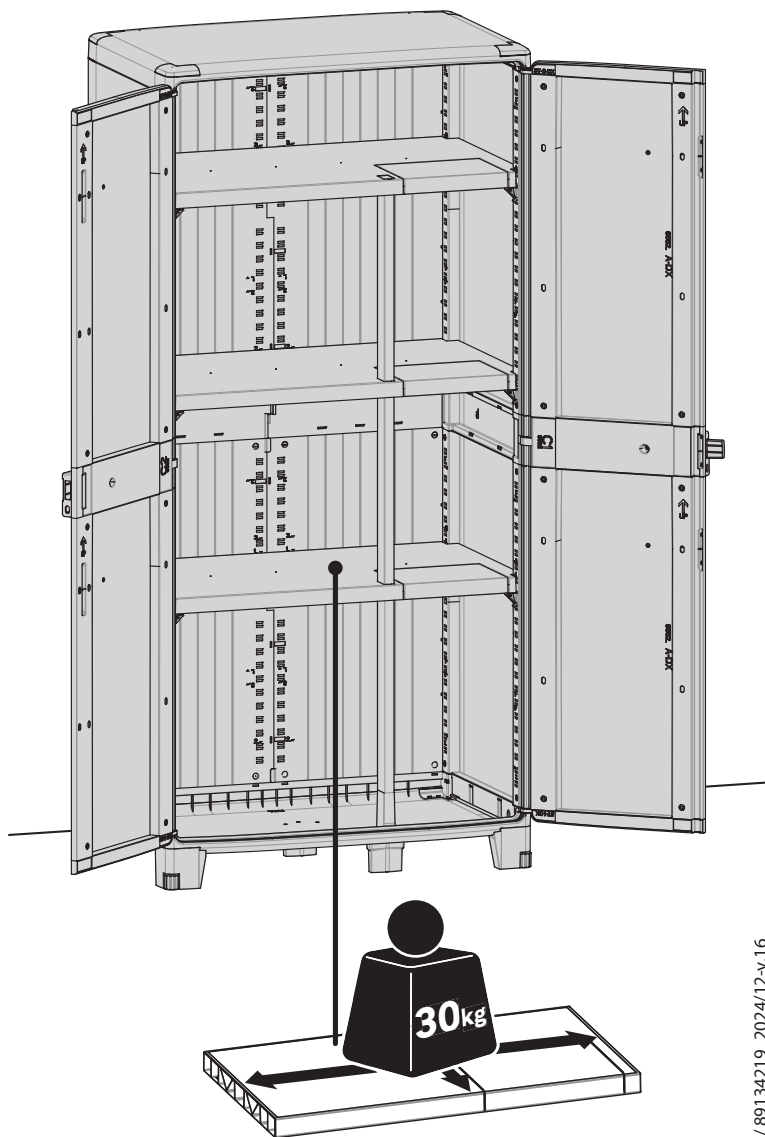

**7**  
**YEAR**  
Guarantee\*

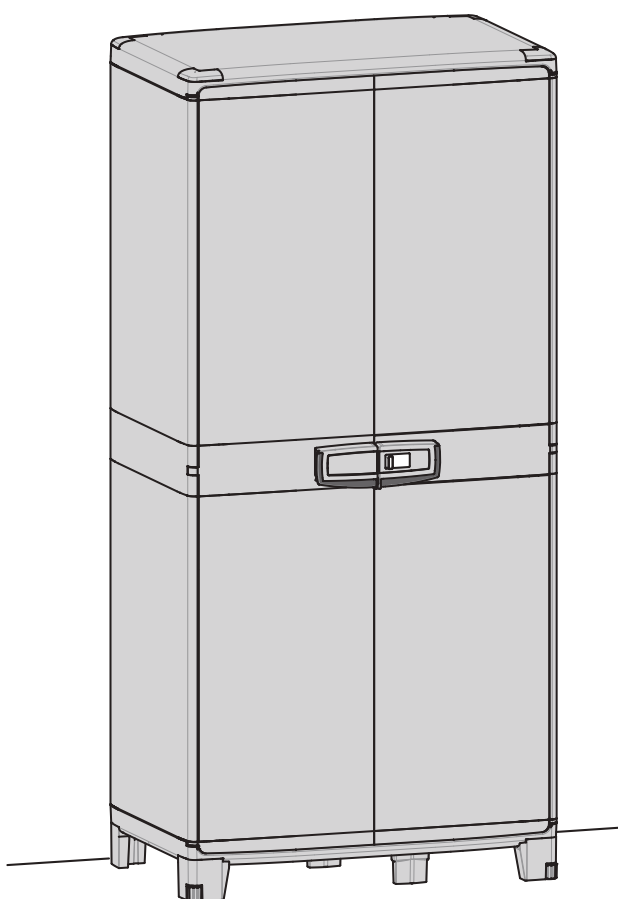

EAN: 3276007359237

EAN: 3276007359251



**FR** Notice de Montage -  
Utilisation - Entretien

**ES** Instrucciones de Montaje,  
Utilización y Mantenimiento

**PT** Instruções de Montagem,  
Utilização e Manutenção

**IT** Istruzioni per il Montaggio,  
l'Uso e la Manutenzione

**EL** Εγχειρίδιο συναρμολόγησης,  
χρήσης και συντήρησης

**PL** Instrukcja Montażu,  
Użytkowania i Konserwacji

**RO** Instrucțiuni de asamblare  
- Utilizare - Întreținere

**EN** Assembly - Use -  
Maintenance Manual

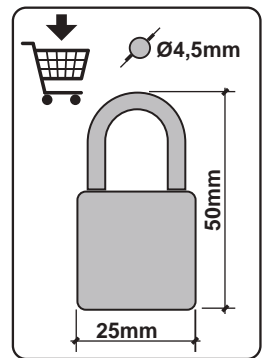
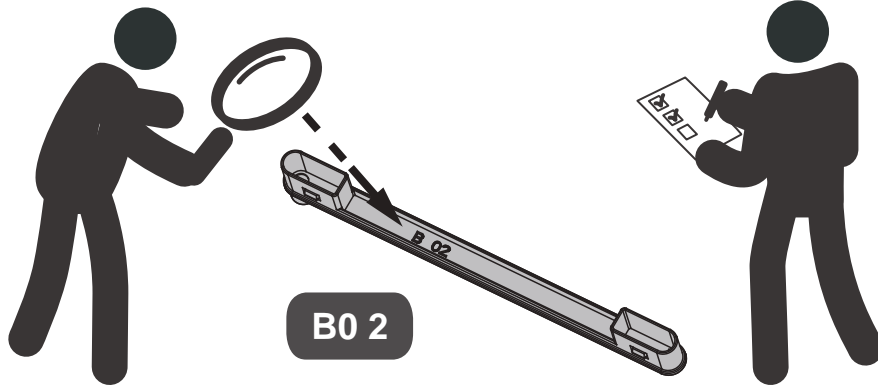
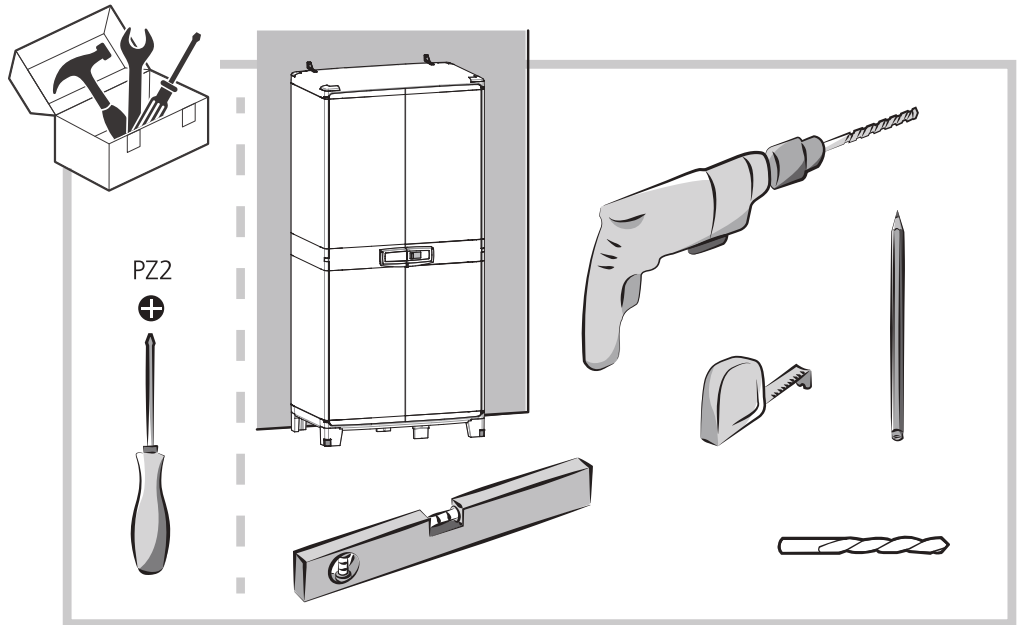
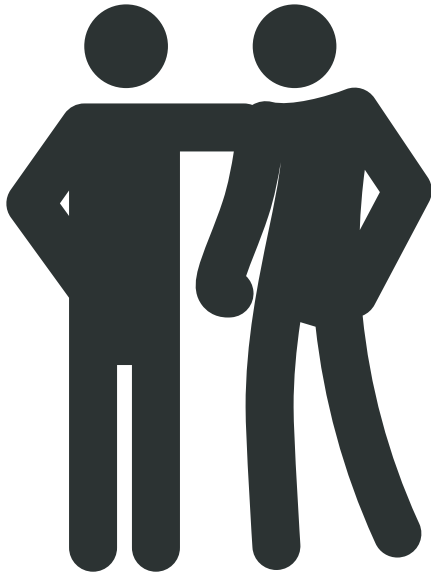

**FR/ PIECE DETACHEES**

Certains éléments de ce produit peuvent être commandés auprès de votre magasin.

**ES/ PIEZAS DE RECAMBIO**

Algunos elementos de este producto se pueden pedir en su tienda.

**PT/ PEÇAS SOBRESSALENTES**

Algumas peças deste produto podem ser encomendadas na sua loja.

**IT/ PEZZI DI RICAMBIO**

Alcuni elementi di questo prodotto possono essere ordinati nel vostro negozio.

**EL/ ΑΝΤΑΛΛΑΚΤΙΚΑ**

Μπορείτε να παραγγείλετε ορισμένα ανταλλακτικά του προϊόντος από το κατάστημά σας.

**RO/ PIESE DE SCHIMB**

numite componente ale acestui produs pot fi comandate la magazinul dvs.

**PL/ CZĘŚCI ZAMIENNE**

Niektóre części tego produktu można zamówić w twoim sklepie.

**EN/ SPARE PARTS**

Some parts of this product can be ordered from your store.

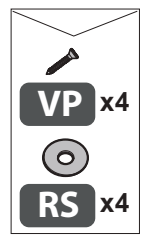
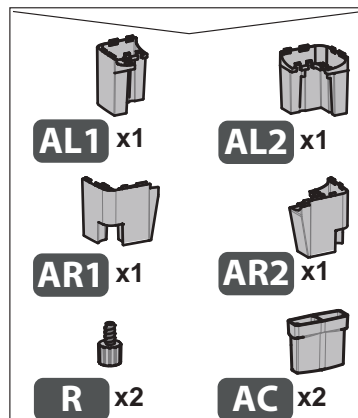
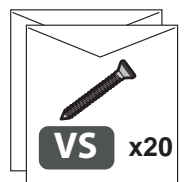
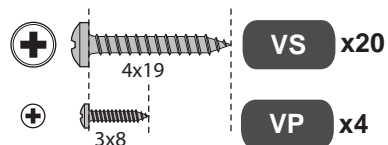
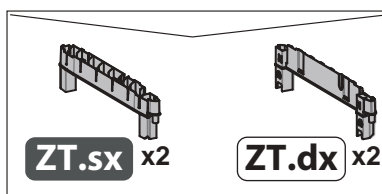
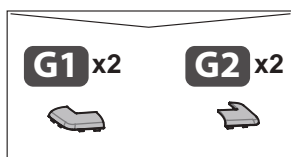
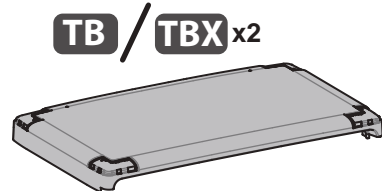
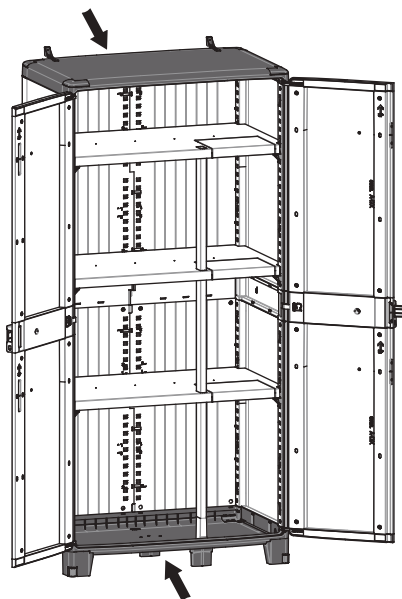

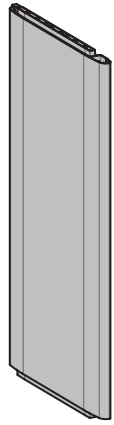
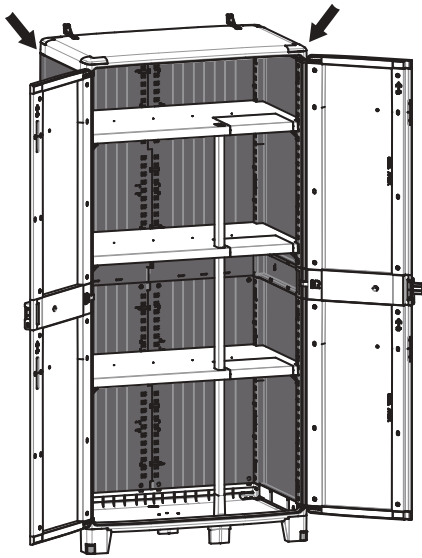

**PL** x4

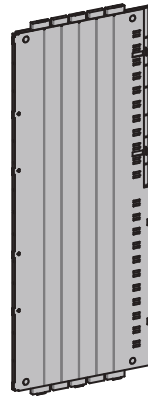

**F** x4

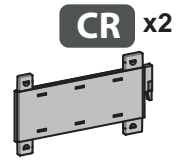

**CR** x2

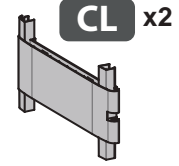

**CL** x2

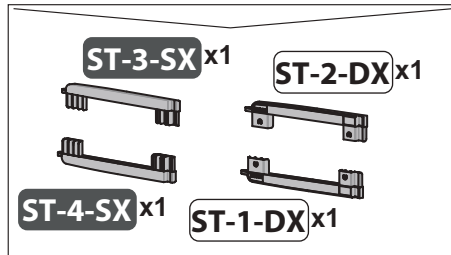
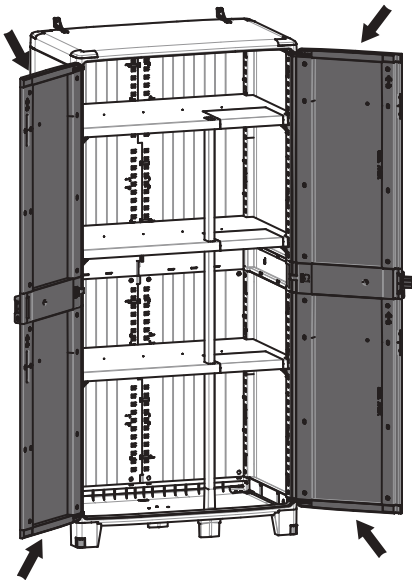

**ST-3-SX** x1

**ST-2-DX** x1

**ST-4-SX** x1

**ST-1-DX** x1

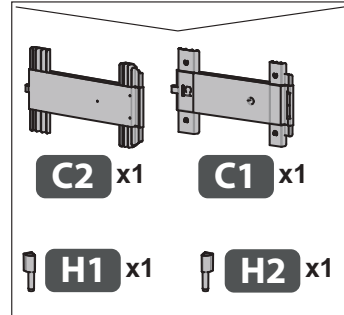

**C2** x1

**C1** x1

**H1** x1

**H2** x1



**A-SX** x2



**A-DX** x2



**K2** x1



**K1** x1



**K** x1

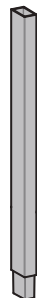
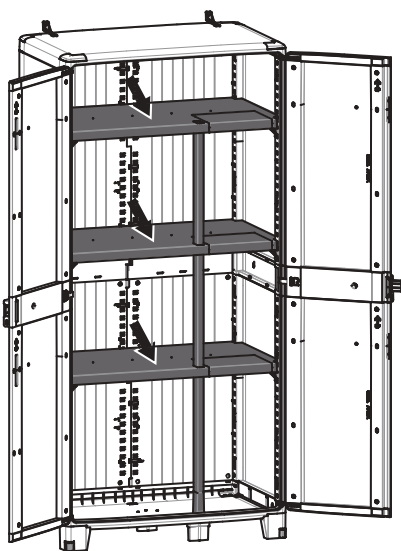

**M** x3



**SC** x1

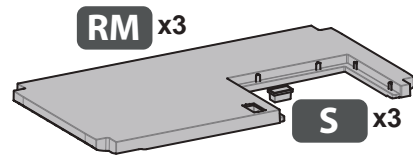

**RM** x3

**S** x3

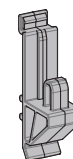

**O** x18

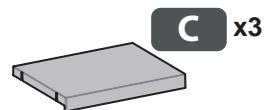

**C** x3

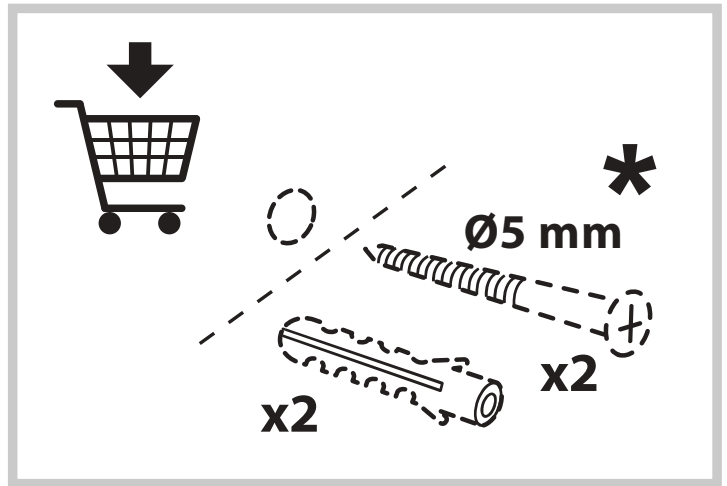
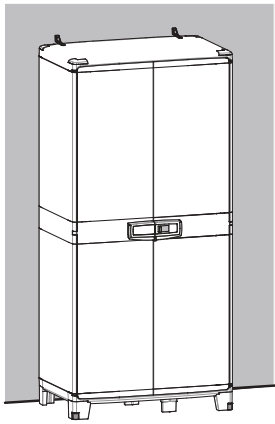

### FR/ AVERTISSEMENT :

Pour éviter tout risque de basculement, ce meuble/cet objet doit être solidement fixé au mur. Vérifier la pertinence et la solidité du mur afin de s'assurer que le mur puisse supporter la charge du meuble/de l'objet et résister aux forces générées au niveau des fixations. Un montage mal effectué peut provoquer la chute du meuble/de l'objet et des blessures graves sur les personnes. En cas de doute concernant l'installation, demandez conseil à un vendeur spécialisé ou contactez un professionnel.

★ Utilisez des vis, rondelles et chevilles adaptées au type de matériau de votre mur. Celles-ci ne sont pas incluses. Pour obtenir des conseils sur les vis et ferrures adaptées à votre mur, adressez-vous à un vendeur spécialisé.

### PT/ AVISO:

Para evitar qualquer risco de basculamento, este móvel/objeto deve ser fixo à parede de forma segura. Verifique a adequabilidade e solidez da parede para se certificar de que pode suportar a carga do móvel/objeto e resistir às forças aplicadas ao nível das fixações. Uma montagem mal feita pode originar a queda do móvel/objeto e provocar danos pessoais graves. Em caso de dúvida em relação à instalação, peça aconselhamento a um vendedor especializado ou contacte um profissional.

★ Utilize parafusos, anilhas e buchas adaptadas ao tipo de material da sua parede. Estes elementos de fixação não estão incluídos. Para obter aconselhamento sobre os parafusos e ferragens adaptados à sua parede, consulte um vendedor especializado.

### EL/ ΠΡΟΕΙΔΟΠΟΙΗΣΗ:

Για την αποφυγή οποιουδήποτε κινδύνου ανατροπής, το έπιπλο/ αντικείμενο πρέπει να στερεώνεται σταθερά στον τοίχο. Βεβαιωθείτε για την καταλληλότητα και σταθερότητα του τοίχου, προκειμένου να διασφαλίσετε ότι μπορεί να υποστηρίξει το φορτίο του επίπλου/ αντικείμενου και να αντέξει στις δυνάμεις που δημιουργούνται στα σημεία των στηριγμάτων. Η κακή τοποθέτηση μπορεί να οδηγήσει σε πτώση του επίπλου/ αντικείμενου και σε σοβαρούς τραυματισμούς ατόμων. Σε περίπτωση αμφιβολίας σχετικά με την εγκατάσταση, ζητήστε συμβουλές από έναν εξειδικευμένο πωλητή ή καλέστε έναν επαγγελματία.

★ Χρησιμοποιήστε κατάλληλες βίδες, ροδέλες και ούπα ανάλογα με το υλικό της τοιχοποιίας σας. Τα υλικά αυτά δεν περιλαμβάνονται. Για συμβουλές σχετικά με τις βίδες και τα μεταλλικά στηρίγματα που ενδείκνυνται για τον τοίχο σας, απευθυνθείτε σε έναν εξειδικευμένο πωλητή.

### RO/ AVERTIZARE:

Pentru a evita orice risc de basculare, această mobilă/acest obiect trebuie fixat/ă bine de perete. Verificați rezistența și soliditatea peretelui, pentru a vă asigura că acesta poate suporta greutatea mobilei/obiectului și poate rezista forțelor generate la nivelul dispozitivelor de fixare. Montarea efectuată greșit poate determina căderea mobilei/obiectului și vătămarea gravă a persoanelor. În caz de dubii privind instalarea, cereți sfatul unui comerciant specializat sau contactați un profesionist.

★ Utilizați șuruburi, șaibe și dibluri adaptate tipului de material a peretelui. Acestea nu sunt incluse. Pentru a obține recomandări privind șuruburile și piesele adaptate peretelui dvs., adresați-vă unui comerciant specializat.

### ES/ ADVERTENCIA:

Para evitar cualquier riesgo de que se vuelque, el mueble u objeto debe anclarse firmemente a la pared. Compruebe la adecuación y la solidez de la pared para asegurarse de que puede soportar el peso del mueble u objeto y resistir las fuerzas que se produzcan en las fijaciones. Un montaje inadecuado puede causar la caída del mueble u objeto y que se produzcan daños corporales. En caso de duda en relación a la instalación, pregunte a un vendedor especializado o recurra a un profesional.

★ Utilice tornillos, arandelas y tacos adecuados para el material de la pared. El producto no incluye la tornillería ni los tacos de sujeción. Para saber cuáles son los elementos de fijación más adecuados para su pared, pregunte a un vendedor especializado.

### IT/ ATTENZIONE:

Per evitare un eventuale rischio di ribaltamento, il mobile/l'oggetto deve essere saldamente fissato alla parete. Verificare l'adeguatezza e la solidità della parete per essere sicuri che la stessa possa sopportare il carico del mobile/dell'oggetto e resistere alle forze generate a livello di fissaggi. Un montaggio non effettuato correttamente può provocare la caduta del mobile/dell'oggetto e lesioni gravi alle persone. In caso di dubbio circa l'installazione, rivolgetevi a un venditore specializzato o contattate un professionista.

★ Utilizzare viti, rondelle e Pernotti (non inclusi) adeguati al tipo di materiale della vostra parete. Per informazioni su viti e ferramenta adatti alla vostra parete, rivolgetevi a un venditore specializzato.

### PL/ OSTRZEŻENIE:

Aby uniknąć ryzyka przewrócenia, mebel/produkt musi zostać solidnie przymocowany do ściany. Sprawdź, czy ściana jest odpowiednia i solidna, aby mieć pewność, że jest w stanie utrzymać obciążenie mebla/produktu i siły na poziomie mocowań. Nieprawidłowo wykonany montaż może spowodować upadek mebla/produktu prowadzący do poważnych obrażeń ciała. W razie wątpliwości dotyczących montażu, należy zasięgnąć porady u kompetentnego sprzedawcy lub skontaktować się z fachowcem.

★ Użyj śrub, podkładek i kołków odpowiednich do rodzaju ściany. Elementy te nie są dołączone do zestawu. Aby zasięgnąć porady na temat odpowiednich śrub i okuć należy skontaktować się z kompetentnym sprzedawcą.

### EN/ WARNING:

To avoid any risk of toppling, this furniture item/object must be securely attached to the wall. Check the suitability and the strength of the wall to ensure that the wall can bear the load of the furniture/object and withstand the forces put on the securing elements.

Improper installation can result in the furniture/object falling and cause serious injuries to people. In case of a doubt regarding the installation, ask for advice from a specialised sales assistant or contact a professional.

★ Use screws, washers and plugs suited to the type of material of your wall. These are not included. To obtain advice on the screws and fittings suited to your wall, ask a specialised sales assistant.

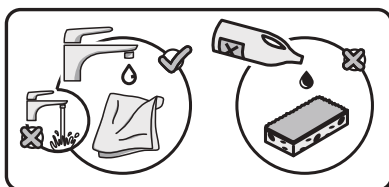

- |   |  |   |  |
|---|--|---|--|
| a | <b>Ne pas appliquer de solvant sur le produit.</b> | e | <b>Μην εφαρμόζετε διαλύτη στο προϊόν.</b>      |
| b | <b>No aplique solvente al producto.</b>            | f | <b>Nie nanosić rozpuszczalnika na produkt.</b> |
| c | <b>Não aplique solvente no produto.</b>            | k | <b>Nu aplicați solvent pe produs.</b>          |
| d | <b>Non applicare solventi al prodotto.</b>         | m | <b>Do not apply solvents to the product.</b>   |



01

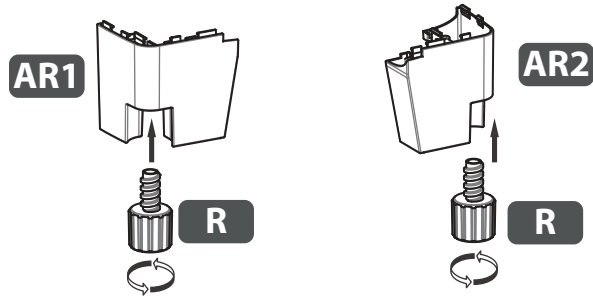

02

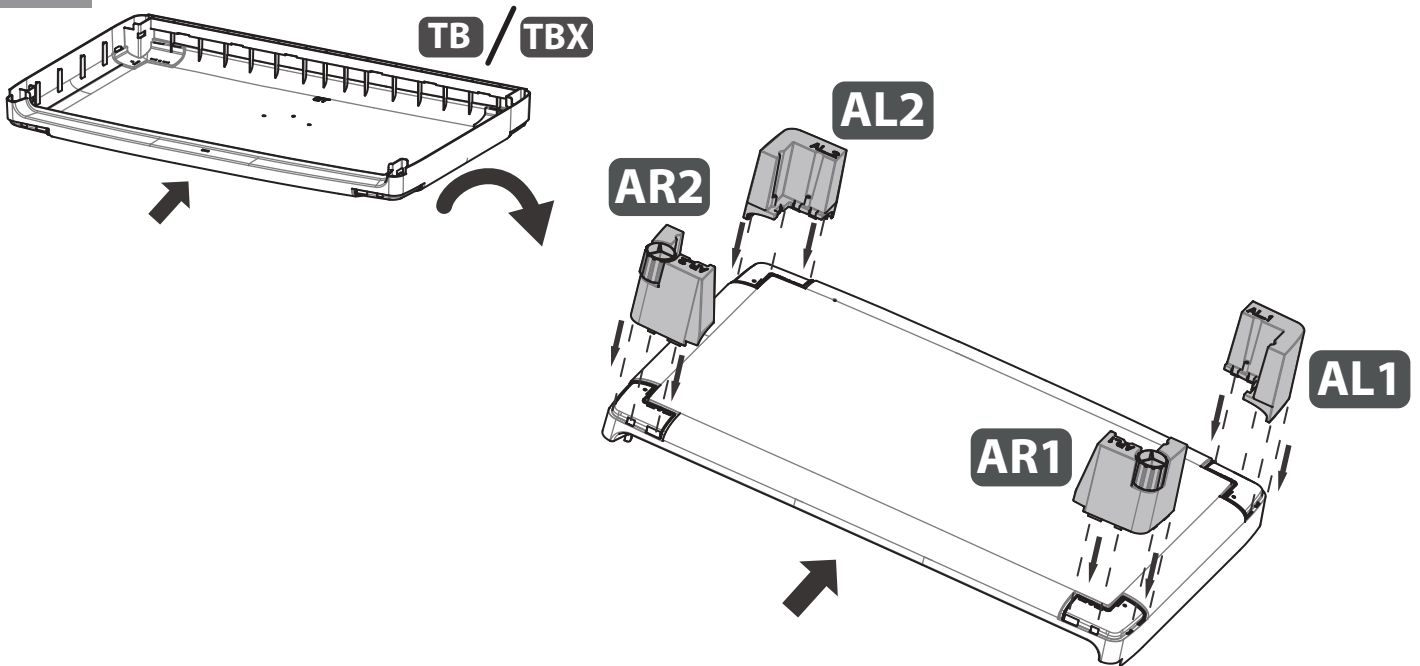

03

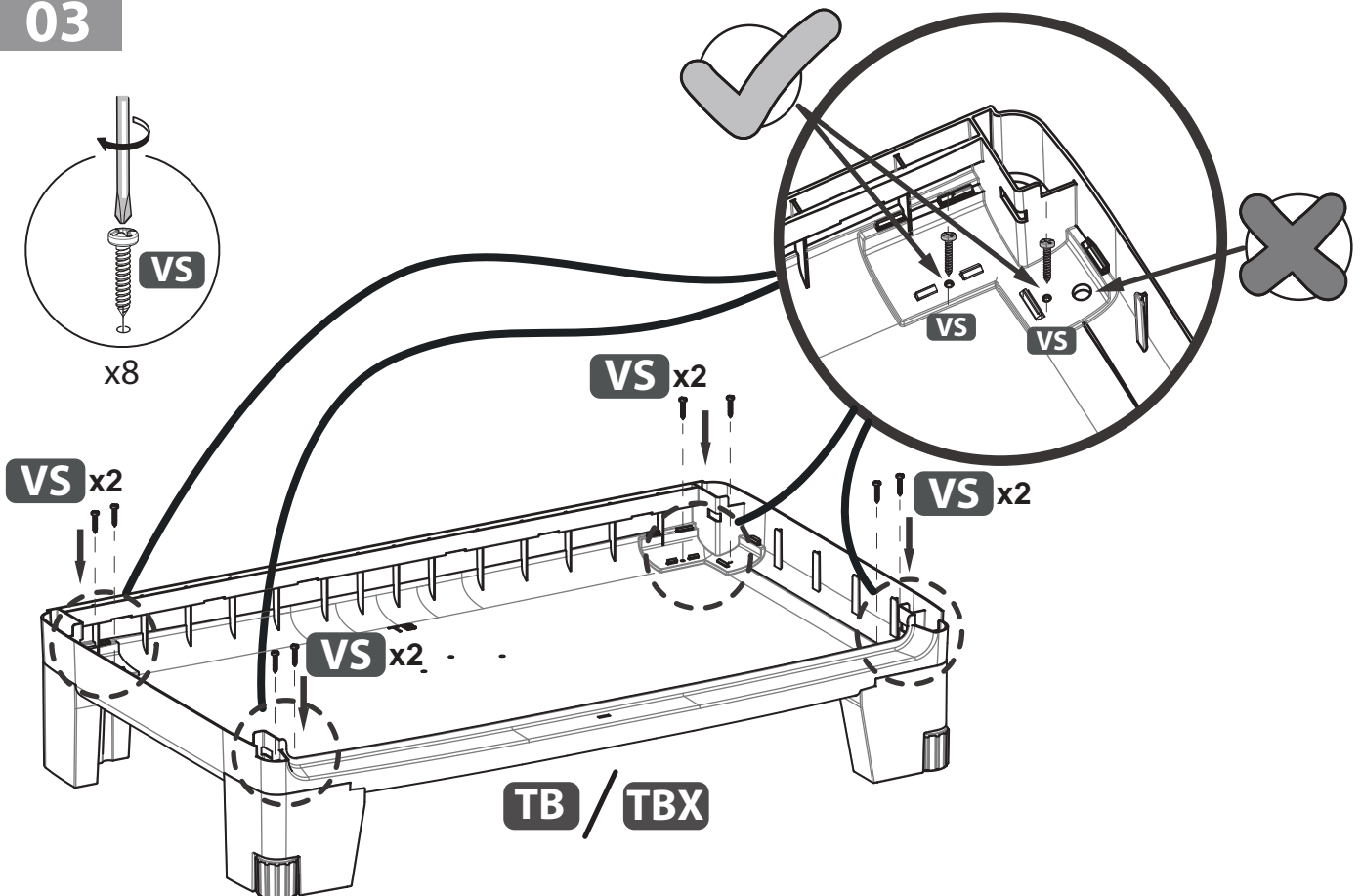

04

EAN: 3276007359237

EAN: 3276007359251

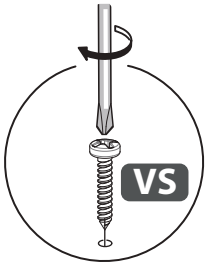

x6

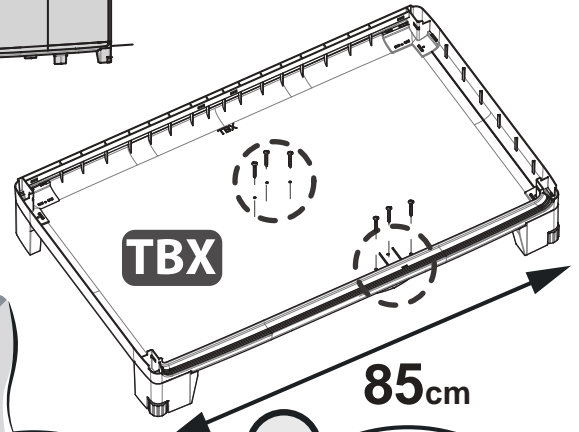
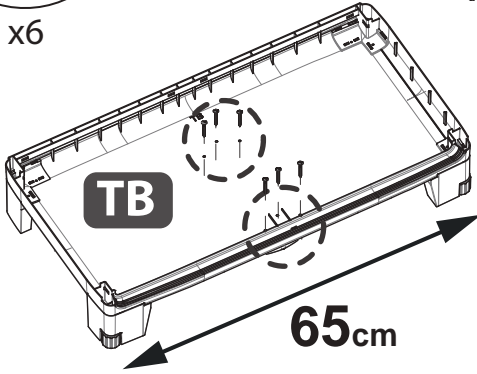
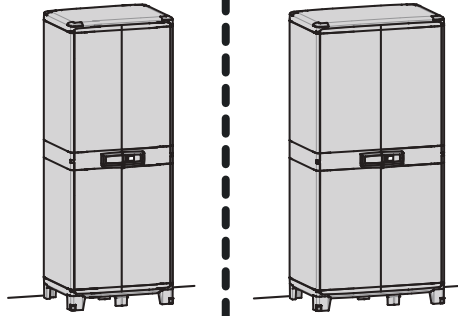

05

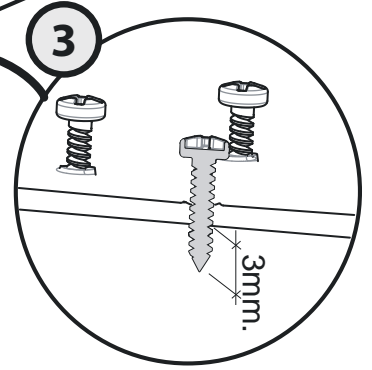
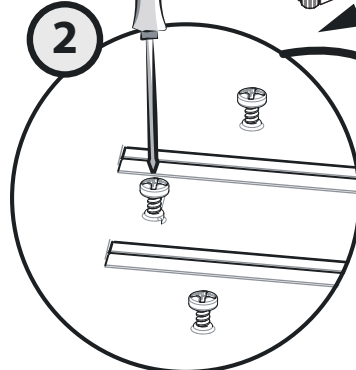
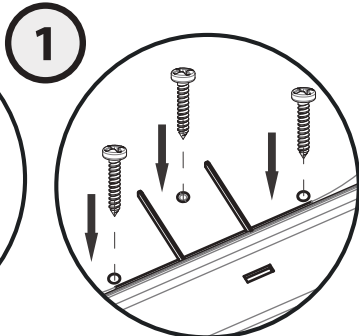
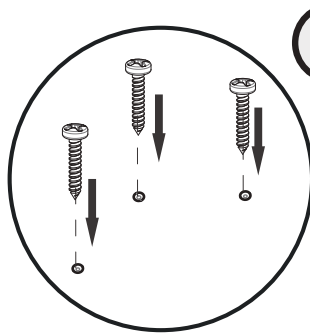

06

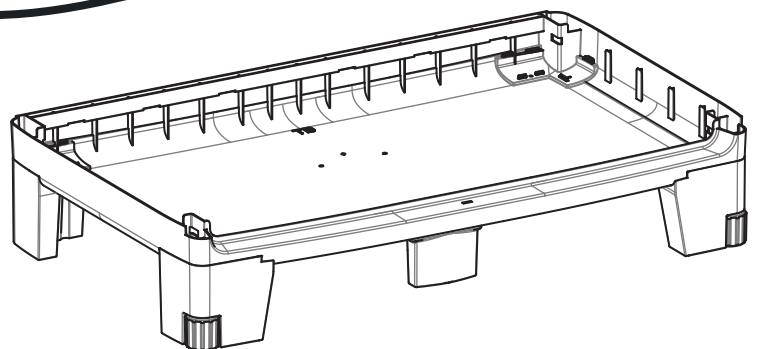
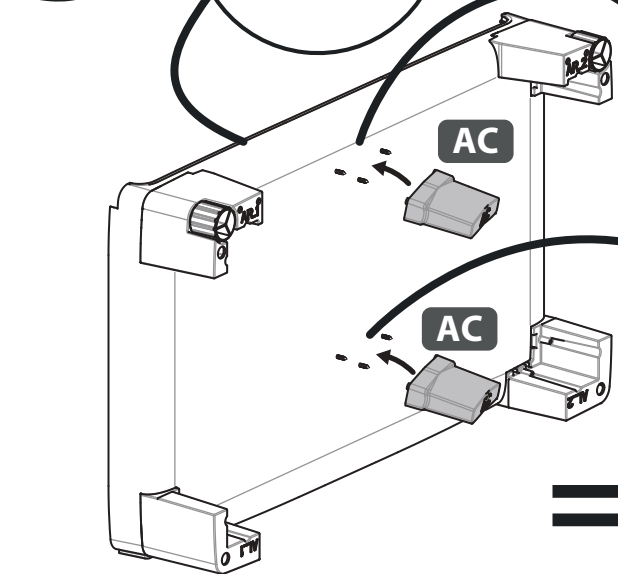
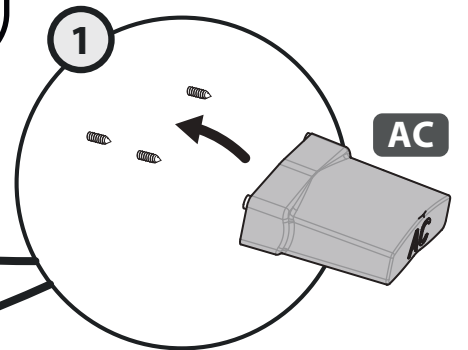
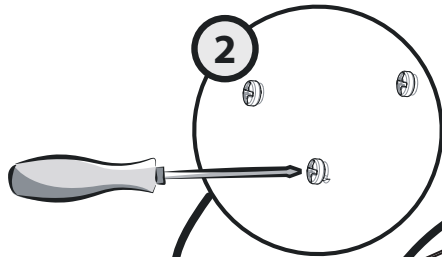

07

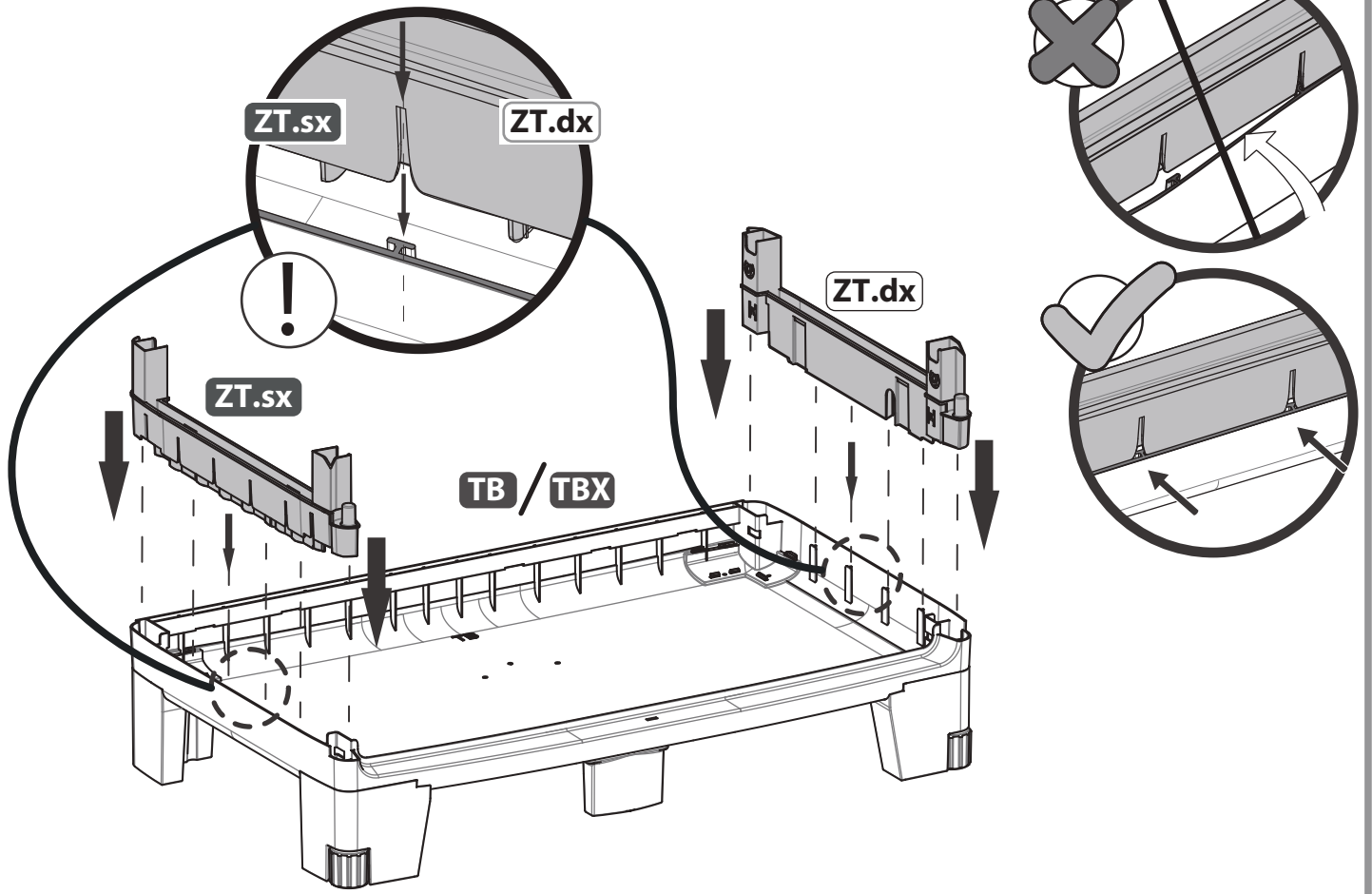

08

09

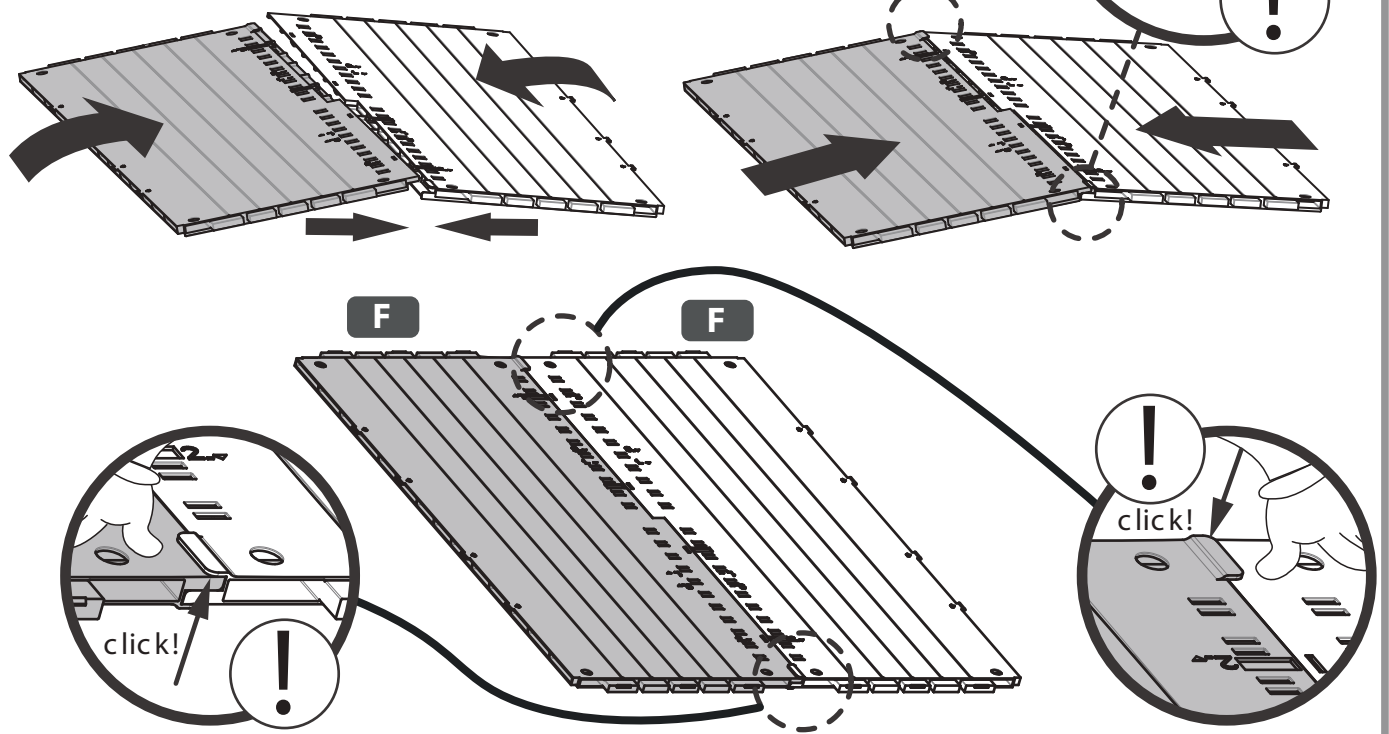

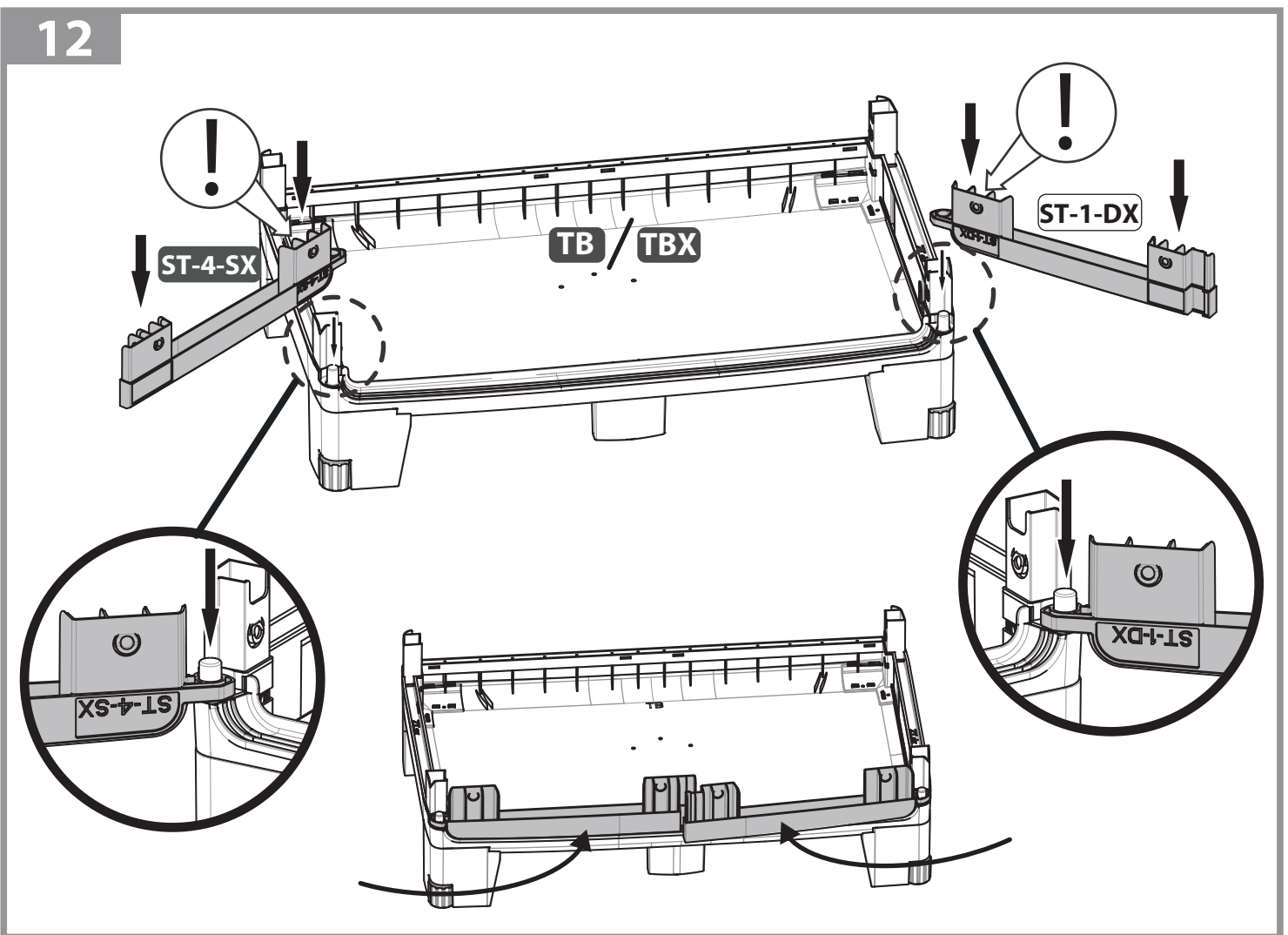
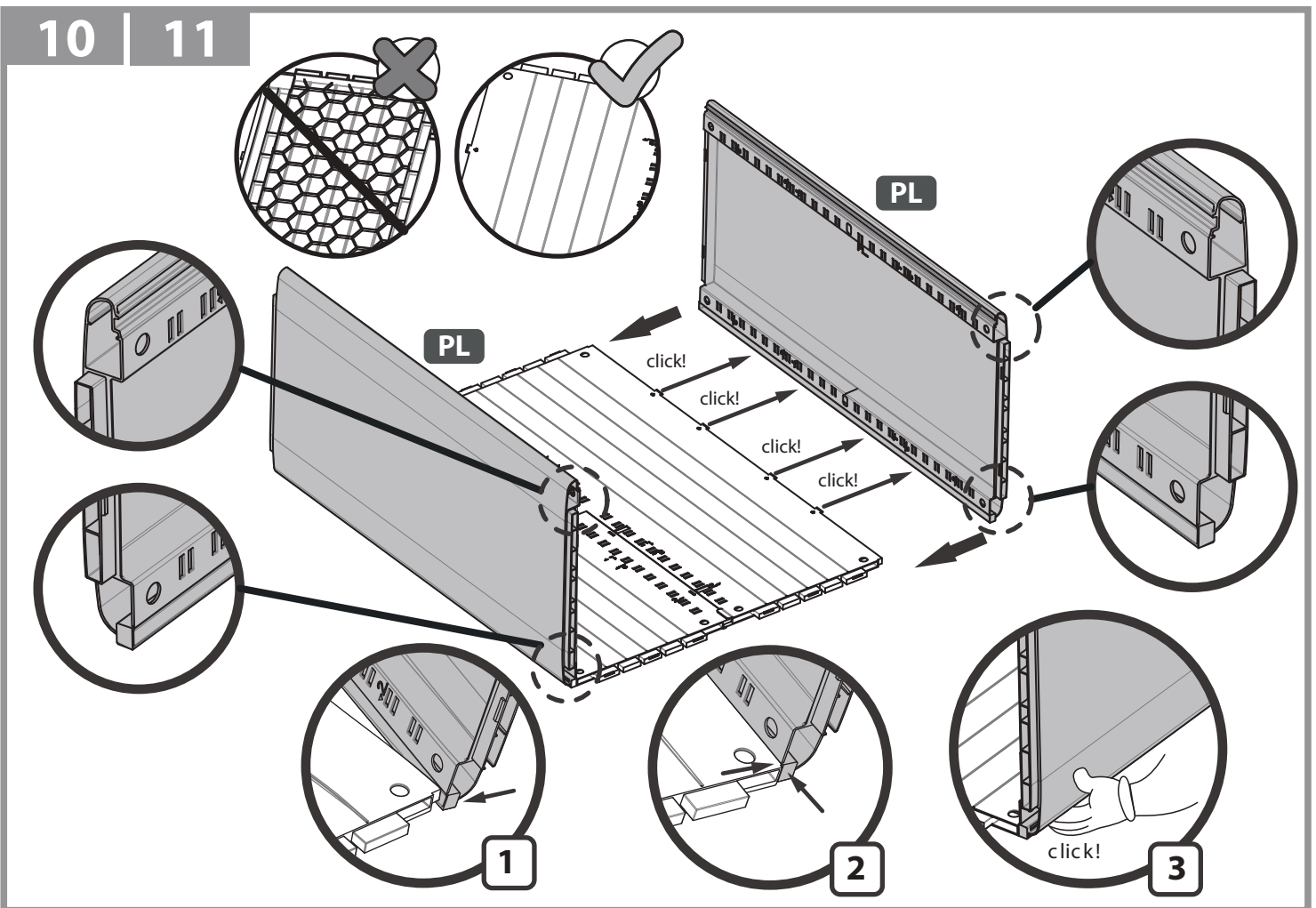

13

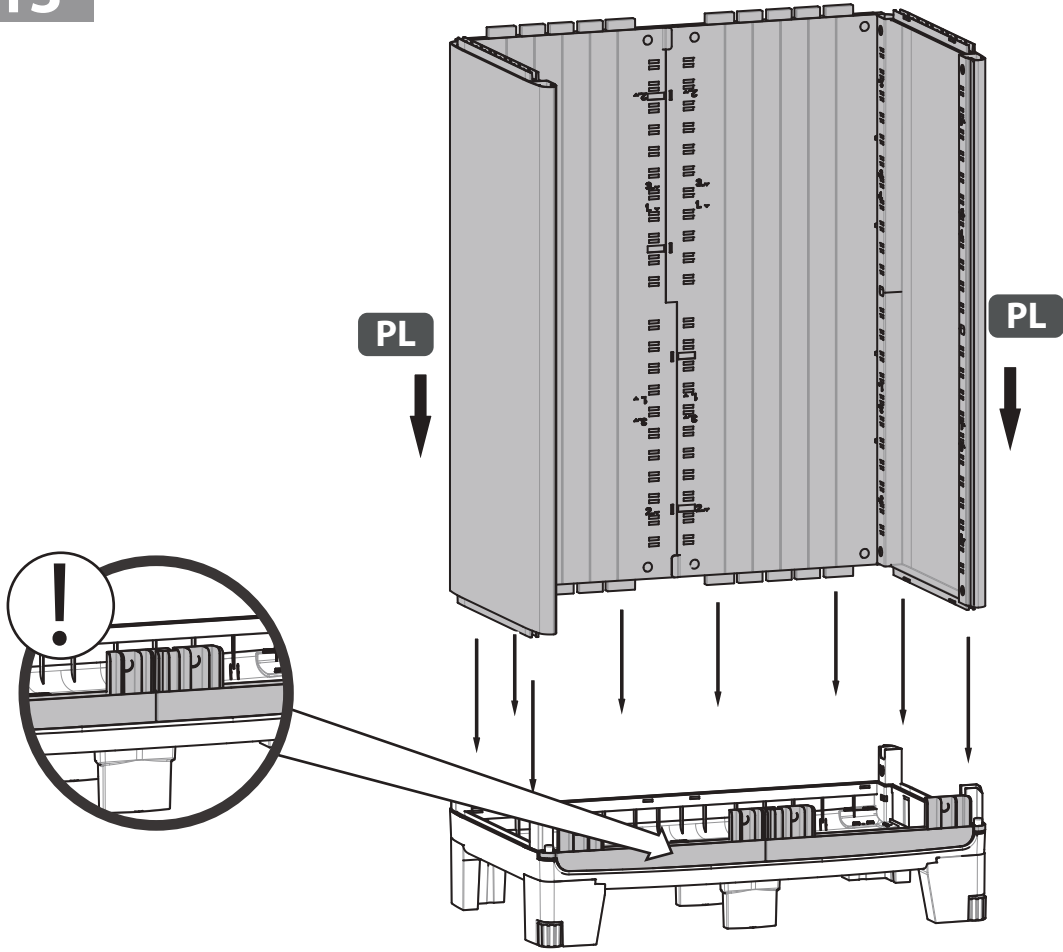

14

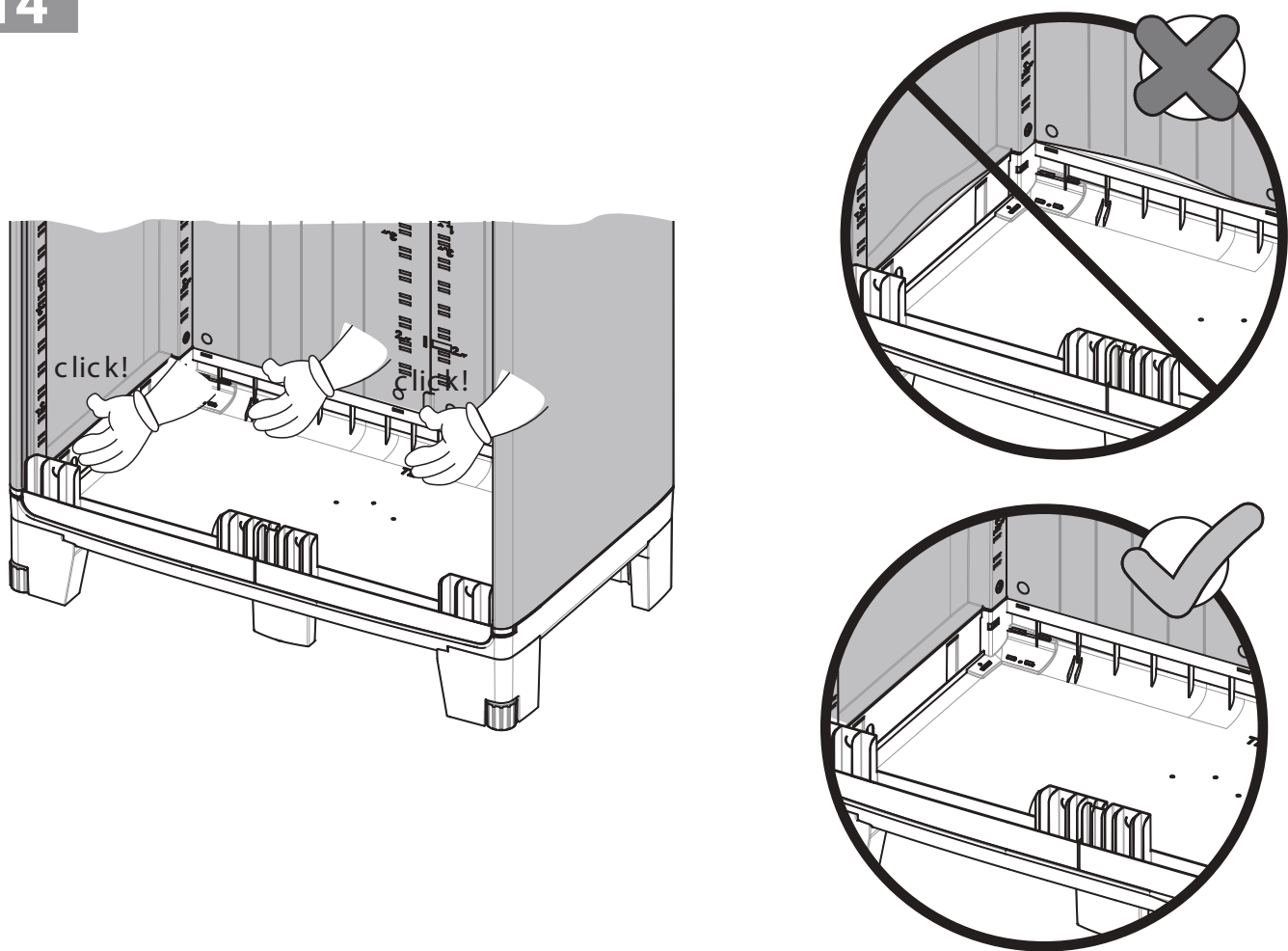

15

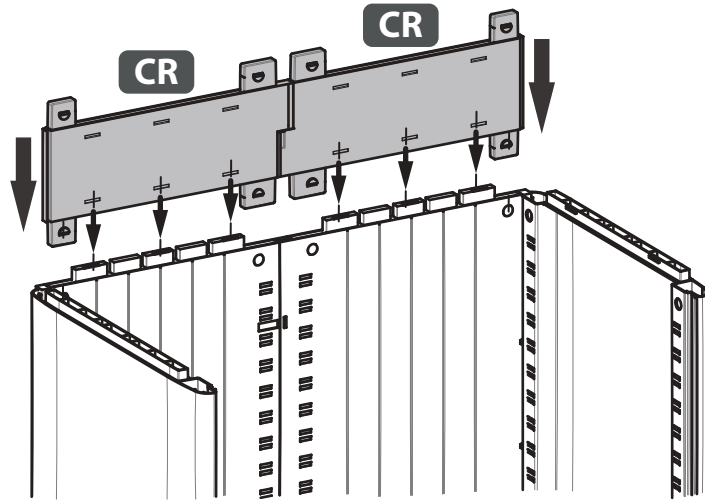
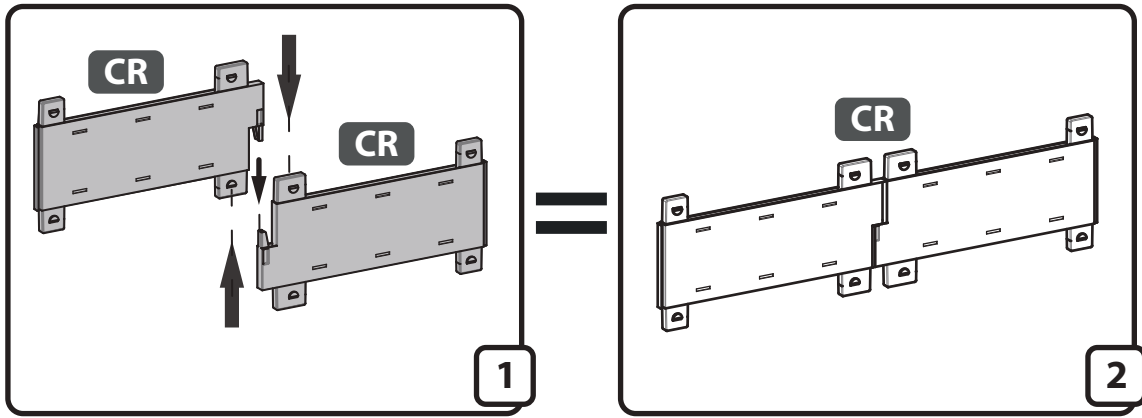

16 | 17

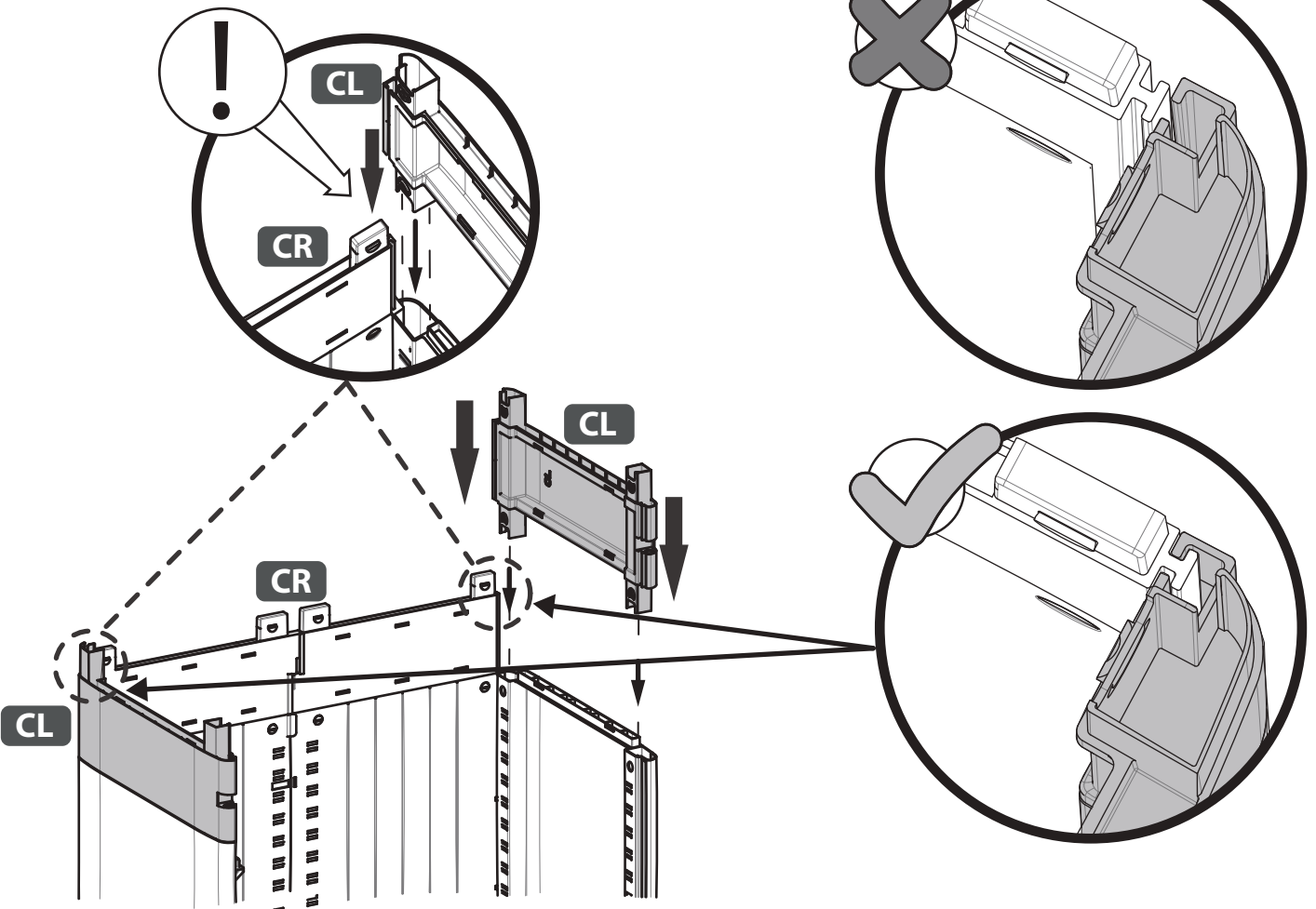



18

19

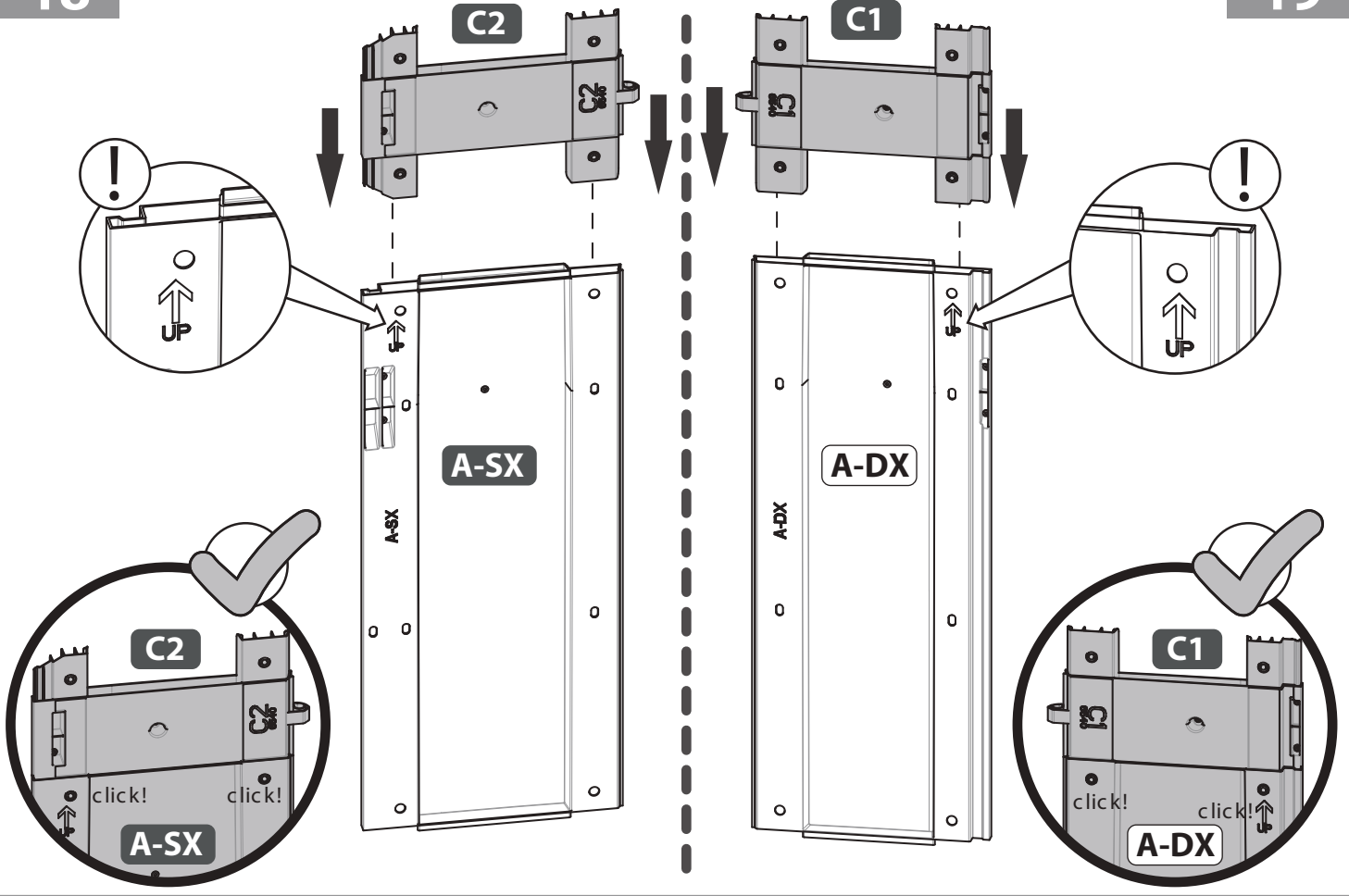

20

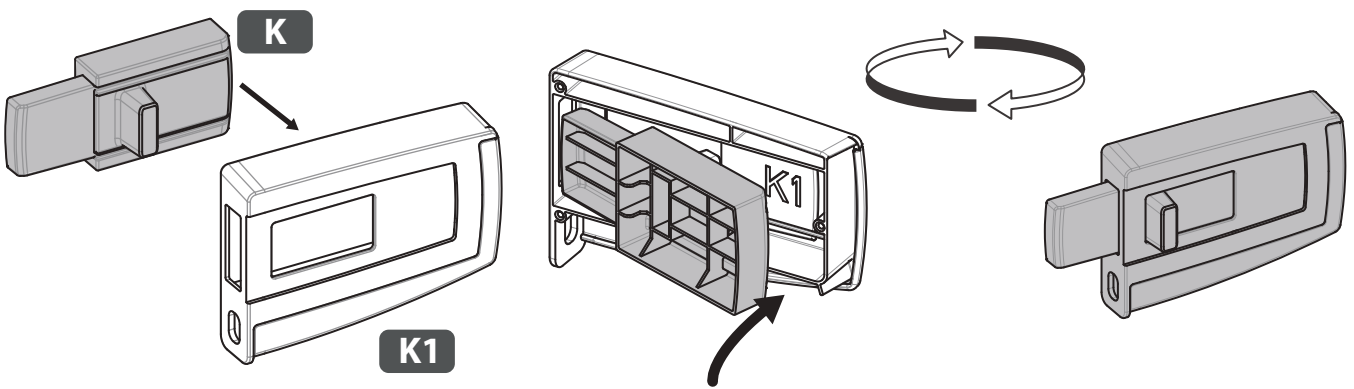



21

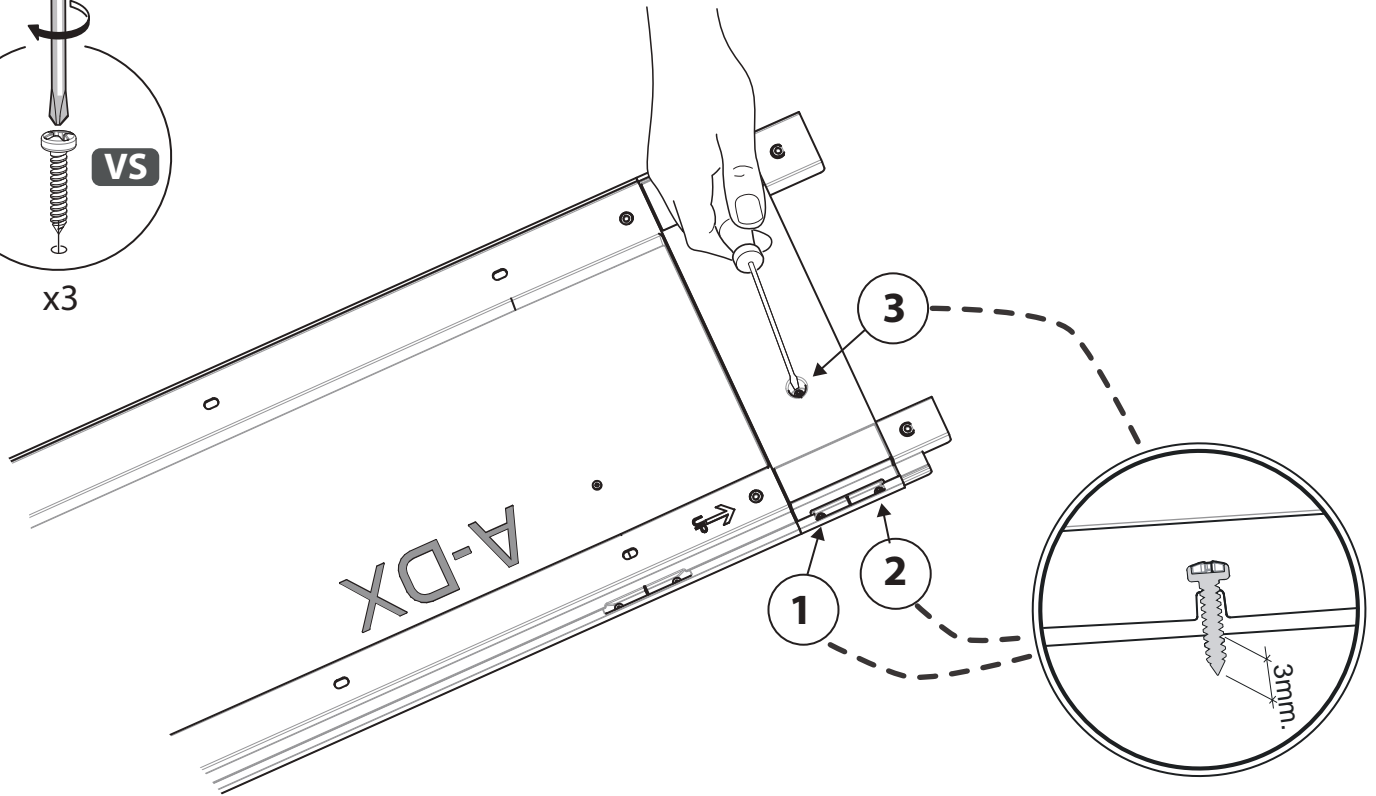
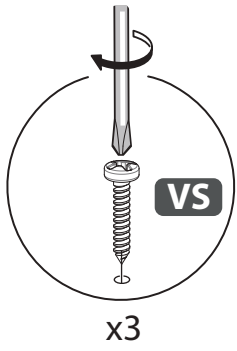

22

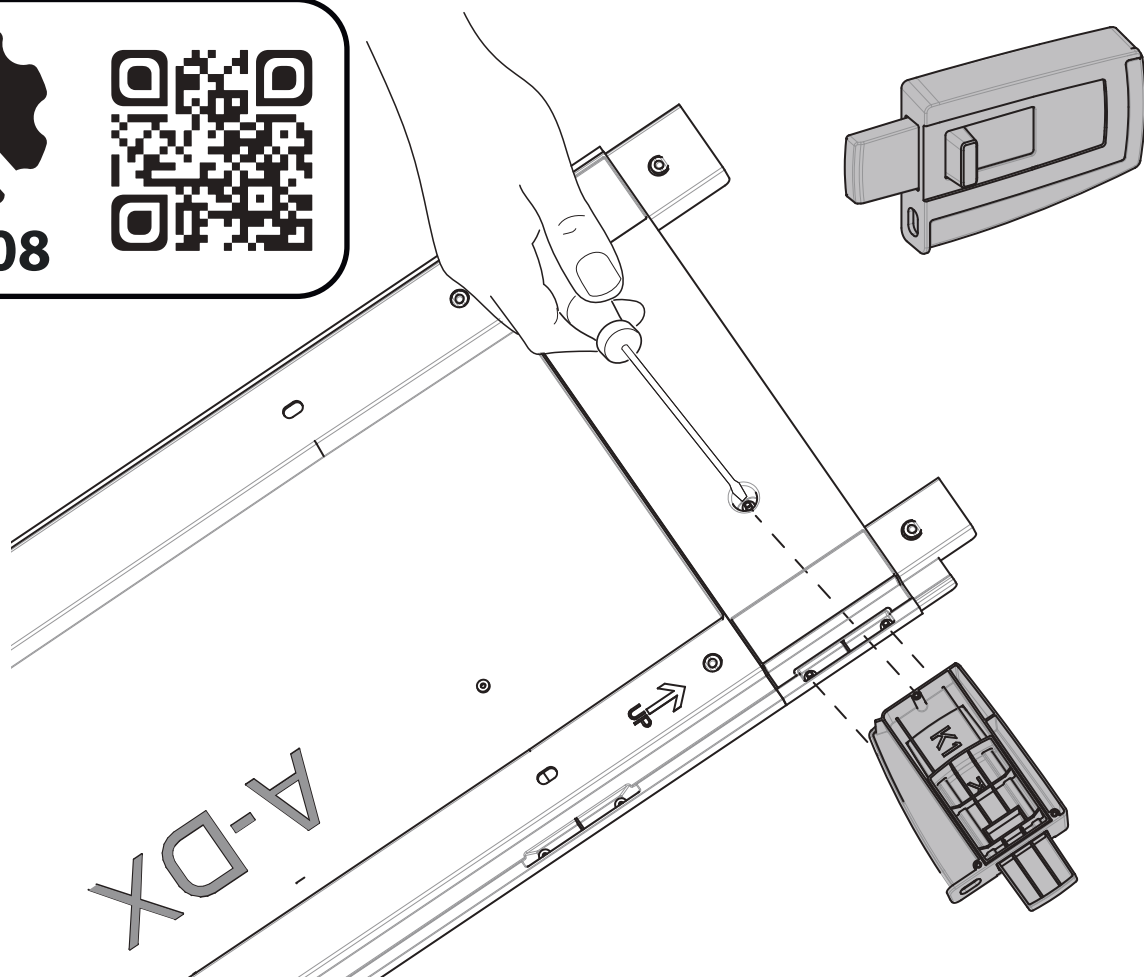

23

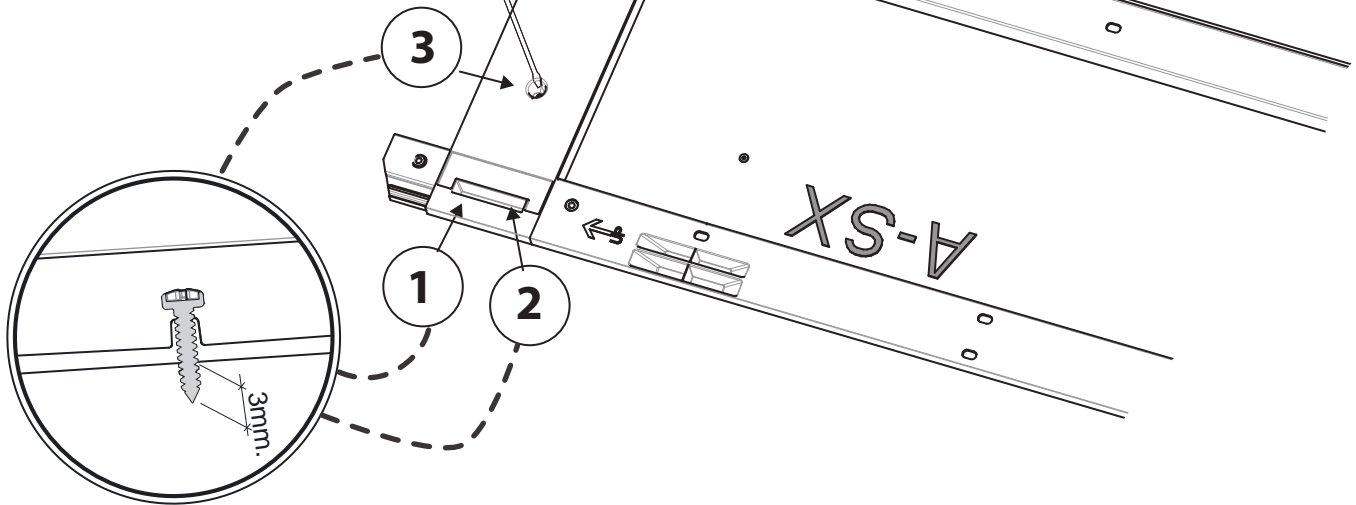
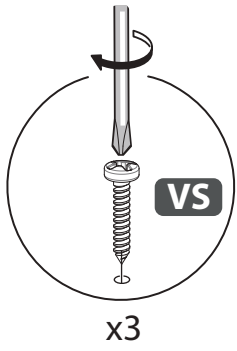

24

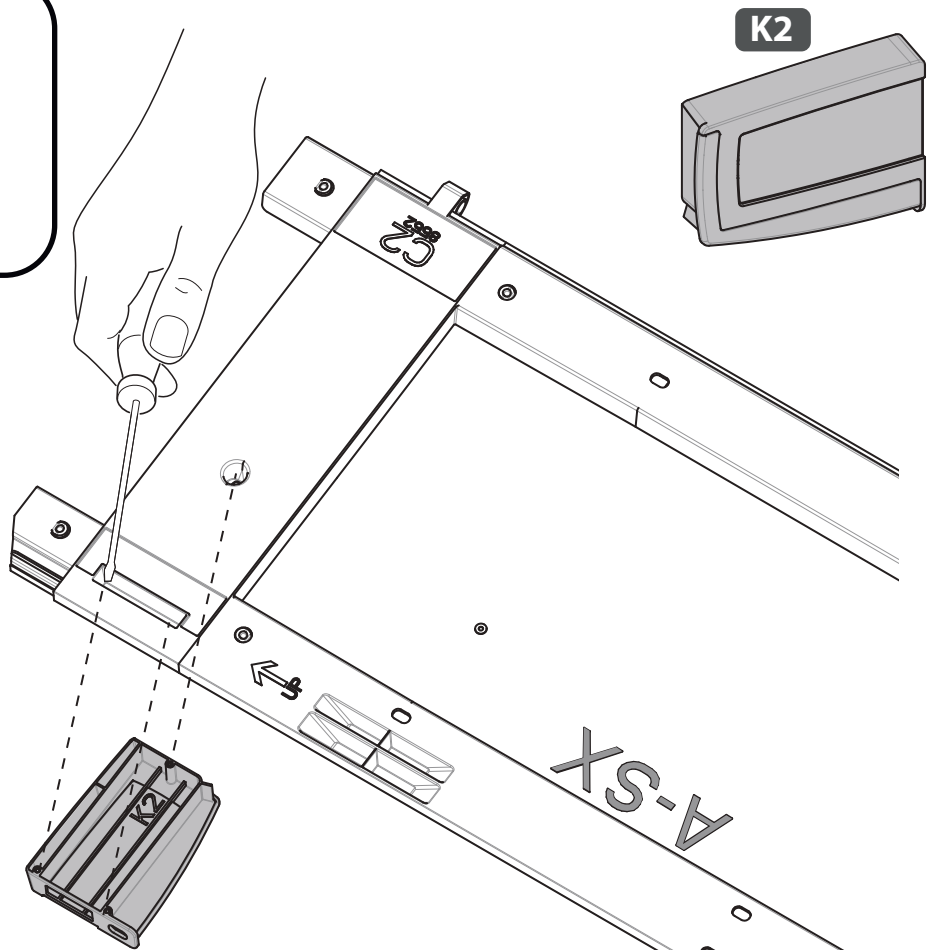

25

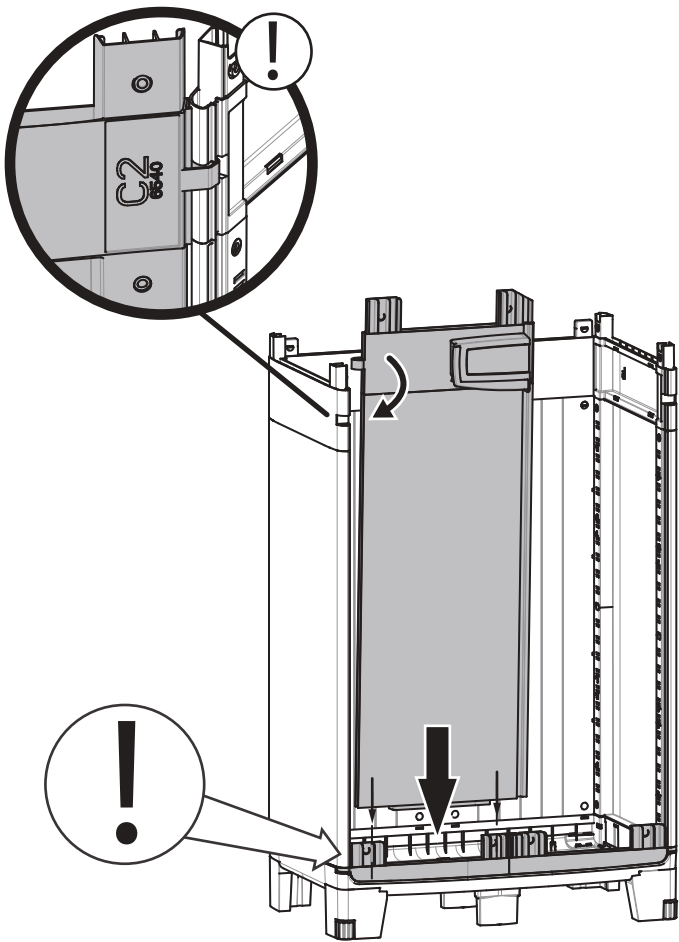

26

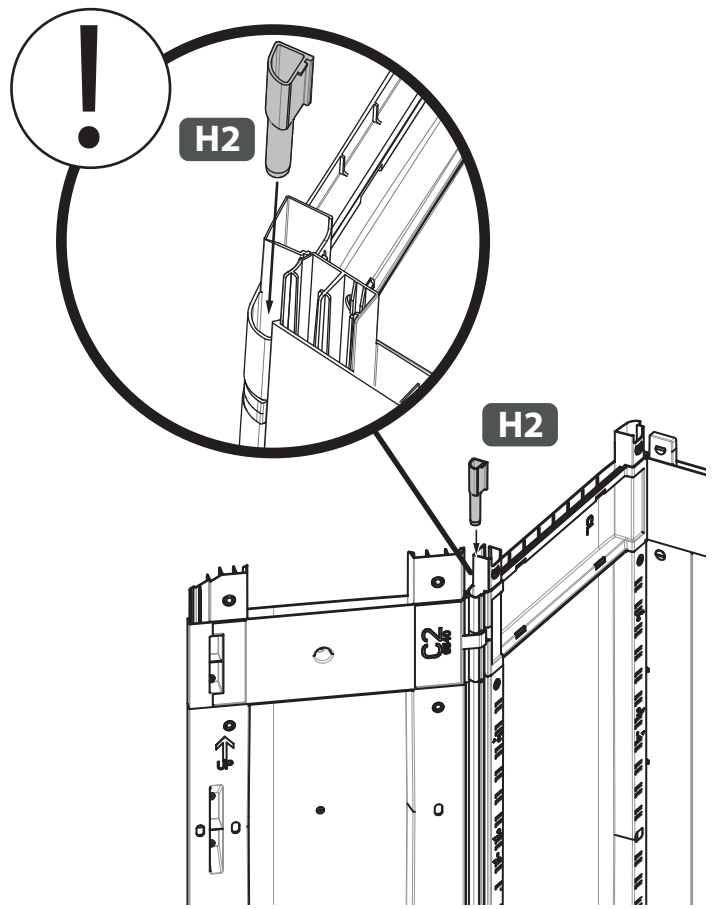

27

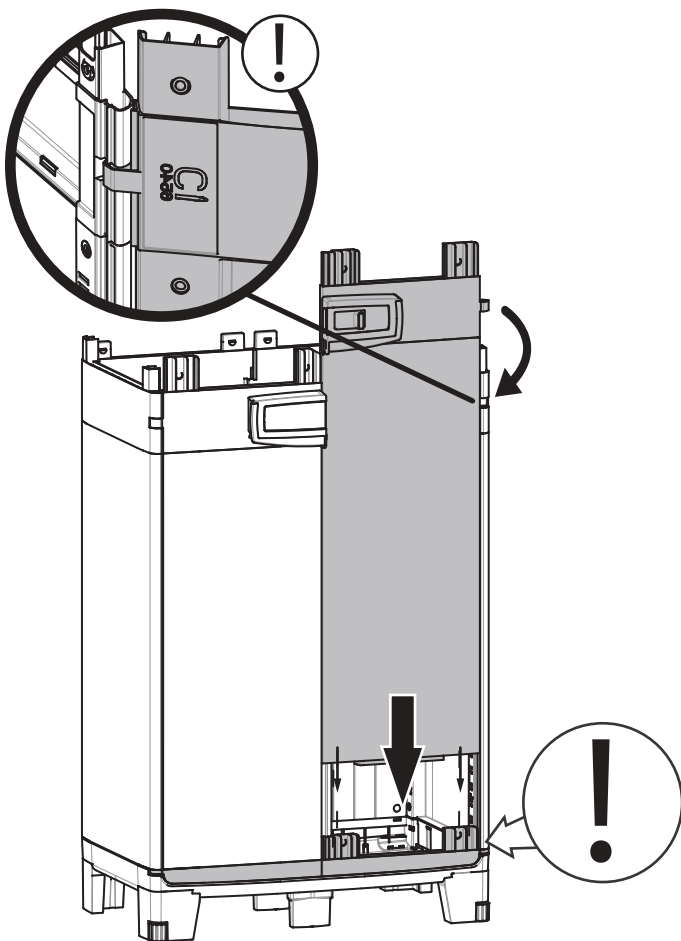

28

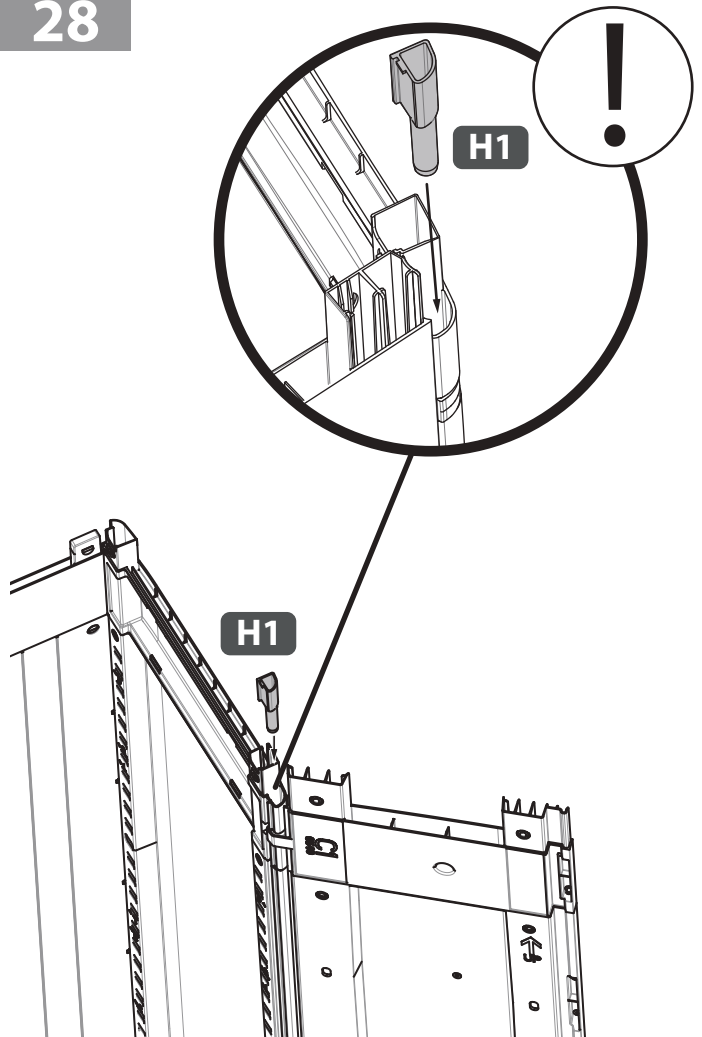

29



30

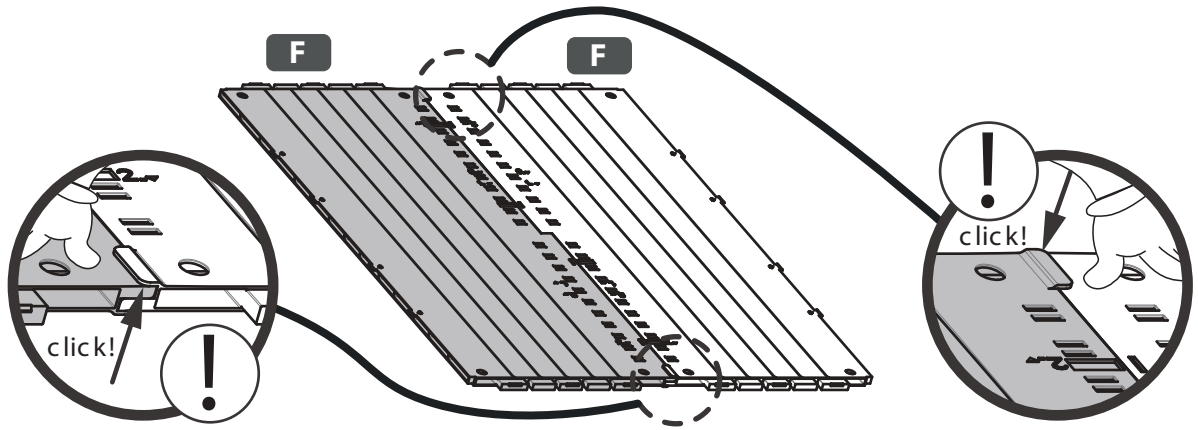

31

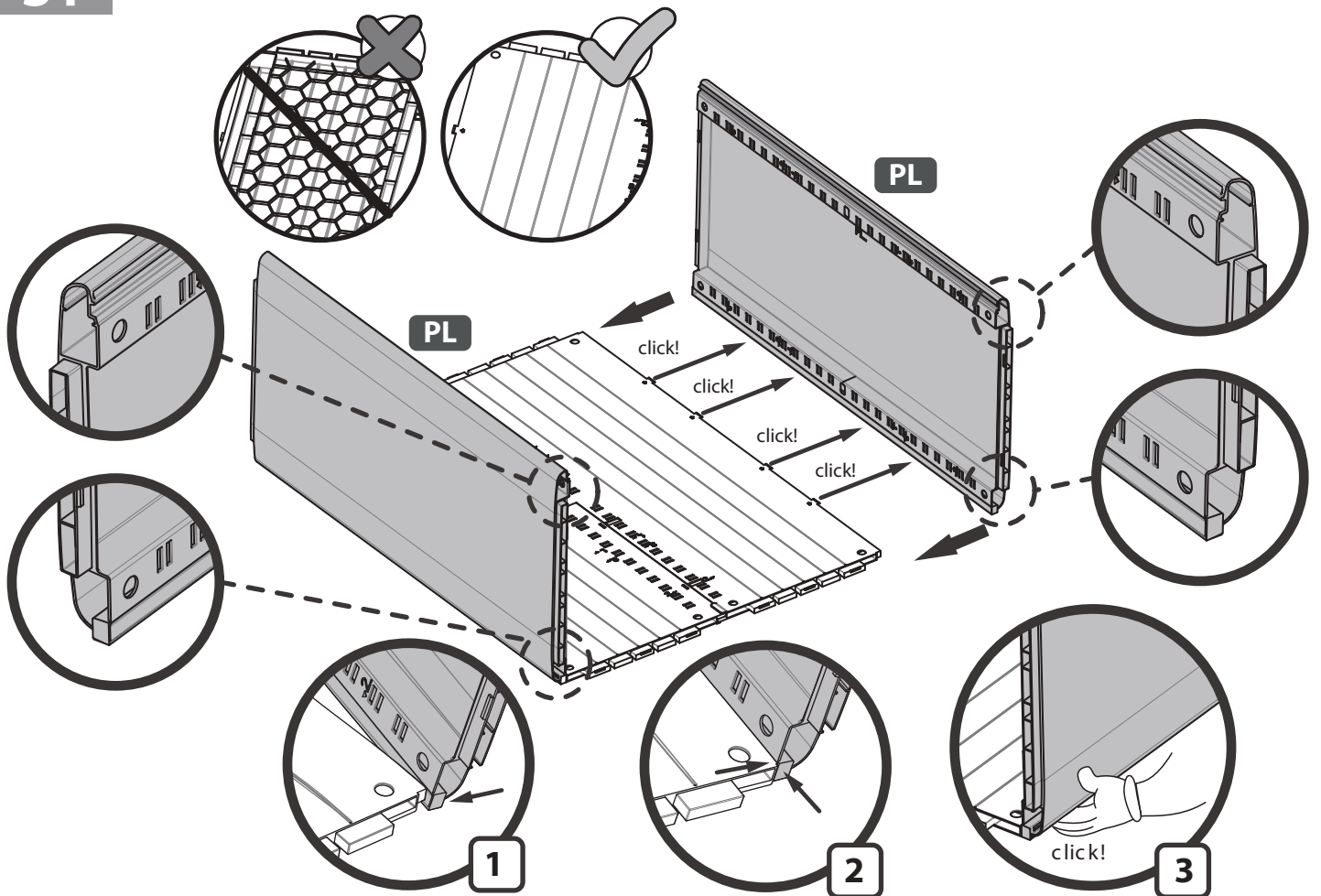

33

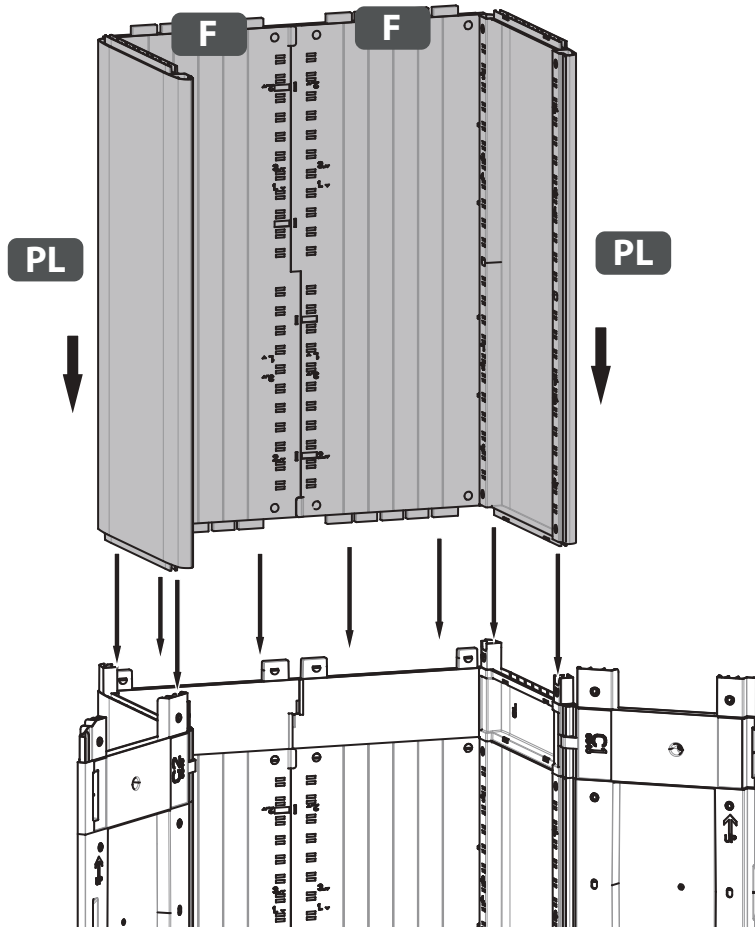

34

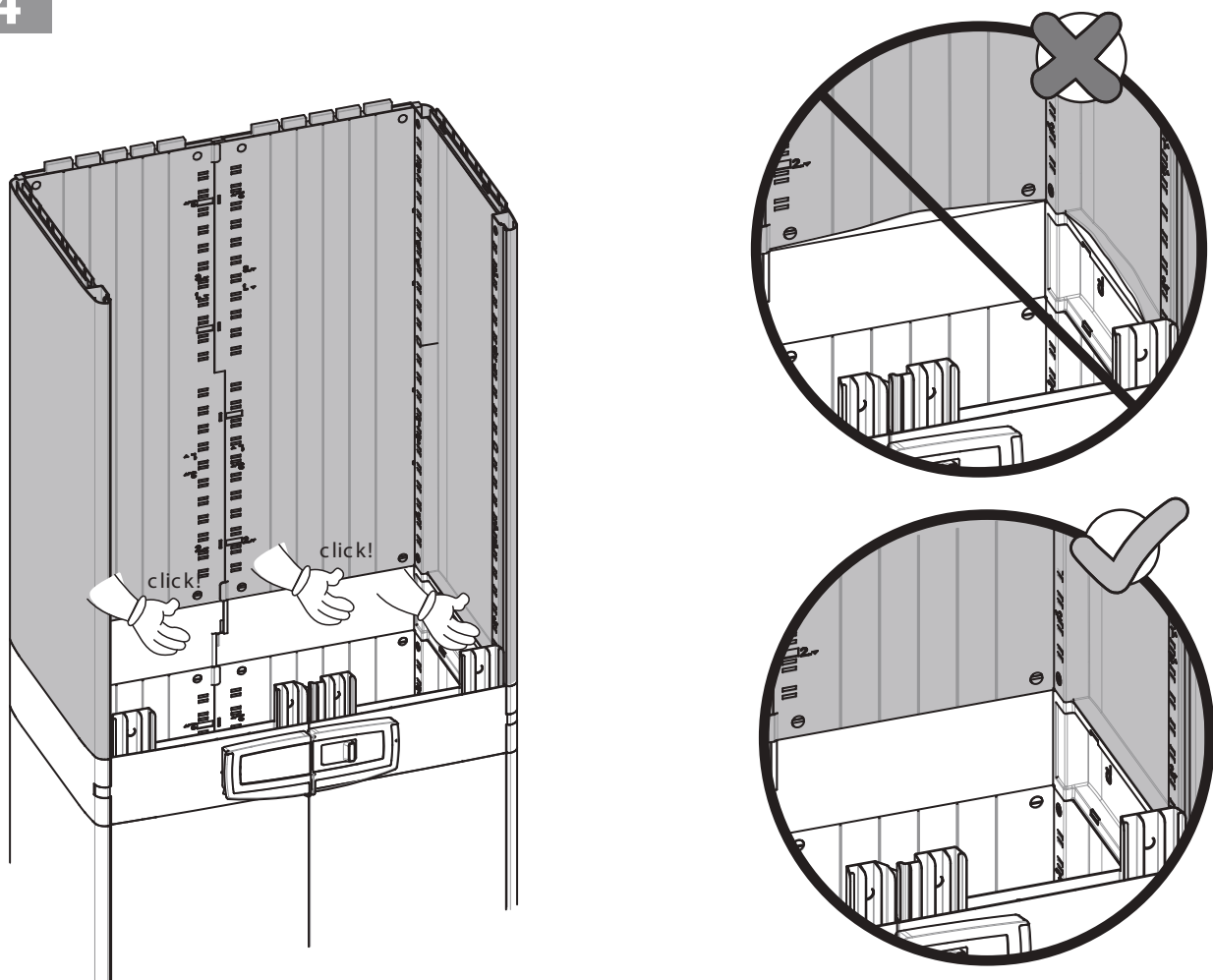

35

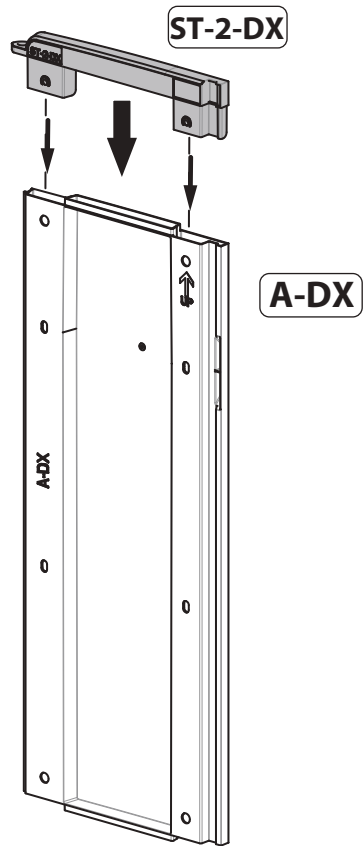
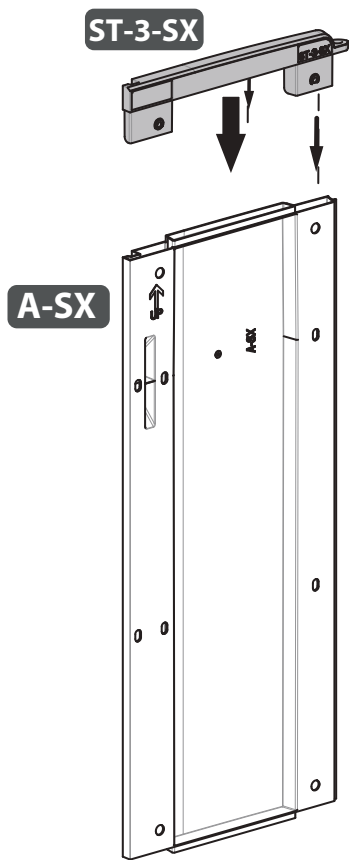

36

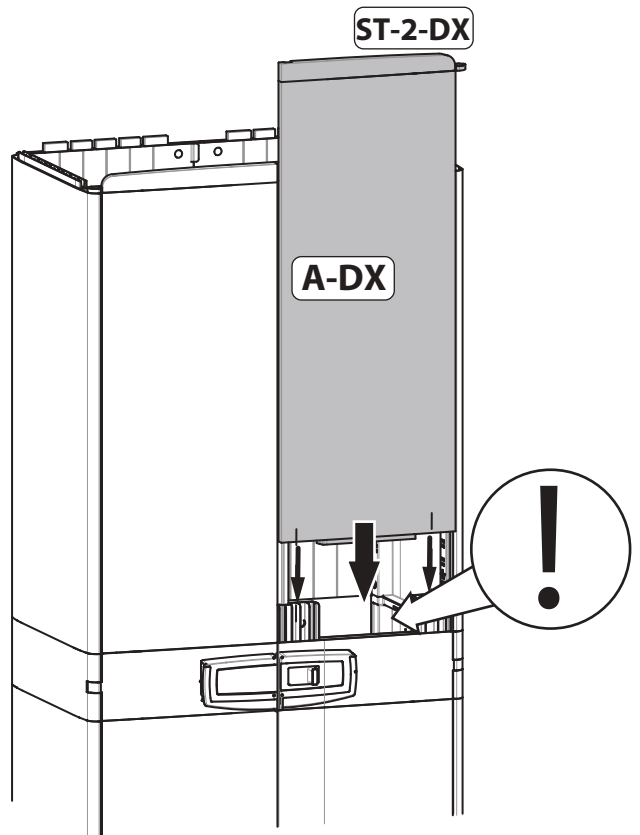
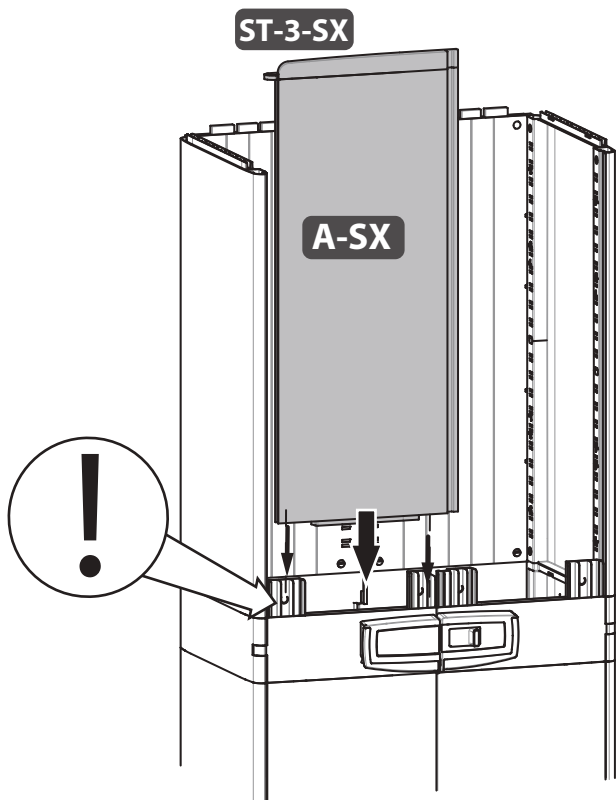

37

38



8:42

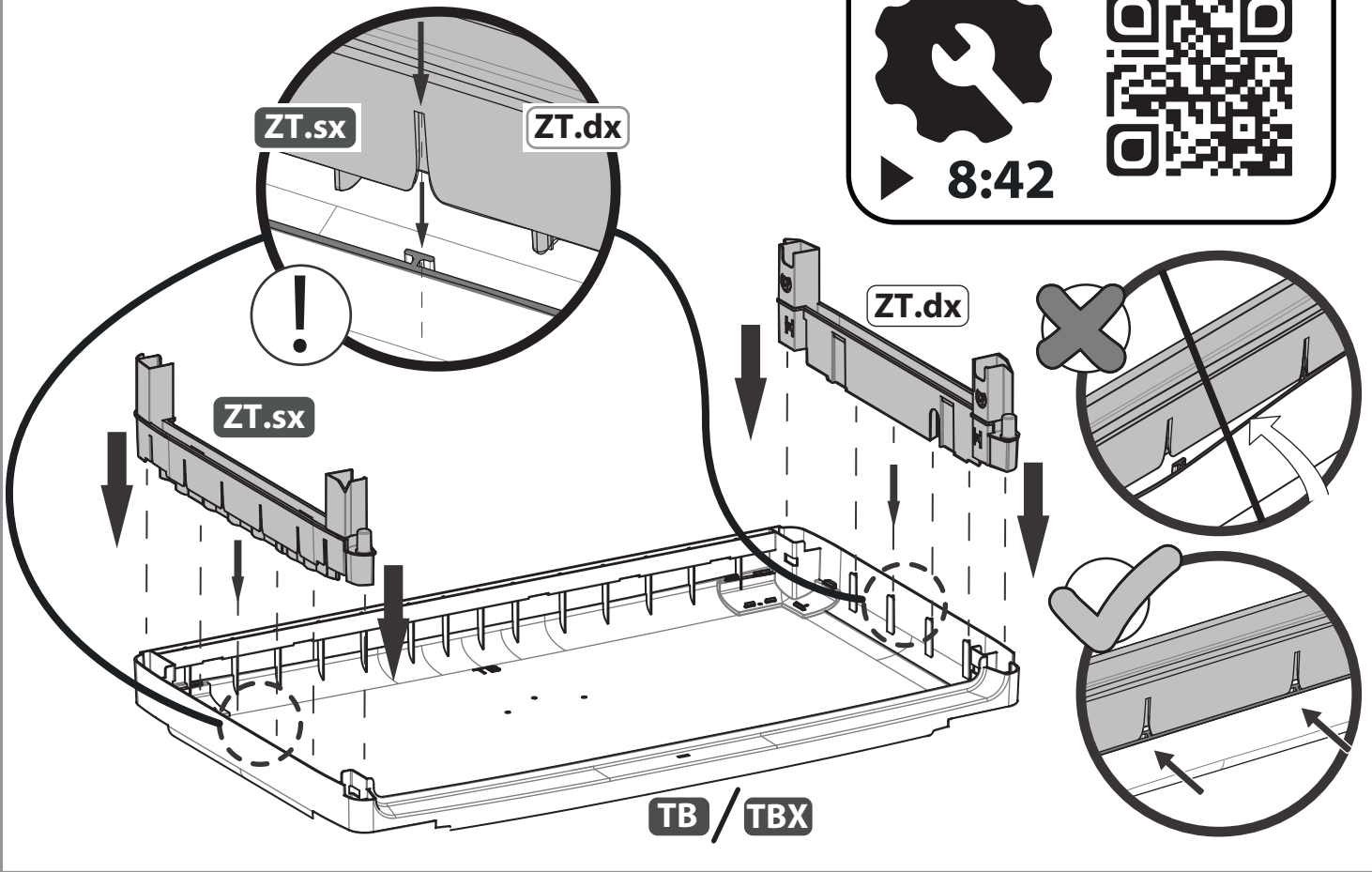

39

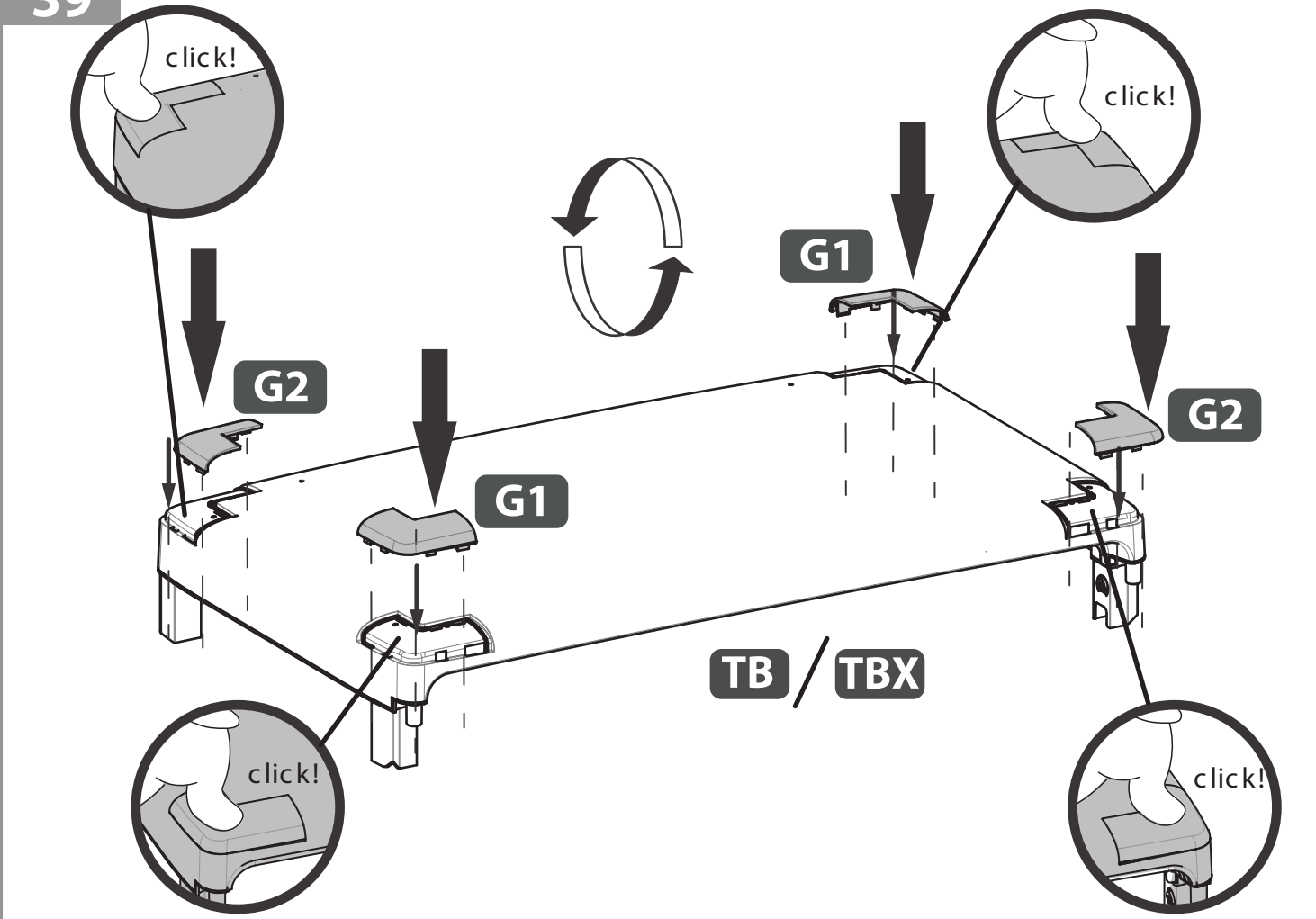



40

TB / TBX

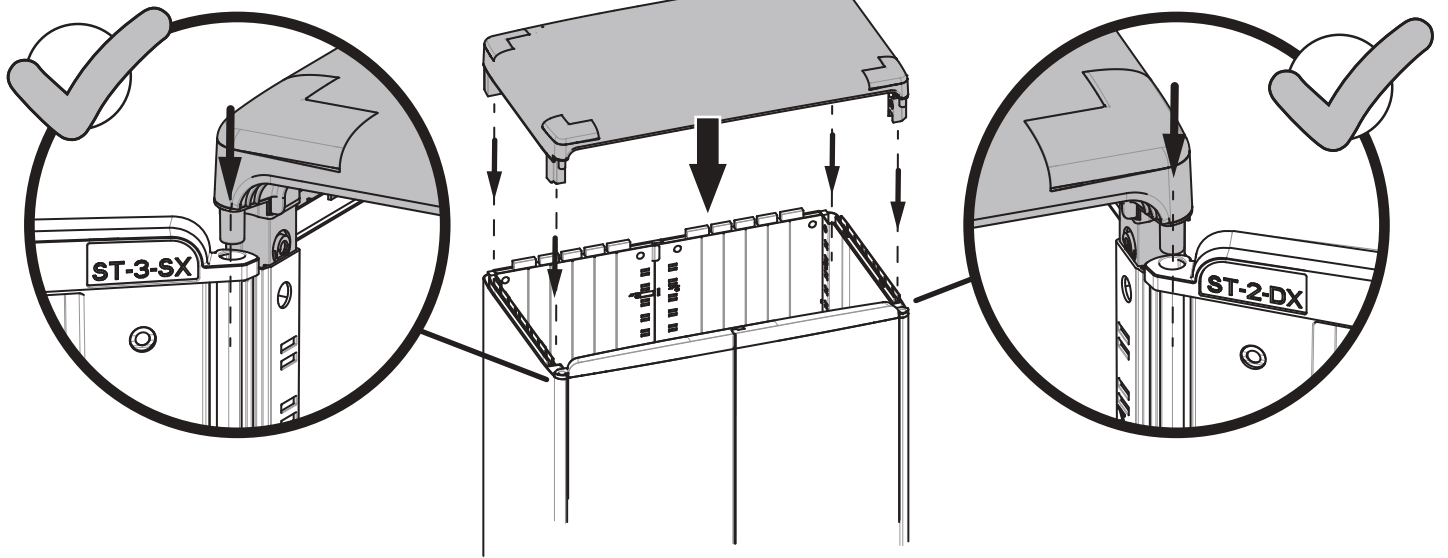

41

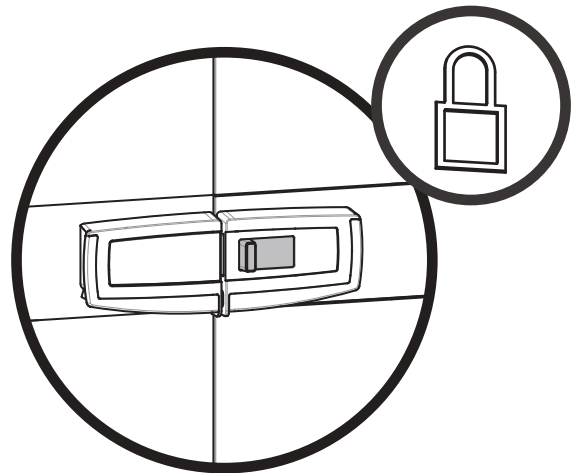
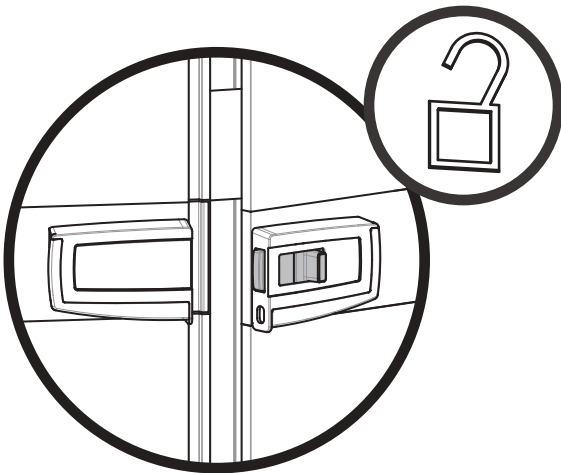
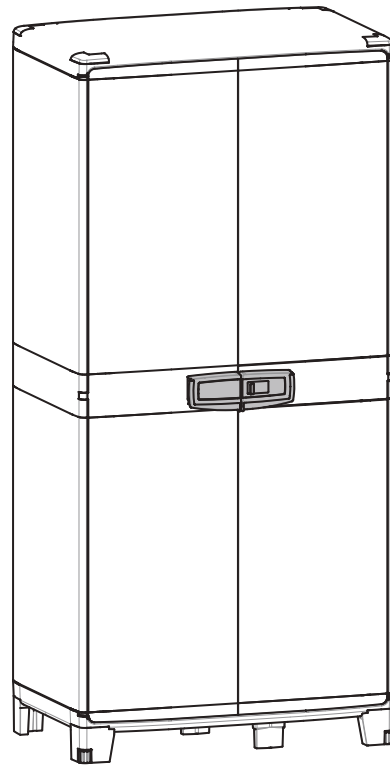
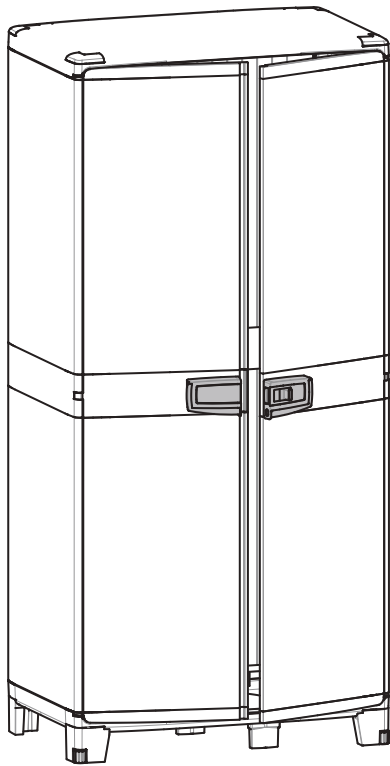

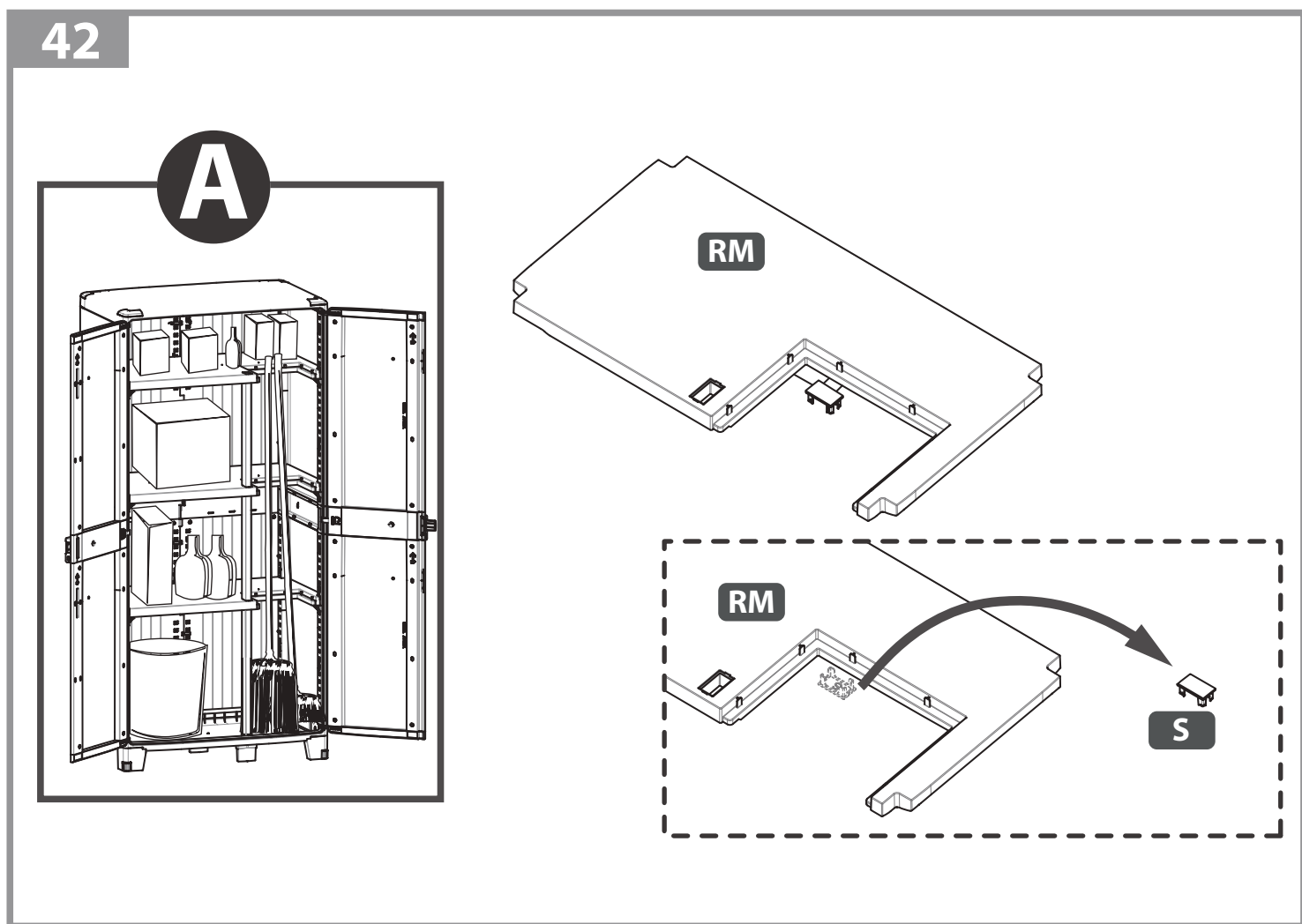
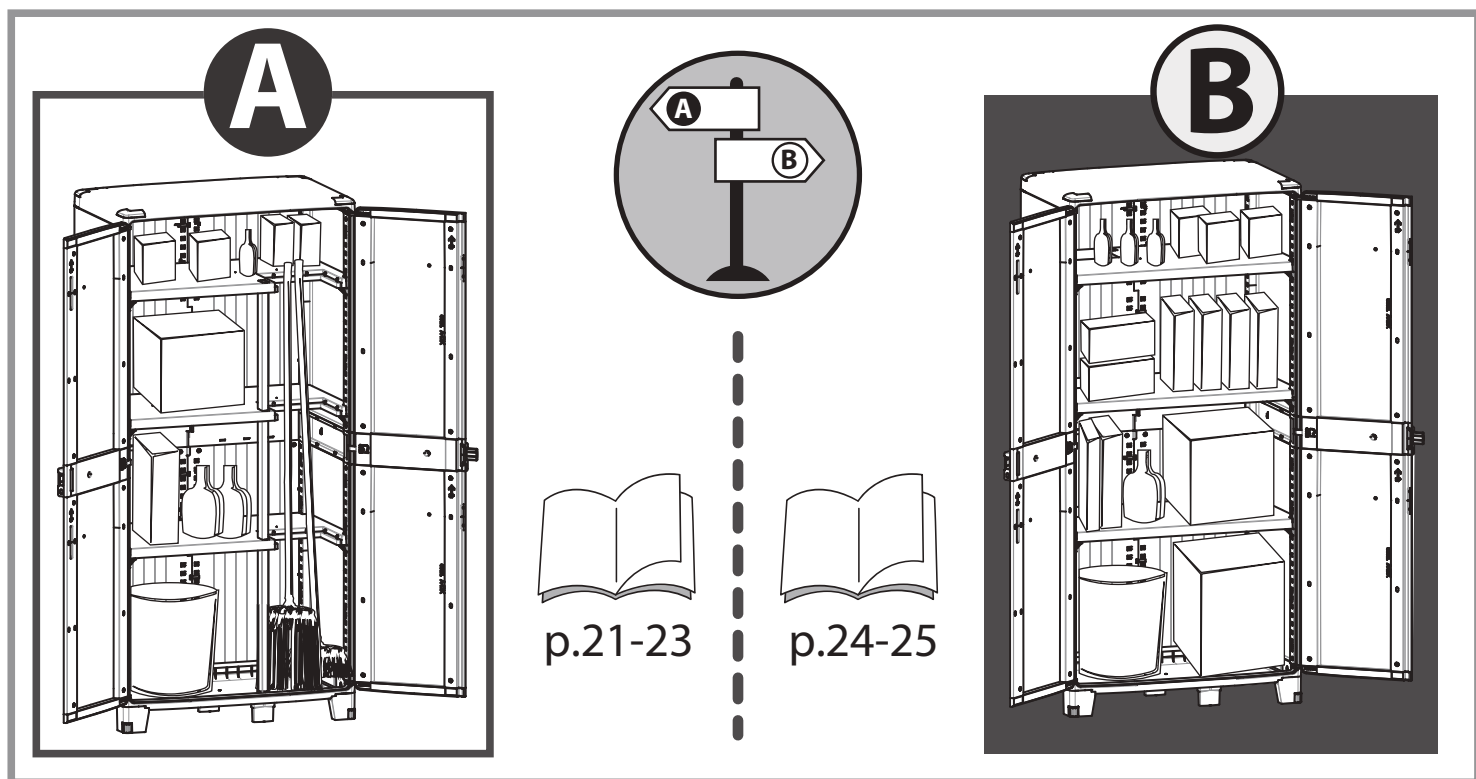



▶ 9:42

**A**

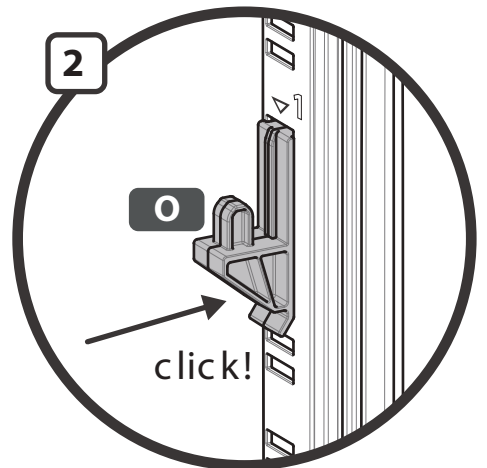
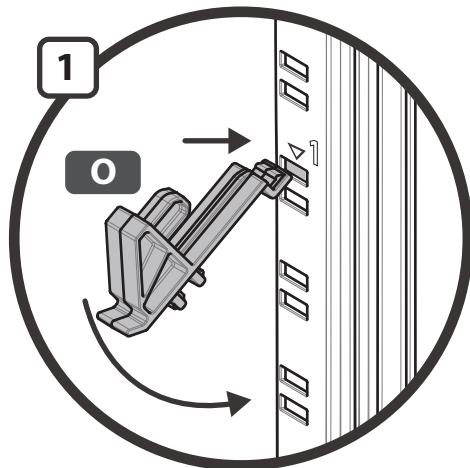
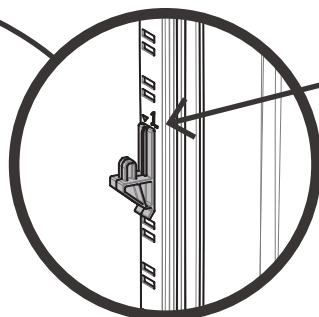
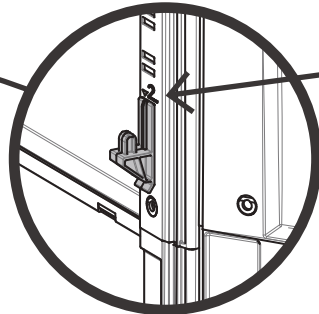
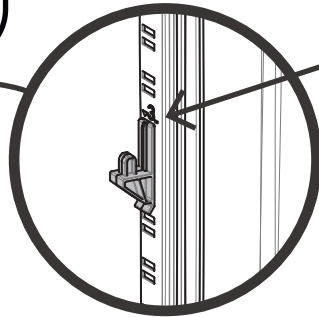
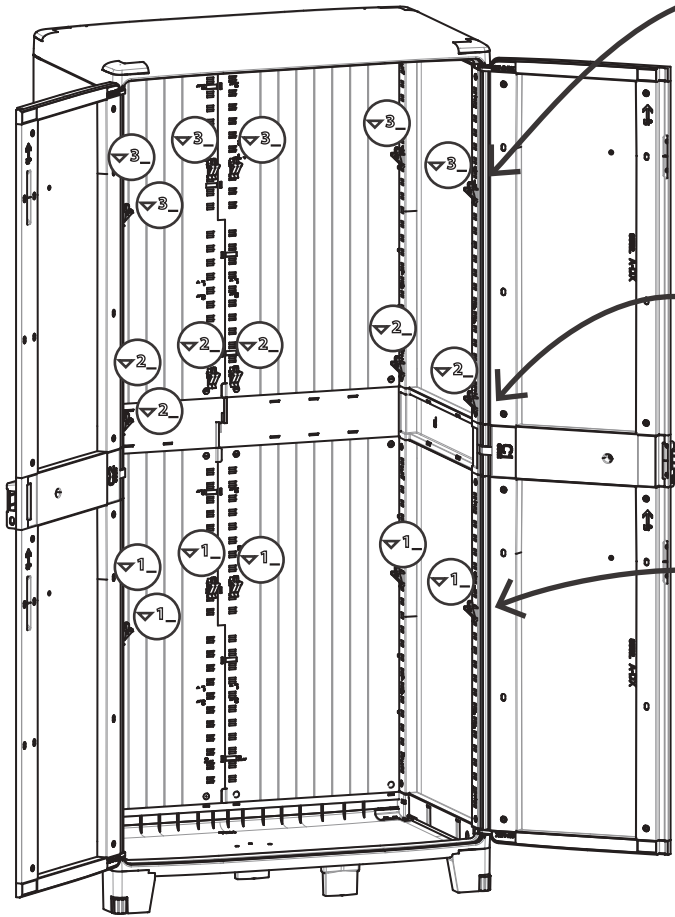

44

A

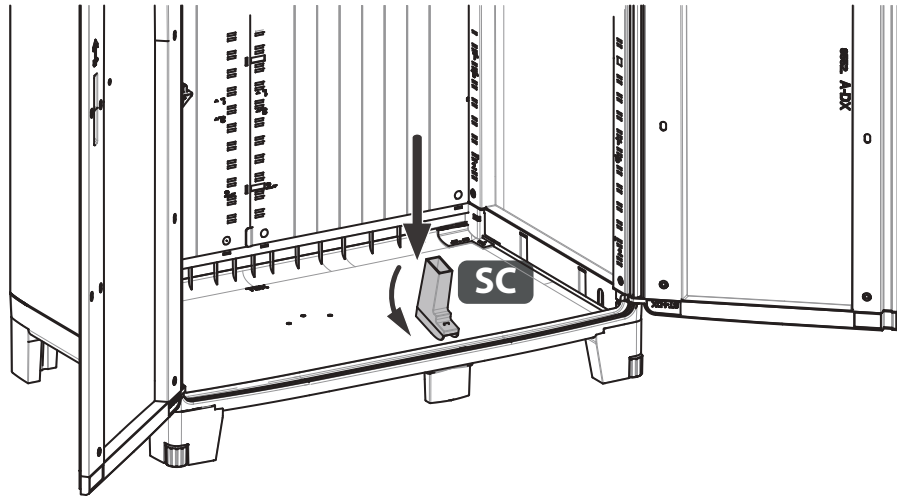

45

A

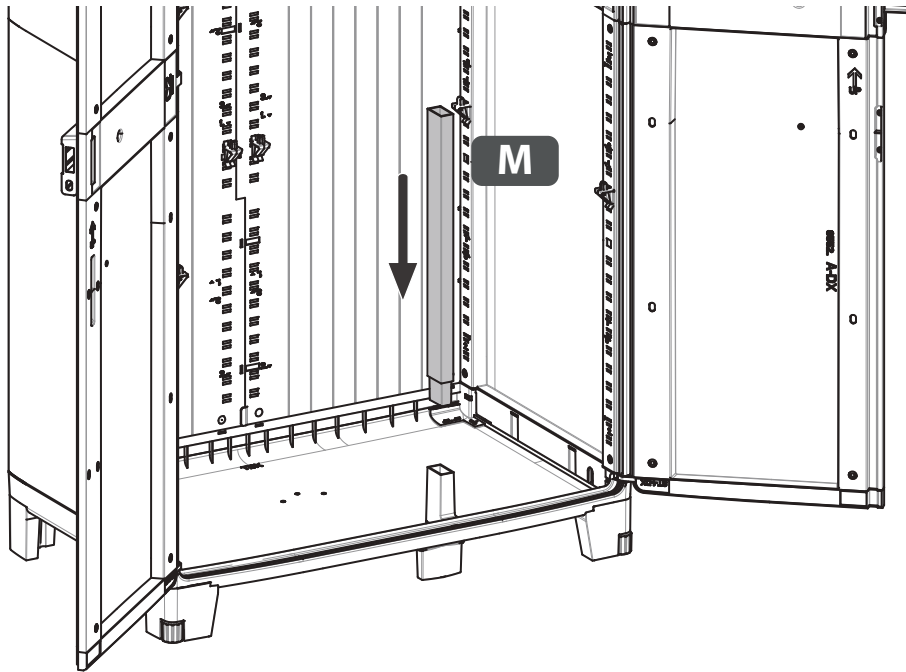

46

A

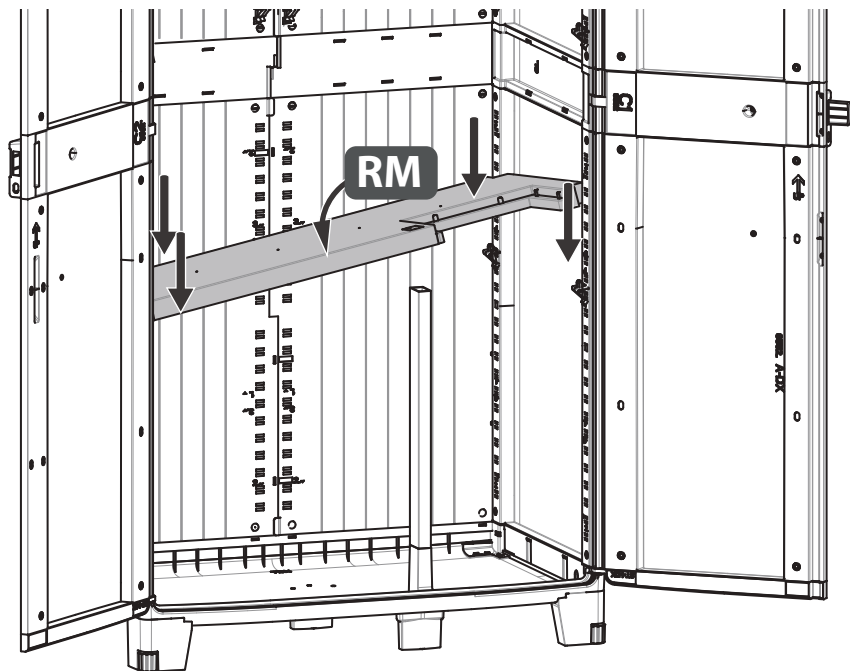

47

A

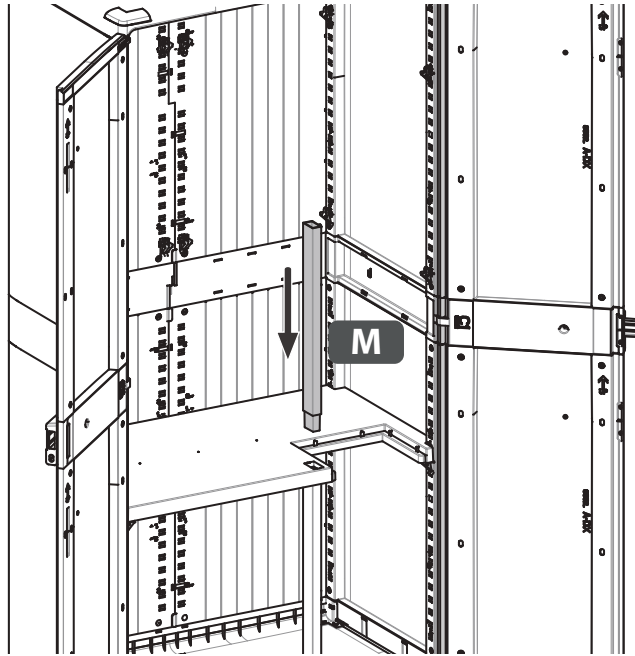

48

A

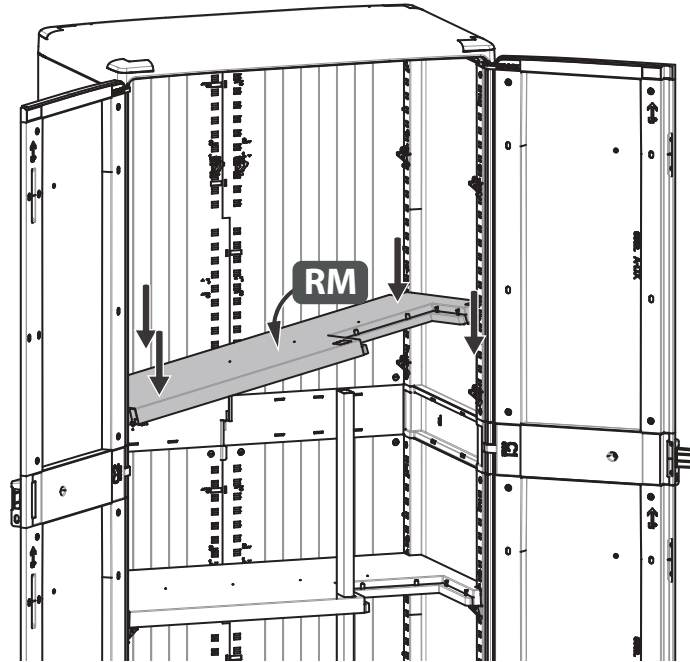

49

A

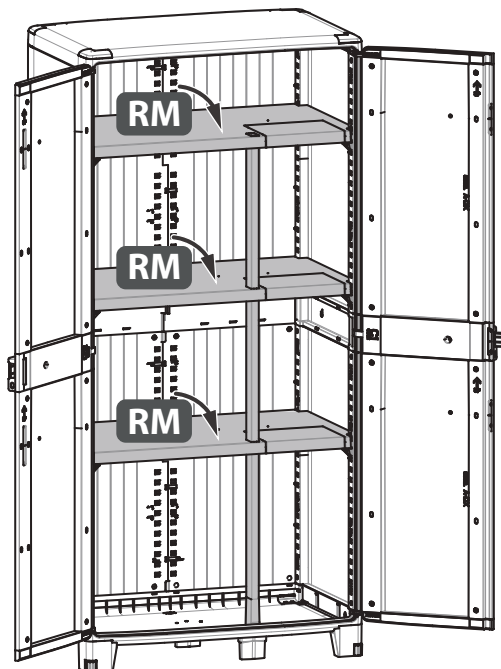

**B**

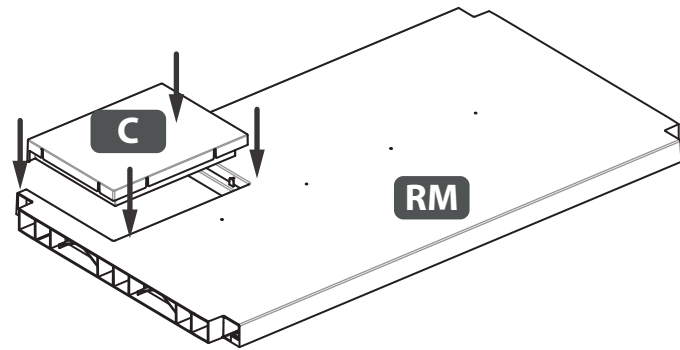
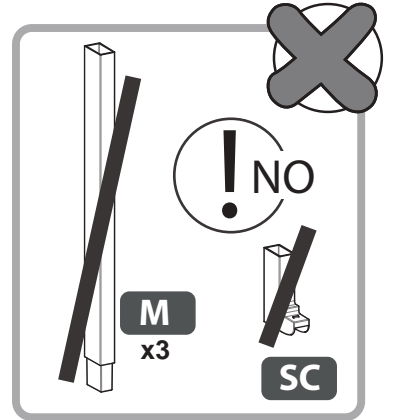
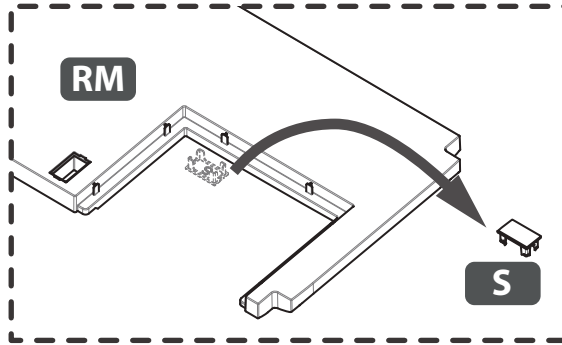
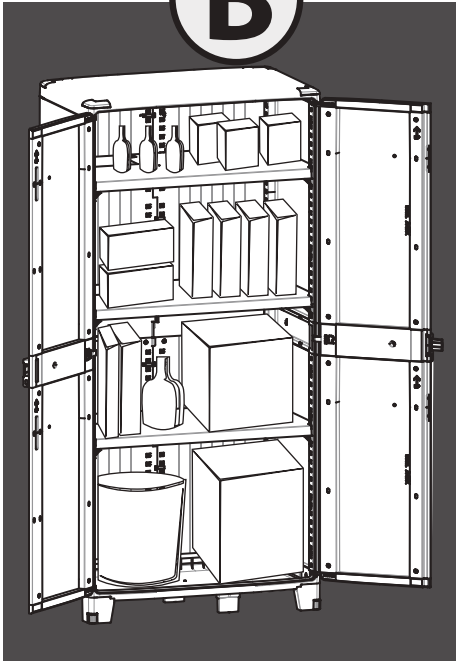

**B**

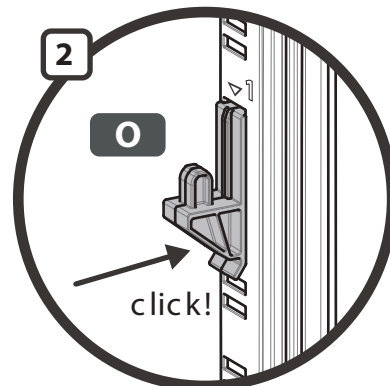
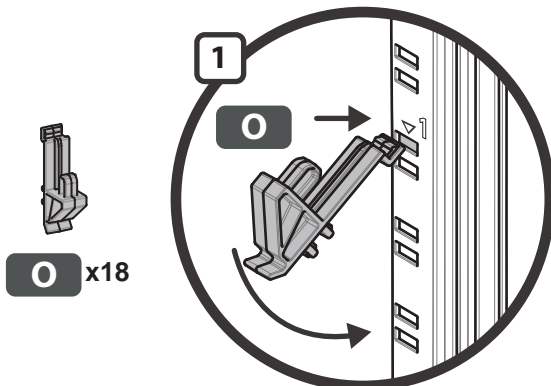
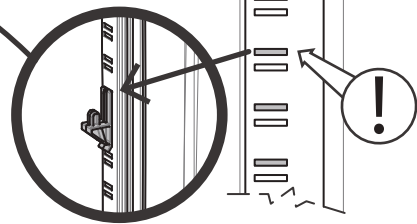
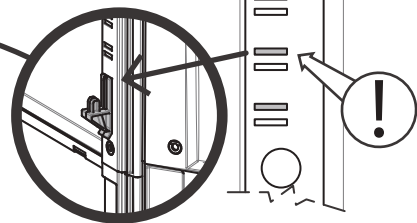
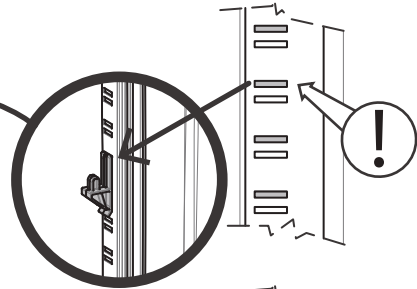
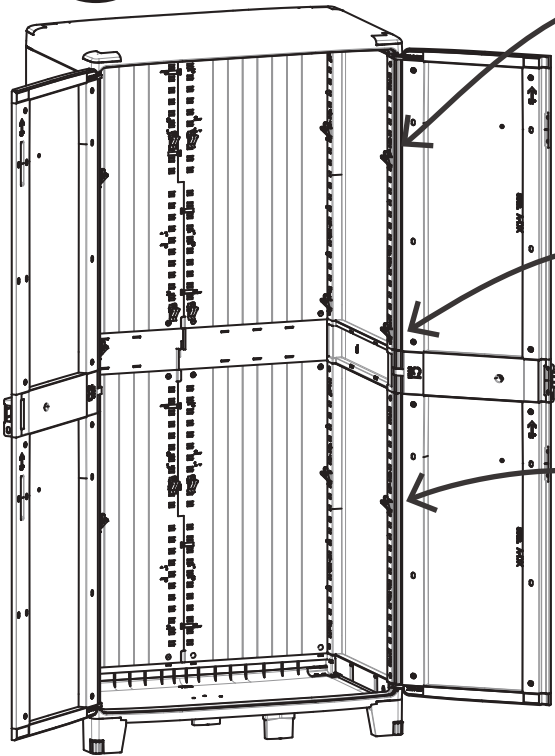

51

**B**

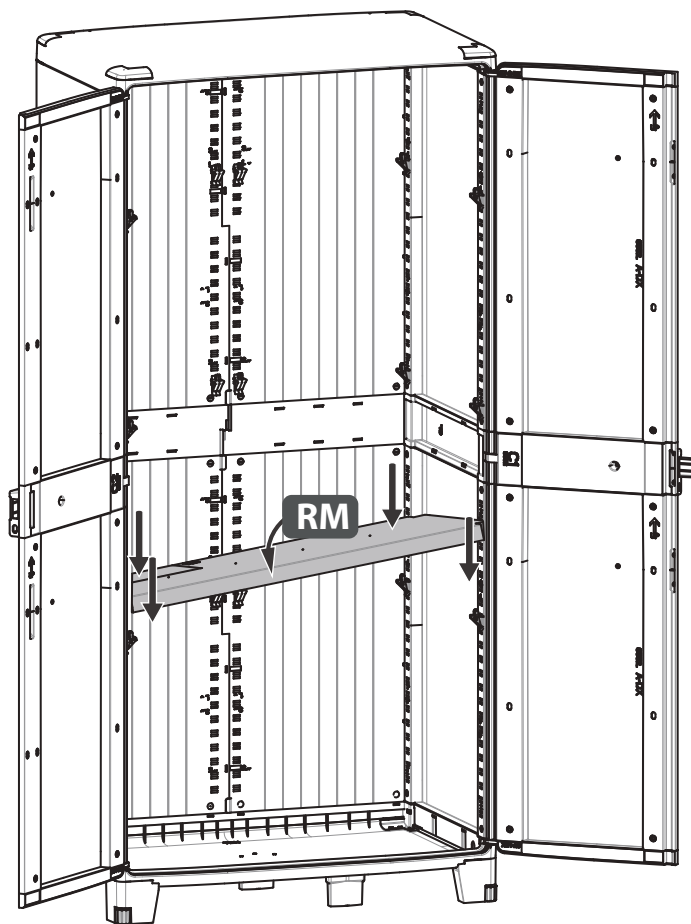

52

**B**

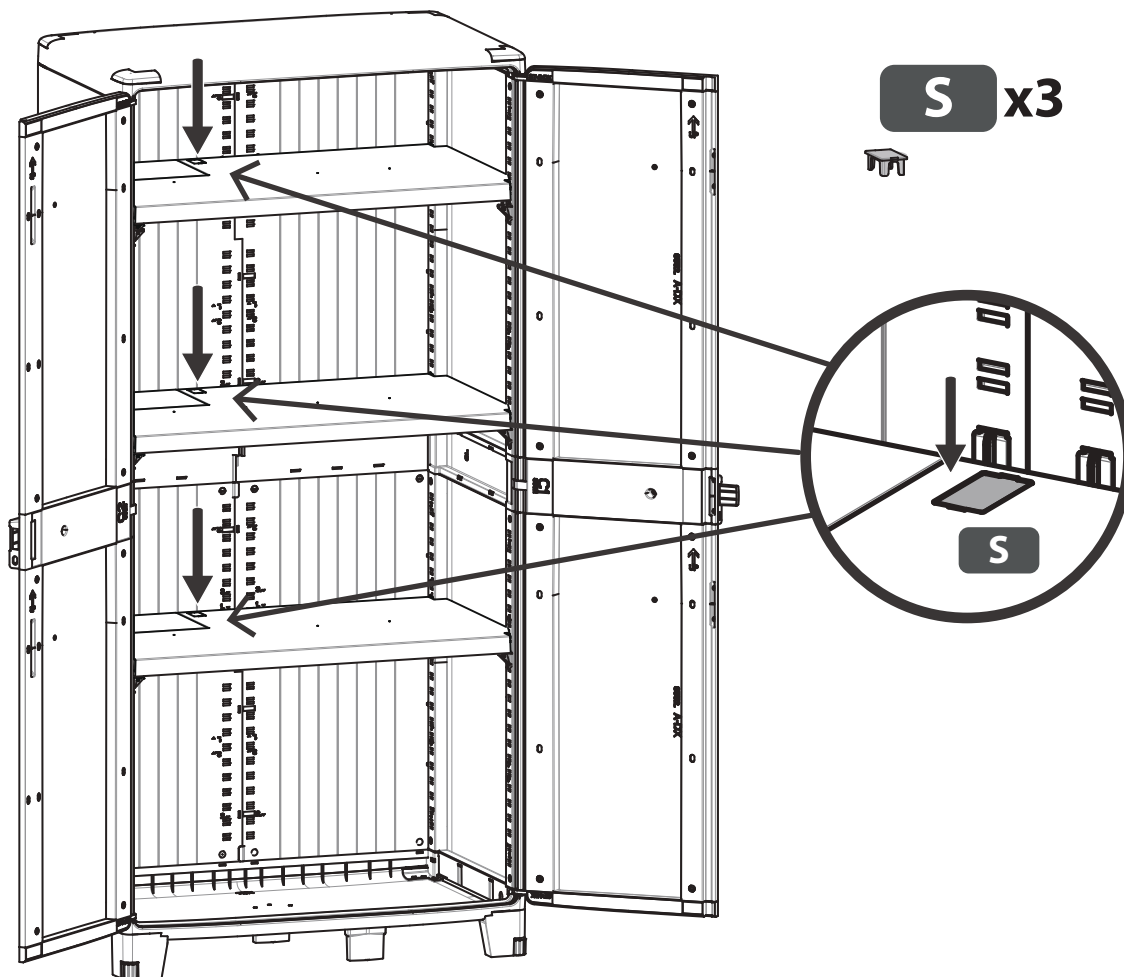



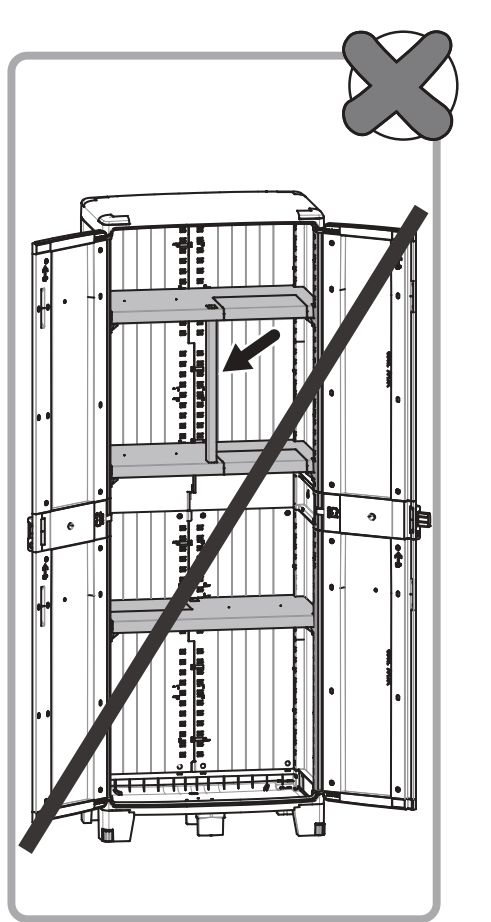
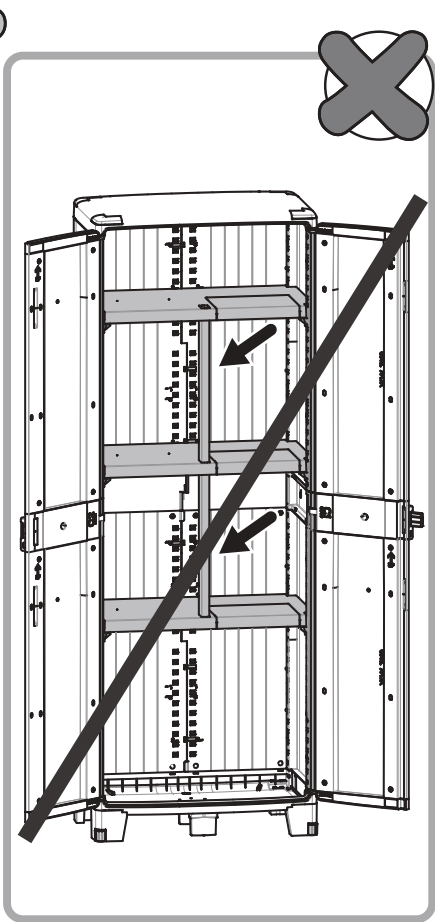
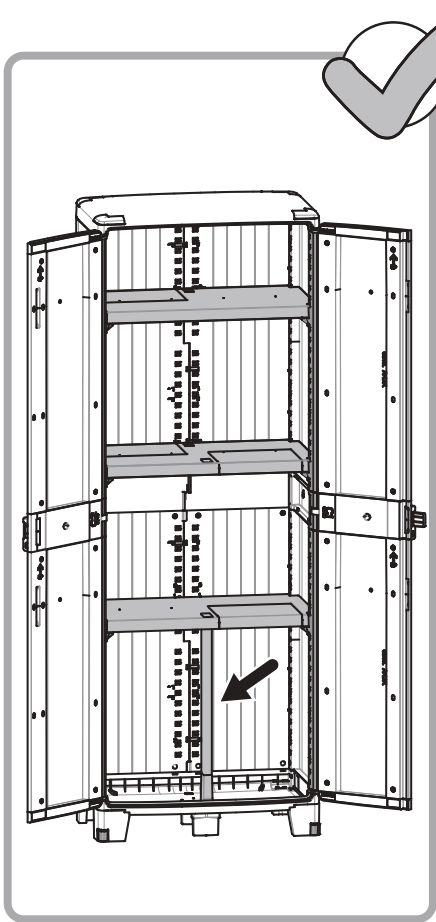
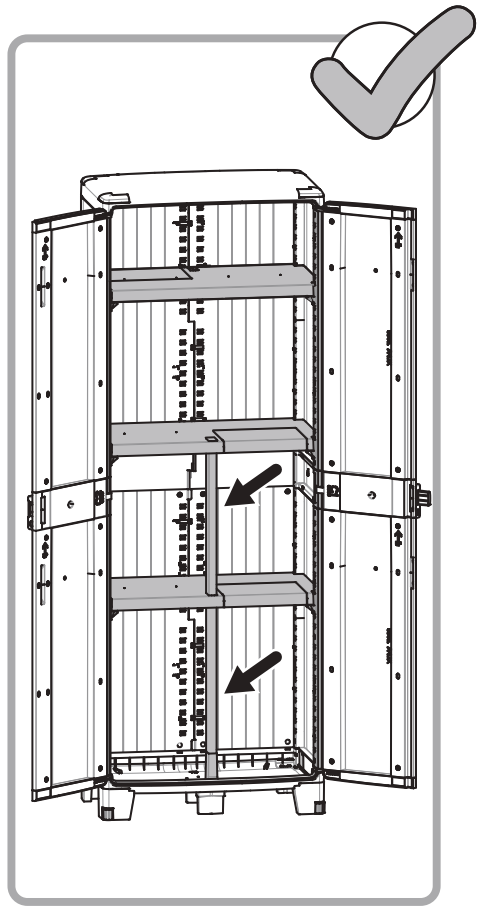
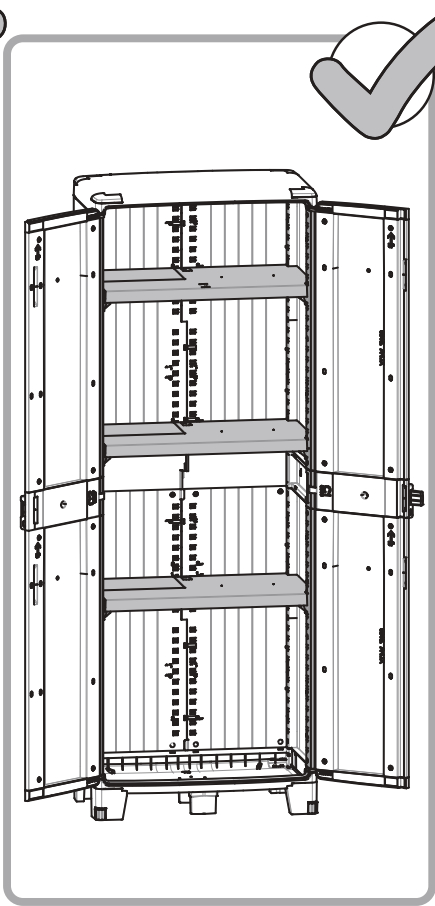
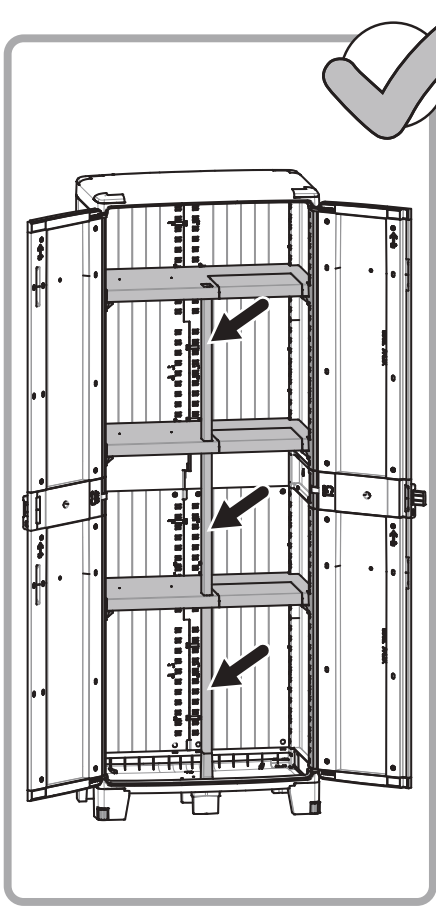

58

Sts

Sts



Sts x2



RS x2



VP x2

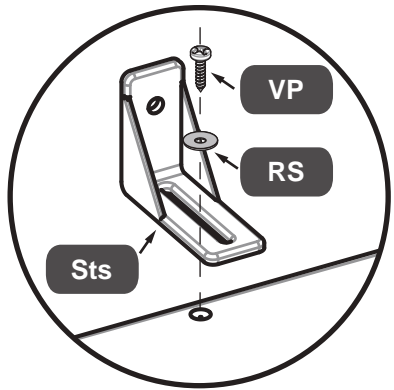
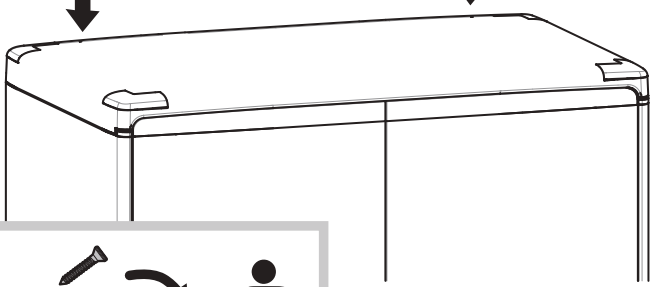

RS x2

VP x2



59

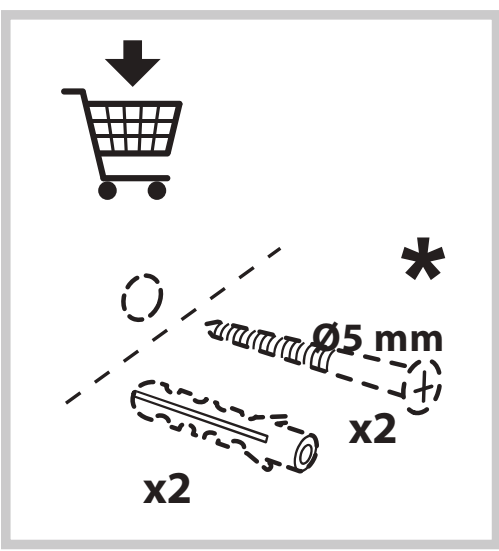
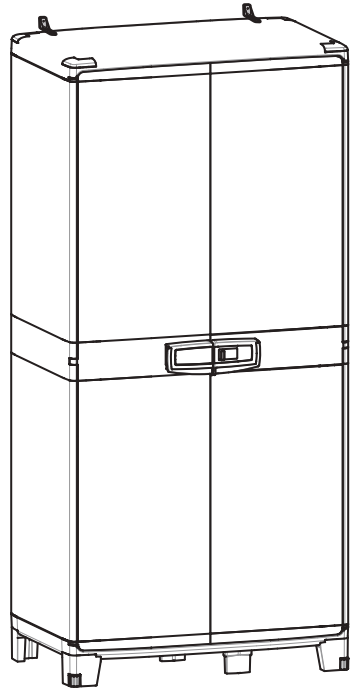

RS x2

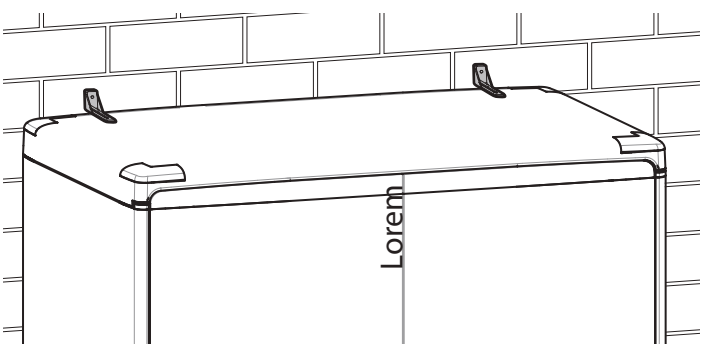
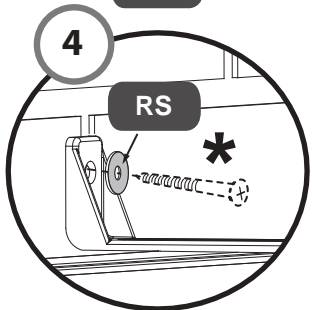
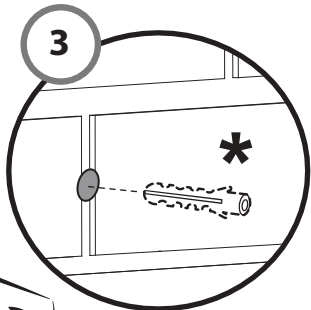
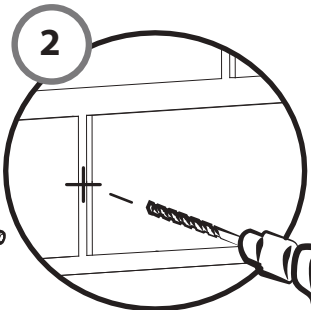
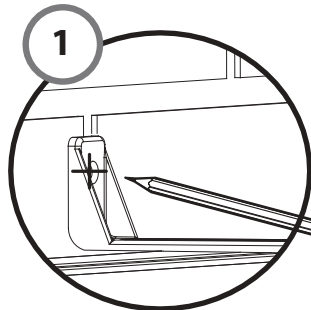



**FR / IMPORTANT, À CONSERVER POUR CONSULTATION ULTÉ-  
RIEURE : À LIRE ATTENTIVEMENT \_ES / IMPORTANTE, CONSERVAR PARA  
CONSULTAR POSTERIORMENTE: LEER ATENTAMENTE \_PT / IMPORTANTE  
CONSERVAR PARA FUTURAS CONSULTAS: POR FAVOR, LEIA COM ATEN-  
ÇÃO \_IT / IMPORTANTE, DA CONSERVARE PER ULTERIORE CONSULTA-  
ZIONE: DA LEGGERE ATTENTAMENTE \_EL / ΣΗΜΑΝΤΙΚΟ! ΚΡΑΤΗΣΤΕ ΤΟ  
ΓΙΑ ΜΕΛΛΟΝΤΙΚΗ ΑΝΑΦΟΡΑ. ΔΙΑΒΑΣΤΕ ΤΟ ΠΡΟΣΕΚΤΙΚΑ \_PL / WAŻNE,  
PRZECZYTAĆ UWAGNIE I ZACHOWAĆ NA PRZYSZŁOŚĆ \_RO / IMPORTANT,  
A SE PASTRA PENTRU CONSULTAREA ULTERIOARA: CITIȚI CU  
ATENȚIE \_EN / IMPORTANT, TO BE RETAINED FOR FUTURE REFERENCE:  
PLEASE READ CAREFULLY**



**Ce meuble se recycle,  
s'il n'est plus utilisable  
déposez-le en déchèterie.**

**Pour en savoir plus :  
[www.quefairedemesdechets.fr](http://www.quefairedemesdechets.fr)**

- ES** Si ya no puede utilizarse, este mueble se puede reciclar, deposítelo en la unidad de clasificación de residuos.
- PT** Este móvel é reciclável. Quando deixar de ser utilizado, deposite-o num centro de reciclagem de resíduos.
- IT** Questo mobile può essere riciclato, portatelo in un'isola ecologica se inutilizzabile.
- EL** Το έπιπλο αυτό είναι ανακυκλώσιμο, εάν δεν μπορεί πλέον να χρησιμοποιηθεί τοποθετήστε το σε χώρο αποβλήτων.
- PL** Mebel ten poddawany jest recyklingowi, kiedy przestaje być użyteczny należy go dostarczyć do punktu zbiórki odpadów.
- RO** Această piesă de mobilier este reciclabilă. Dacă nu mai poate fi folosită, vă rugăm să o duceți la centrul de reciclare a deșeurilor.
- EN** This piece of furniture is recyclable. If it cannot be used anymore, please take it to the waste recycling centre.

**FR** \* Garantie 7 ans.

**ES** \* Garantía 7 años

**PT** \* Garantia 7 anos

**IT** \* Garanzia 7 anni

**EL** \* Εγγύηση 7 ετών

**PL** \* Gwarancja 7 lat

**RO** \* Garanție 7 ani

**EN** \* Guarantee 7 years

ADEO Services - 135 Rue Sadi Carnot - CS00001  
59790 RONCHIN - FRANCE



Imported by Adeo South Africa (PTY) LTD T/A Leroy Merlin,  
Hosted in Leroy Merlin Fourways Store 35 Roos Street, Witkoppen Ext 97, Sandton  
2191 Johannesburg, Gauteng, South Africa  
Tel: +27 10 493 8000 Email: [contact@leroymerlin.co.za](mailto:contact@leroymerlin.co.za)



<https://quefairedemesdechets.fr>

