

FR	PLAN DE LA NOTICE
ES	Plano de las instrucciones
PT	Plano de instruções
IT	Piano delle istruzioni
EL	Σχέδιο οδηγιών
PL	Plan instrukcji
RO	Planul instructiunilor
EN	Plan of the instructions

01

FR	Matériel
ES	Equipo
PT	Equipamento
IT	Attrezzatura
EL	Εξοπλισμός
PL	Ekwipunek
RO	Echipamente
EN	Equipment



02

FR	Sécurité et entretien
ES	Seguridad y mantenimiento
PT	Segurança e manutenção
IT	Sicurezza e manutenzione
EL	Ασφάλεια και συντήρηση
PL	Bezpieczeństwo i konserwacja
RO	Siguranță și întreținere
EN	Safety and maintenance



03

FR	Montage
ES	Montaje
PT	Conjunto
IT	Assemblea
EL	Συνέλευση
PL	Lontaż
RO	Asamblare
EN	Assembly



FR	Important, à conserver pour consultation ultérieure : à lire attentivement
ES	Importante, conservar para consultar posteriormente: leer atentamente
PT	Importante, conservar para futuras consultas: por favor, leia com atenção
IT	Importante, da conservare per ulteriore consultazione: da leggere attentamente
EL	Σημαντικό, κρατήστε για μελλοντική αναφορά: να διαβάσετε προσεκτικά
PL	Ważne, zachowaj na przyszłość: czytać uważnie
RO	Important, păstrați pentru referințe viitoare: sa citească cu atenție
EN	Important, to be retained for future reference: please read carefully

01

FR MATÉRIEL
 ES Equipo
 PT Equipamento
 IT Attrezzatura
 EL Εξοπλισμός
 PL Plan instrukcji
 RO Planul instructiunilor
 EN Equipment

FR N'utilisez pas de cutter pour ouvrir les films plastique
 ES No utilice un cúter para abrir el plástico protector
 PT Não utilize um cortador para abrir os filmes de plástico protetores
 IT Non utilizzare un taglierino per aprire le pellicole da imballaggio
 EL Μη χρησιμοποιείτε κοπίδι για να ανοίξετε τις πλαστικές μεμβράνες
 PL Nie używaj noża/ noża technicznego do otwierania plastikowych folii
 RO Nu folosiți un cutter pentru a deschide foliile de plastic
 EN Do not use a cutter to open the plastic films

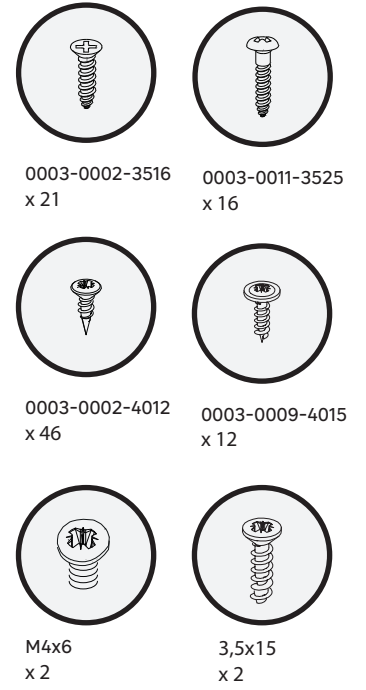
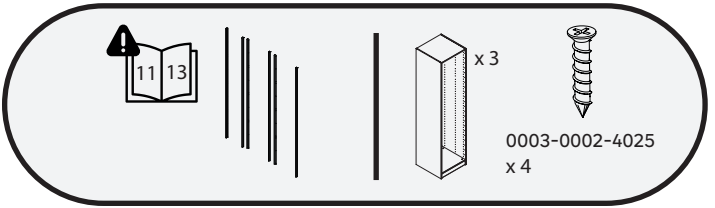
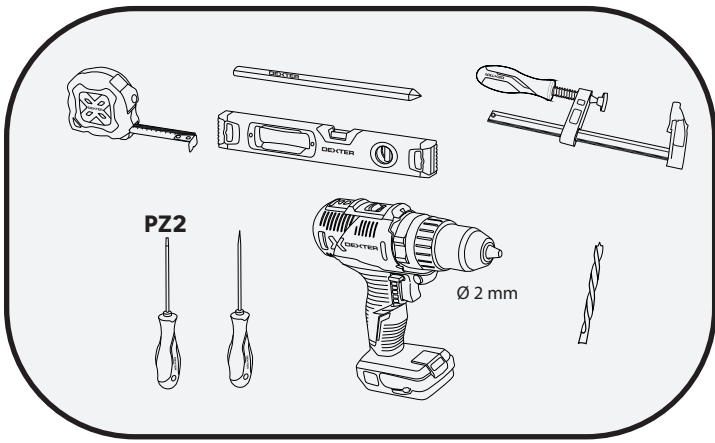
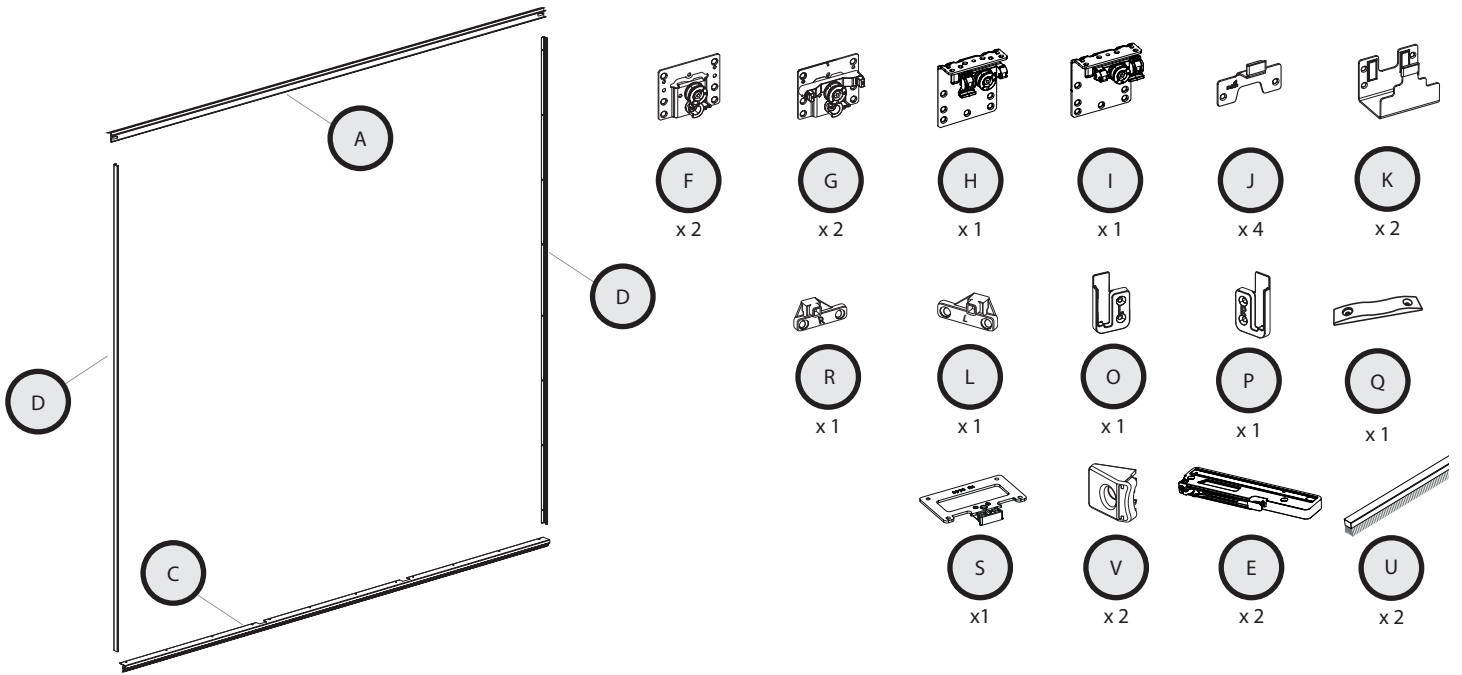

02

SÉCURITÉ ET ENTRETIEN

FR
ES
PT
IT
EL
PL
RO
EN

Seguridad y mantenimiento

Segurança e manutenção

Sicurezza e manutenzione

Ασφάλεια και συντήρηση

Bezpieczeństwo i konserwacja

Siguranță și întreținere

Safety and maintenance

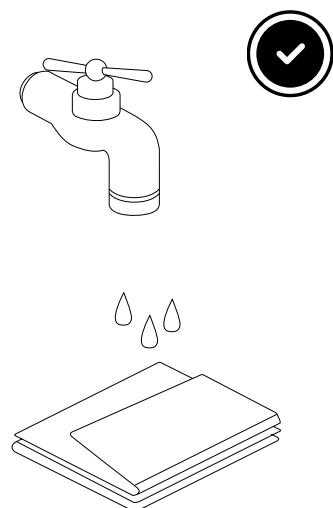
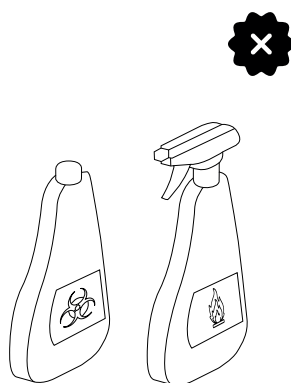
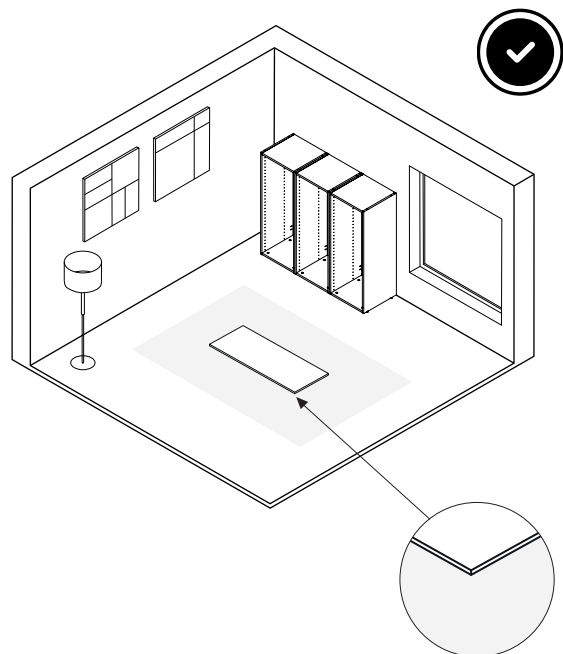
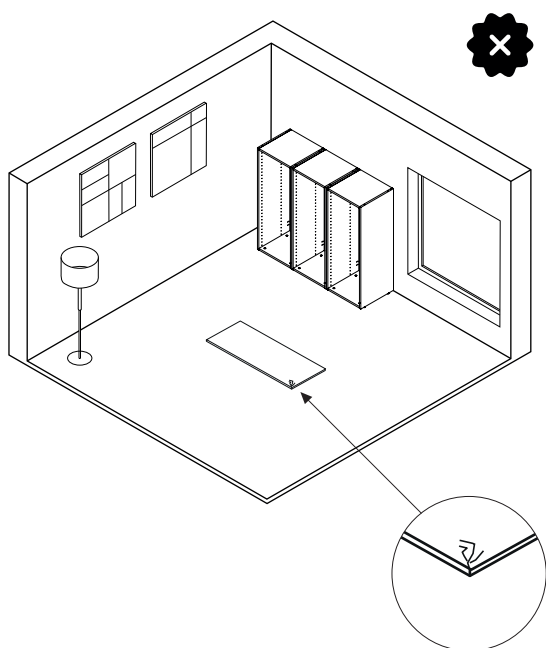

03

MONTAGE

FR Montaje
ES Conjunto
PT Assembla
IT Συνέλευση
EL Lontaž
RO Asamblare
EN Assembly

FR Si vous avez des portes coulissantes à installer sur le caisson, le montage avec plinthes est requis
ES Si tiene puertas correderas para instalar en el gabinete, se requiere el montaje con zócalos
PT Se você tiver portas de correr para serem instaladas no gabinete, é necessária a montagem com rodapés
IT Se si hanno ante scorrevoli da installare sull'armadio, è necessario il montaggio con zoccoli
EL Εάν έχετε συρόμενες πόρτες για εγκατάσταση στο ντουλάπι, απαιτείται τοποθέτηση με πλίνθους
PL Jeśli masz drzwi przesuwne do zamontowania na szafce, wymagany jest montaż z cokotami
RO Dacă aveți uși glisante de montat pe dulap, este necesară montarea cu plinte
EN If you have sliding doors to be installed on the cabinet, mounting with plinths is required

01

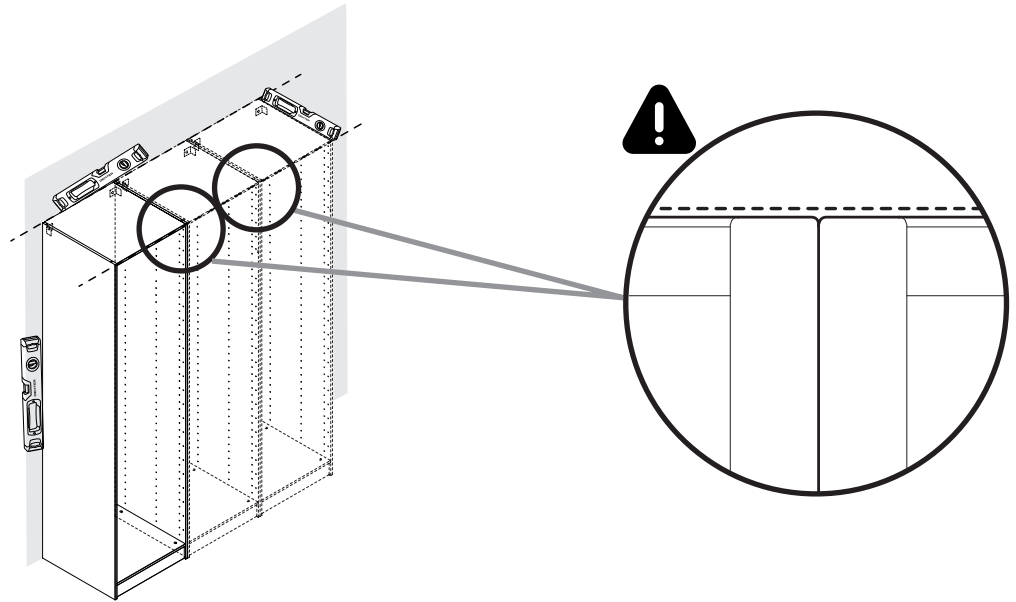

02

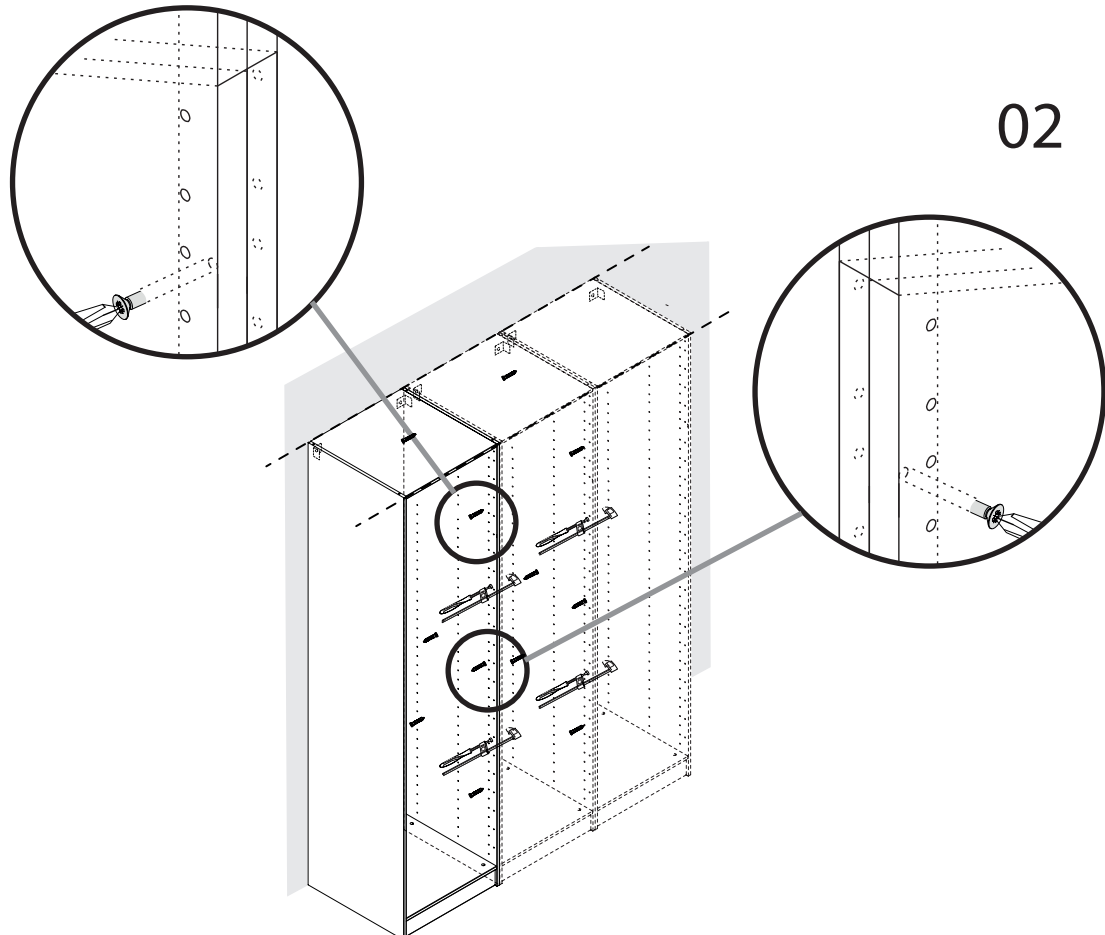

FR Installation du kit rail

ES Instalación del raíl
PT Instalação da calha
IT Installazione del binario
EL τοποθέτηση της ράγας
PL Montaż szyny
RO Instalarea șinei
EN Installing the rail

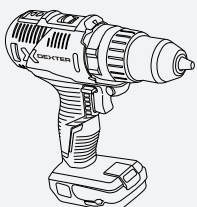
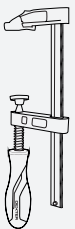
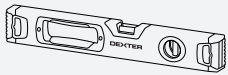
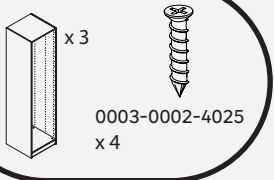



0003-0011-3525
x 8

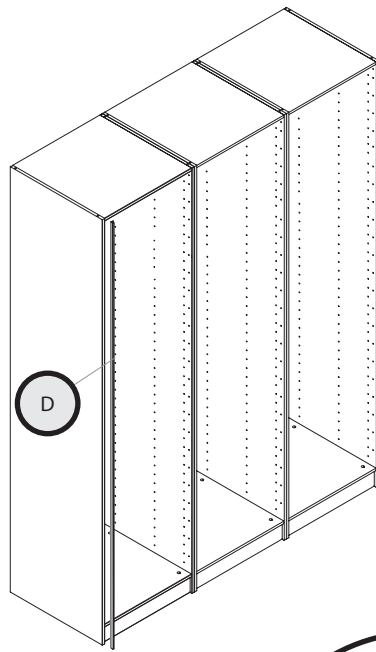
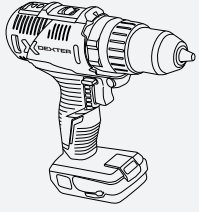

03

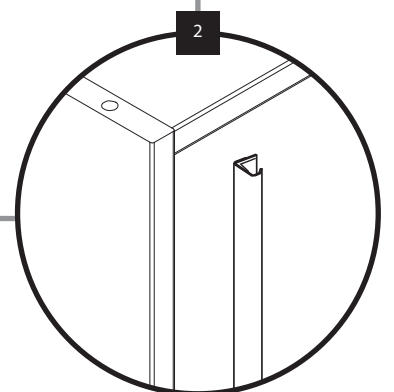
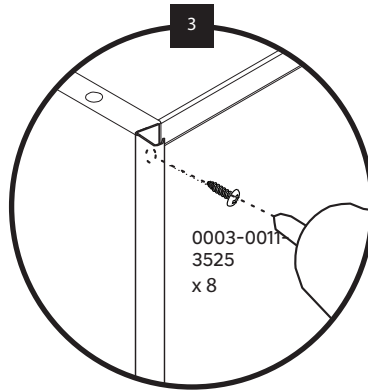
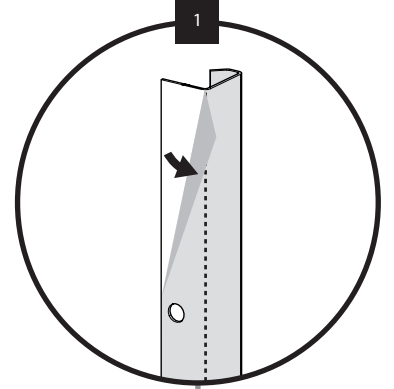

0003-0011-3525
x 8

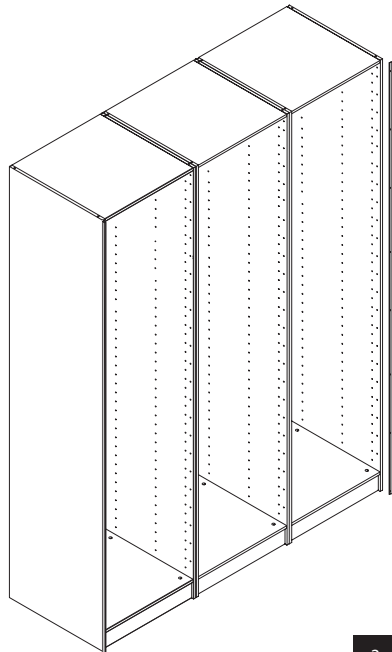
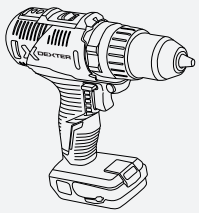

04

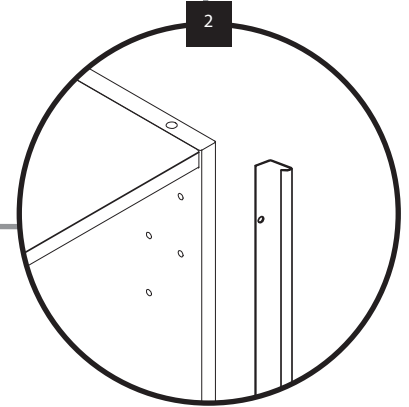
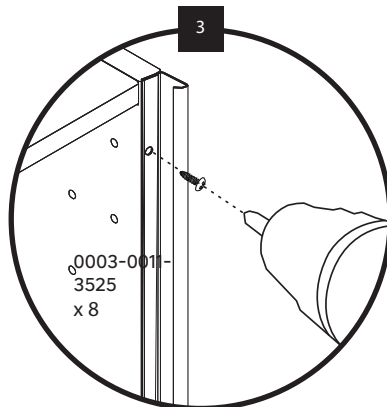
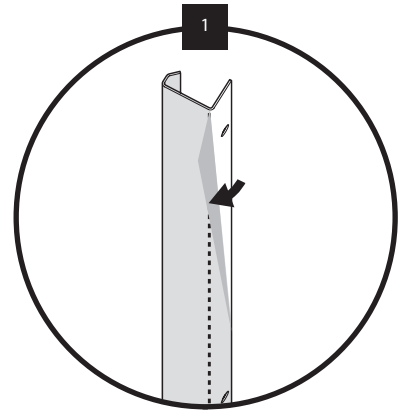



x 1



x 1



0003-0002-3516
x 4

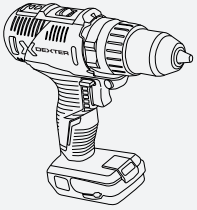

05

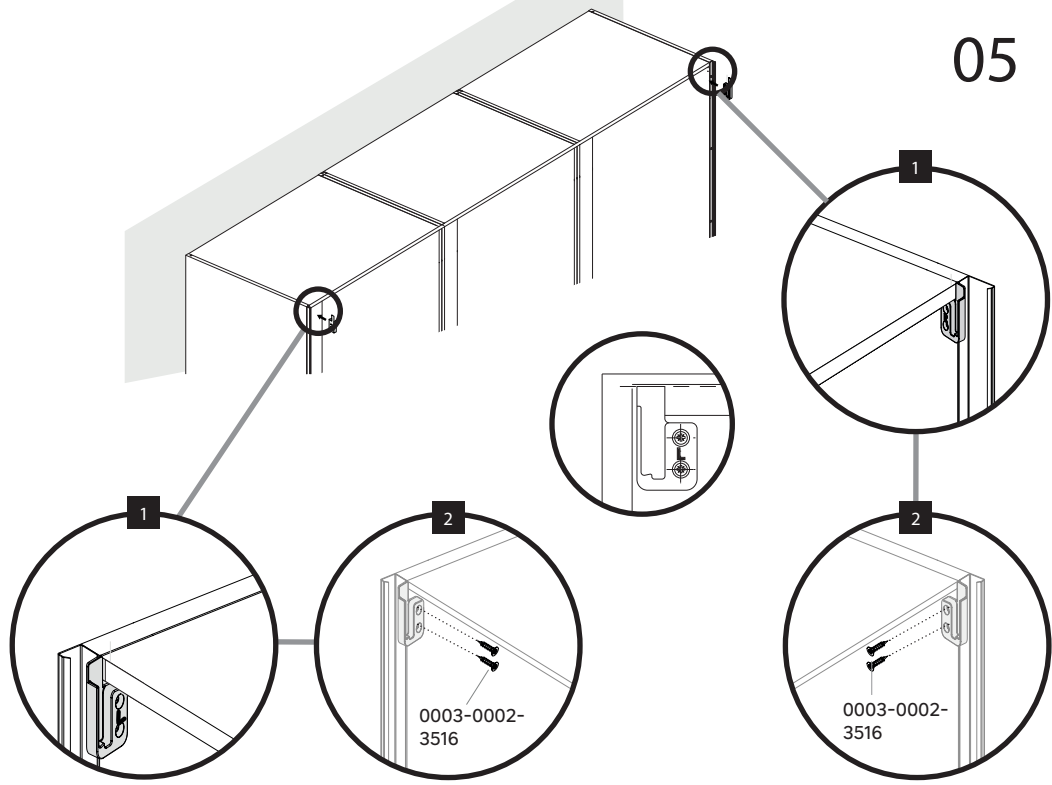

06

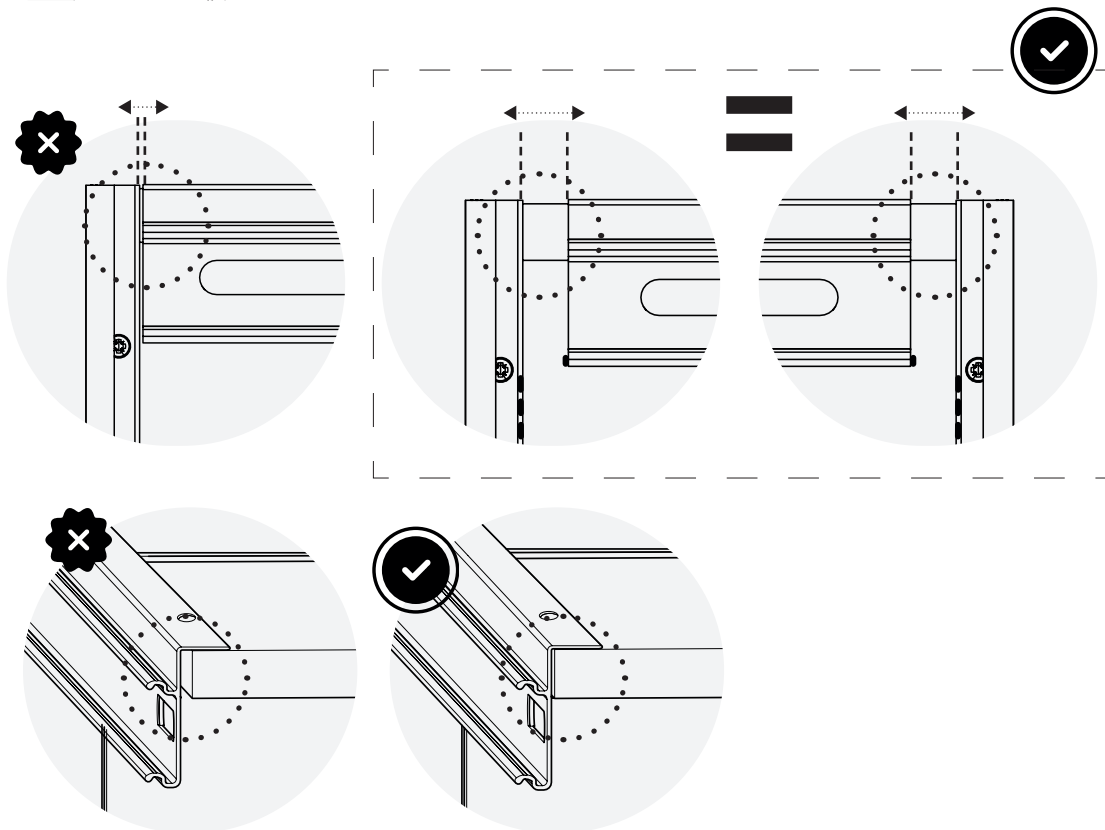
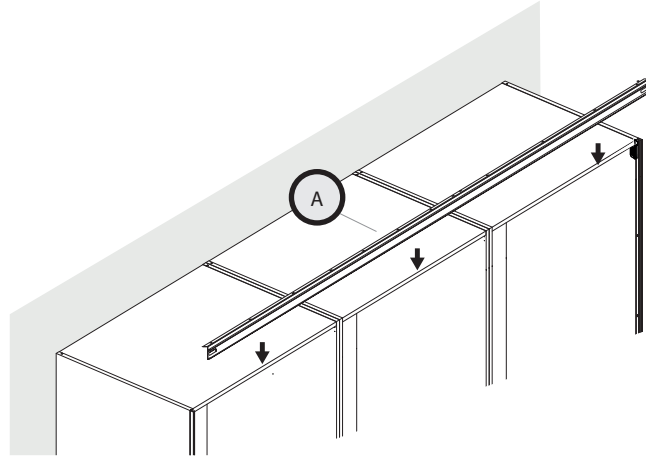
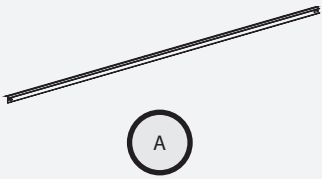

07

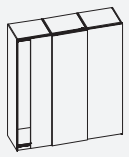

0003-0002-3516
x 8

↔ 180

PZ2

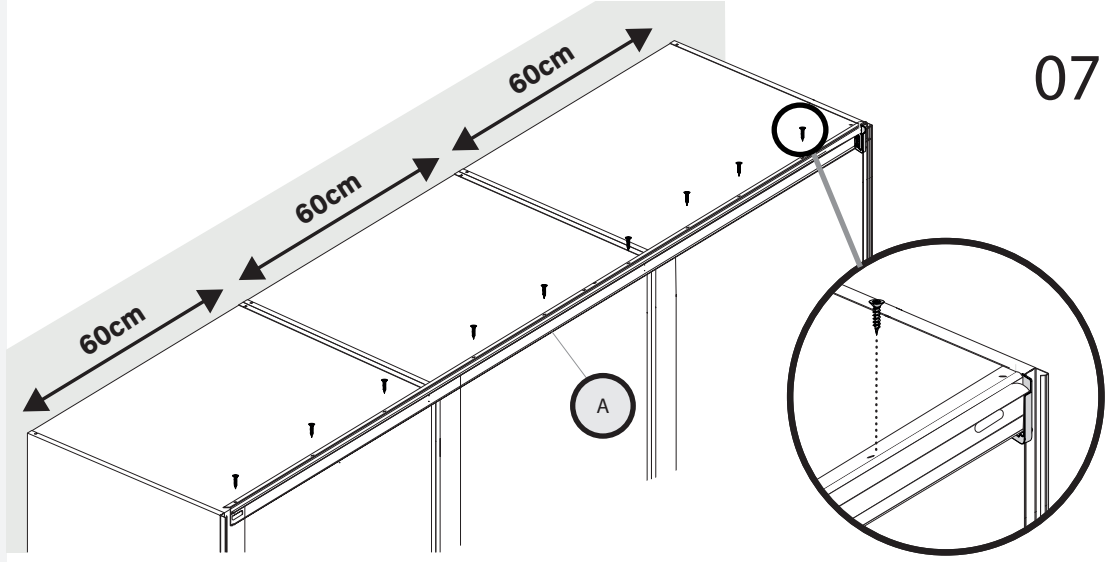

0003-0002-3516
x 11

↔ 240

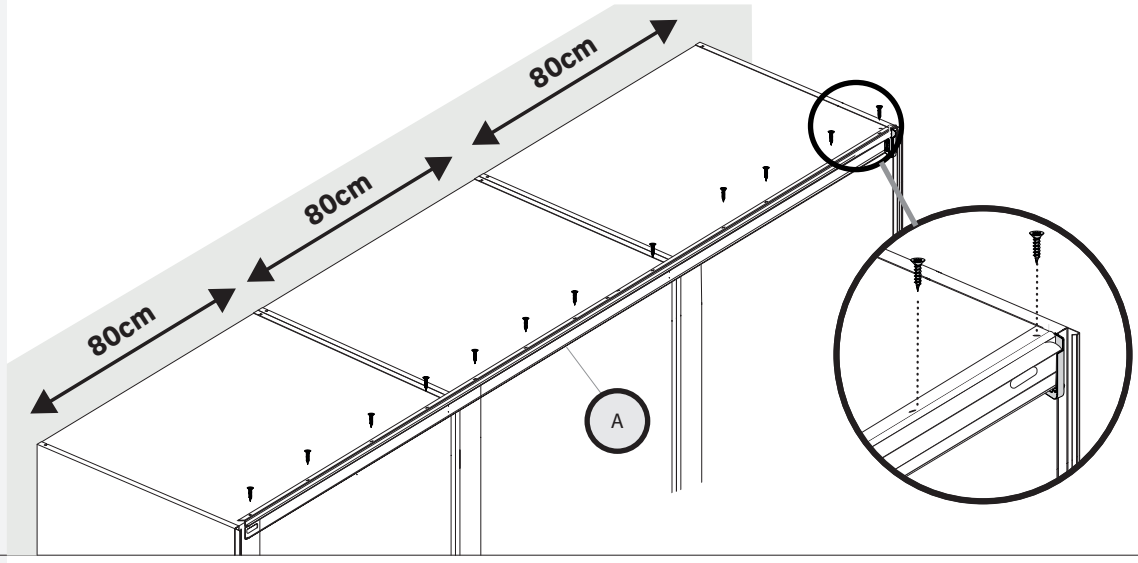

08



x 2



3,5x15
x 2

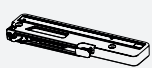

x 2

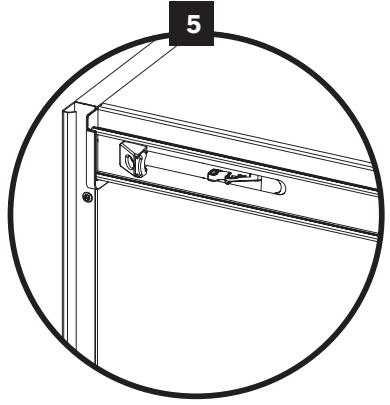
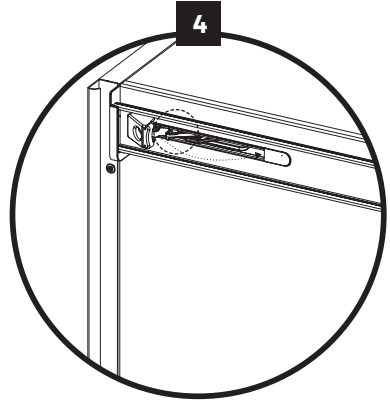
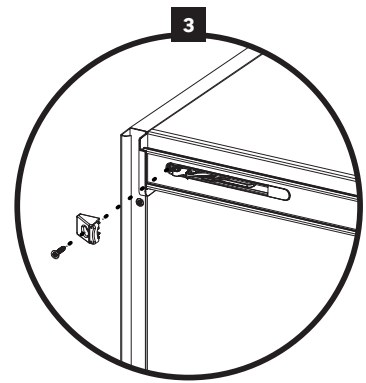
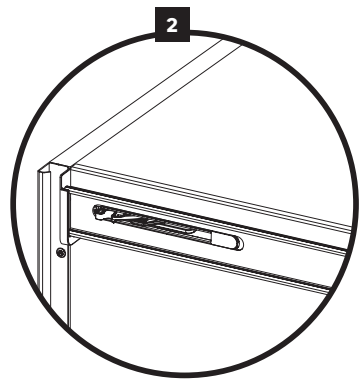
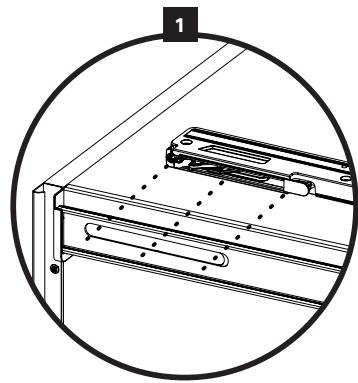



x 1



0003-0002-3516

x 2

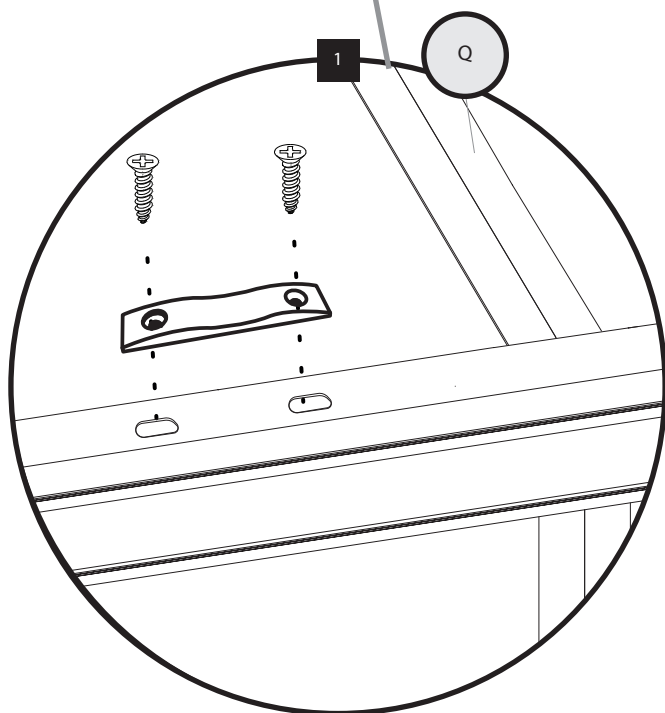
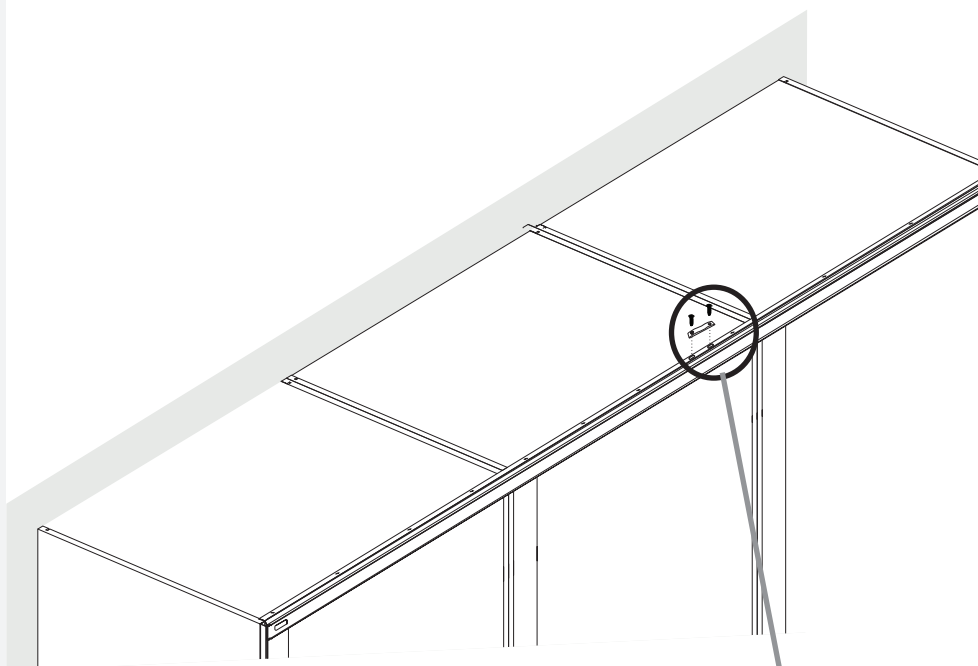



0003-0009-4015
x 12

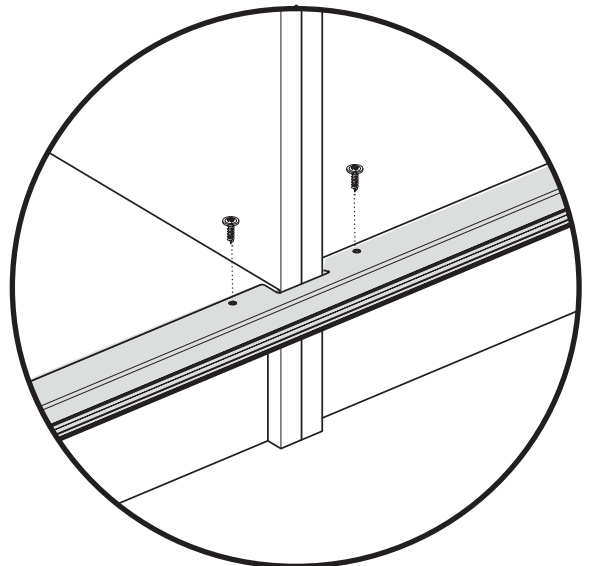
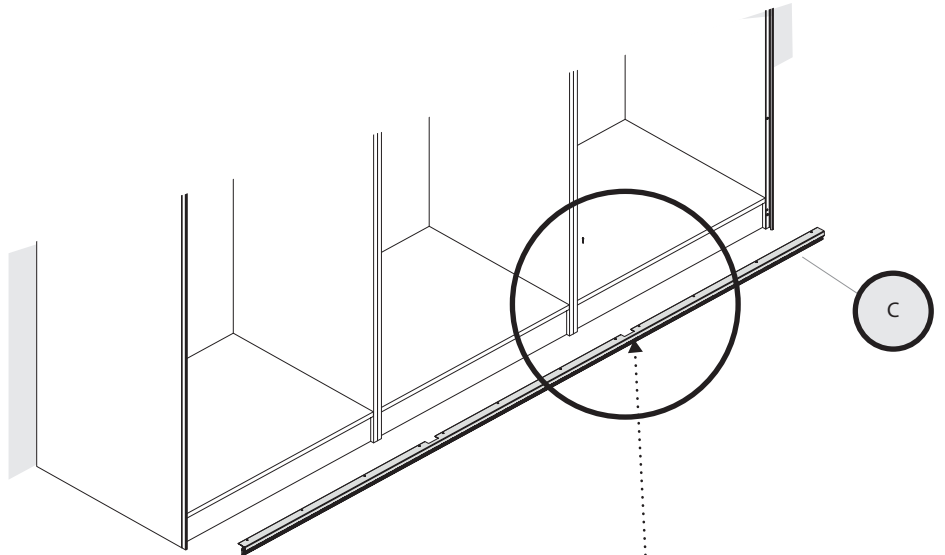
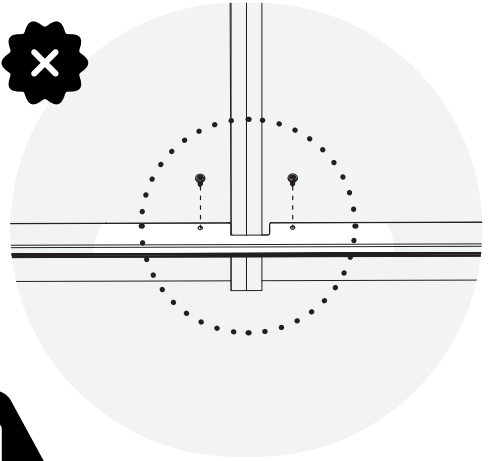
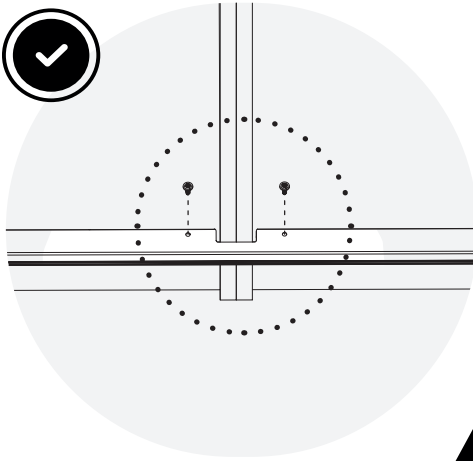
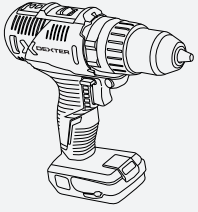



0003-0009-4015
x 9

↔ 180

PZ2

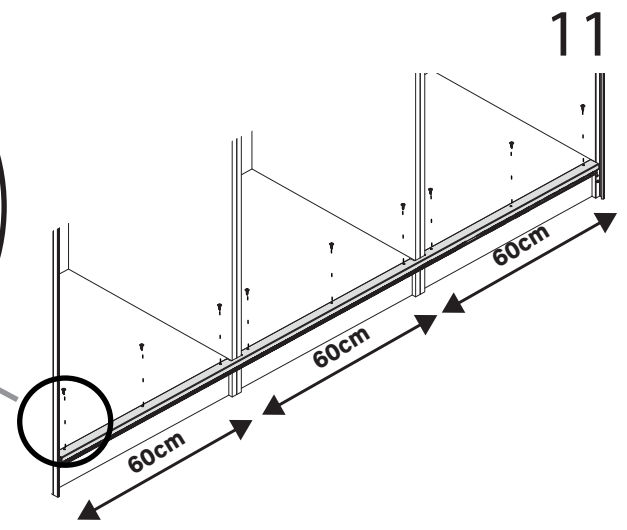
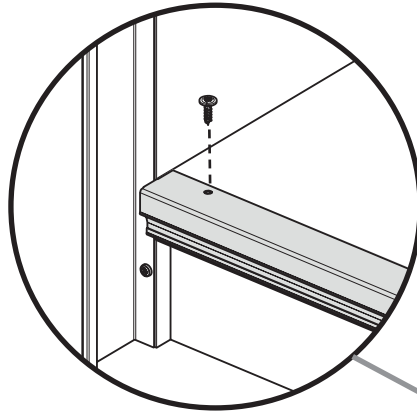

0003-0009-4015
x 12

↔ 240

PZ2

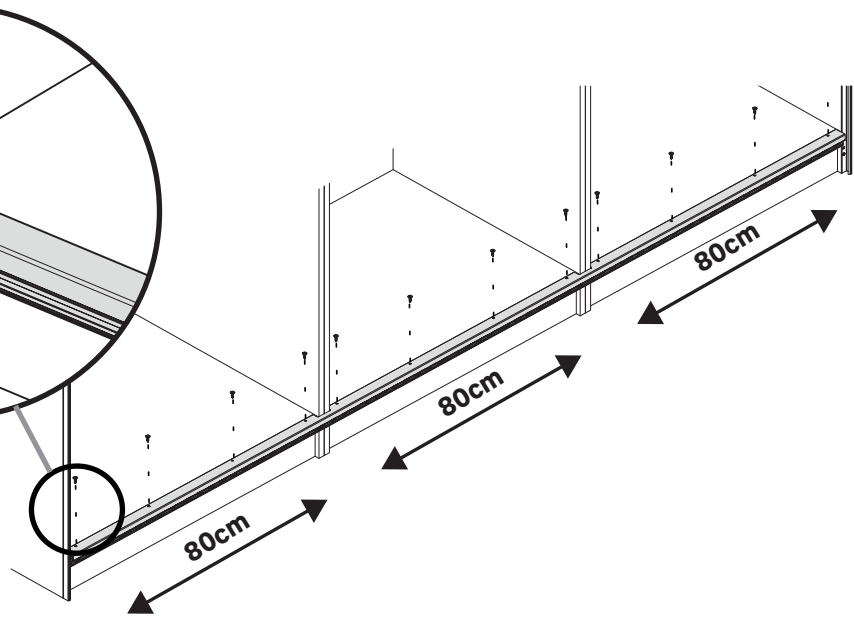
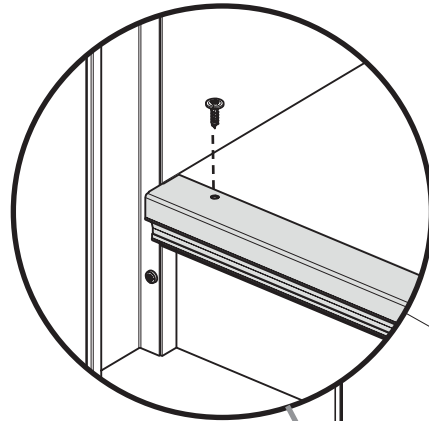

FR Installation des portes coulissantes

ES Instalación de puertas correderas

PT Instalação de portas de correr

IT Installazione di porte scorrevoli

EL Εγκατάσταση συρόμενων θυρών

PL Montaż drzwi przesuwanych

RO Instalarea ușilor glisante

EN Installing sliding doors

- FR Optionnel, poignets seulement pour les portes coulissantes 4 panneaux
- ES Opcional, tiradores sólo para puertas correderas de 4 paneles
- PT Opcional, apenas para portas de correr de 4 painéis
- IT Opzionale, maniglie solo per porte scorrevoli a 4 pannelli
- EL Προαιρετικά, χειρολαβές μόνο για συρόμενες πόρτες 4 πάνελ
- PL Opcjonalnie, uchwyty tylko dla 4-panelowych drzwi przesuwanych
- RO Opțional, mânere numai pentru uși glisante cu 4 panouri
- EN Optional, handles only for 4-panel sliding doors

12

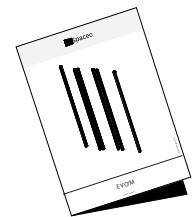
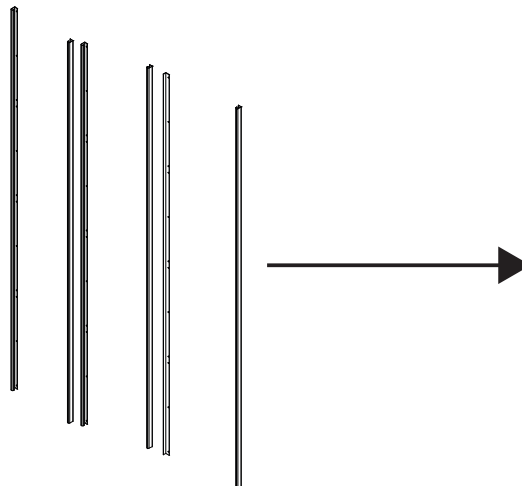



F

x 1



G

x 1



J

x 2



L

x 1

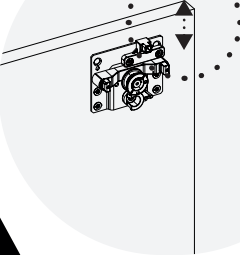
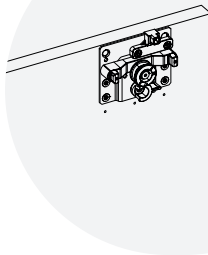
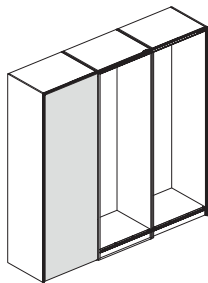

0003-0002-3516
x 2



0003-0002-4012
x 12

PZ2

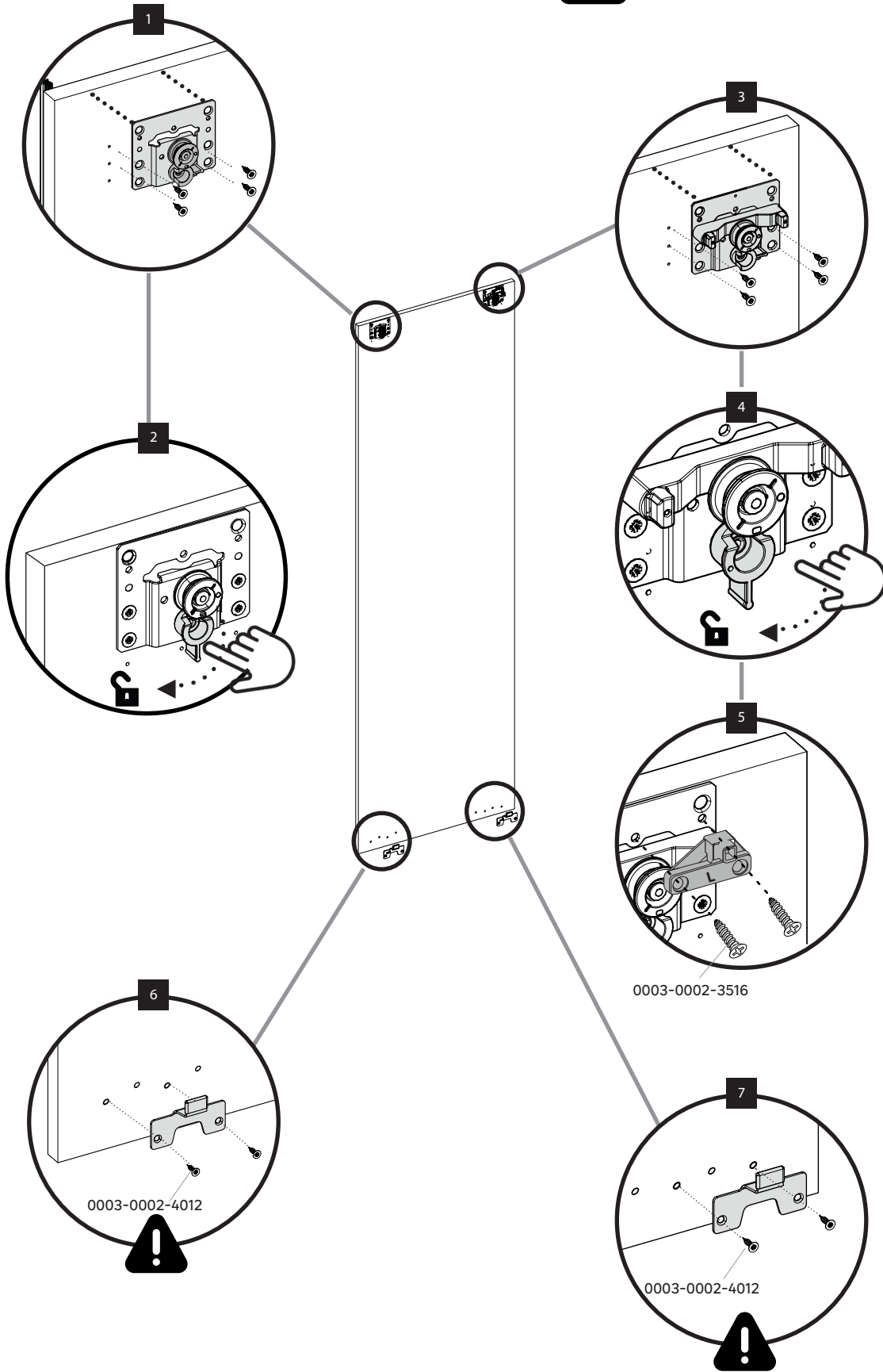

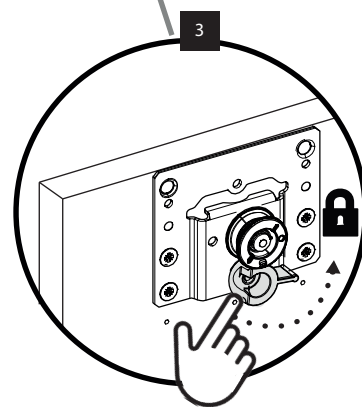
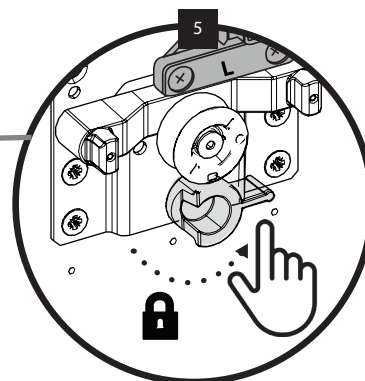
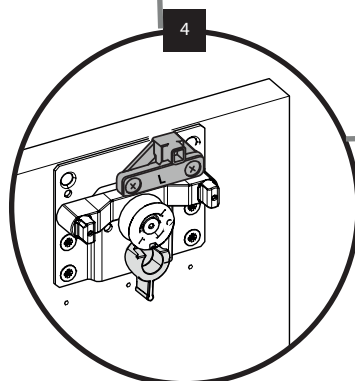
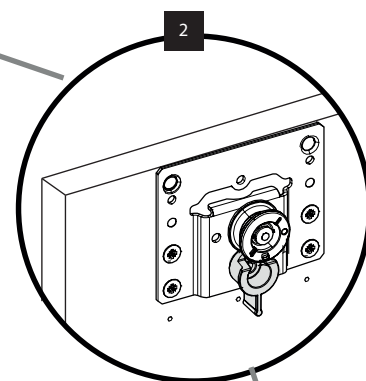
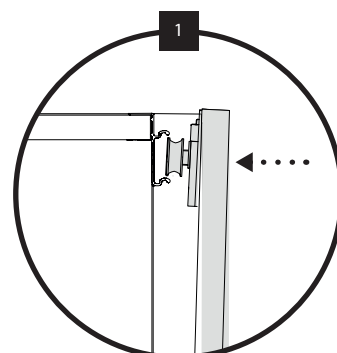
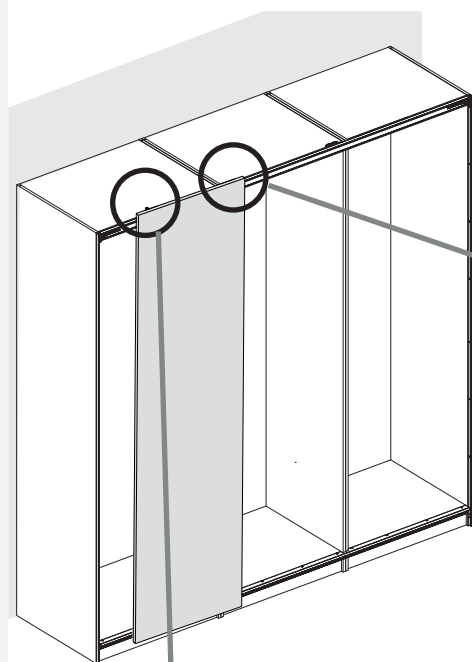
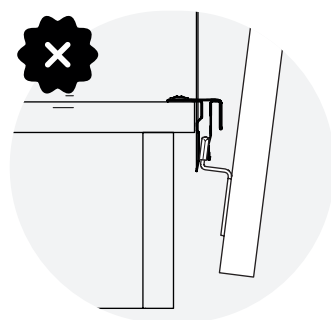
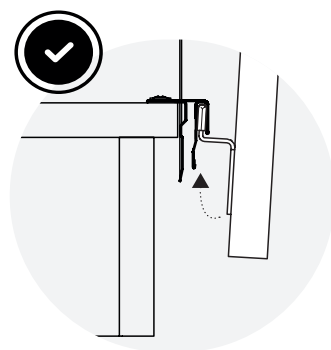
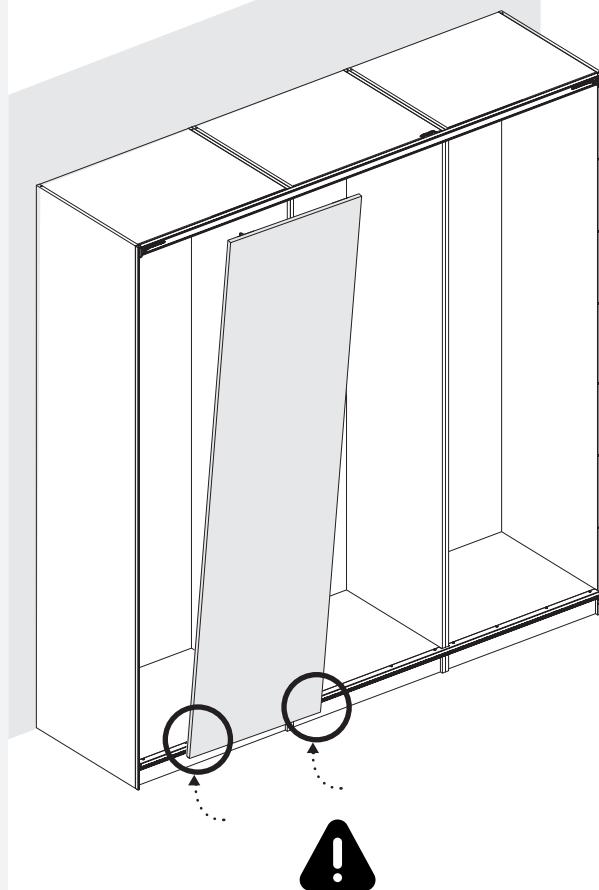

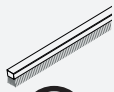

U

x2

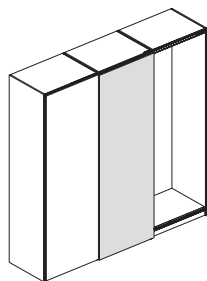

16

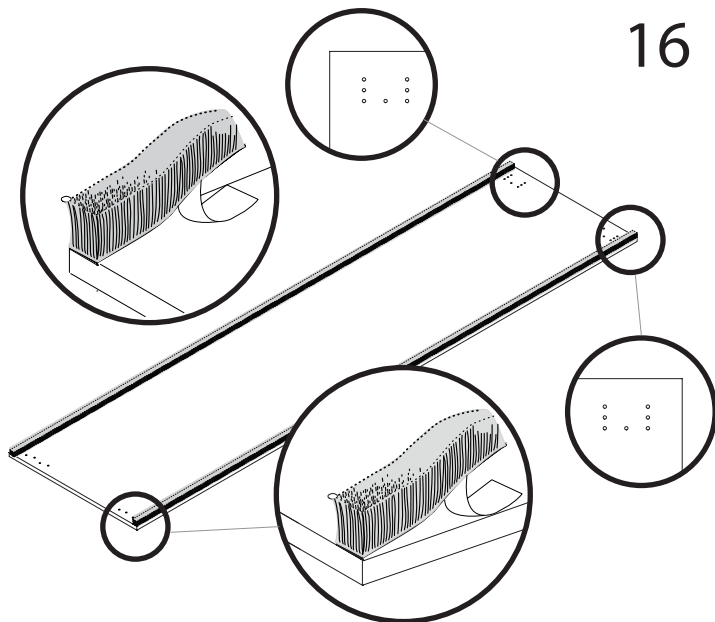

H

x1



I

x1



K

x2



S

x1



0003-0002-4012
x 22



0003-0004-4060
x 2

PZ2



17

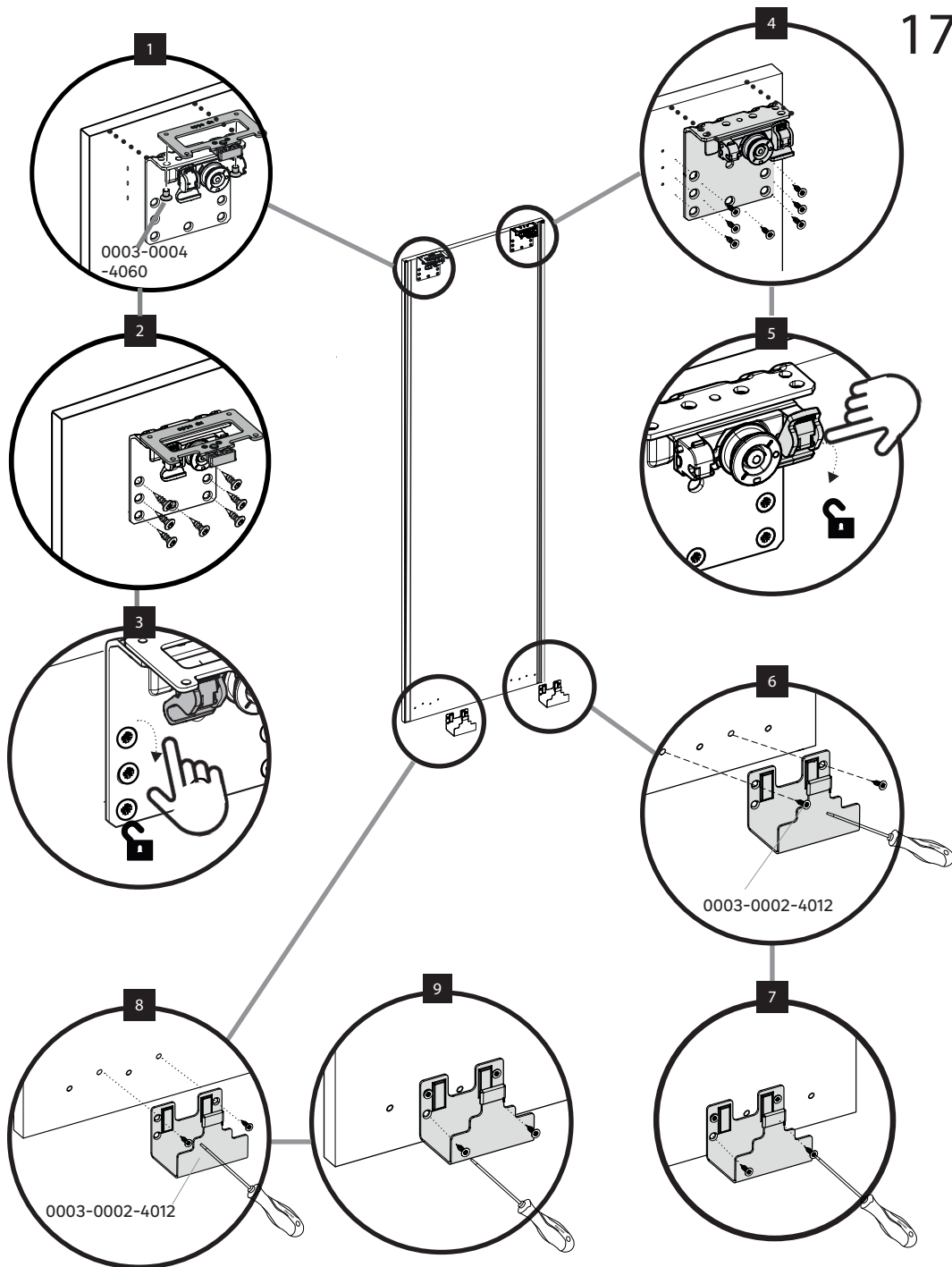

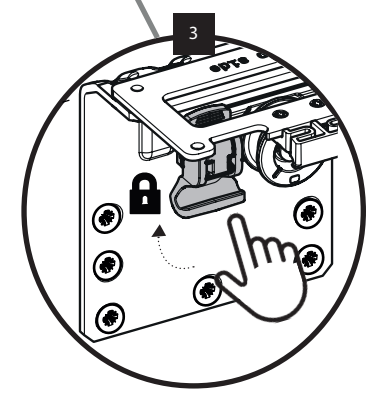
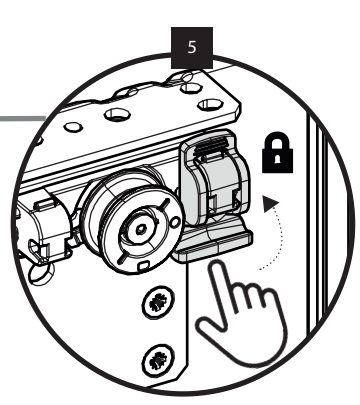
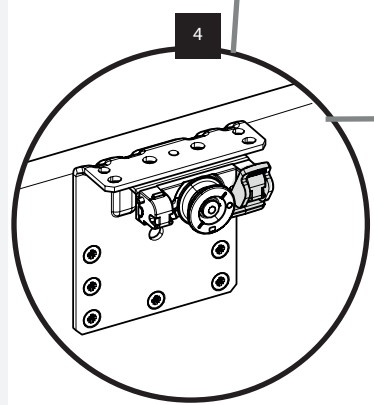
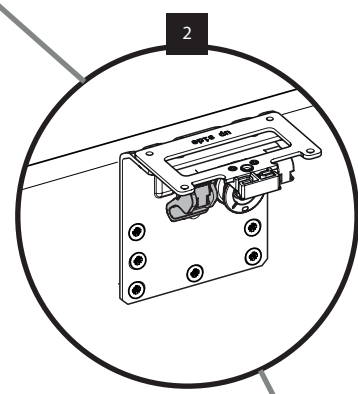
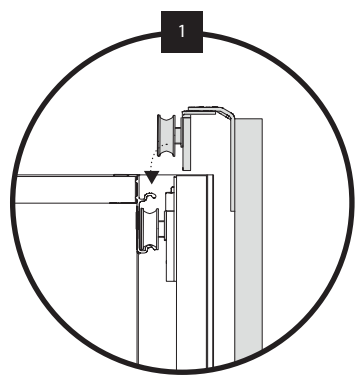
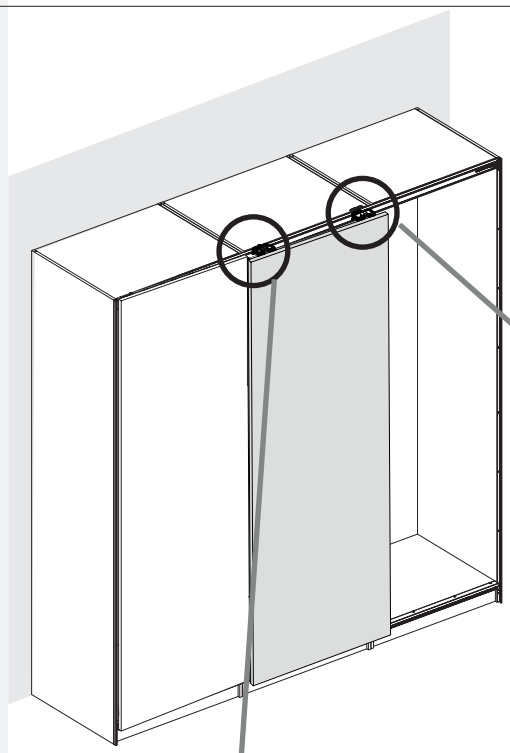
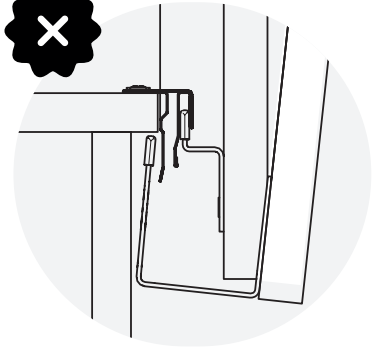
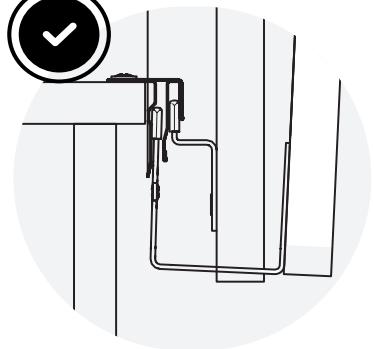
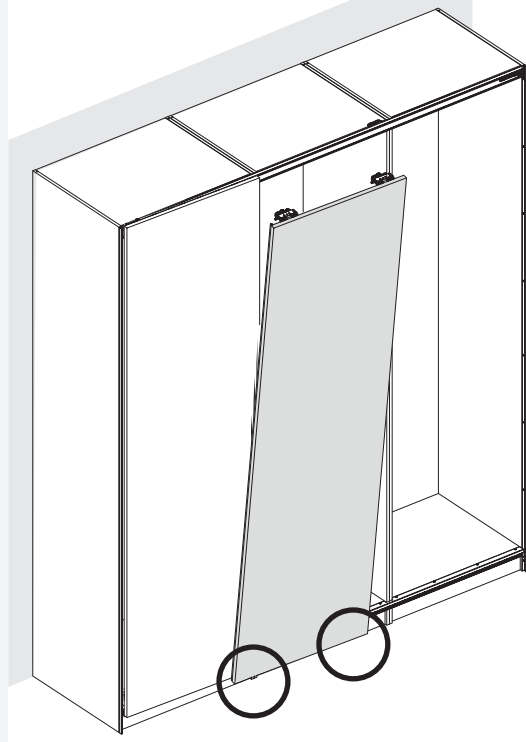



F
x1



G
x1



J
x2



R
x1



0003-0002-3516
x2



0003-0002-4012
x12

PZ2

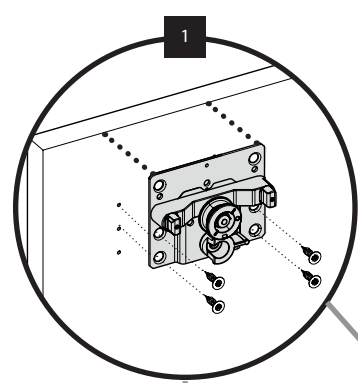
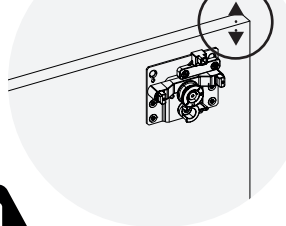
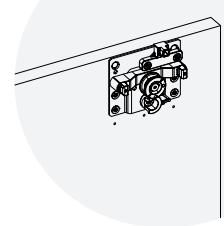
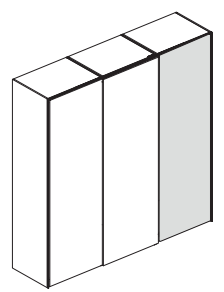

1

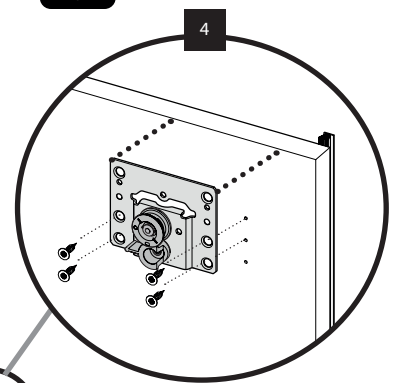

4

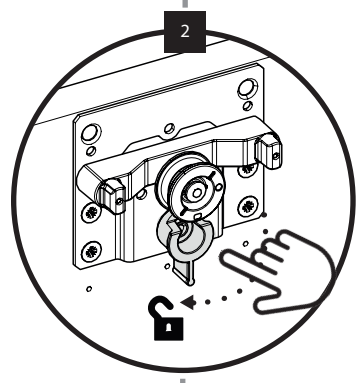

2

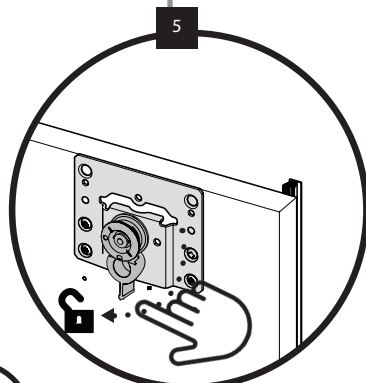

5

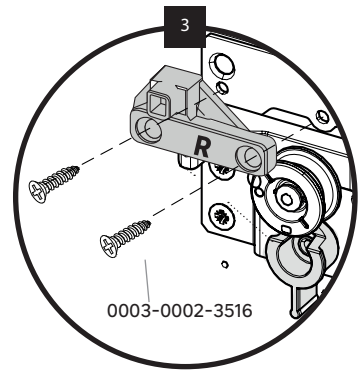

3

0003-0002-3516

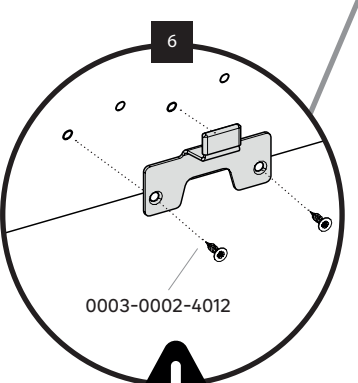

6

0003-0002-4012

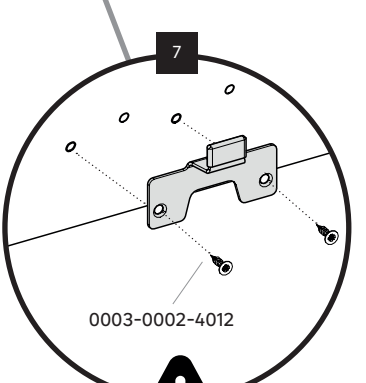

7

0003-0002-4012



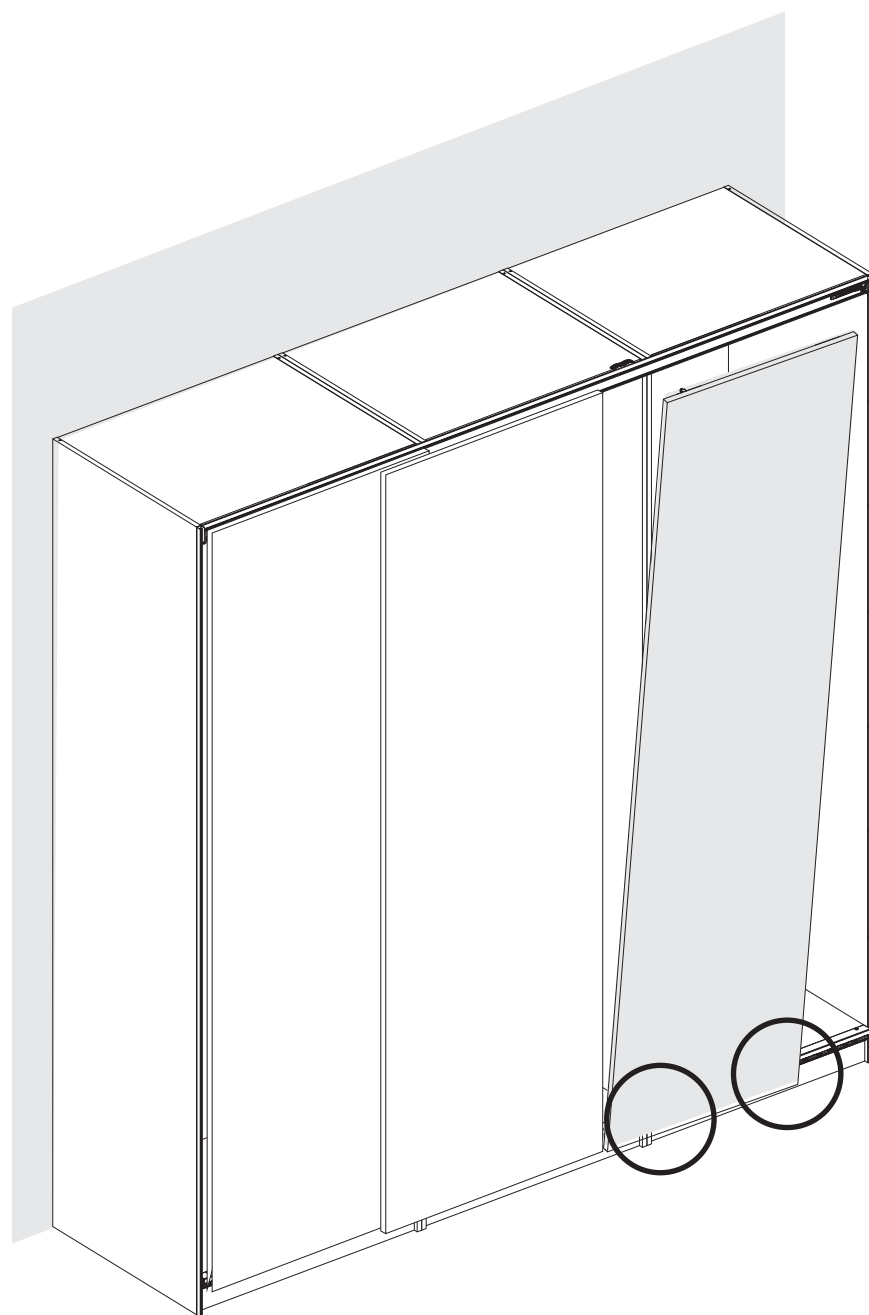
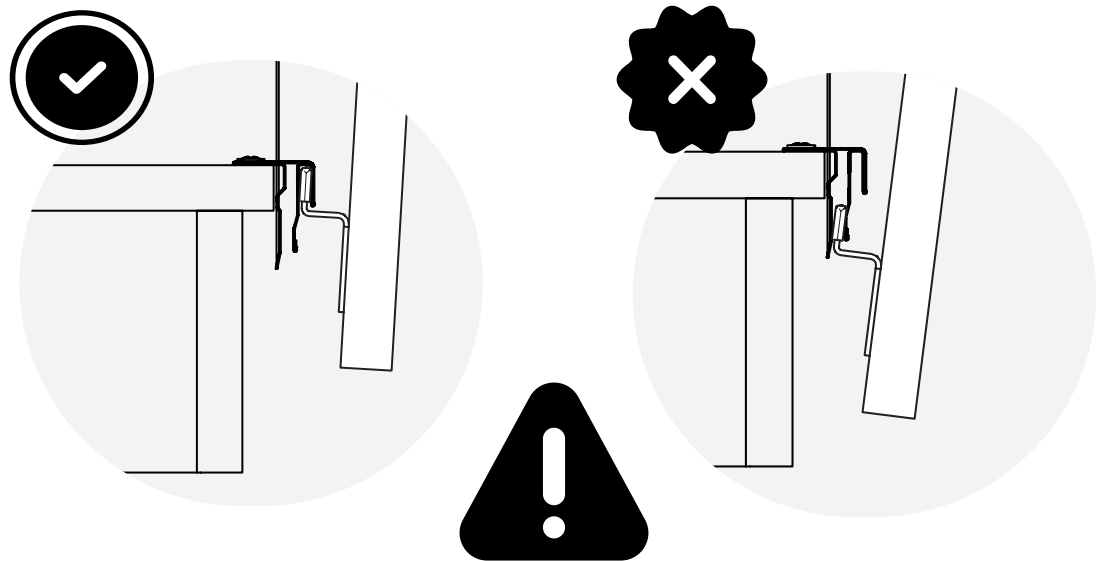

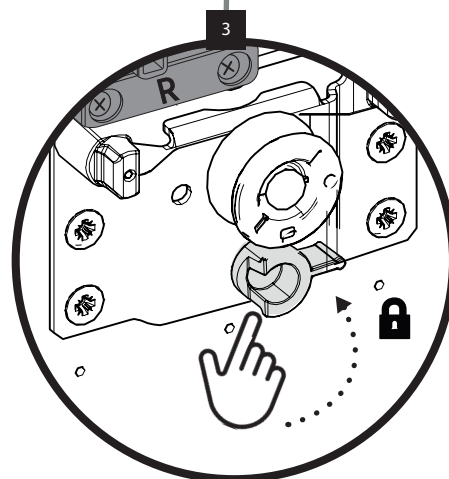
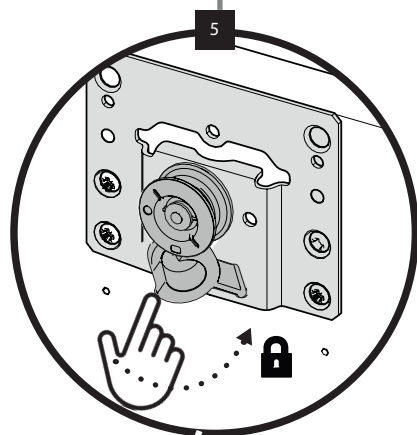
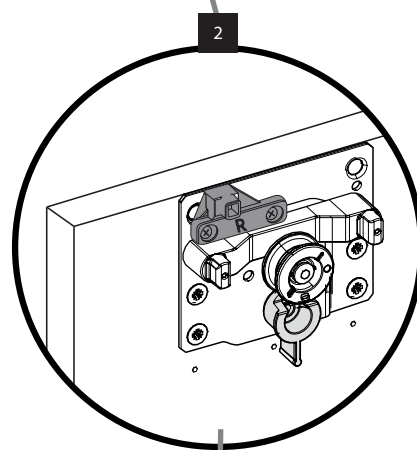
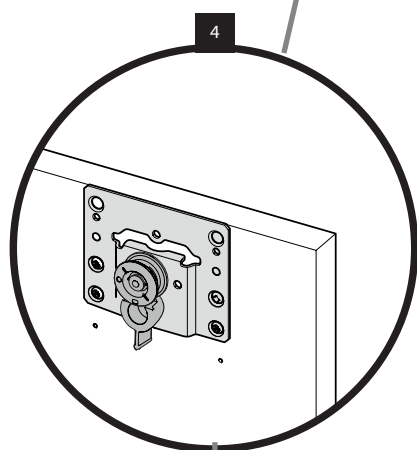
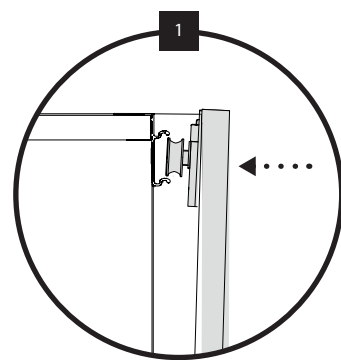
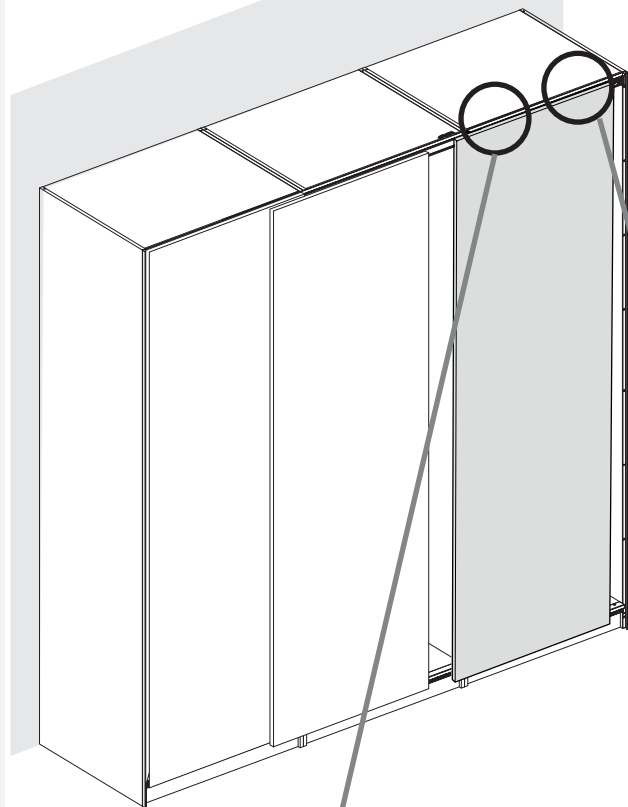

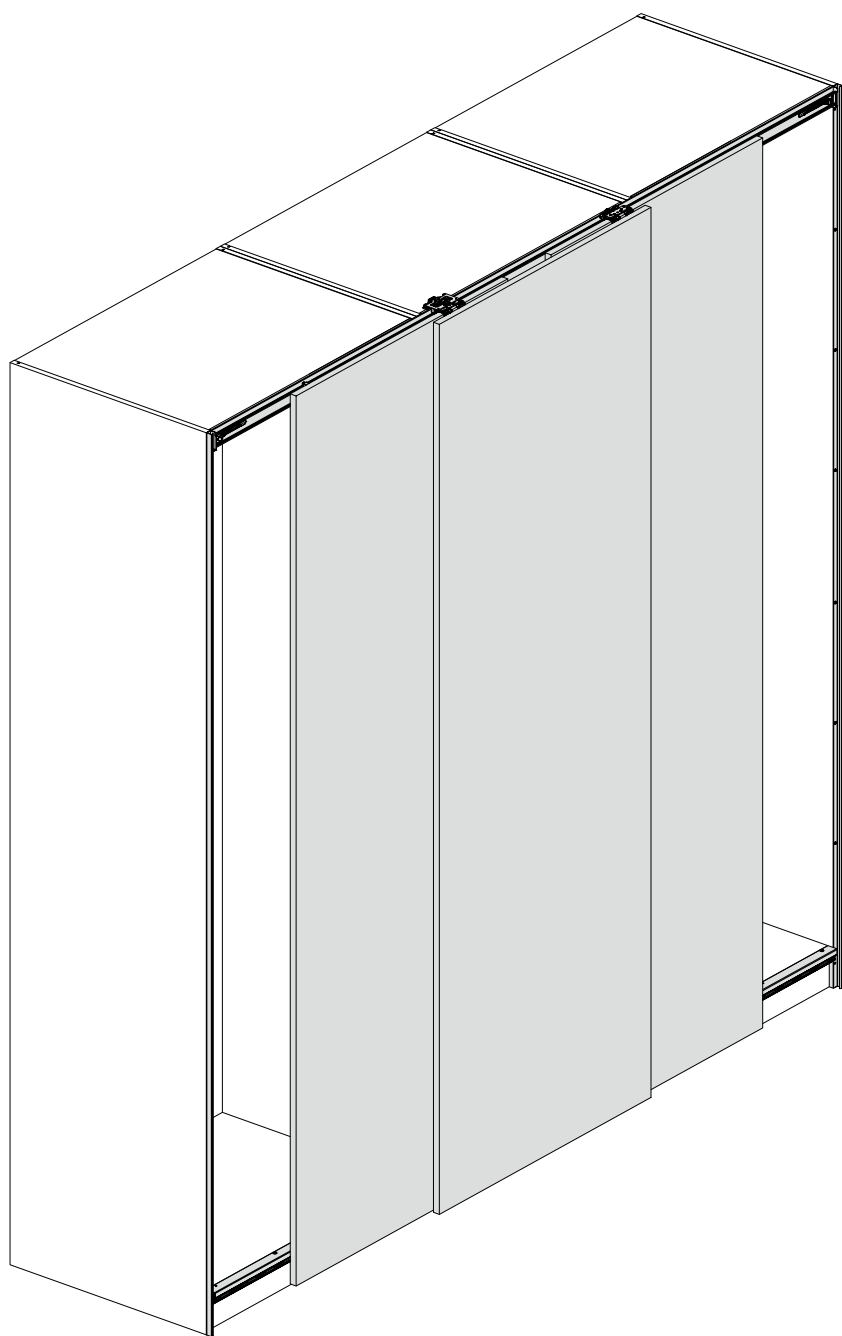



FR Ce meuble se recycle, s'il n'est plus utilisable, déposez-le en déchèterie. Notice à trier. Pour en savoir plus : www.quefairedemesdechets.fr



FR Etiquette de traçabilité présente sur le produit. Référence à communiquer en cas de demande.

ES Este mueble se puede reciclar, si ya no te sirve, llévalo al centro de reciclaje.

PT Este móvel pode ser reciclado, se não for mais utilizável, leve-o ao centro de reciclagem.

IT Questo mobile può essere riciclato, se non è più utilizzabile portalo al centro di riciclaggio.

EL Αυτό το έπιπλο μπορεί να ανακυκλωθεί, αν δεν είναι πλέον χρησιμοποιήσιμο, μεταφέρετέ το στο έντρο ανακύκλωσης.

PL Ten mebel można poddać recyklingowi, jeśli nie nadaje się już do użytku, zanieś go do centrum recyklingu.

RO Această piesă de mobilier poate fi reciclată, dacă nu mai este utilizabilă, duceți-o la centrul de reciclare.

EN This piece of furniture can be recycled, if it is no longer usable, take it to the recycling center.

ES Etiqueta de trazabilidad presente en el producto. Referencia a comunicar en caso de solicitud.

PT Etiqueta de rastreabilidade presente no produto. Referência a ser comunicada em caso de solicitação.

IT Etichetta di tracciabilità presente sul prodotto. Riferimento da comunicare in caso di richiesta.

EL Ετικέτα ιχνηλασιμότητας που υπάρχει στο προϊόν. Παραπομπή που πρέπει να κοινοποιείται σε περίπτωση αιτήματος.

PL Etykieta identyfikowalności obecna na produkcie. Odniesienie do przekazania w przypadku wniosku.

RO Eticheta de trasabilitate prezenta pe produs. Referinta de comunicat in caz de solicitare.

EN Traceability label present on the product. Reference to be communicated in case of request.

15
YEAR
Guarantee*

FR Garantie 15 ans

ES 15 años de garantía

PT 15 anos de garantia

IT 15 anni di garanzia

EL 15 χρόνια εγγύηση

PL 15 lat gwarancji

RO 15 ani garantie

EN 15 year warranty

Imported by Adeo South Africa (PTY) LTD T/A Leroy Merlin, Hosted in Leroy Merlin Fourways Store, 35 Roos Street, Witkoppen Ext 97, Sandton, 2191 Johannesburg, Gauteng, South Africa. Tel: +27 10 493 8000 Email: contact@leroymerlin.co.za

Adeo Services

135, rue Sadi Carnot
CS 00001
59790 Ronchin - France

