

Inspire

Trinx

EAN : 3276007817836
Adeo key : 91468790

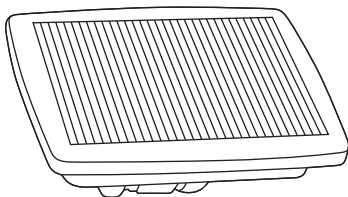
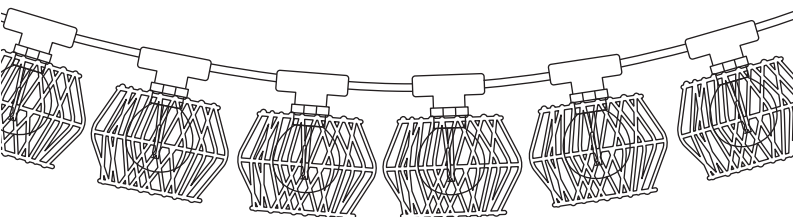

2/2



2024-09-V02

FR - Manuel d'Instructions
ES - Manual de Instrucciones
PT - Manual de Instruções
IT - Manuale di Istruzioni
EL - Εγχειρίδιο Οδηγιών
PL - Instrukcja Obsługi

UA - Інструкція з Експлуатації
RO - Manual de Instrucțiuni
BR - Manual de Instrução
NL - Handleiding
DE - Anleitung Handbuch
EN - Instructions Manual

*Année de garantie/años de garantía/Ano de garantía/Anno di garanzia/Έτος εγγύησης/Rok gwarancji/Гарантія років/Anul de garanție/Anos de garantia/Garantiejaar/Jahr der Garantie/Year of guarantee

**réparable/reparable/reparável/riparabile/διορθώσιμος/naprawiany/ремонтний/reparabil/reparaturfähig/reparável/herstelbaar/reparierbar/reparable



FR: assemblage / **ES:** ensamblaje / **PT:** montagem / **IT:** assemblaggio /
EL: συναρμολόγηση / **PL:** montaż / **UA:** збірка / **RO:** asamblare /
BR: montagem / **NL:** samenstelling / **DE:** Montage / **EN:** assembly



FR: Utilisation / **ES:** Uso / **PT:** Utilização / **IT:** Utilizzo
EL: Χρήση / **PL:** Użycie / **UA:** Використання / **RO:** Utilizare /
BR: Utilização / **NL:** Gebruik / **DE:** Verwendung / **EN:** Use

FR: CARACTÉRISTIQUES TECHNIQUES / **ES:** CARACTERÍSTICAS TÉCNICAS /
PT: CARACTERÍSTICAS TÉCNICAS / **IT:** CARATTERISTICHE TECNICHE / **EL:** ΤΕΧΝΙΚΑ
ΧΑΡΑΚΤΗΡΙΣΤΙΚΑ / **PL:** CECHY TECHNICZNE / **UA:** ТЕХНІЧНІ ХАРАКТЕРИСТИКИ /
RO: CARACTERISTICI TEHNICE / **BR:** CARACTERÍSTICAS TÉCNICAS / **NL:** TECHNISCHE KENMERKEN
/ **DE:** TECHNISCHE MERKMALE / **EN:** TECHNICAL SPECIFICATIONS

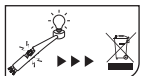

- FR** Ce produit contient une source lumineuse G40-10 de classe d'efficacité énergétique D.
ES Este producto contiene una bombilla G40-10 de clase de eficiencia D.
PT Este produto contém uma fonte de luz G40-10 de eficiência energética de classe D.
IT Questo prodotto contiene una sorgente luminosa G40-10 di classe di efficienza energetica D.
EL Αυτό το προϊόν περιέχει πηγή φωτός G40-10 κατηγορίας ενεργειακής απόδοσης D.
PL Niniejszy produkt zawiera źródło światła G40-10 klasy efektywności energetycznej D.
UA Данное изделие содержит источник G40-10 света класса энергоэффективности D.
RO Acest produs conține o sursă de lumină G40-10 din clasa de eficiență energetică D.
DE Dieses Produkt enthält ein Licht G40-10 der Energieeffizienzklasse D.
EN This product includes a light G40-10 of the energy efficiency class D.



A

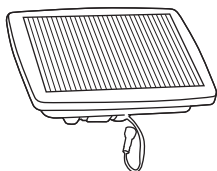

B

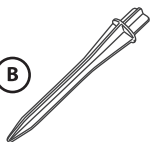

C



D x3



E x3



F x2



∅ 6mm

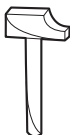

•



+ PZ

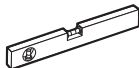

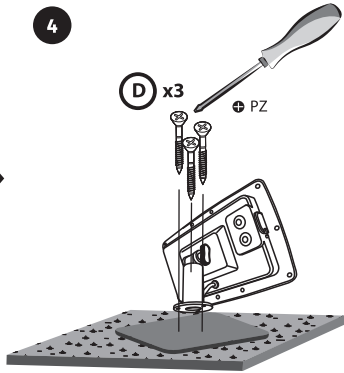
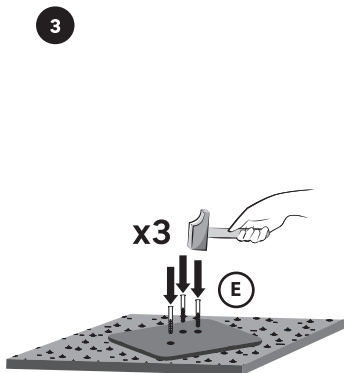
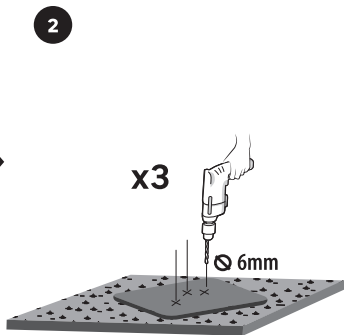
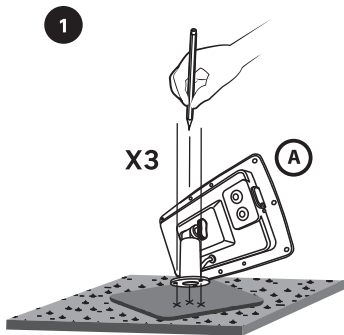
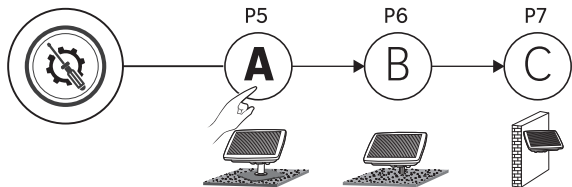

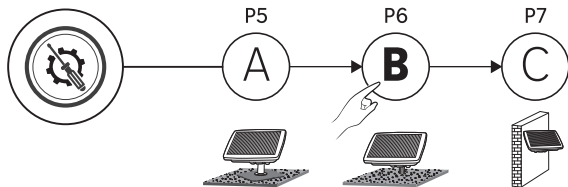

1

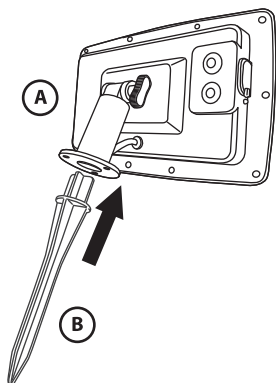

2

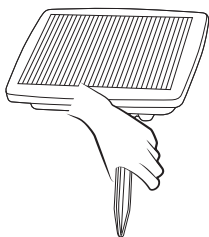

3

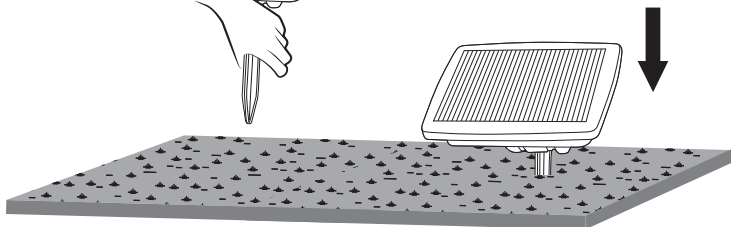

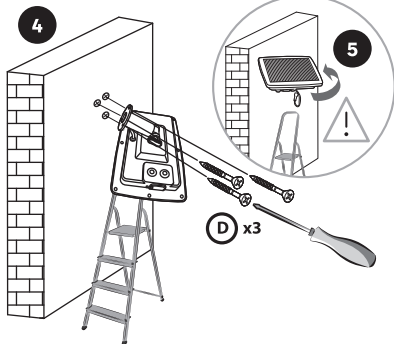
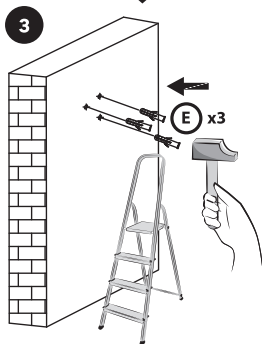
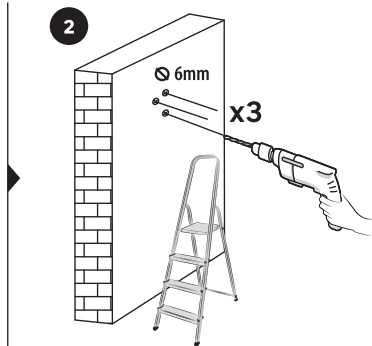
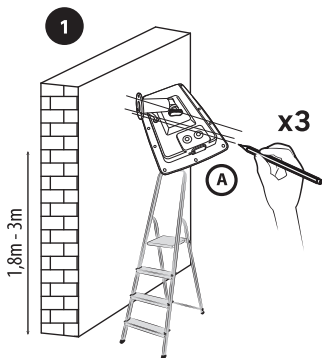
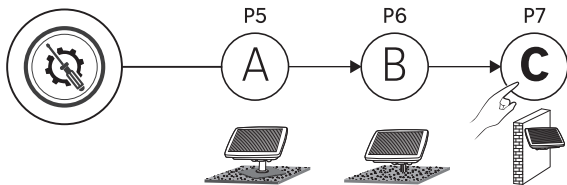

FR - Utiliser des vis et des chevilles adaptées à votre support. / ES - Utilice tacos y tornillos adecuados al soporte. / PT - Utilize buchas e parafusos adequado ao seu suporte.
 / IT - Utilizzare viti e tasselli adatti per il retro. / GR - Χρησιμοποιήστε βίδες και βύσματα που ταιριάζουν στην επιφάνεια στηρίξης. / PL - Należy użyć śrub i kółków odpowiednich dla podłoża. / UA - Використовуйте гвинти та шканти, призначені для задньої поверхні. / RO - Utilizați șuruburi și dibluri adecvate pentru suportul dvs. /
 BR - Use parafusos e buchas adequados para seu suporte. / NL - Gebruik schroeven en pluggen die geschikt zijn voor uw ondergrond. / DE - Verwenden Sie für Ihre Unterlage geeignete Schrauben und Dübel. / EN - Use screws and dowels suited to your backing.



1

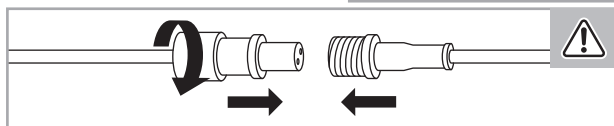
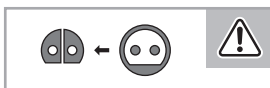
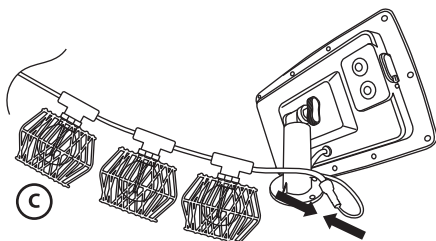

2

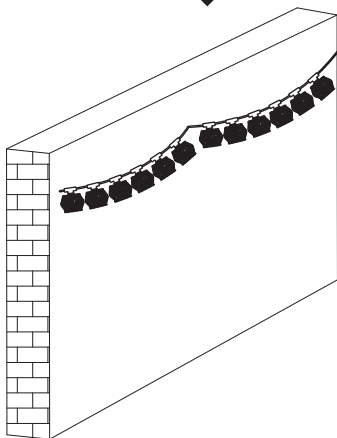



1

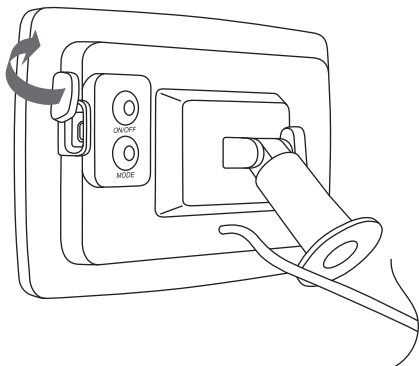

2

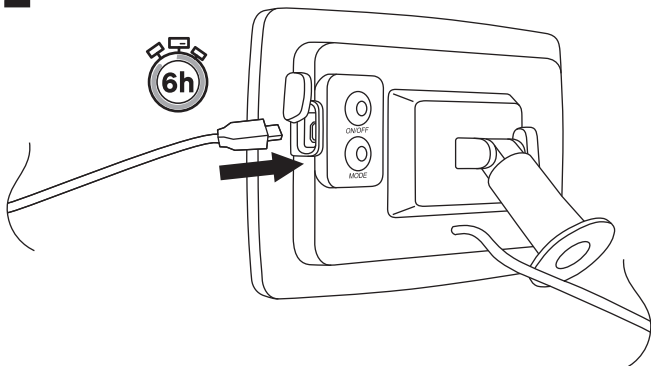



EN: Hide the solar panel with the pack to test the setting of your product*

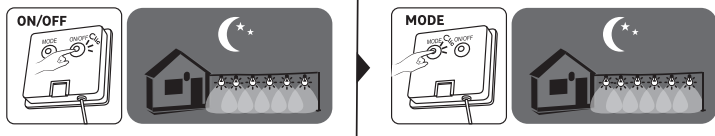
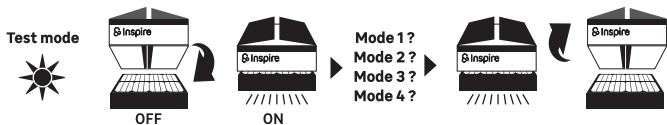

Mode 1: Fixe 50% / Fijo 50% / Fixo 50% / Fissato 50% / Σταθερός 50% / Staty 50% / Фіксований 50% / Fix 50% / Fixo 50% / Vast 50% / Fest 50% / Fixed 50%

Mode 2: Fondù 50% / Respiración 50% / Desvanecer-se 50% / Sfumatura 50% / Σβήσιμο 50% / Zanik 50% / Вицвітання 50% / Se estompează 50% / Desbotamento 50% / Vervagen 50% / Verblassen 50% / Fade 50%

Mode 3: Flash 50% / Flash 50% / Flash 50% / Flash 50% / Φλας 50% / Blysk 50% / Спалах 50% / Blitz 50% / Flash 50% / Flitser 50% / Blitz 50% / Flash 50%

Mode 4: Fixe 100% / Fijo 100% / Fixo 100% / Fissato 100% / Σταθερός 100% / Staty 100% / Фіксований 100% / Fix 100% / Fixo 100% / Vast 100% / Fest 100% / Fixed 100%

*FR: Cachez le panneau solaire avec le pack pour tester le réglage de votre produit *ES: Oculta el panel solar con el paquete para probar la configuración de tu producto *PT: Esconda o painel solar com o pacote para testar a configuração do seu produto *IT: Nascondi il pannello solare con il pacchetto per testare l'impostazione del tuo prodotto *EL: Κρύψτε τον ηλιακό πίνακα με το πακέτο για να δοκιμάσετε τη ρύθμιση του προϊόντος σας *PL: Ukryj panel słoneczny za pomocą pakietu, aby przetestować ustawienie swojego produktu *UA: Приховайте сонячну панель з пакетом, щоб перевірити налаштування вашого продукту *RO: Ascundeți panoul solar cu pachetul pentru a testa setarea produsului dvs. *BR: Esconda o painel solar com o pacote para testar a configuração do seu produto *NL: Verberg het zonnepaneel met de verpakking om de instelling van uw product te testen *DE: Verstecken Sie das Solarpanel mit dem Pack, um die Einstellung Ihres Produkts zu testen

FR: Instructions pour la réparation.
ES: Instrucciones para la reparación.
PT: Instruções para o reparo.
IT: Istruzioni per la riparazione.
EL: Οδηγίες για την επισκευή.
PL: Instrukcje dotyczące naprawy.

UA: Інструкції для ремонту.
RO: Instrucțiuni pentru reparare.
BR: Instruções para o reparo.
NL: Instructies voor de reparatie.
DE: Anweisungen zur Reparatur.
EN: Instructions for repair.



FR: Si votre produit rencontre un problème de fonctionnement, rapprochez-vous de votre revendeur pour connaître les références des pièces détachées pour la réparation de votre produit.

ES: Si su producto tiene un problema de funcionamiento, acérquese a su distribuidor para conocer las referencias de las piezas de repuesto para la reparación de su producto.

PT: Se o seu produto apresentar um problema de funcionamento, aproxime-se do seu revendedor para conhecer as referências das peças de reposição para a reparação do seu produto.

IT: Se il tuo prodotto ha un problema di funzionamento, avvicinati al tuo rivenditore per conoscere i riferimenti dei pezzi di ricambio per la riparazione del tuo prodotto.

EL: Εάν το προϊόν σας αντιμετωπίζει πρόβλημα λειτουργίας, πλησιάστε τον πωλητή σας για να μάθετε τις αναφορές των ανταλλακτικών για την επισκευή του προϊόντος σας.

PL: Jeśli Twój produkt ma problem z działaniem, skontaktuj się ze swoim sprzedawcą, aby poznać numery części zamiennych do naprawy Twojego produktu.

UA: Якщо ваш продукт має проблеми з роботою, зверніться до свого продавця, щоб дізнатися референції запасних частин для ремонту вашого продукту.

RO: Dacă produsul dvs. are o problemă de funcționare, apropiați-vă de revânzătorul dvs. pentru a cunoaște referințele pieselor de schimb pentru repararea produsului dvs.

BR: Se o seu produto apresentar um problema de funcionamento, aproxime-se do seu revendedor para conhecer as referências das peças de reposição para a reparação do seu produto.

NL: Als uw product een probleem heeft met de werking, neem dan contact op met uw dealer om de referenties van de reserveonderdelen voor de reparatie van uw product te kennen.

DE: Wenn Ihr Produkt ein Betriebsproblem hat, wenden Sie sich an Ihren Händler, um die Referenzen der Ersatzteile für die Reparatur Ihres Produkts zu erfahren.

EN: If your product has an operating problem, get closer to your dealer to know the references of the spare parts for the repair of your product.

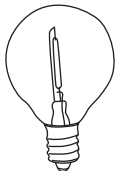

1 **1**

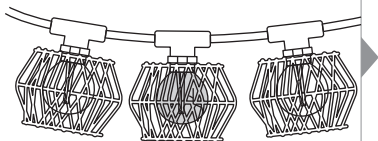

2

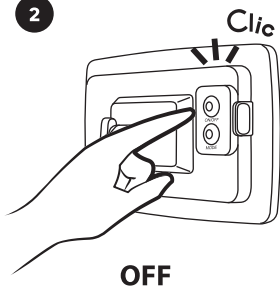

2 **1**

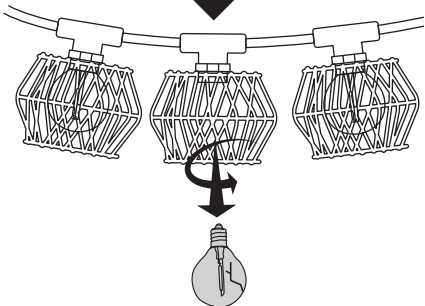

2

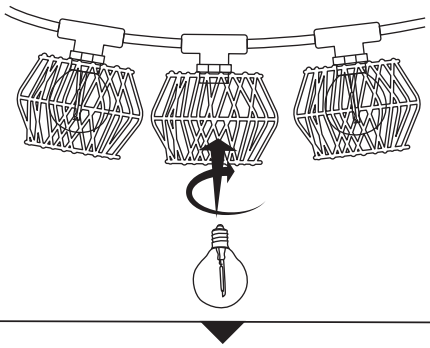

3 1

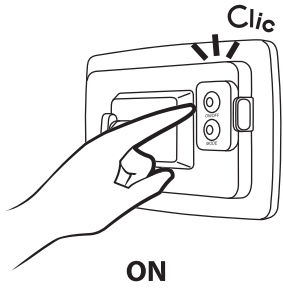

2

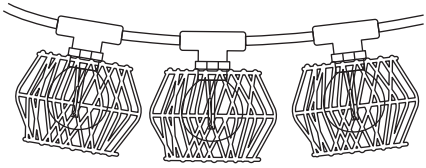

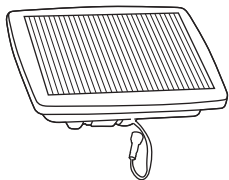

1

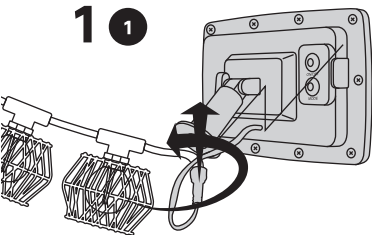

2

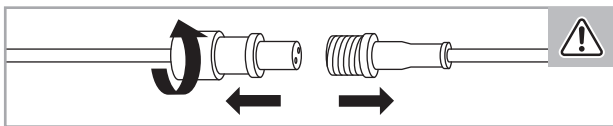
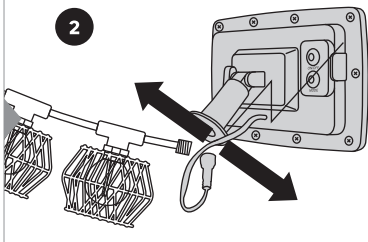

2

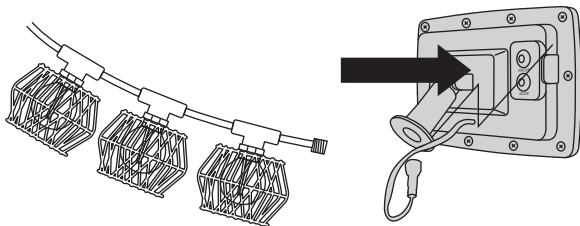

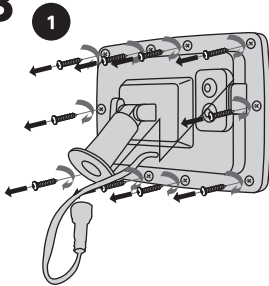
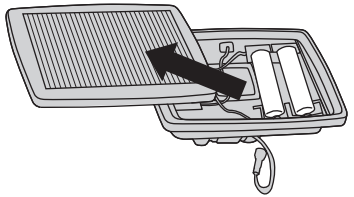
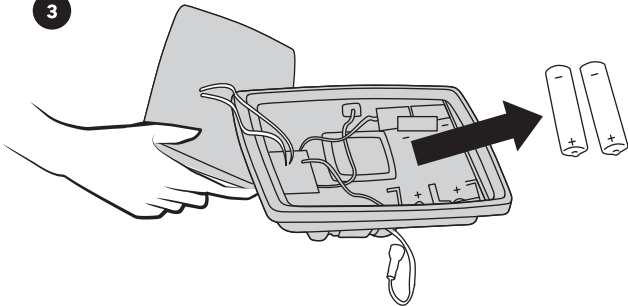
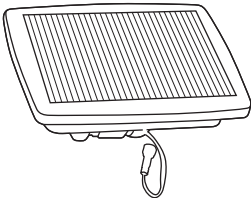
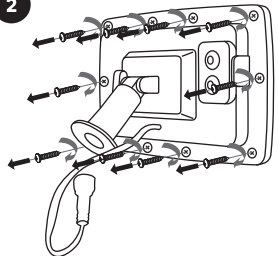
3**2****3****4****1****2**

3

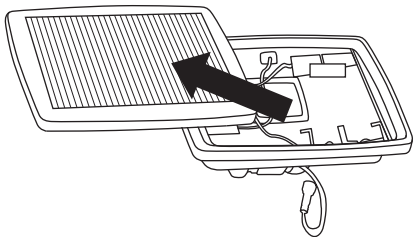

4

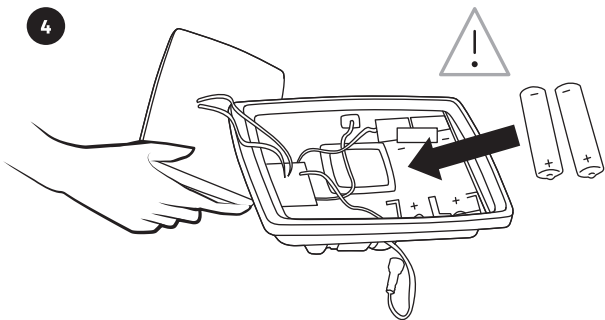

5

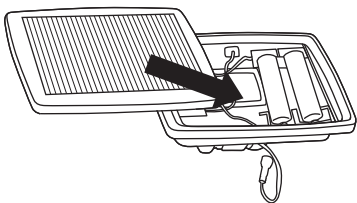

6

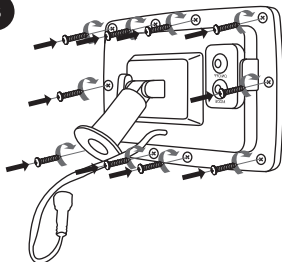

5

1

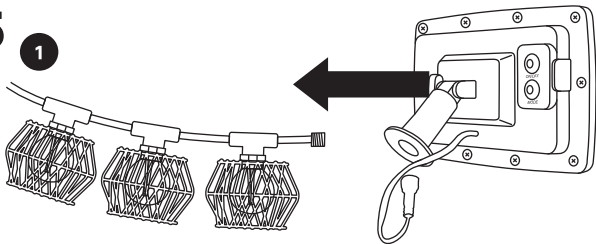

2

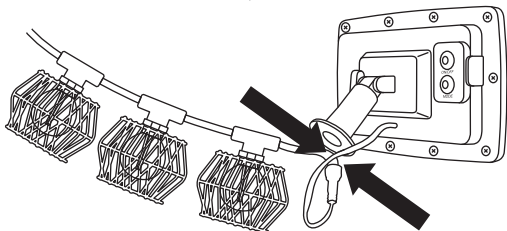

3

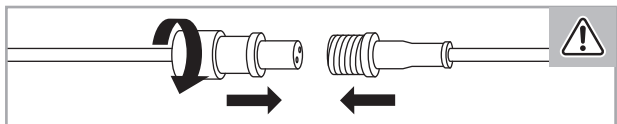
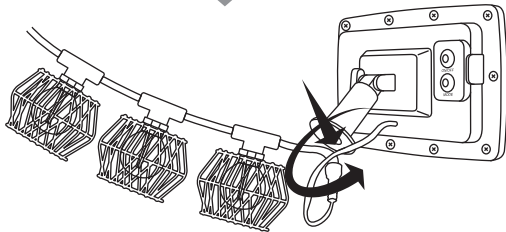

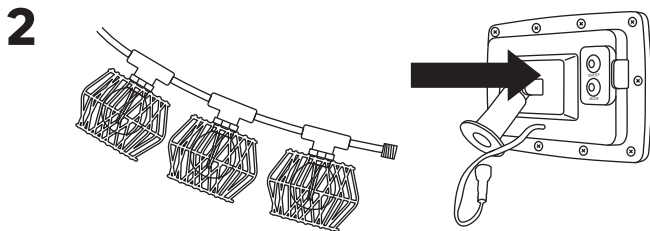
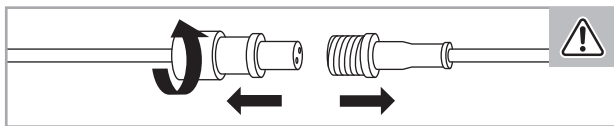
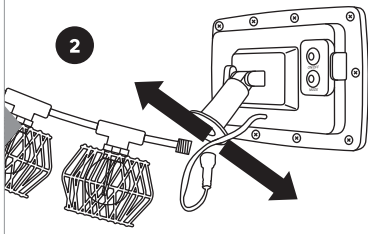
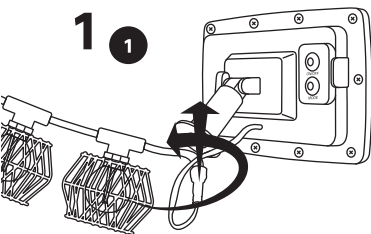
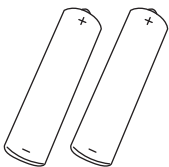

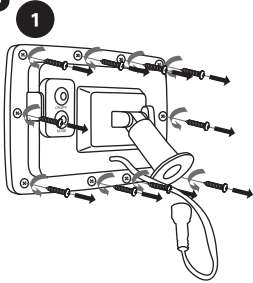
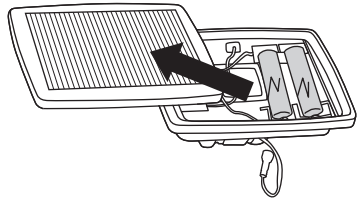
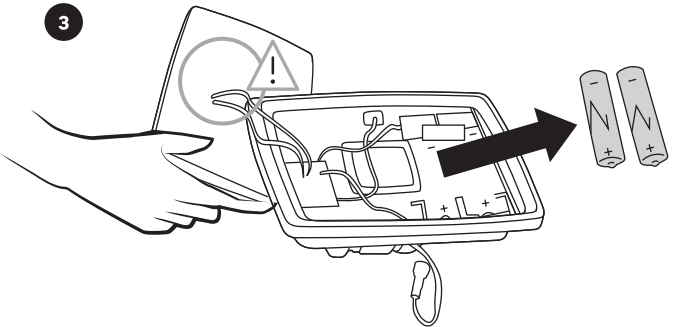
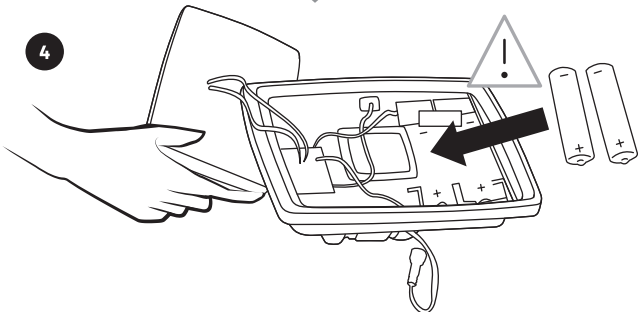
3**2****3****4**

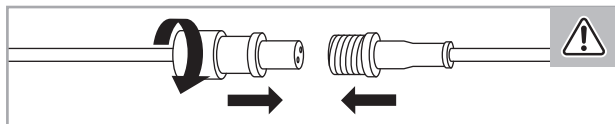
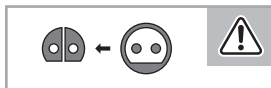
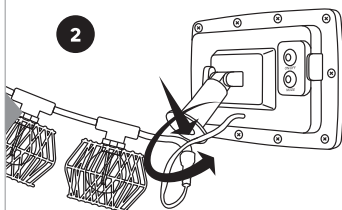
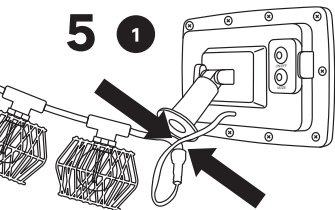
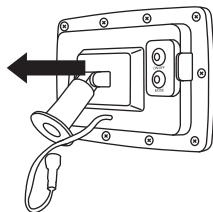
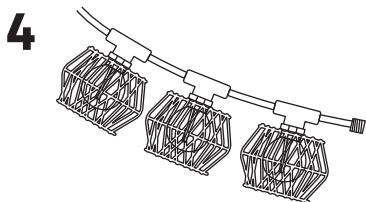
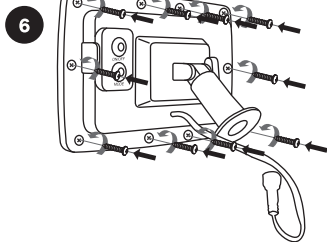
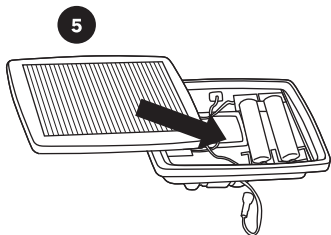

6

1



5min

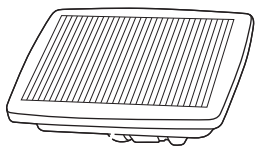

2

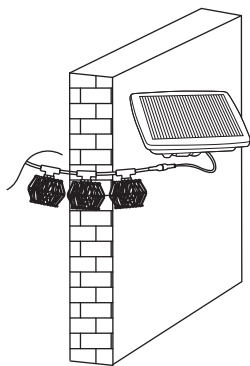



- FR** Ce produit est recyclable. S'il ne peut plus être utilisé, veuillez l'apporter dans un centre de recyclage de déchets.
- ES** Este producto es reciclable. Si ya no se puede usar, llévelo a un centro de reciclaje de residuos.
- PT** Este produto é reciclável. Se deixar de o utilizar, entregue-o num centro de reciclagem de resíduos.
- IT** Questo prodotto può essere riciclato. Se deve essere smaltito, portalo presso un centro di riciclaggio.
- EL** Αυτό το προϊόν είναι ανακυκλώσιμο. Εάν δεν μπορεί πλέον να χρησιμοποιηθεί, μεταφέρετε την σε κάποιο κέντρο ανακύκλωσης απορριμμάτων.
- PL** Ten produkt poddawany jest recyklingowi, kiedy przestaje być użyteczny należy dostarczyć go do punktu zbiórki odpadów.
- UA** Цей продукт може перероблятися. Якщо воно більше не є придатне для використання, здайте його в утилізаційний центр.
- RO** Acest produs este reciclabil. Dacă nu mai poate fi folosit, vă rugăm să îl aduceți într-un centru de reciclare a deșeurilor.
- BR** Este produto é reciclável. Se não puder mais ser usado, descarte em um centro de reciclagem de resíduos.
- DE** Dieses Produkt ist recycelbar. Wenn es nicht mehr verwendet werden kann, bringen Sie es bitte zum Recycling-Center.
- EN** This product is recyclable. If it cannot be used anymore, please take it to waste recycling centre.



IT Raccolta Carta, verifica le disposizioni del tuo Comune.

Made in China
Країна походження: Китай

EU - ADEO Services - 135 Rue Sadi Carnot - CS00001 - 59790 RONCHIN - FRANCE

www.product-regulatory.adeoservices.com

UA Виробник: ТОВ "Адео Сервісес С.А.", вул. Саді Карно, СС 00001, 59790 Роншін, Франція.
Імпортер: ТОВ "Леруа Мерлен Україна", 04201 Україна, м.Київ, вул. Полярна 17А, +380 44 498 46 00. Імпортер приймає претензії від споживачів щодо товару, а також проводить його ремонт, технічне і гарантійне обслуговування

BR LEROY MERLIN COMPANHIA BRASILEIRA DE BRICOLAGEM CNPJ: 01.438.784/0001-05
Rua Pascoal Pais, nº. 525, 6º andar cj 61 a 64, Vila Cordeiro, São Paulo -SP. CEP: 04581-060
CALM (Central de Atendimento Leroy Merlin) Capitais 4020-5376 Demais Regiões 0800-0205376

ZA Imported by Adeo South Africa (PTY) LTD T/A Leroy Merlin,
Hosted in Leroy Merlin Fourways Store 35 Roos Street, Witkoppen Ext 97, Sandton, 2191 Johannesburg, Gauteng, South Africa.
Tel: +27 10 493 8000 Email: contact@leroymerlin.co.za.