

Montagefolge  
Assembly steps

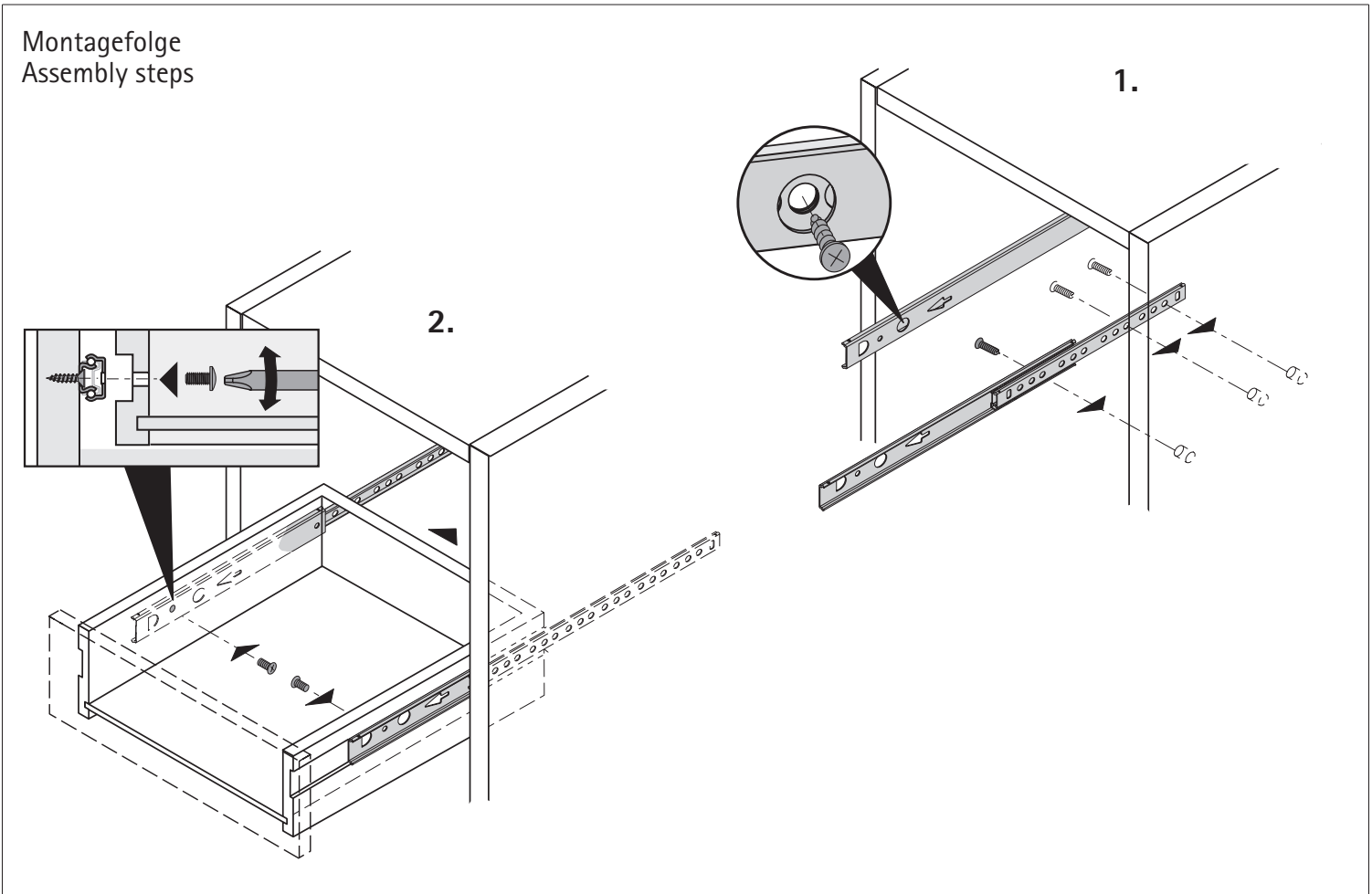

KA 1730

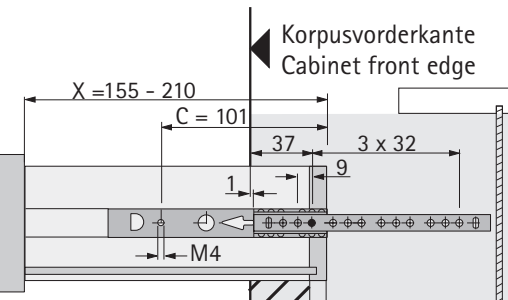

KA 1730/200

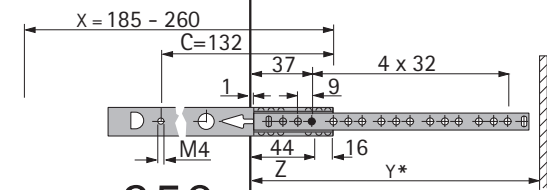

KA 1730/250

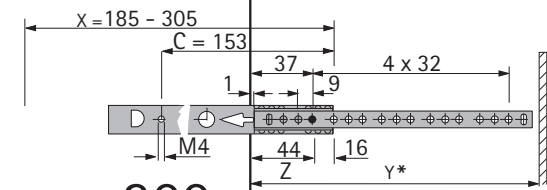

KA 1730/300

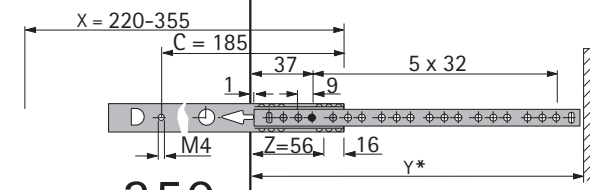

KA 1730/350

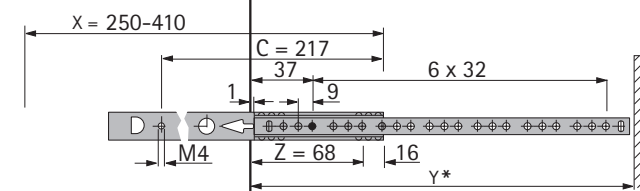

KA 1730/400

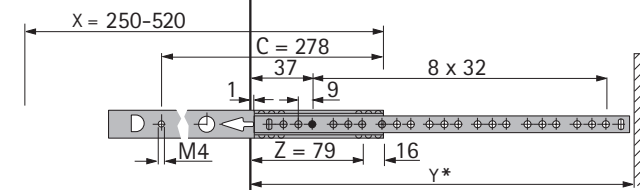

KA 1730/500

KA 1730 mit Frontabstützung  
KA 1730 with front support

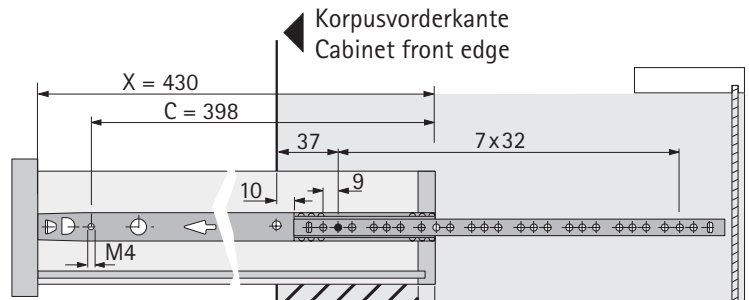

KA 1730/430

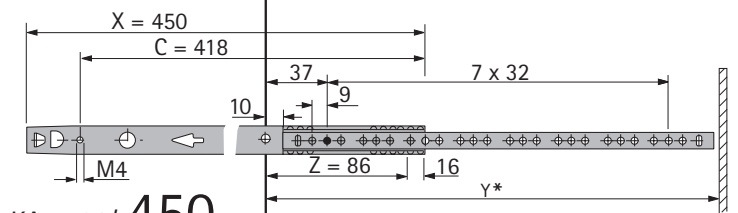

KA 1730/450

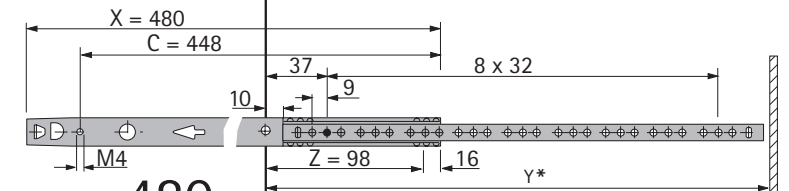

KA 1730/480

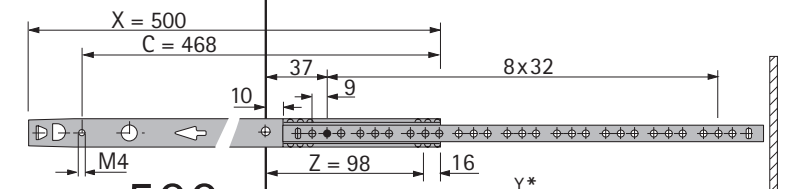

KA 1730/500

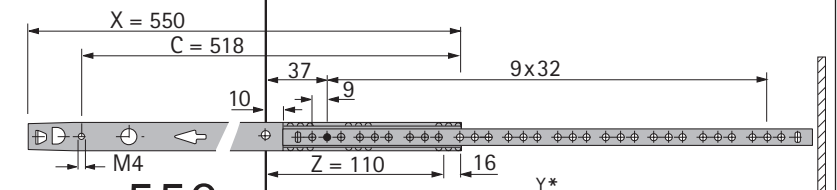

KA 1730/550

C = Lochabstand  
Hole distance

X = Schubkastenlänge  
Drawer length

Y = Mindestkorpustiefe  
Min. cabinet depth

Z = Auszugsverlust  
Extension loss

\* Mindestkorpustiefe = Schubkastenlänge + 1 mm  
\* Min. cabinet depth = Drawer length + 1 mm