

METAL SHED

GALVANIZED STEEL
0,3MM APEX ROOF 2.1M²

10
YEAR
Warranty*

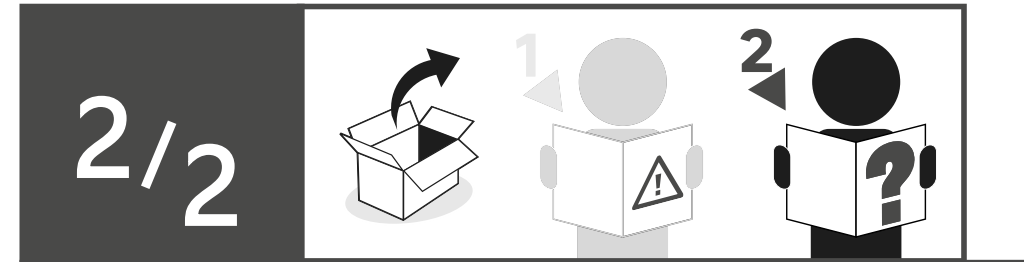
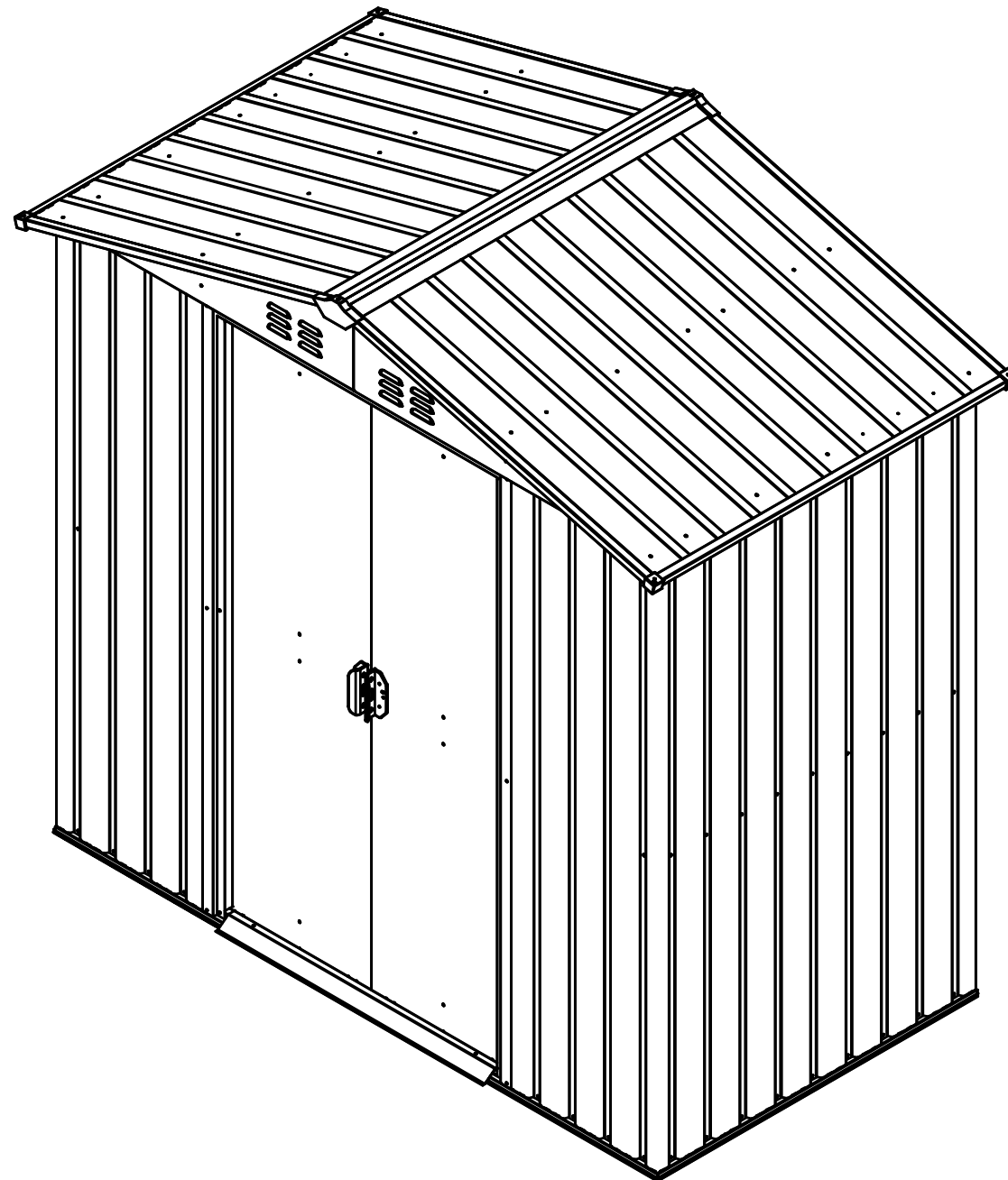

EAN :3276007881288
MATRIX ID :2025R09P11-0020

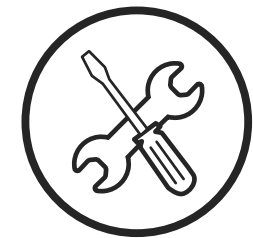

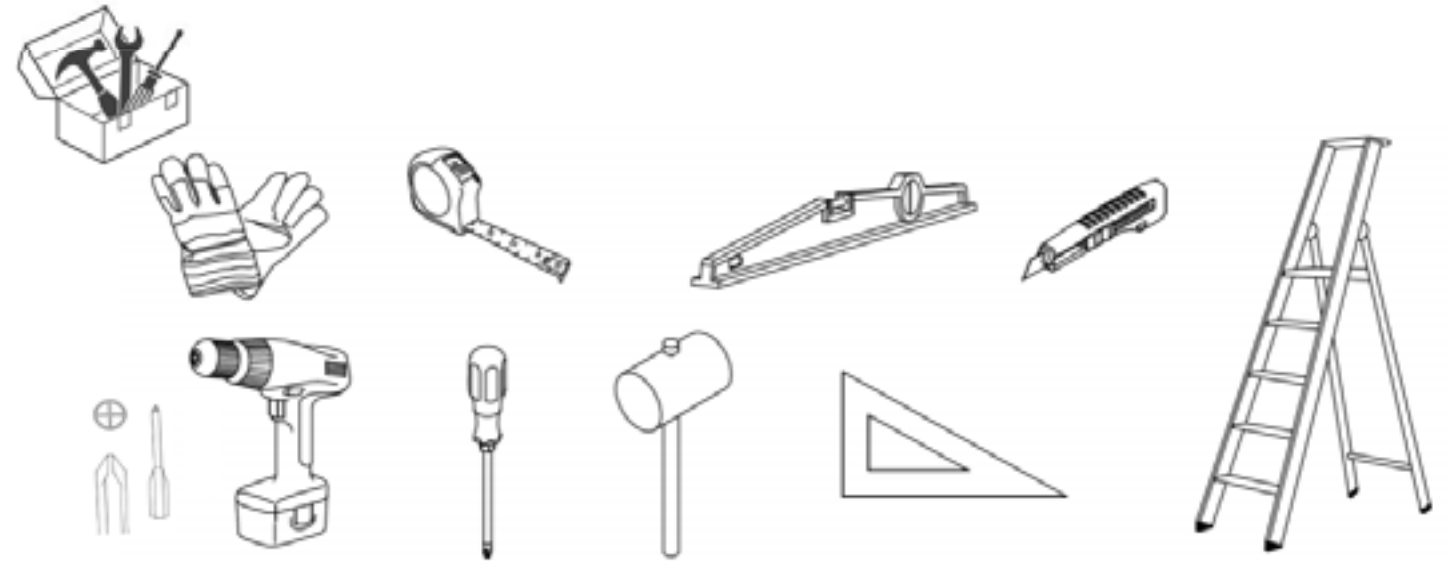

max.75kg/ m²

max.90km/h

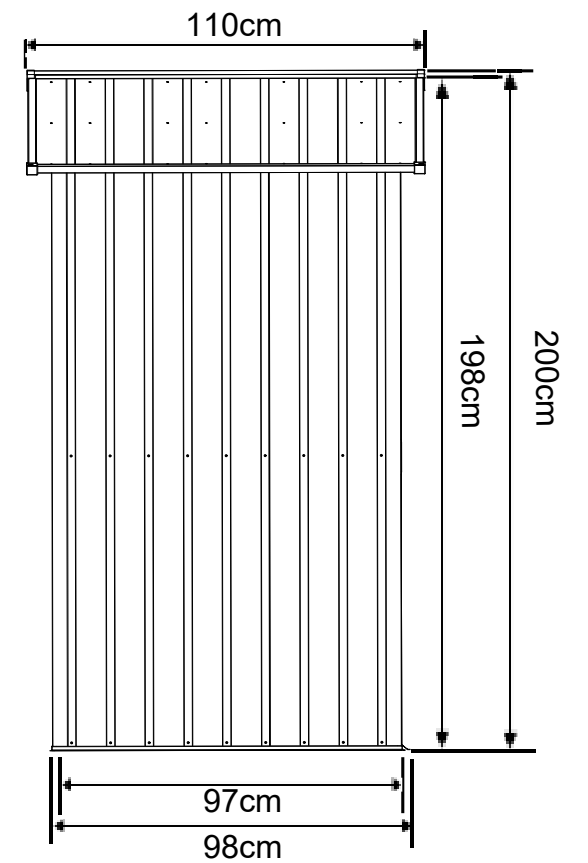
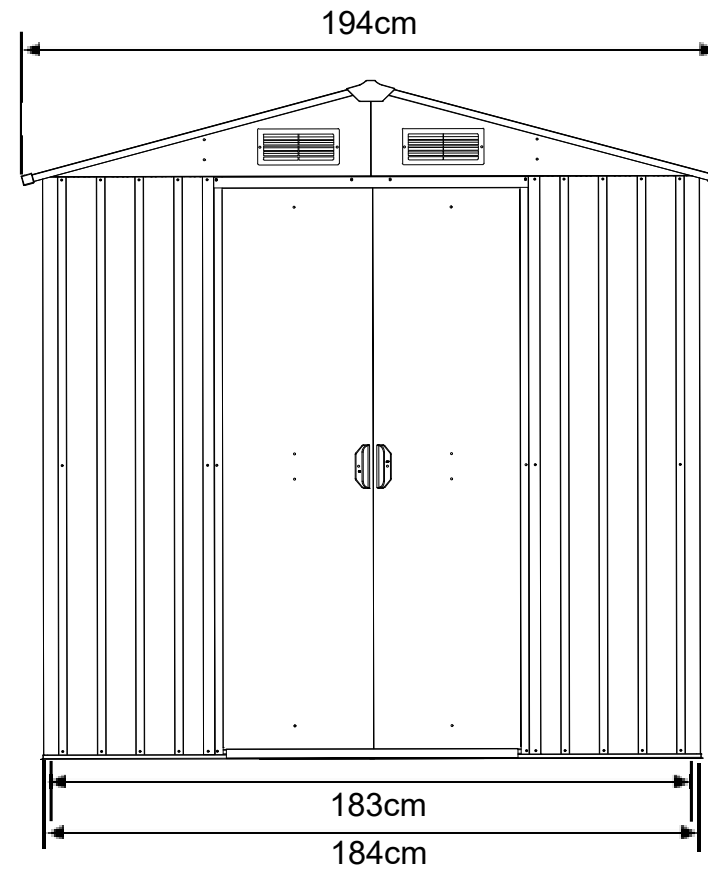







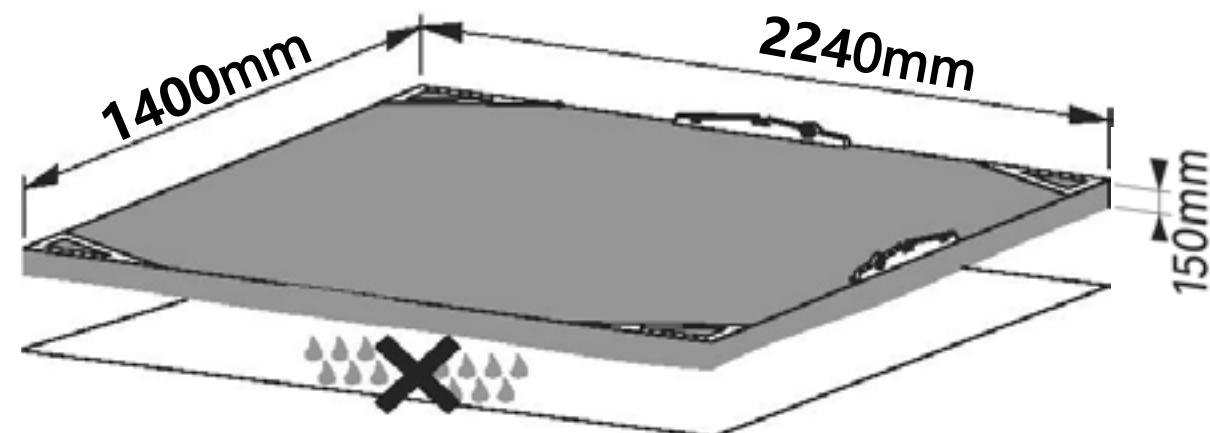













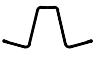













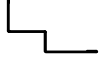

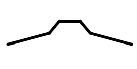





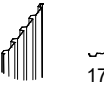
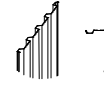
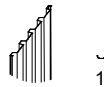

FR Sol nivelé requis	ES Es necesario un suelo nivelado	PT É necessário um solo nivelado
IT È richiesto un fondo livellato	EL Απαιτείται επίπεδο έδαφος	PL Wymagane wyrównanie i wypoziomowanie podłoża
UA Необхідно забезпечити рівну ділянку землі	RO Necesar teren plat	EN Level ground required



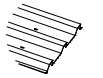
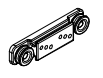



- [ER] Pose sur dalle béton parfaitement plate et de niveau (non incluse)
- [ES] Colocar sobre losa de hormigón perfectamente plana y nivelada (non incluida)
- [PT] Montagem sobre laje de betao perfeitamente plana e nivelada (não incluída)
- [IT] Posare su pavimenti in cemento perfettamente in piano e livellato (non incluso)
- [EL] Πρέπει να τοποθετείται πάνω σε απόλυτα επίπεδη και οριζόντια πλάκα σκυροδέματος (δεν περιλαμβάνεται)
- [PL] Montaż na idealnie płaskiej i wypoziomowanej płycie betonowej (brak w zestawie)
- [UA] Укладання на ідеально рівну і вирівняну бетонну плиту (не входить у комплект)
- [RO] Montare pe dală de beton perfect plată și la nivel (nu este inclusă)
- [BR] Instalação em uma laje de concreto perfeitamente plana e nivelada (não incluída).
- [EN] Installed on a perfectly flat and level concrete slab (not included)

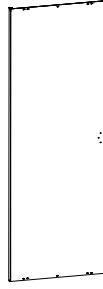
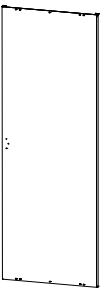

NO.	PART	Qty.
1L	 966mm	1
1R	 966mm	1
2L	 955mm	1
2R	 955mm	1
3L	 600mm	1
3R	 600mm	1
5	 808mm	1
7	 891mm	1
8	 891mm	1
9	 926mm	1
11	 926mm	1
10L	 904mm	1
10R	 904mm	1
16	 973mm	1
12	 353.5mm	2
J1		4

NO.	PART	Qty.
22L	 932mm	1
22R	 932mm	1
23L	 904mm	1
23R	 904mm	1
B3	 230mm	2
B4	 230mm	2
17	 958mm	4
15	 1088mm	2
4L	 1720mm	1
4R	 1720mm	1
6	 876mm	1
18	 456mm	6
19	 1090mm	1
21L		2
21R		2
6-1	 866mm	1
6-2	 931mm	1

NO.	PART	Qty.
P1	 1720mm	2
P2	 1720mm	1
P4	 1720mm	2
P3	 1720mm	2
P9	 1720mm	2
P5	 986mm	1
P6	 986mm	1
P10	 986mm	1
P11	 986mm	1
G2		4
GD		4
GB		2
GC		4
GE		2
GS		4

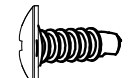
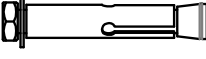
NO.	PART	Qty.
D1	 1710X460mm	1
D2	 1710X460mm	1
F1	 ST4.2X10mm	225
F2	 M4X10mm	30
F3	 ST4.8X16mm	8
S2		160
S3		204
F7		16
F10		4

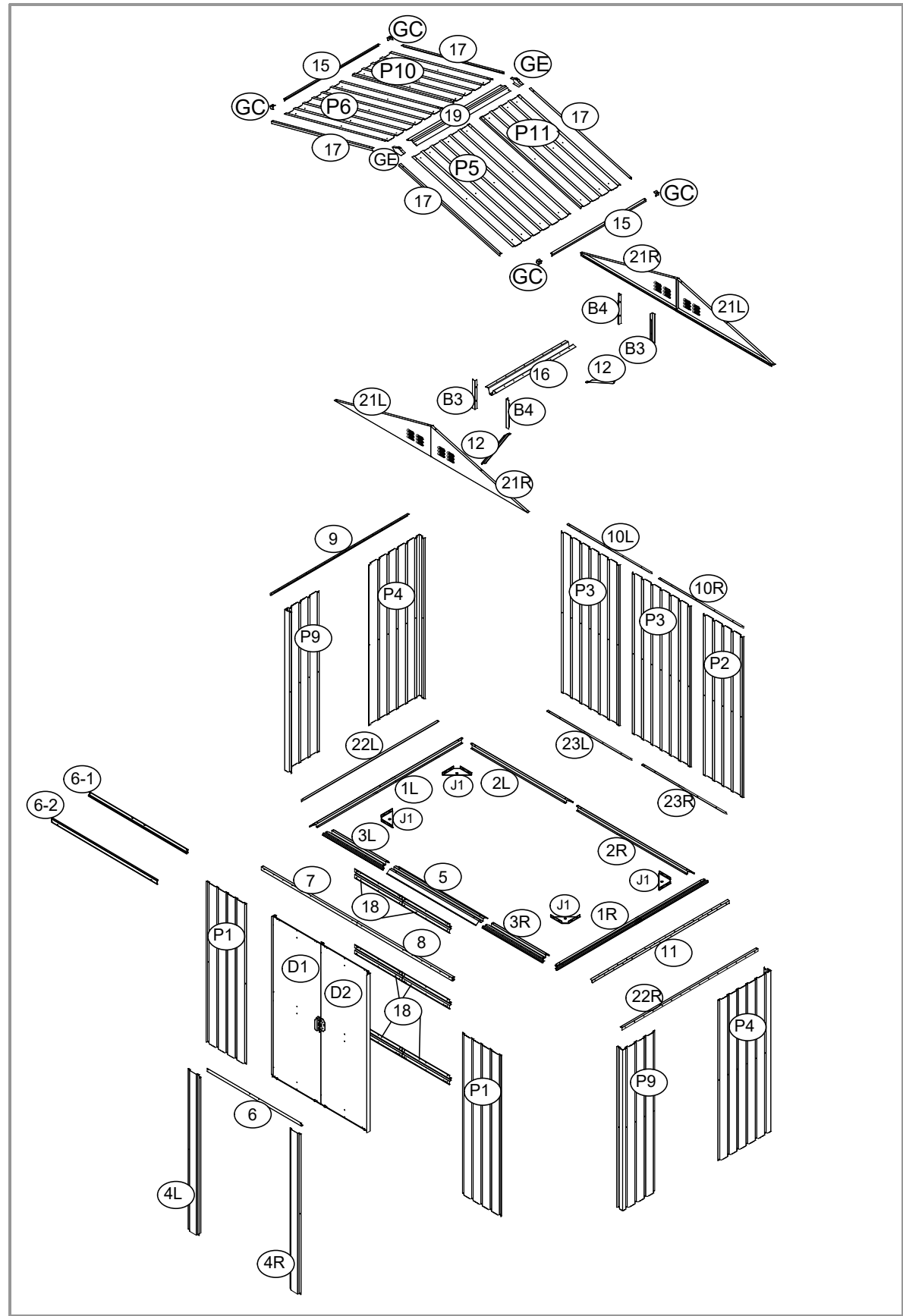

01

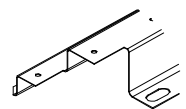

2L (×1)

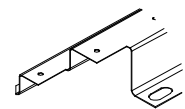

2R (×1)



F1 (×4)

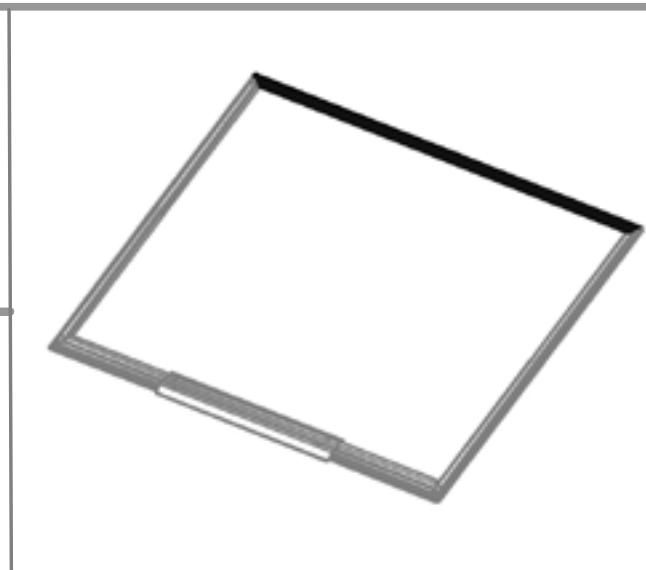

01

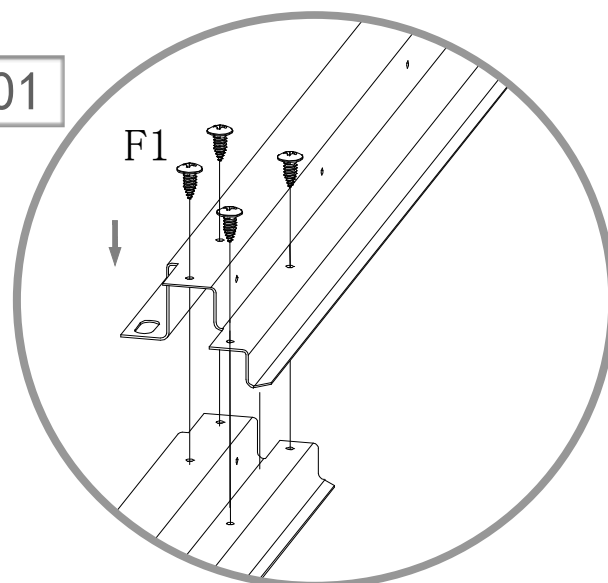

02

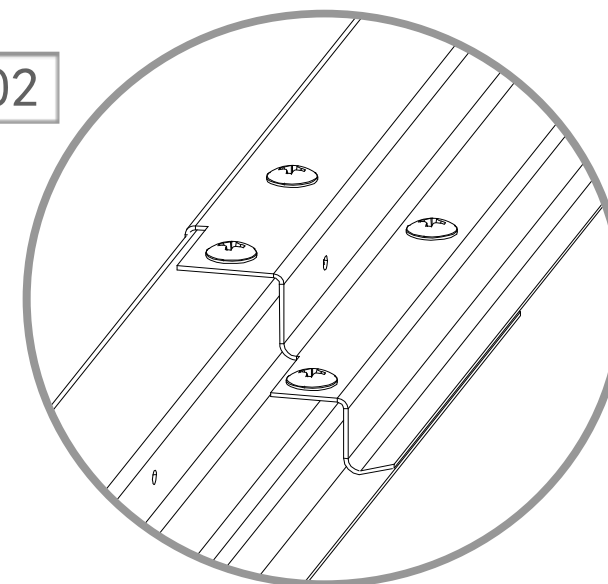

2L

2R

02

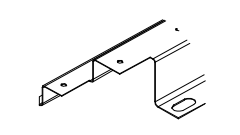

1L (×1)

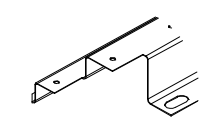

1R (×1)

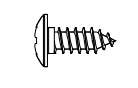

F1 (×4)



01

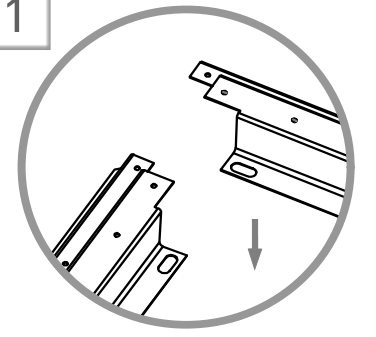

02

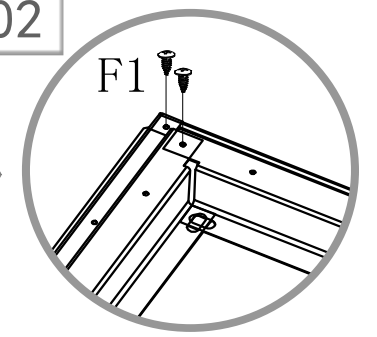

03

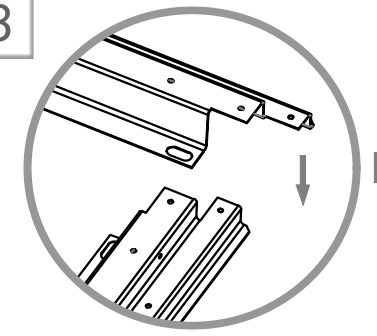

04

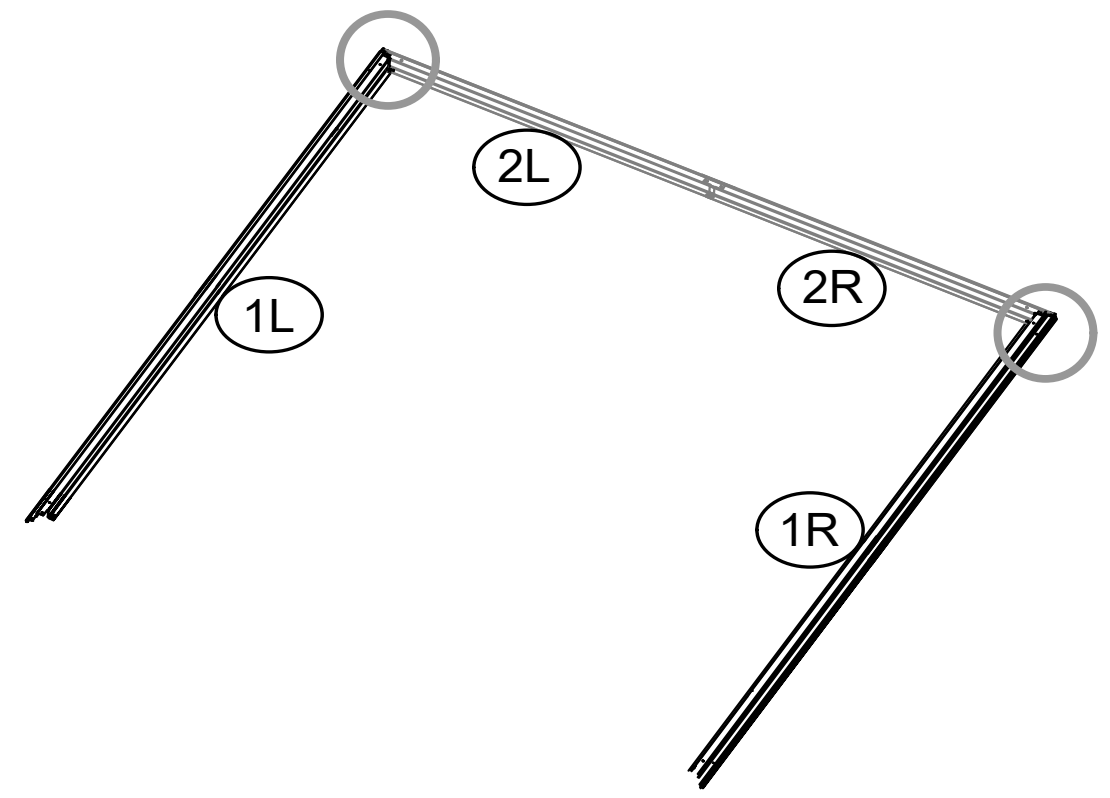
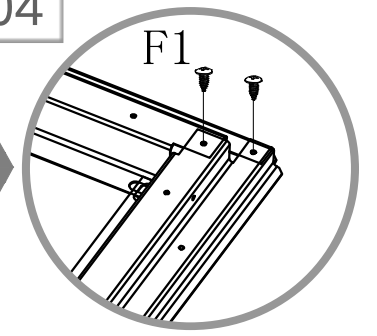

03

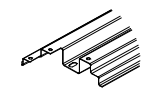

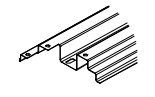
3L (×1)

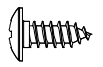
3R (×1)

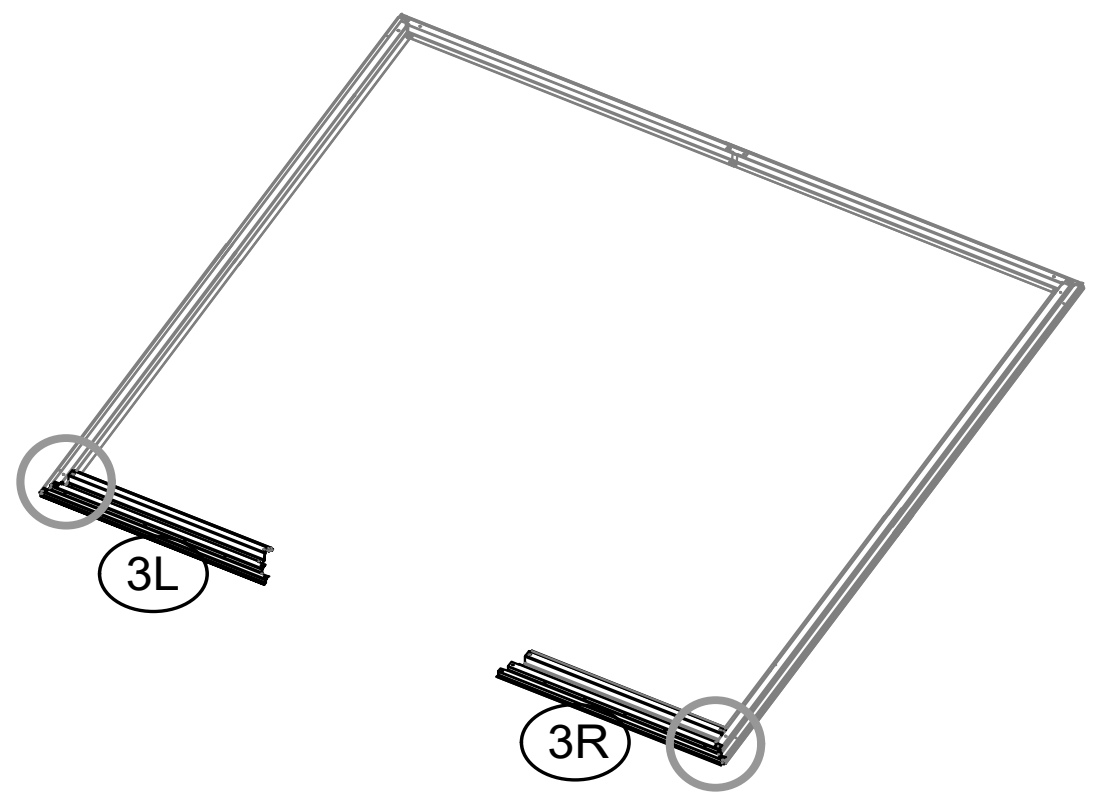
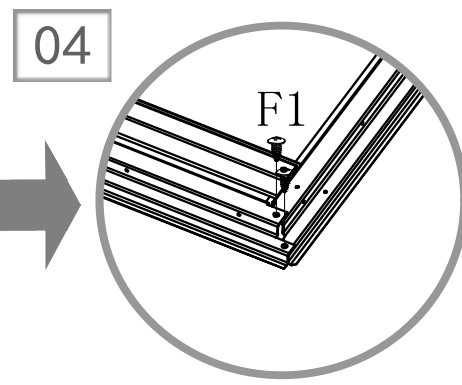
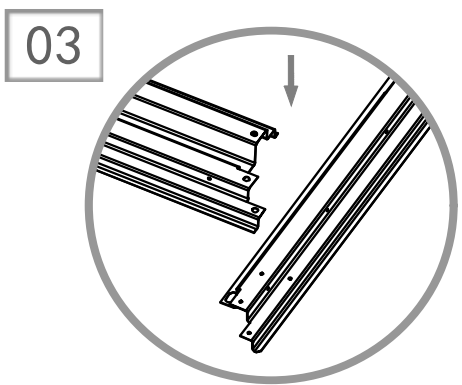
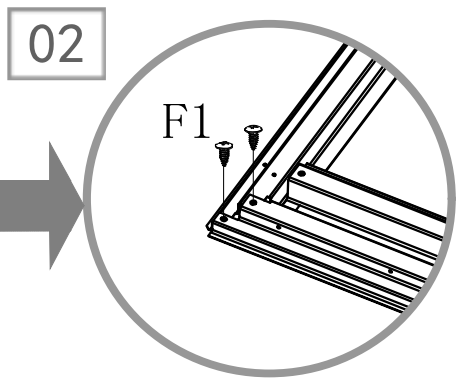
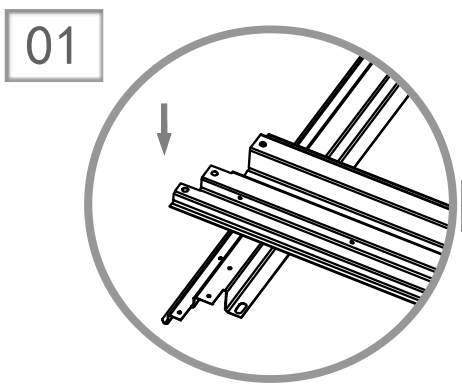

F1 (×4)

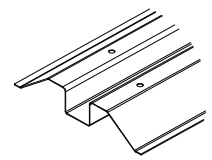

04

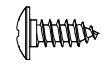

5 (×1)



F1 (×4)

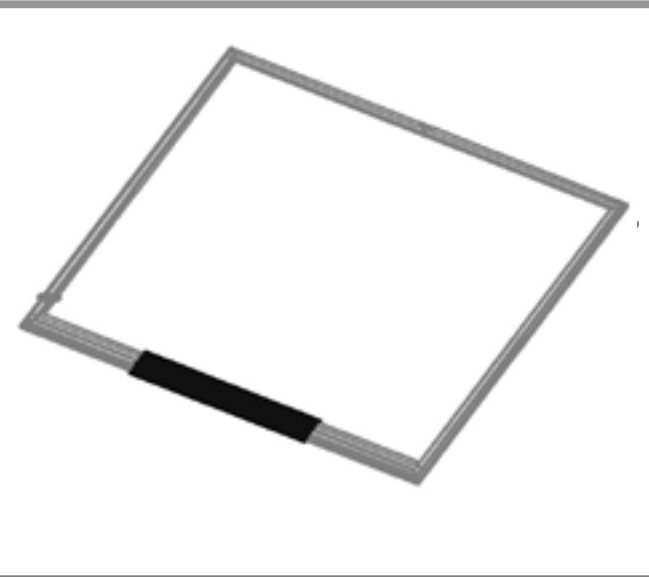

01

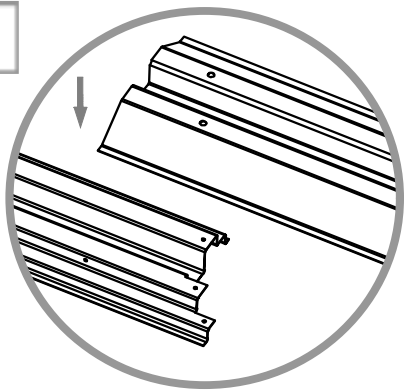

02

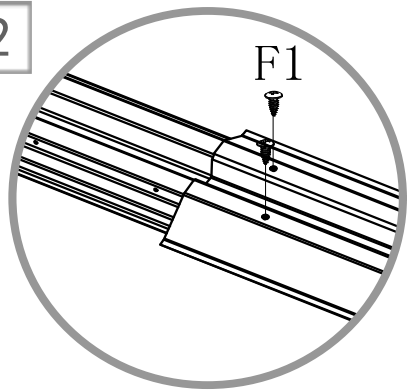

03

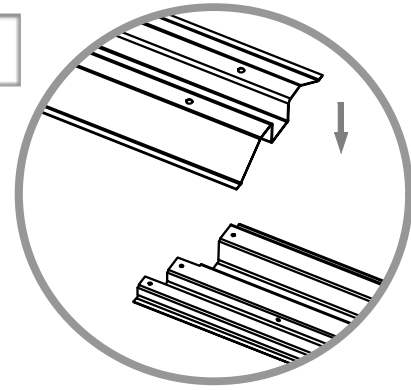

04

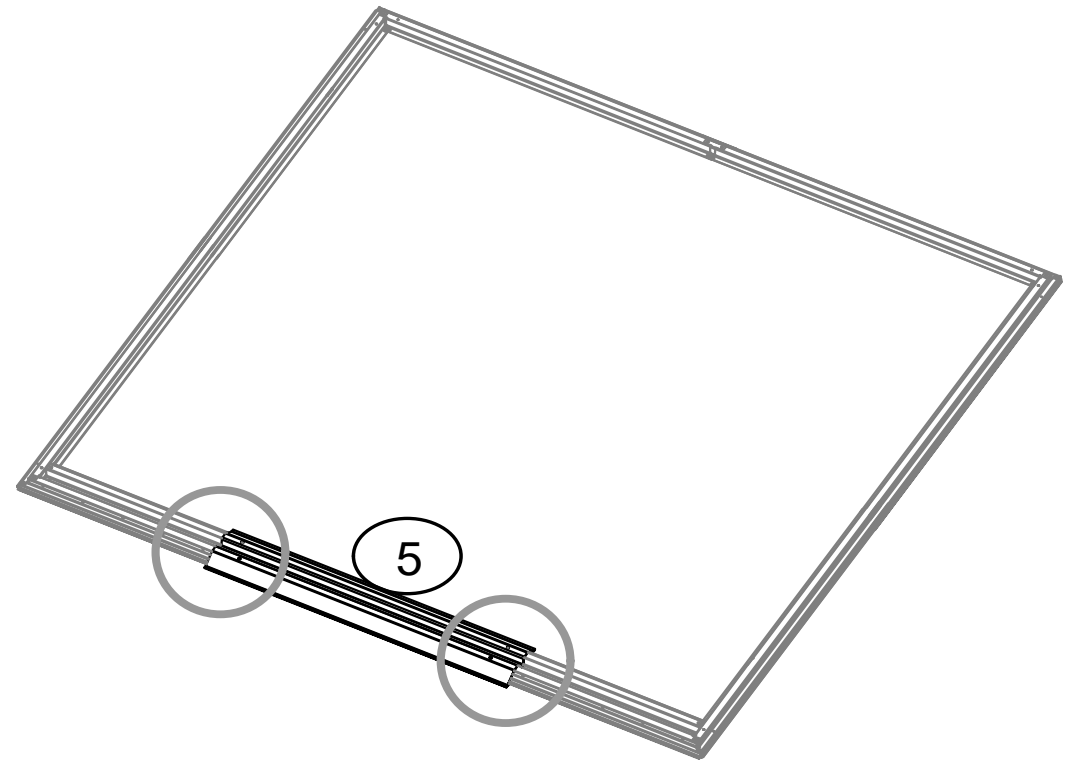
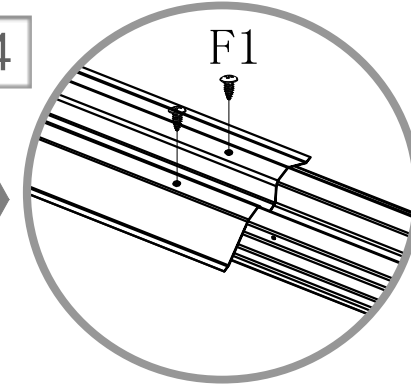

05

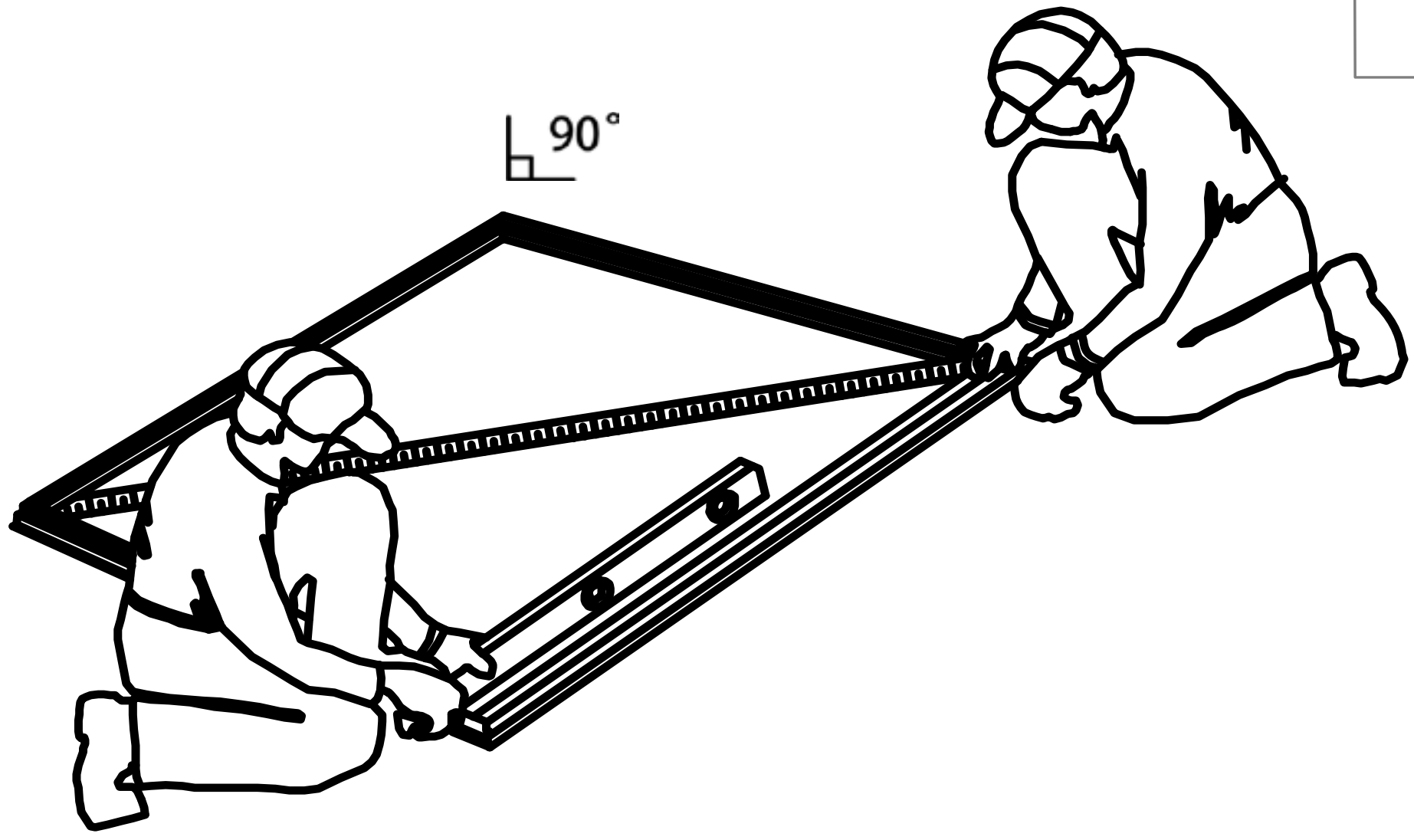
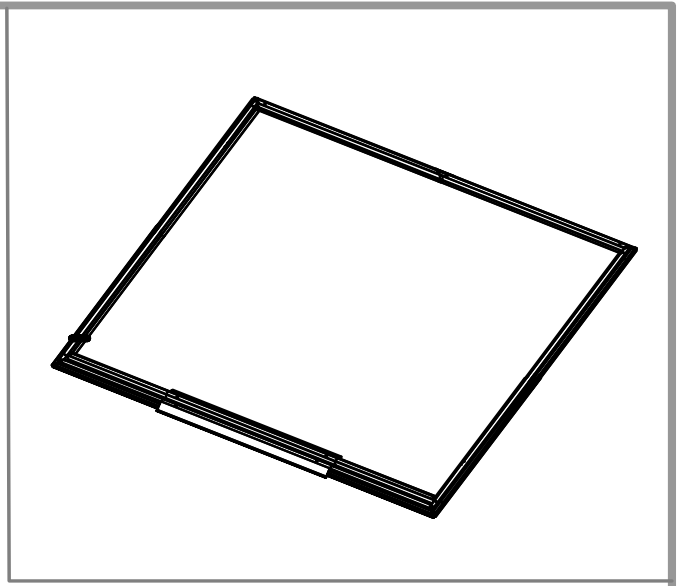

06



P1 (×1)



P9 (×1)

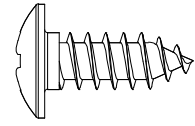

F1 (×7)

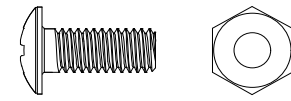

F2 (×1)

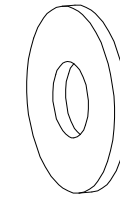

S3 (×7)

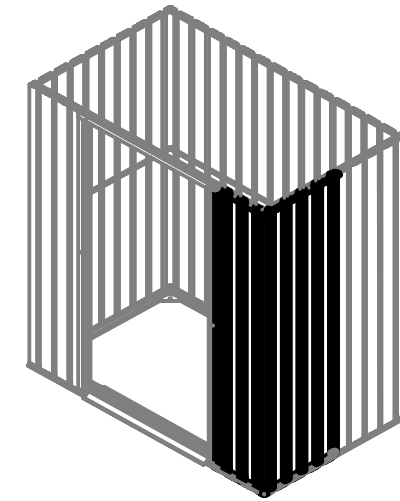

01

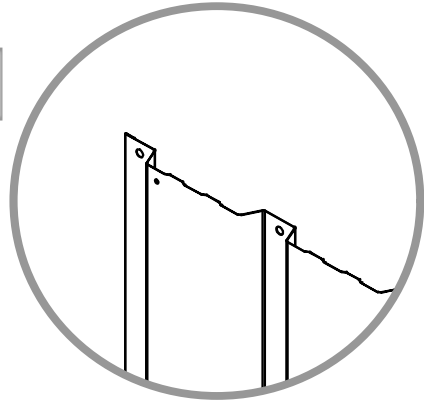

02

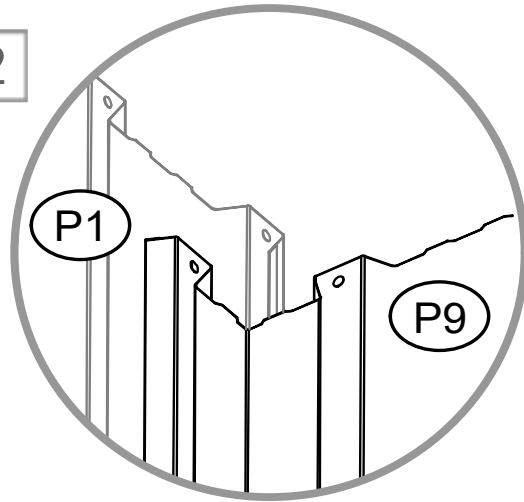

03

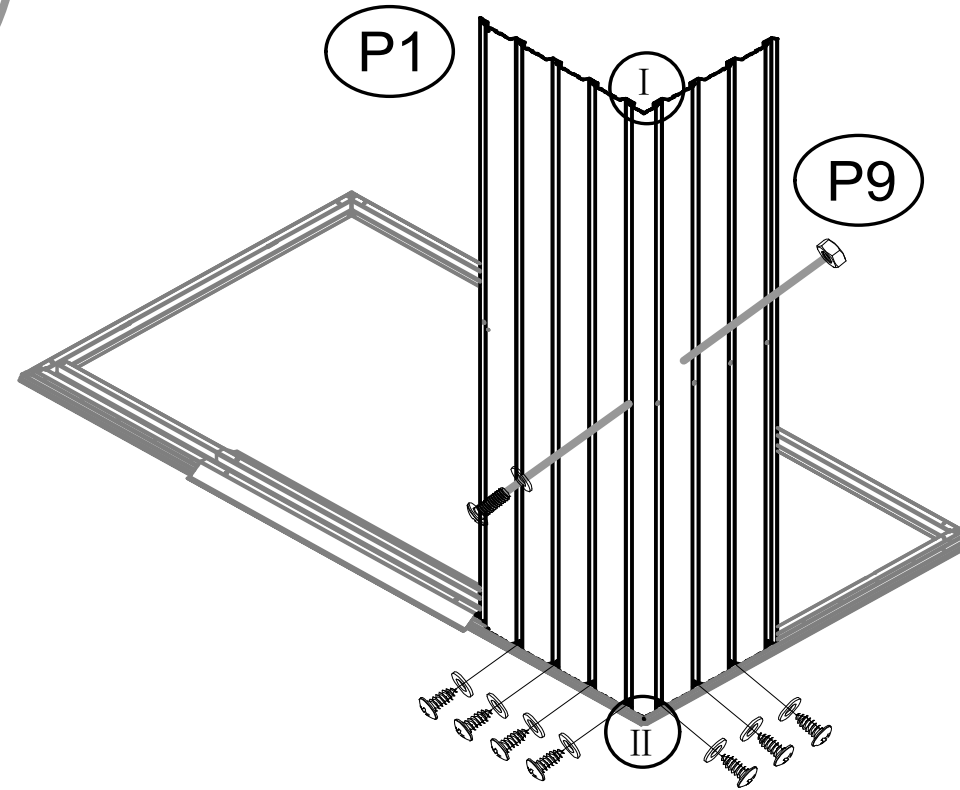
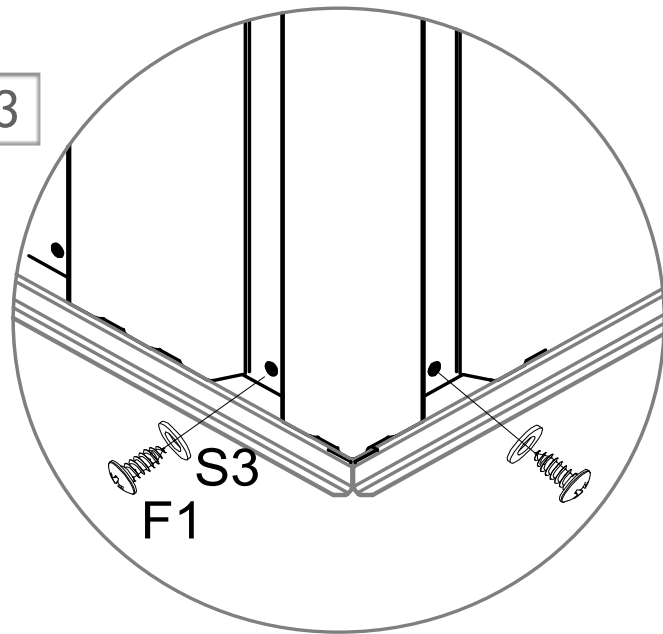

07



22R (× 1)

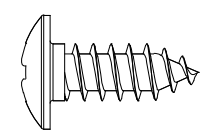

F1 (× 3)

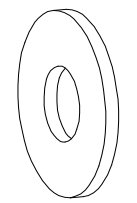

S3 (× 3)

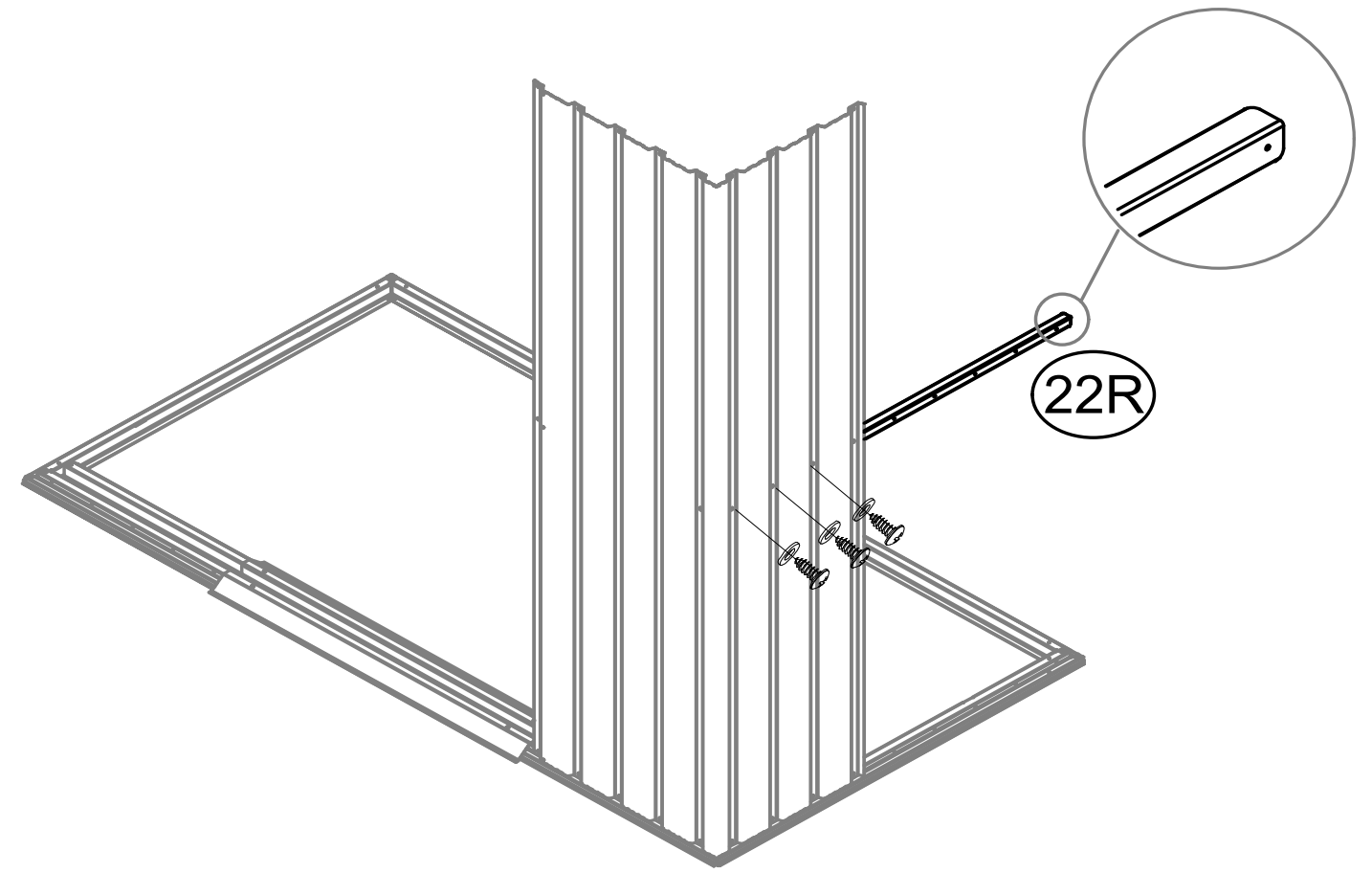
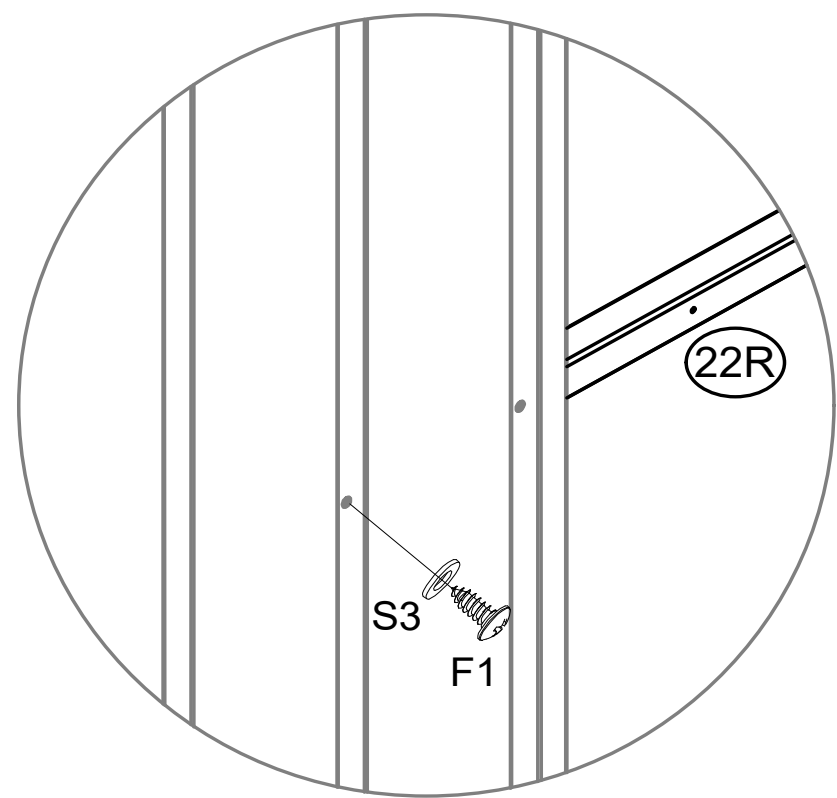
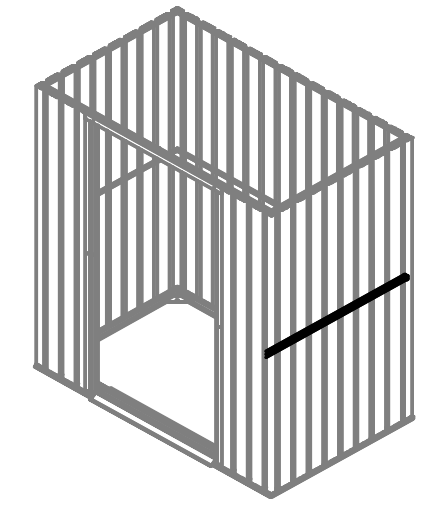

08

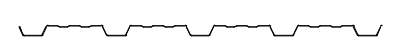

P2 (×1)



P4 (×1)

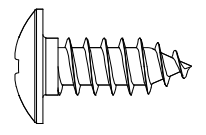

F1 (×16)

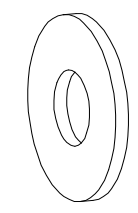

S3 (×16)



01

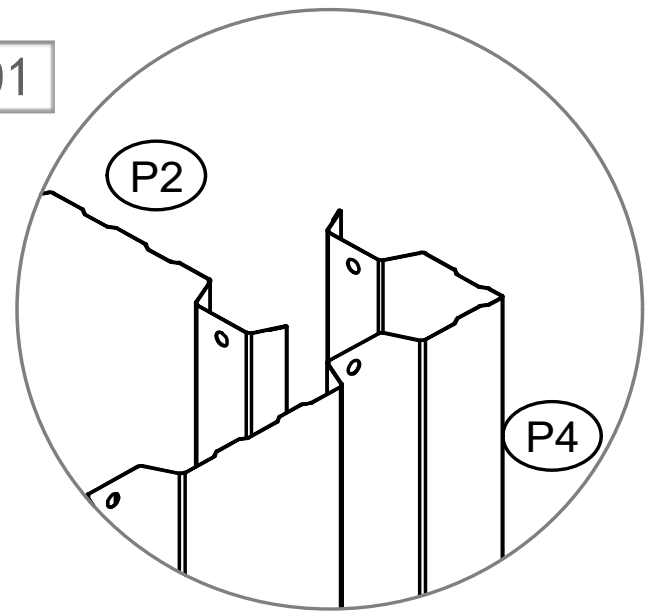

02

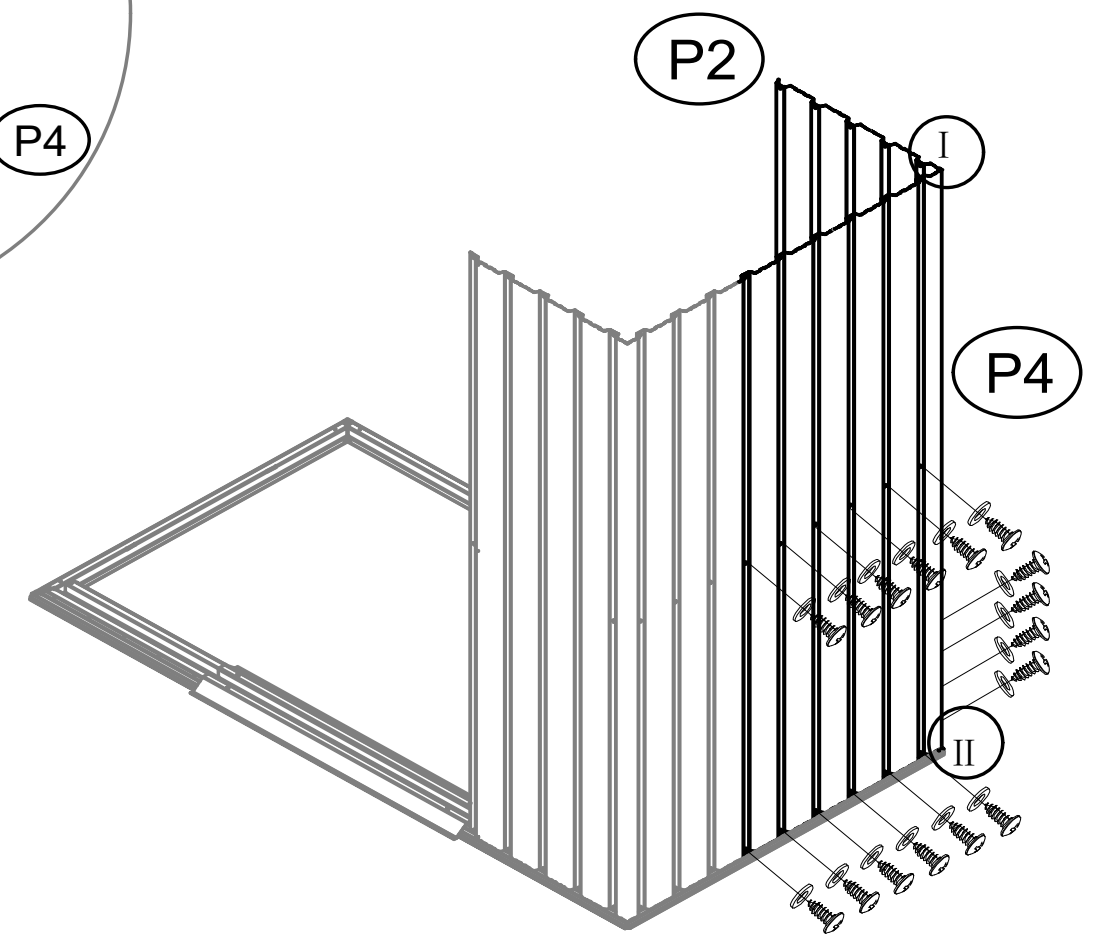
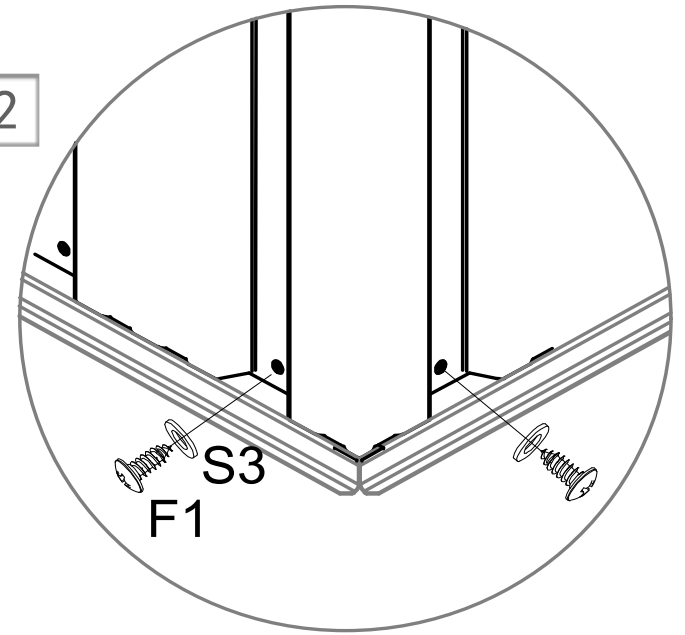

09



23R (×1)

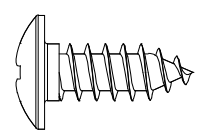

F1 (×4)

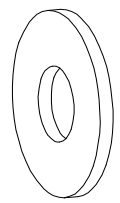

S3 (×4)

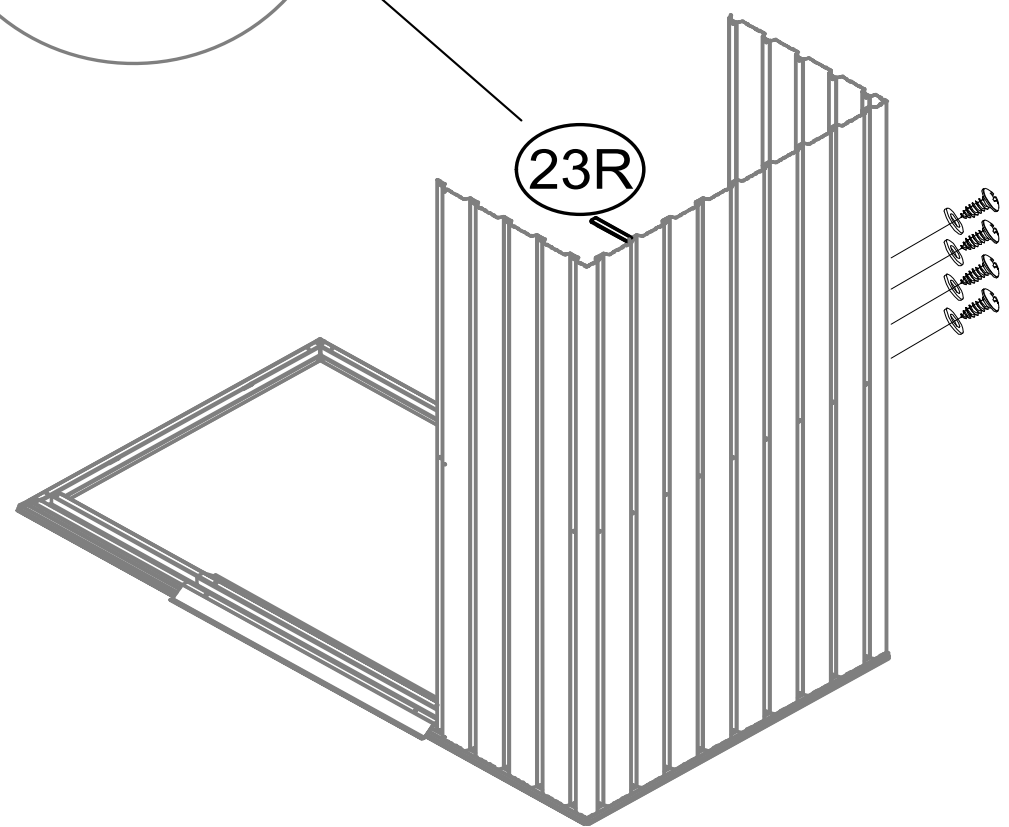
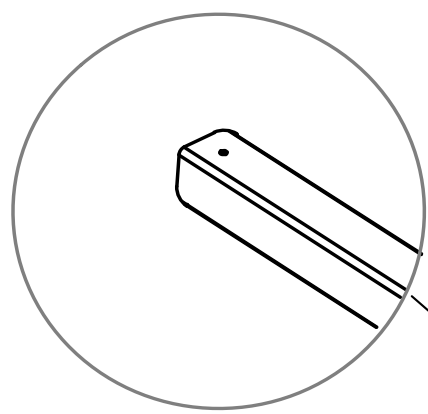
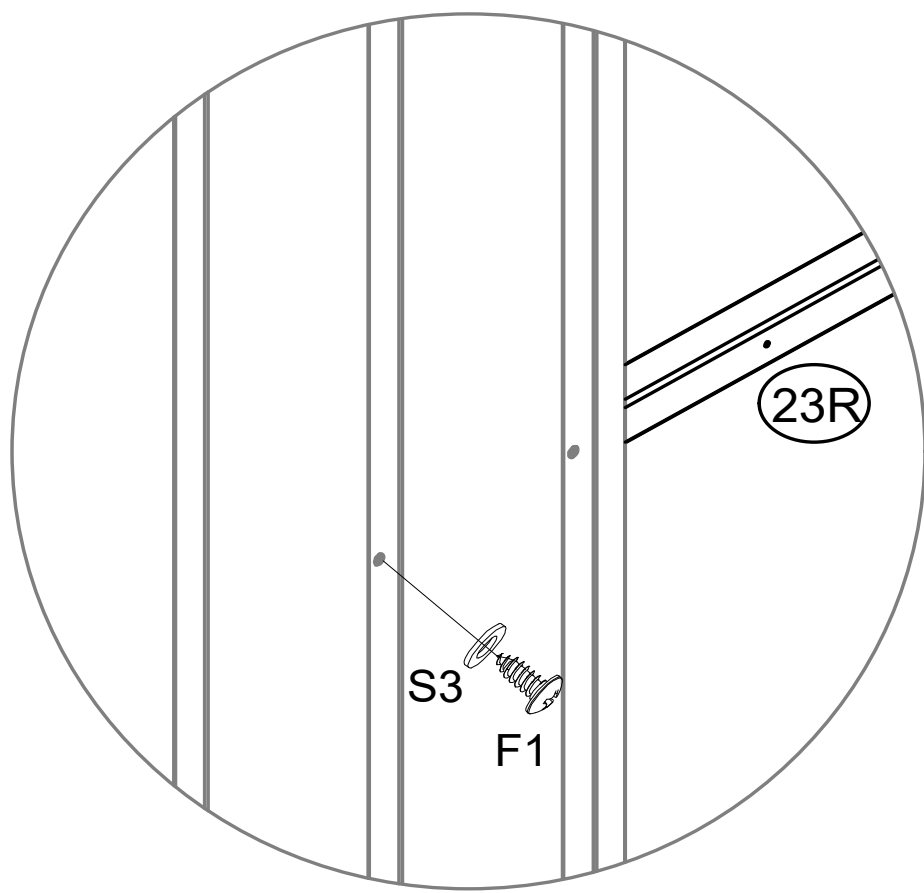
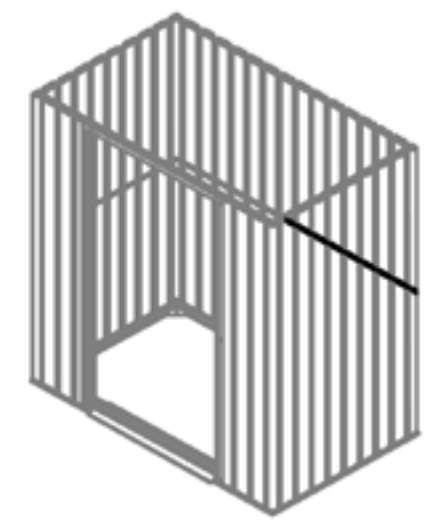

10

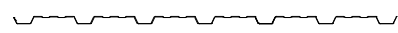

P3 (×1)



P4 (×1)

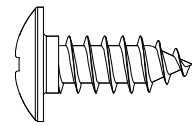

F1 (×11)

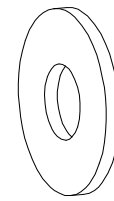

S3 (×11)



01

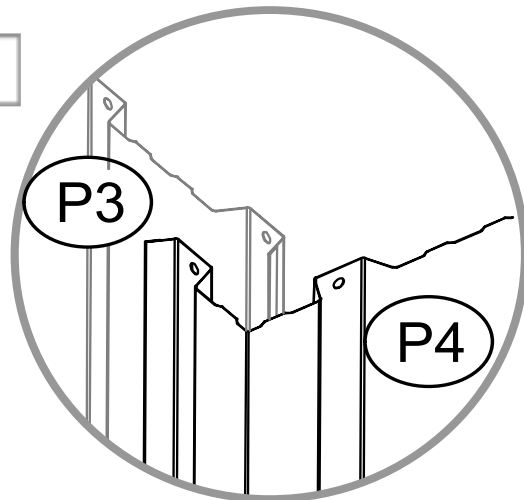

02

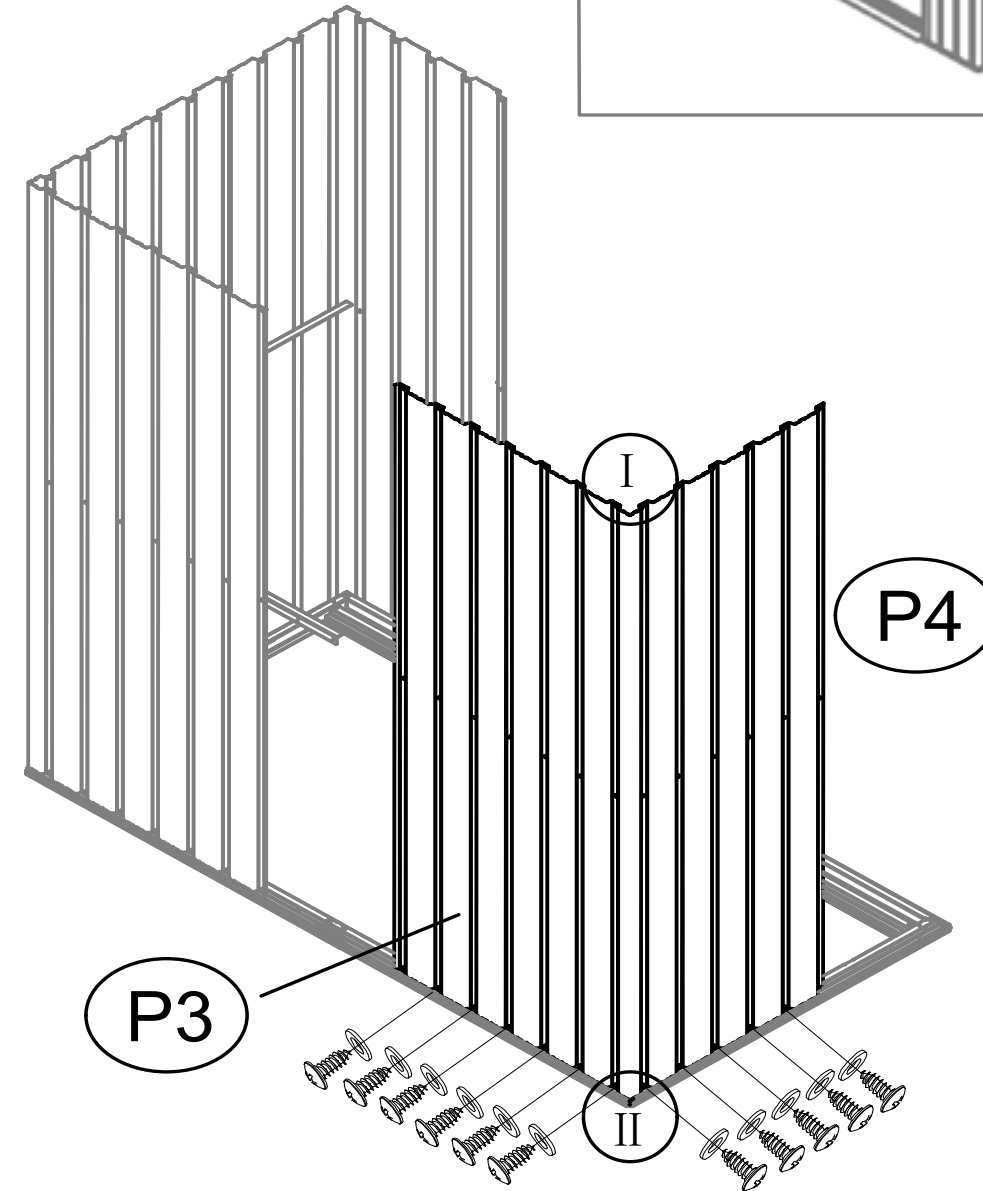
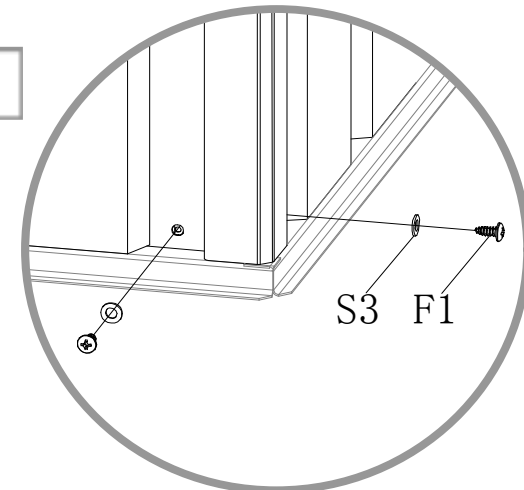

11

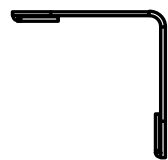

23L (×1)

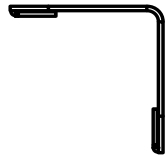

22L (×1)

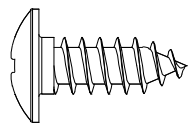

F1 (×11)

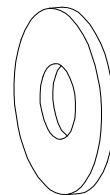

S3 (×11)



01

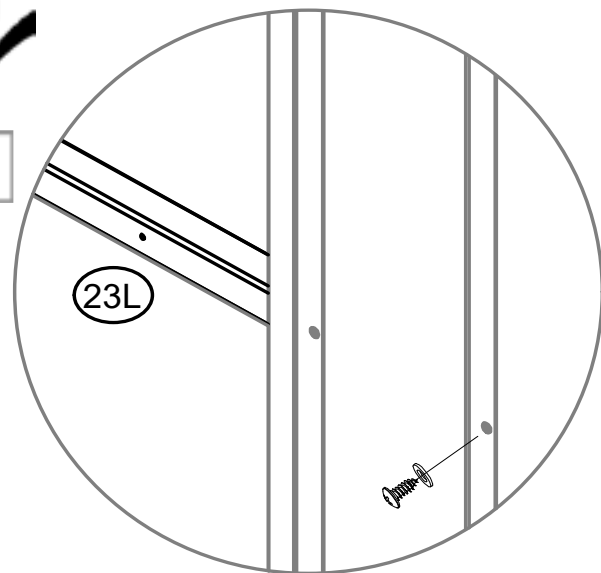

02

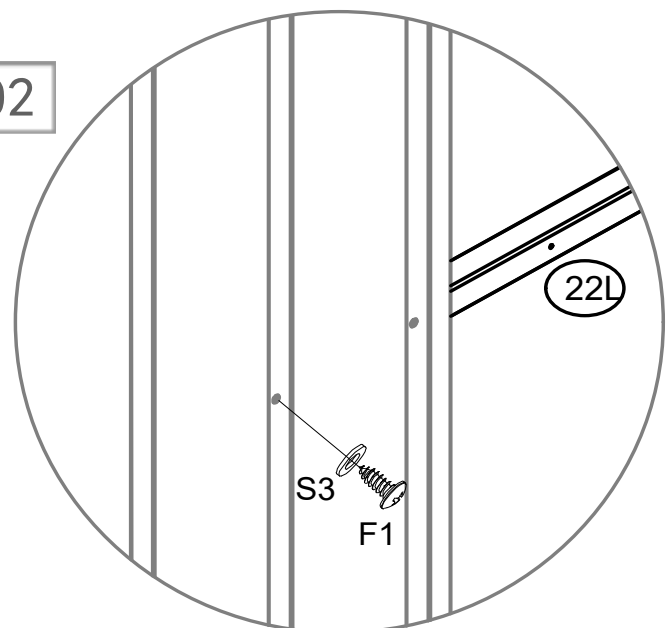

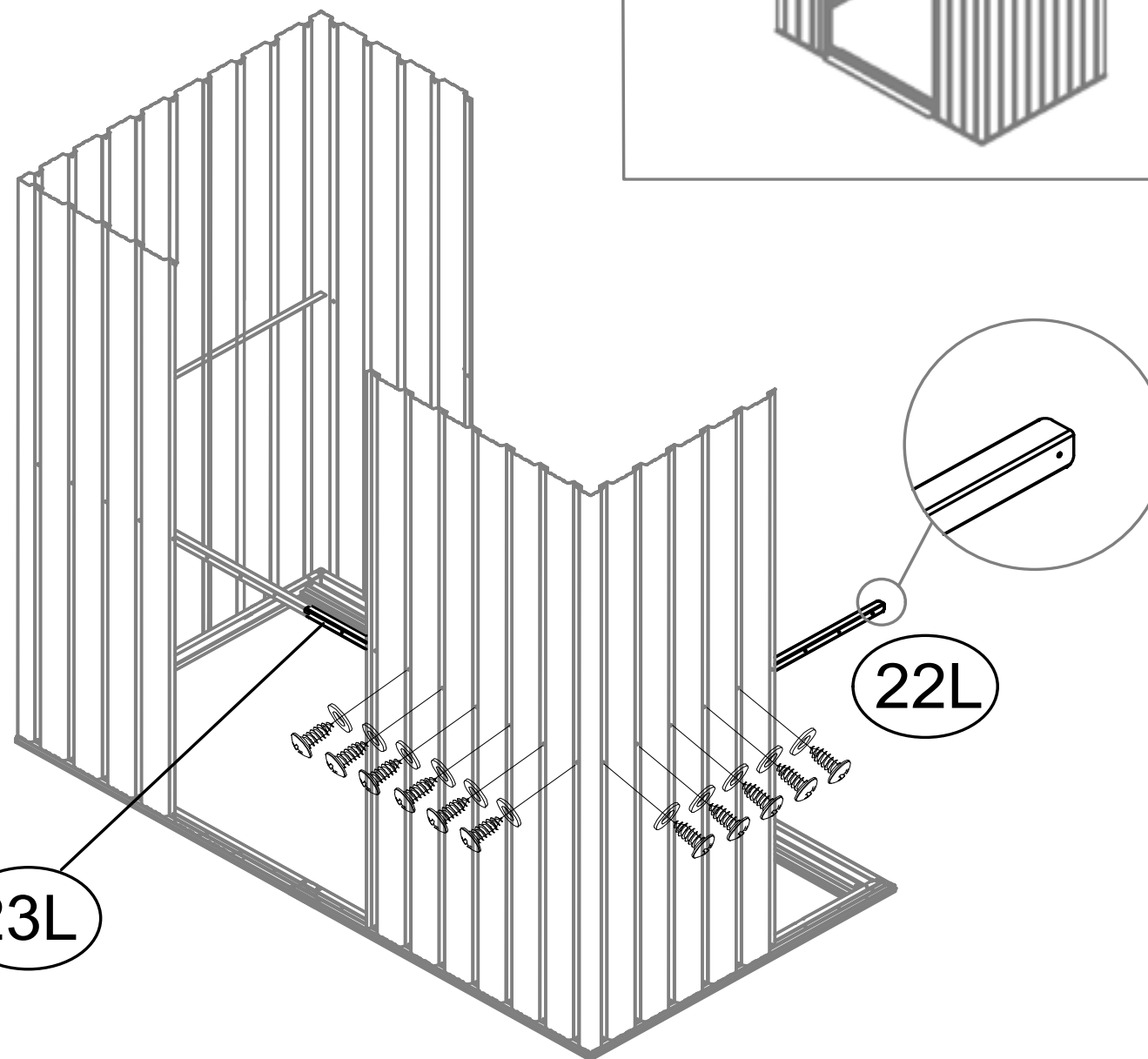

23L

22L

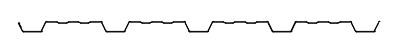

12

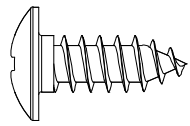
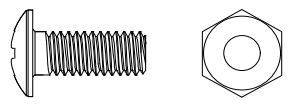
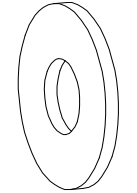
				
P1 (×1)	P9 (×1)	F1 (×12)	F2 (×1)	S3 (×13)

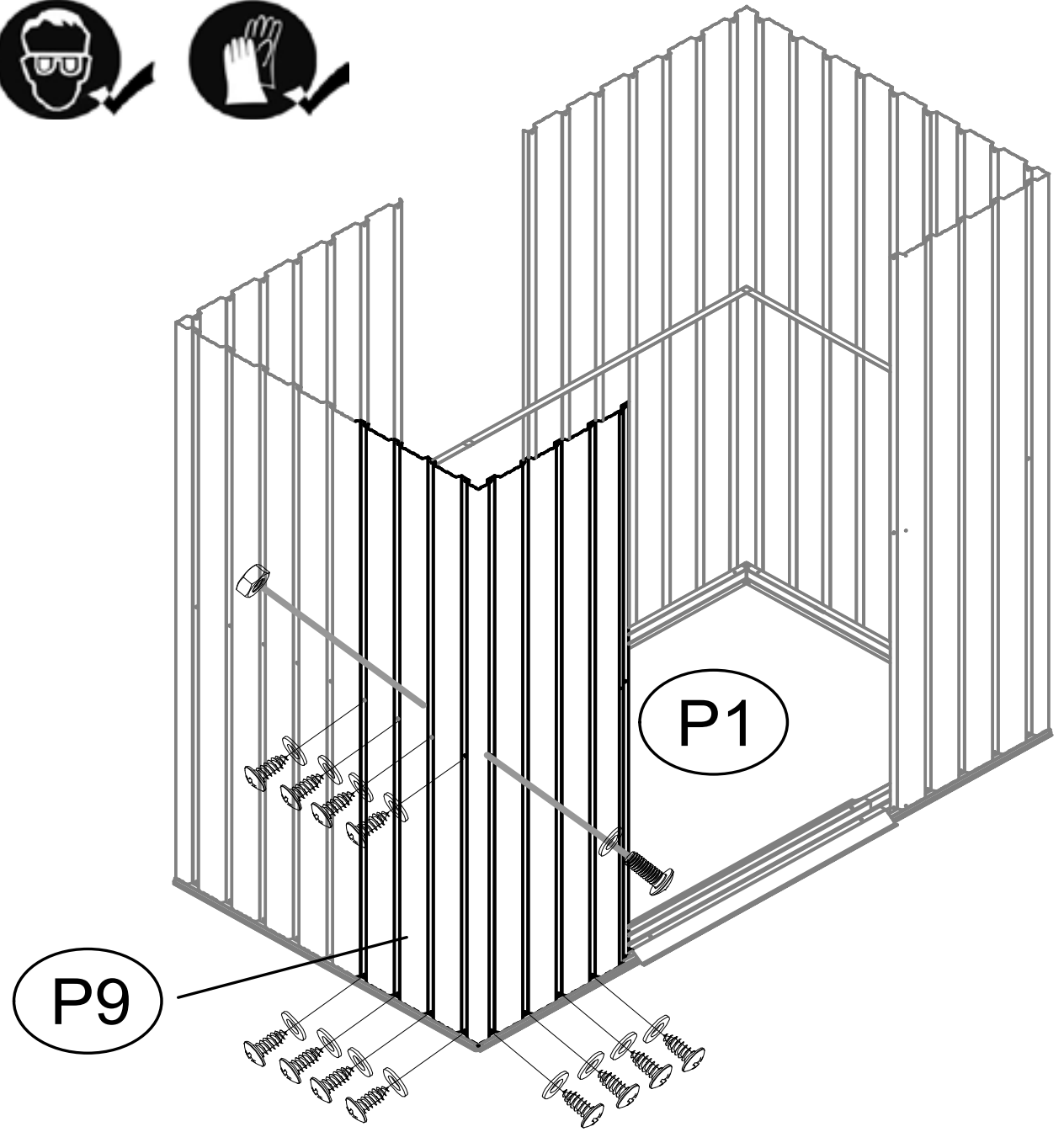
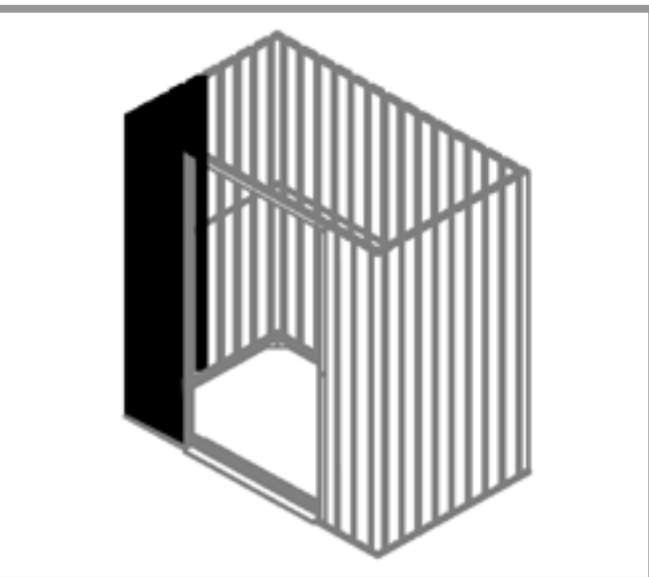

01

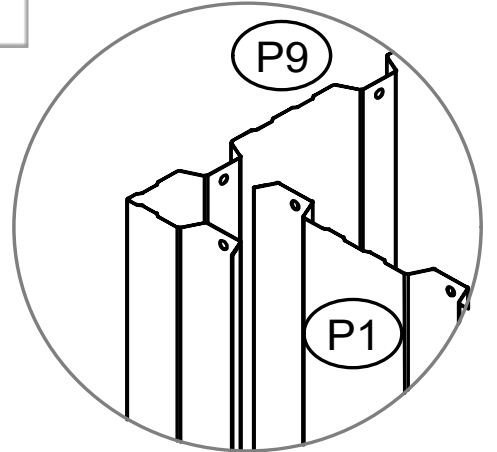

03

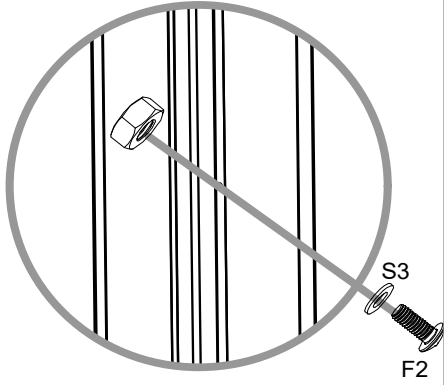

02

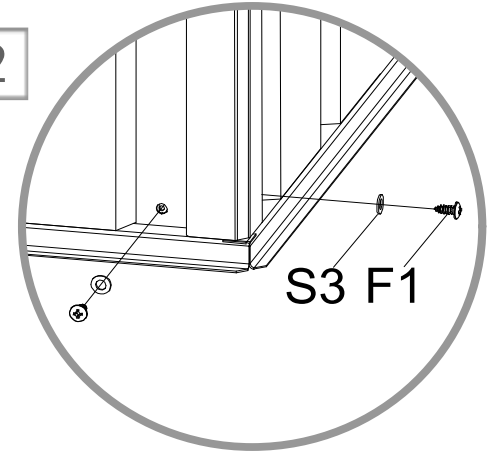

13

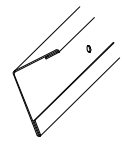

9 (×1)

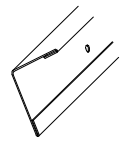

11 (×1)

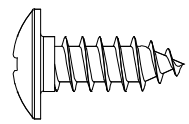

F1 (×18)

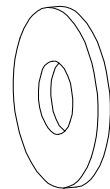

S3 (×18)

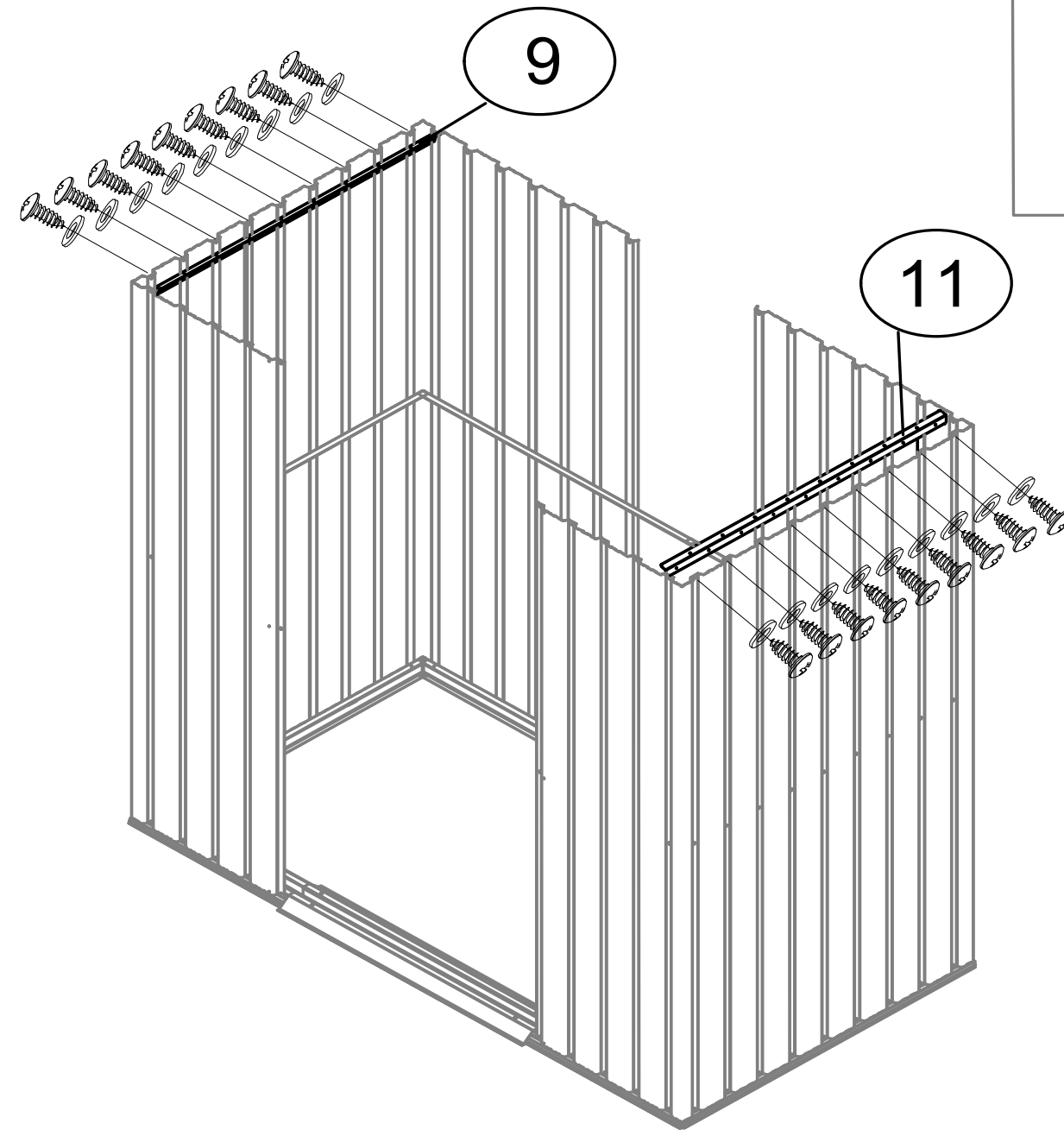

14

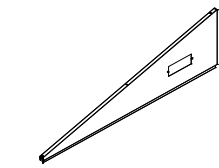

21L (×2)

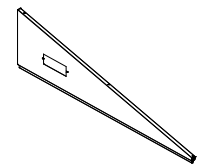

21R (×2)

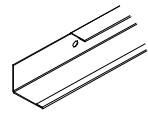

B3 (×2)

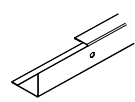

B4 (×2)



12 (×2)



F2 (×4)

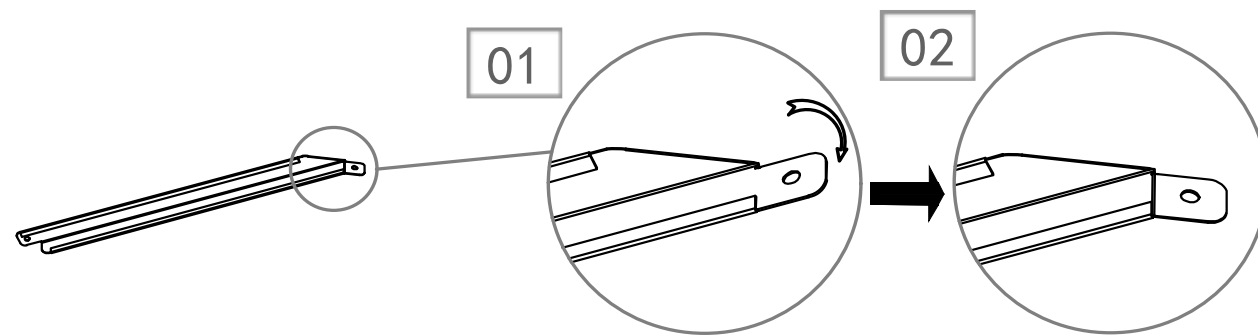
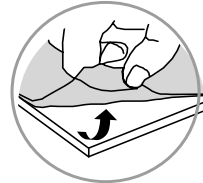
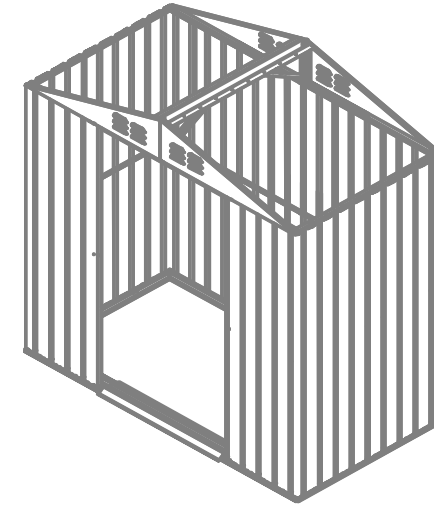

Bent an angle of Part 12 to fit the screw hole of beam

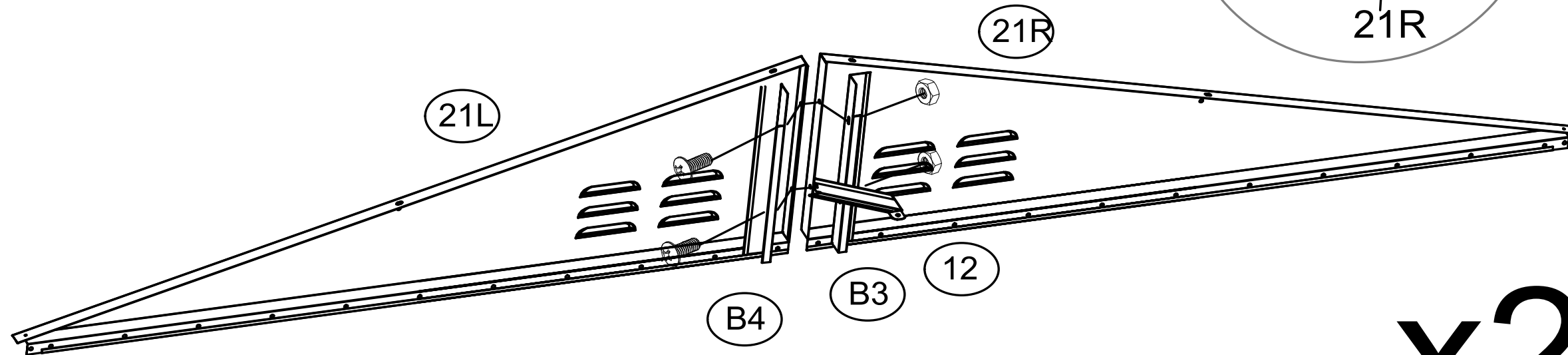
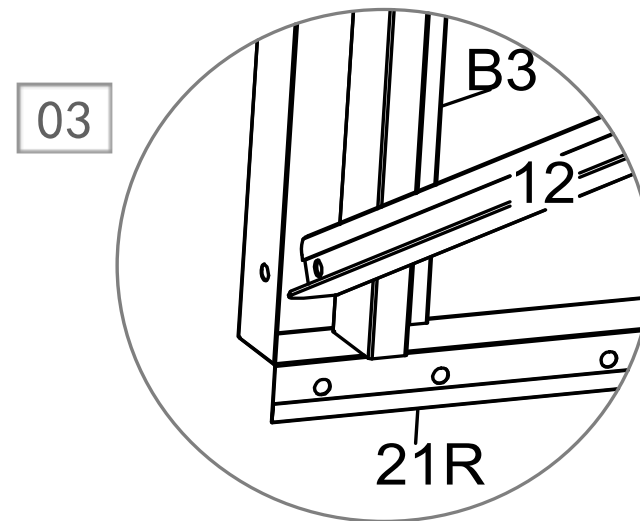

x2

15



10L (×1)

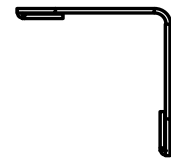

10R (×1)

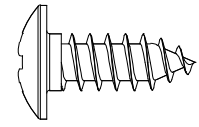

F1 (×10)

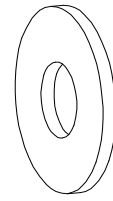

S3 (×10)

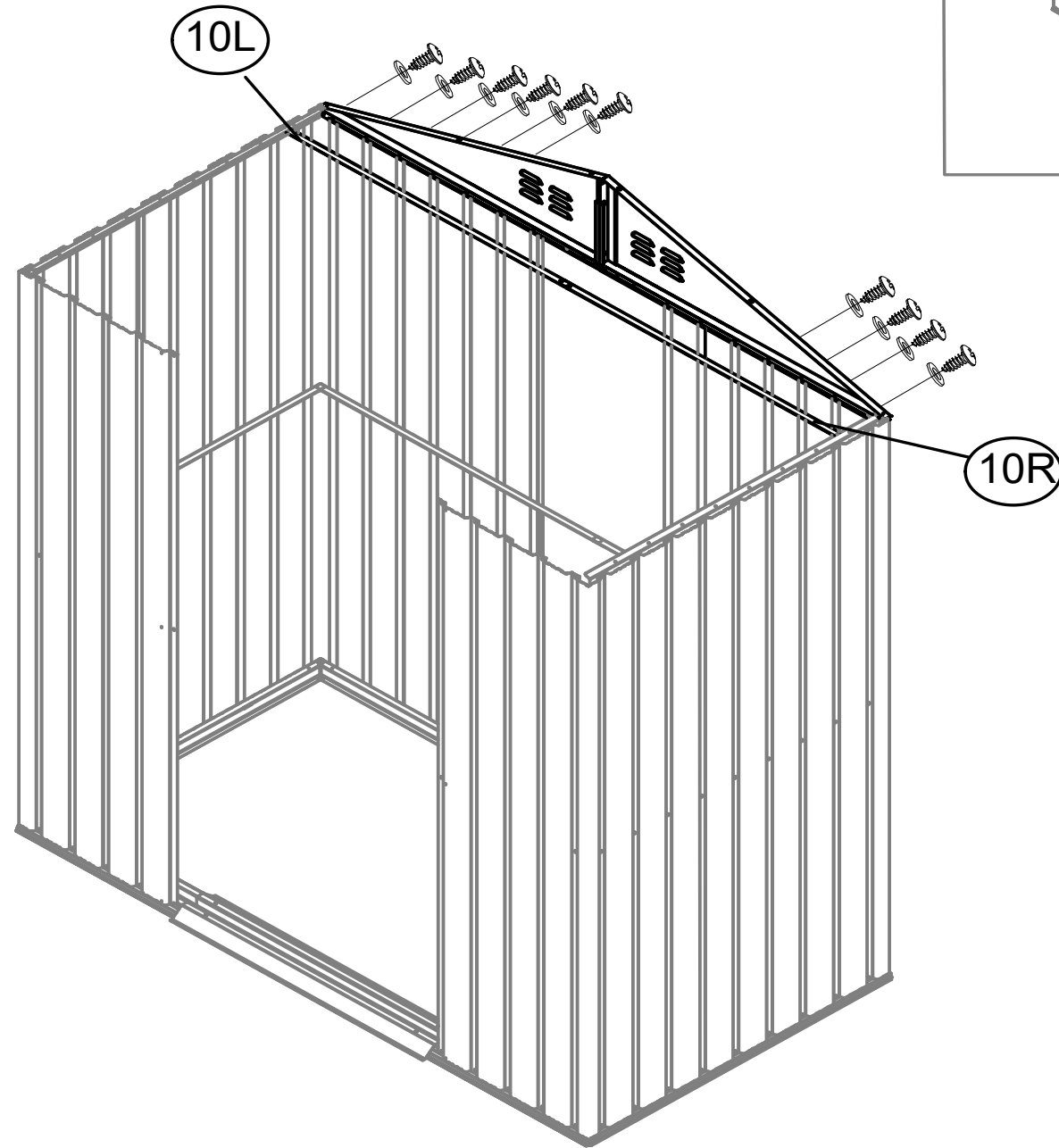
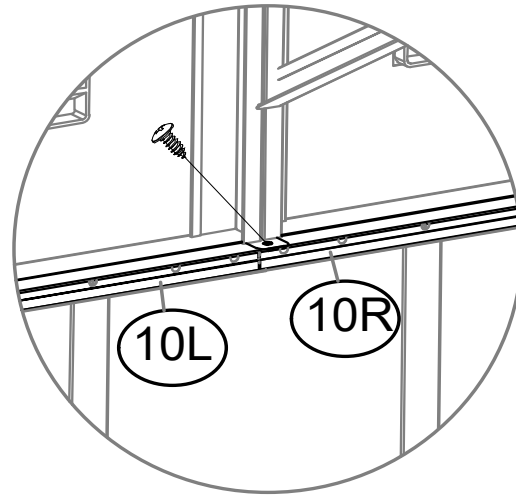
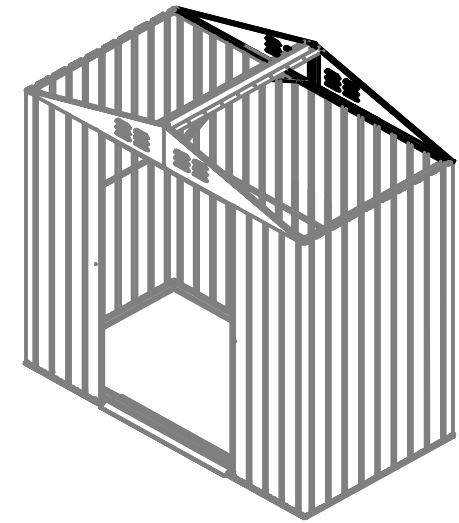

16



7 (×1)



8 (×1)

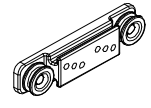

G2 (×4)

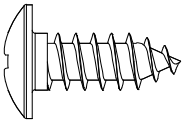

F1 (×8)

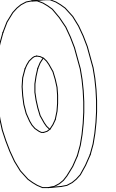

S3 (×8)

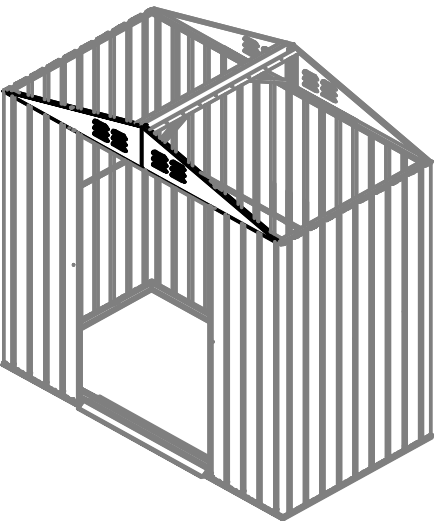

01

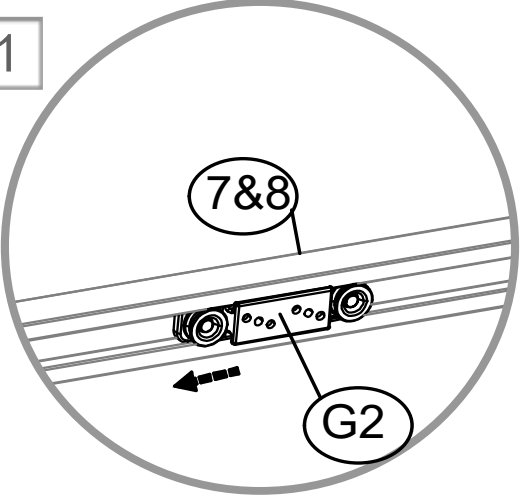

02

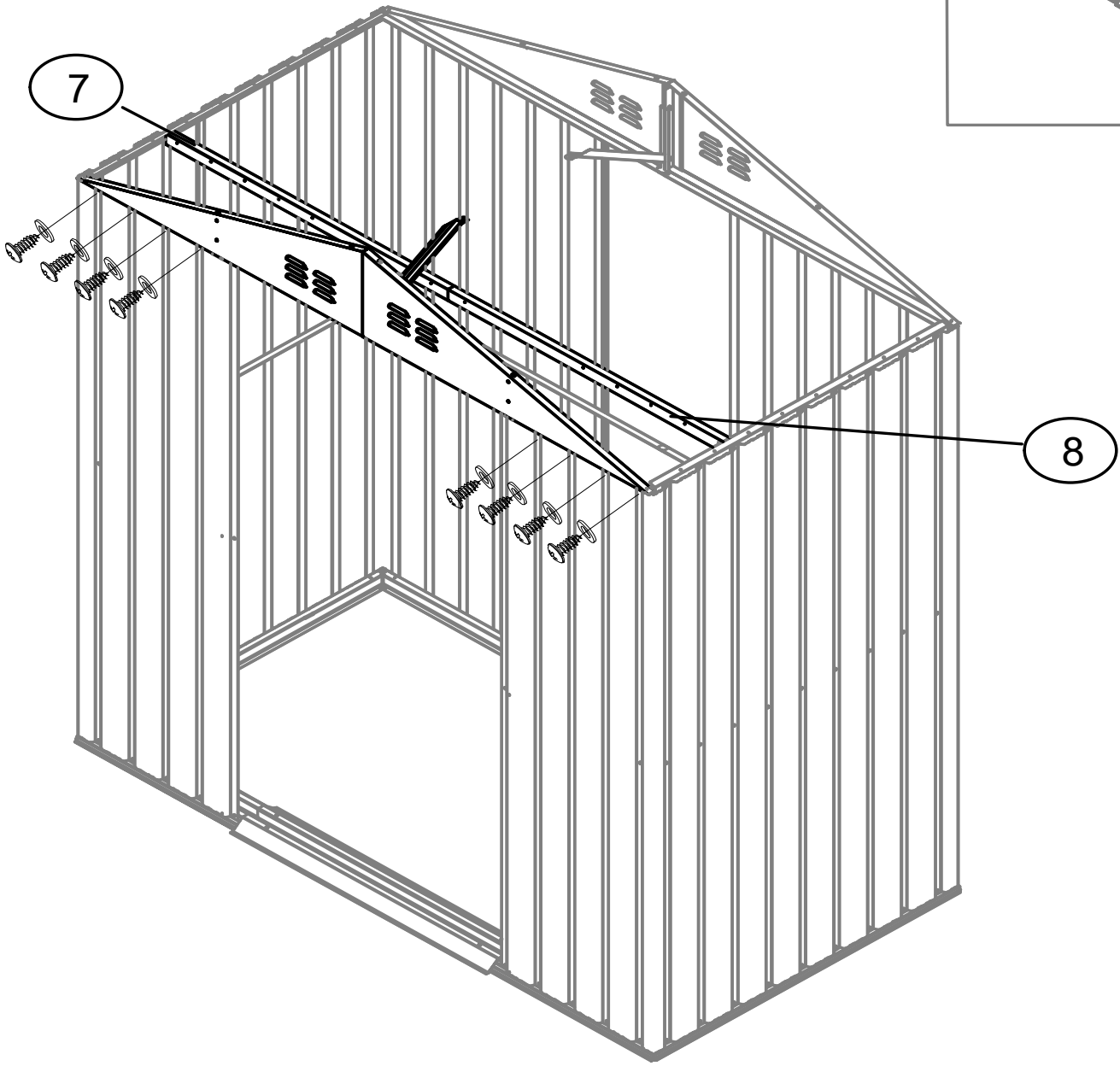
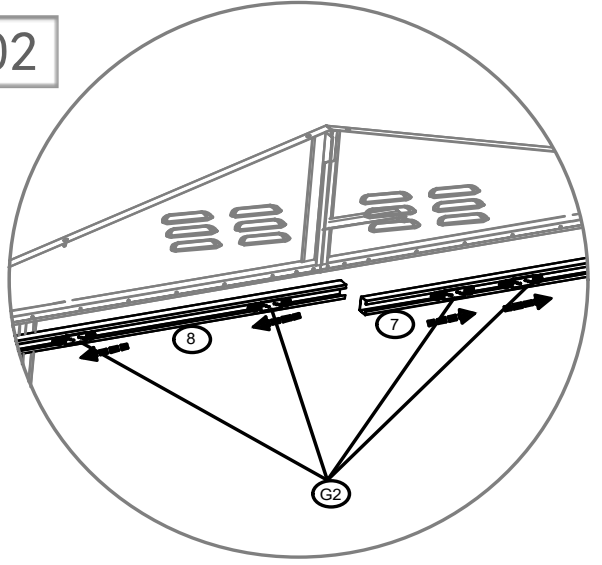

17

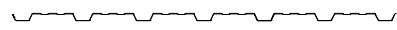

P3 (×1)

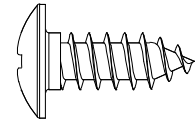

F1 (×21)

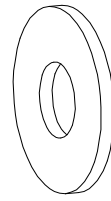

S3 (×21)

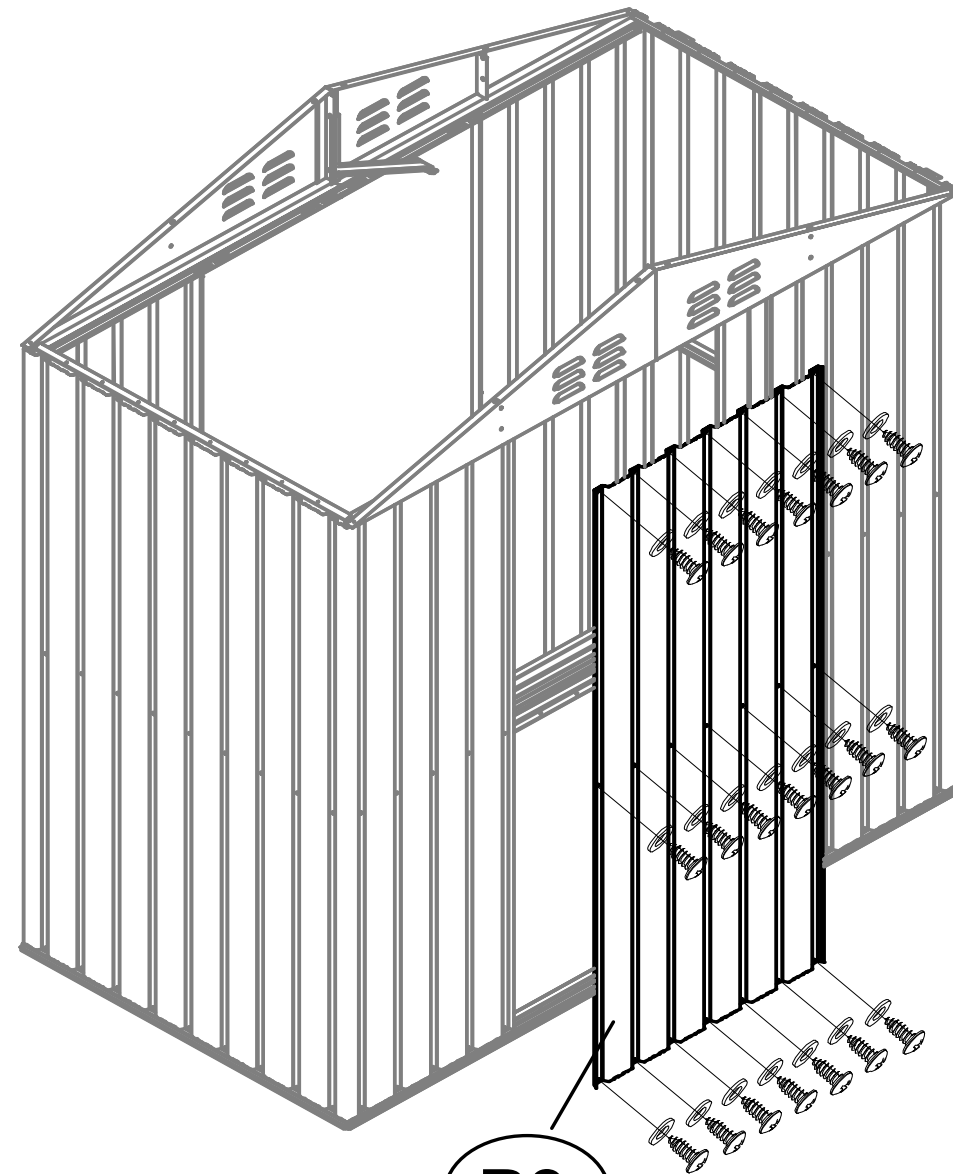
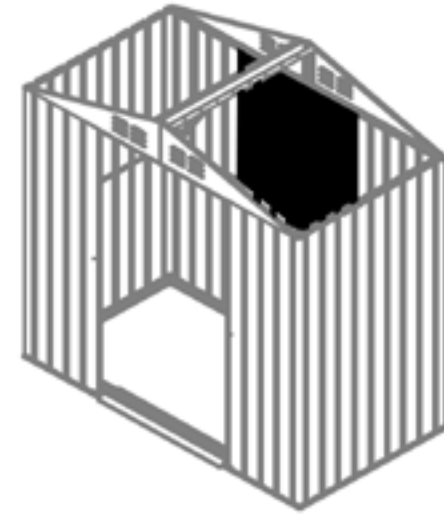

P3

18

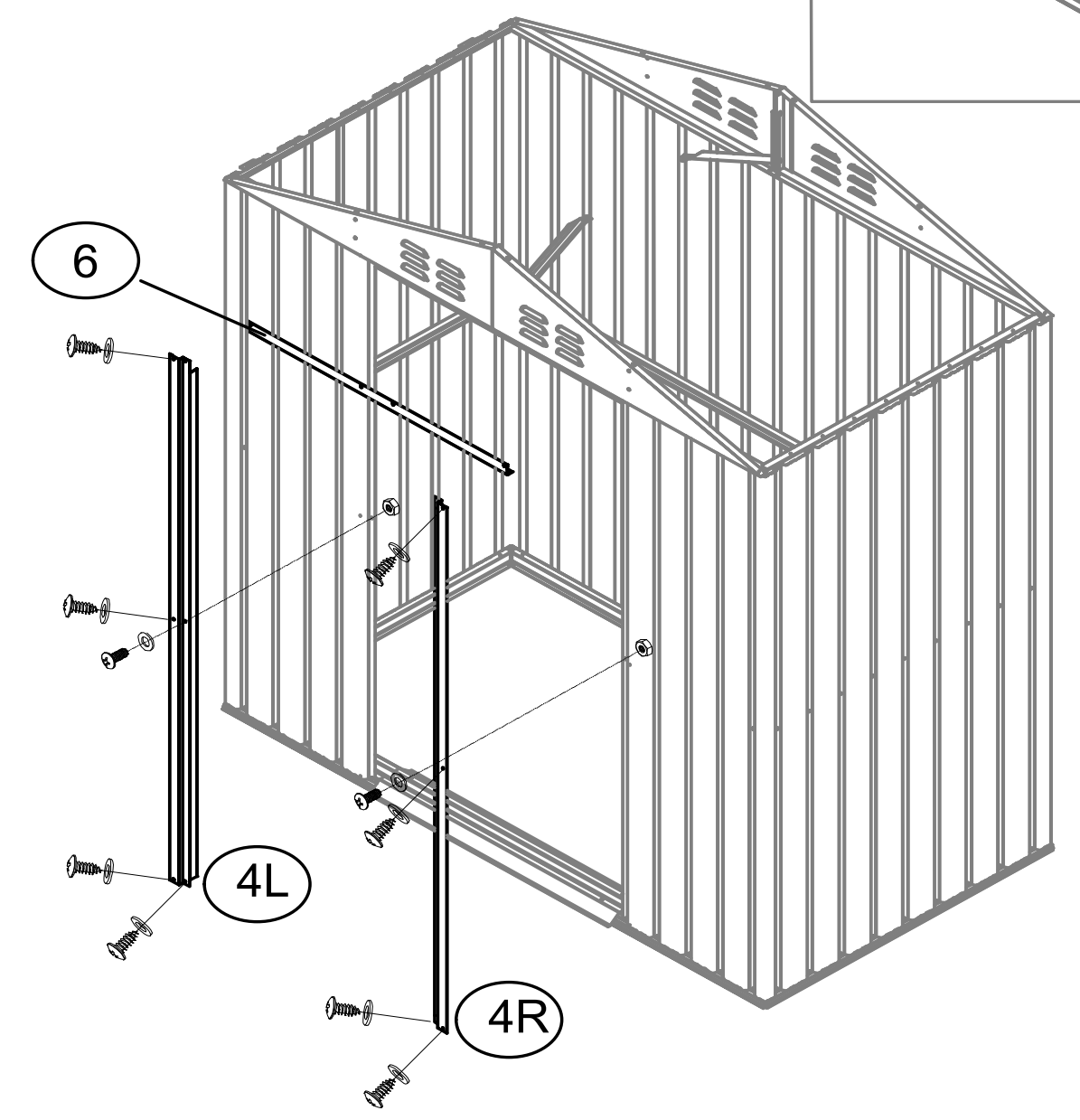
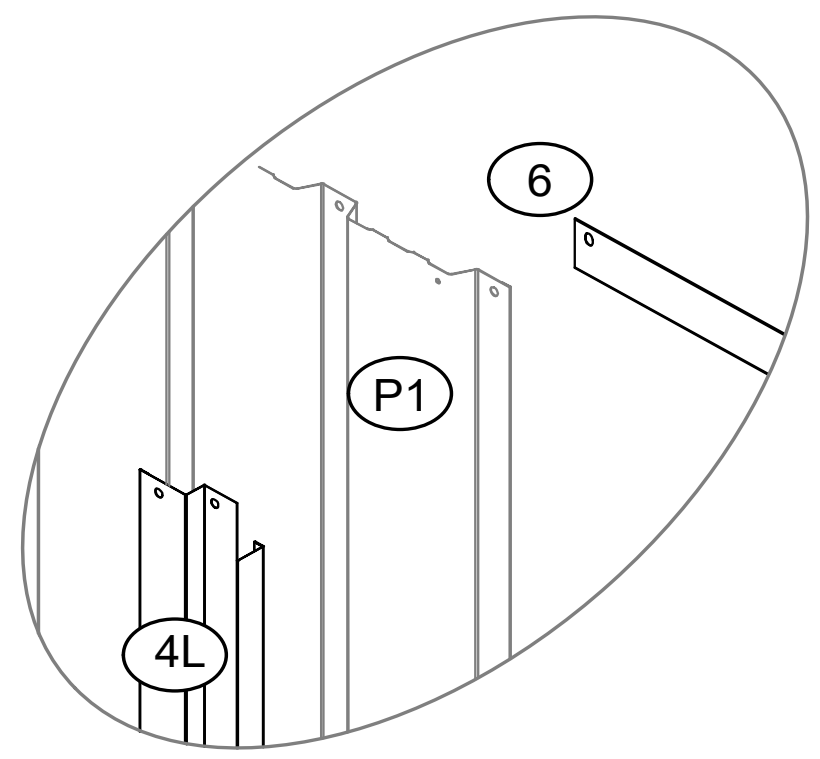
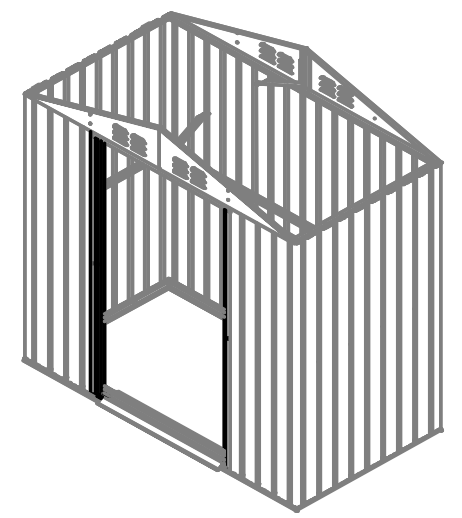
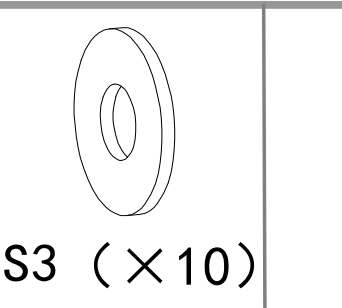
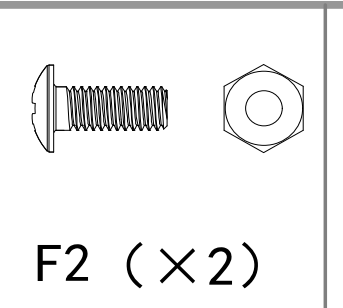
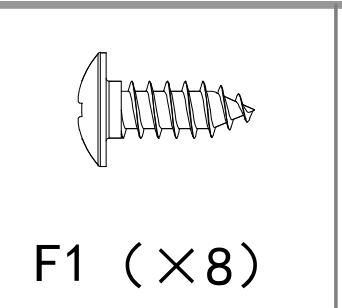
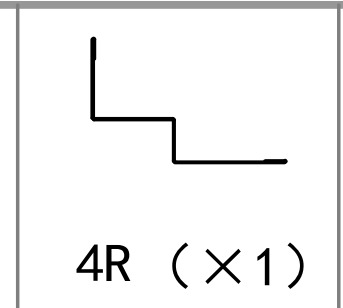
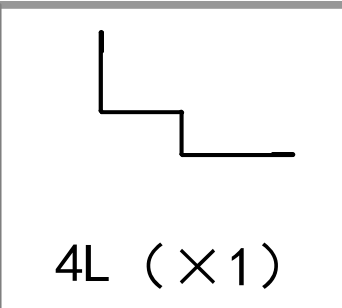
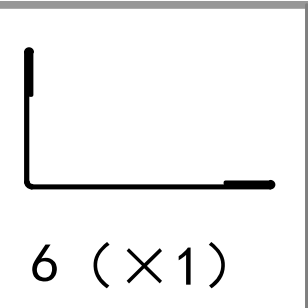

19

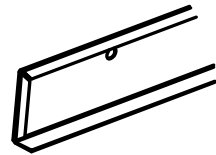

6-1 (×1)

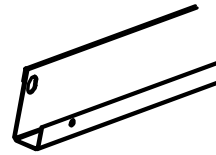

6-2 (×1)

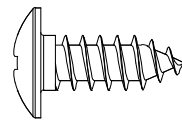

F1 (×6)

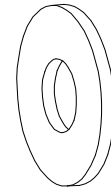

S3 (×6)

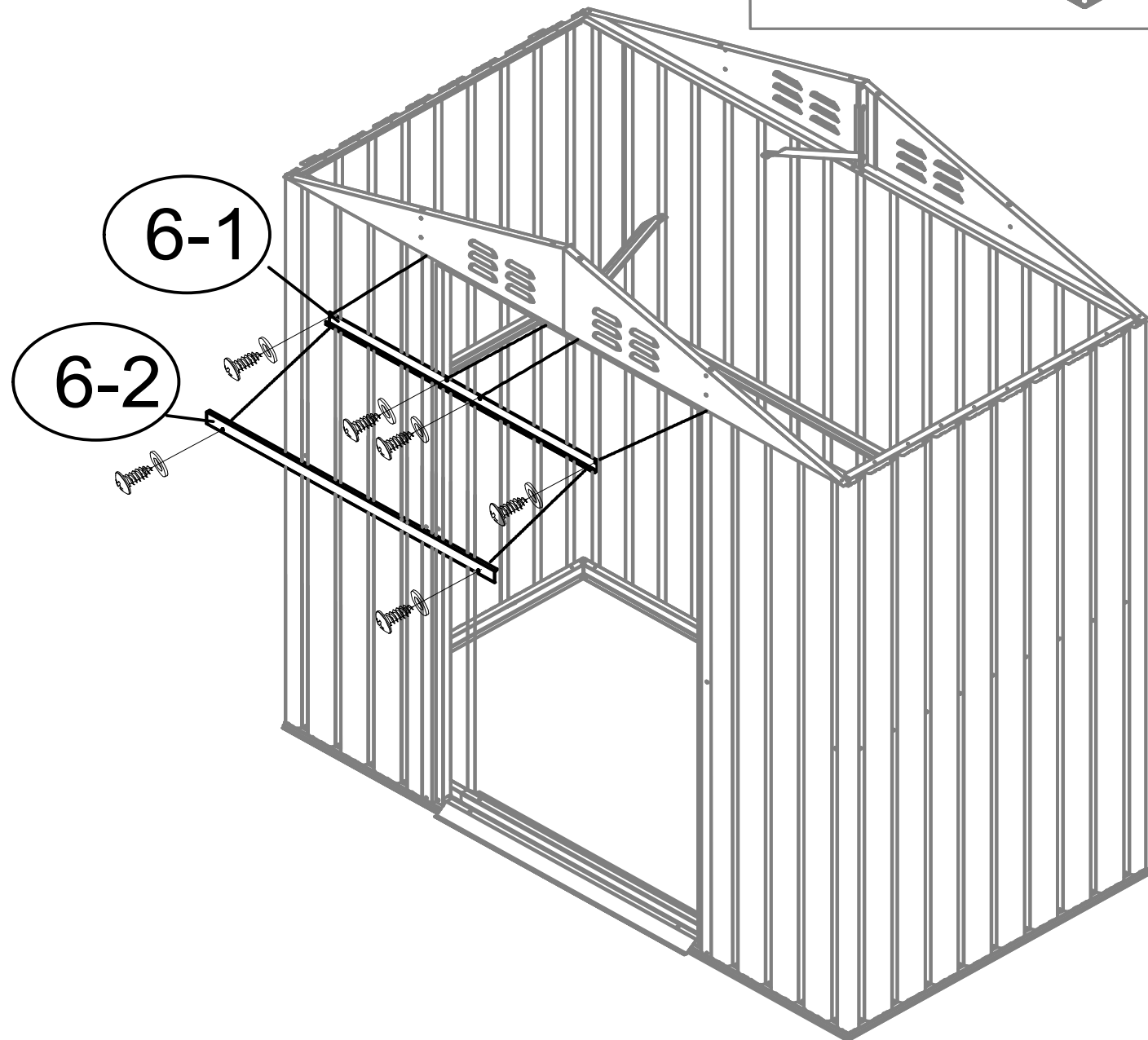
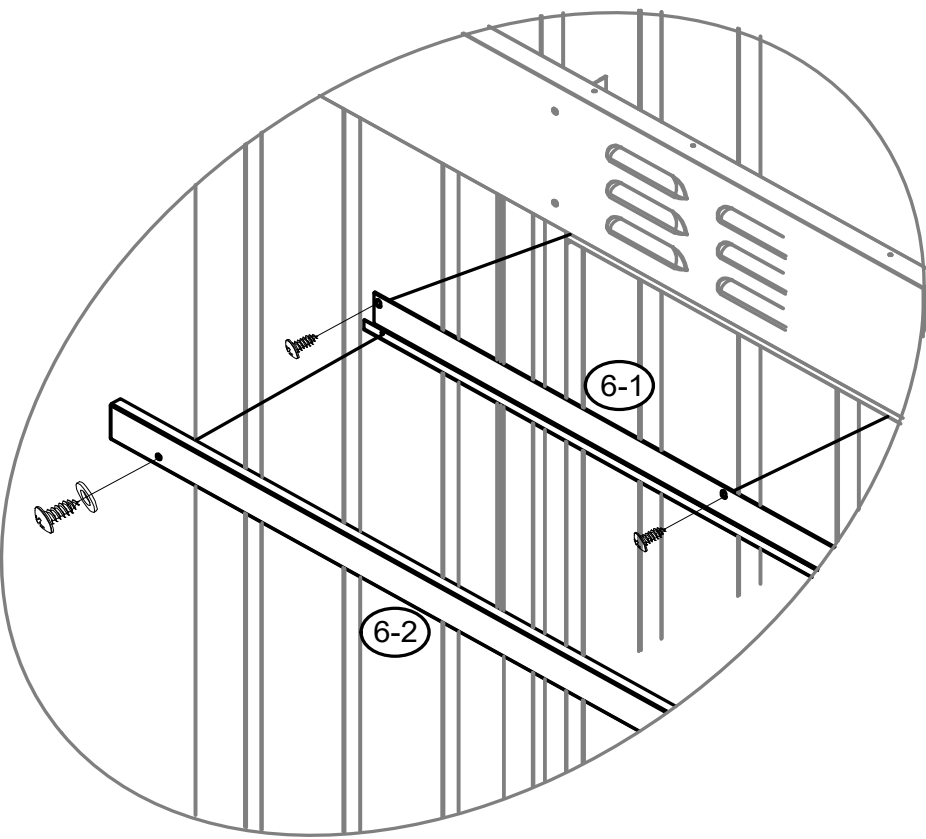
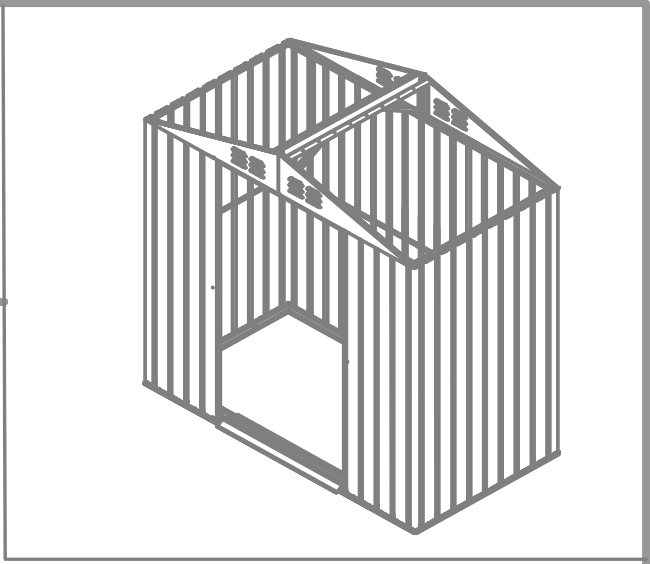

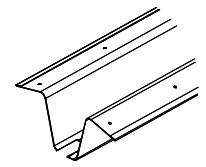

16 (×1)



F2 (×2)

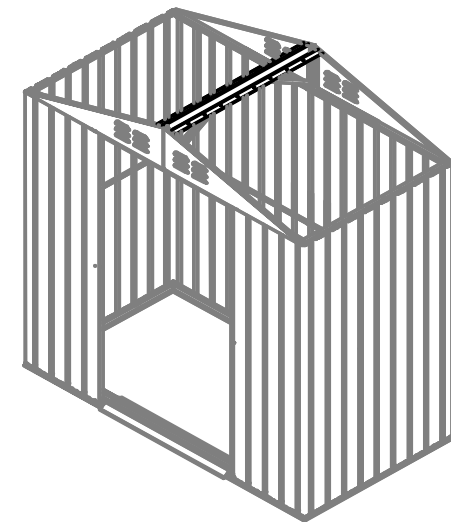

16

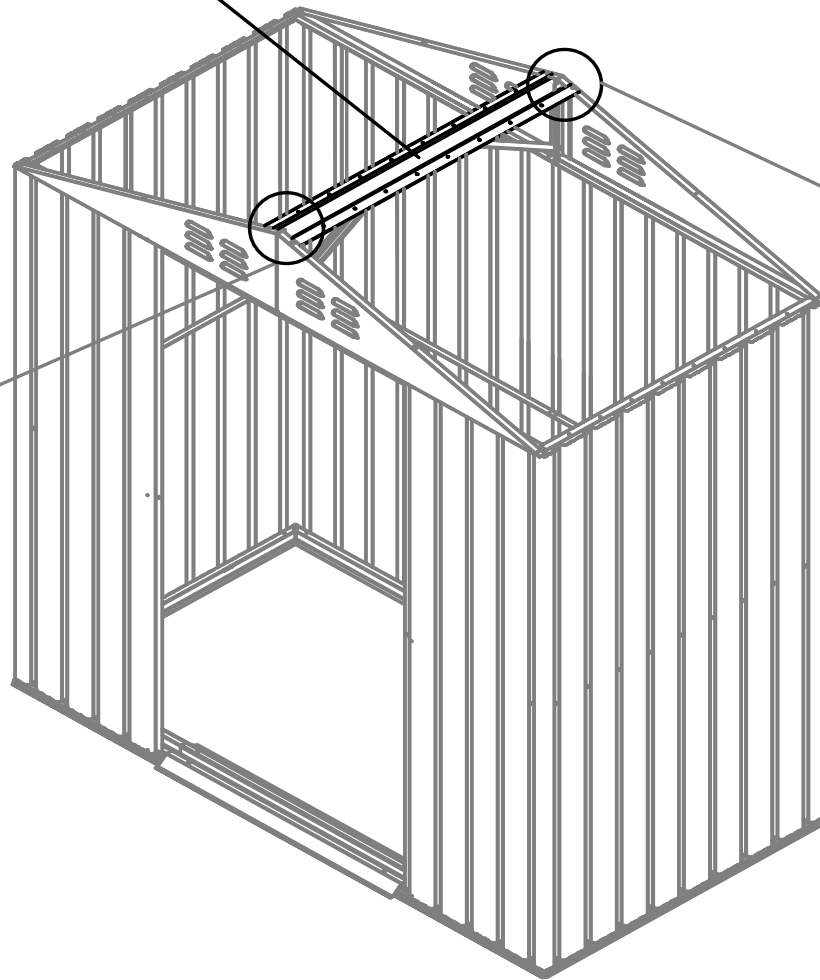

01

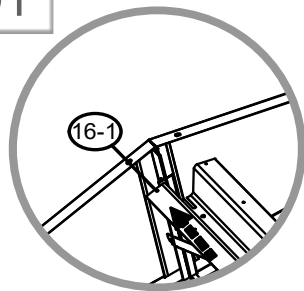

02

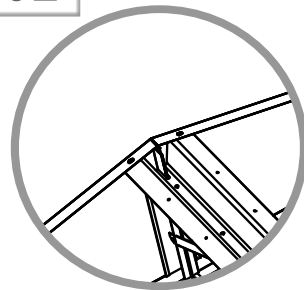

03

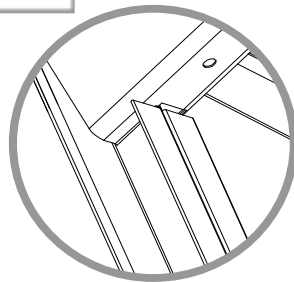

04

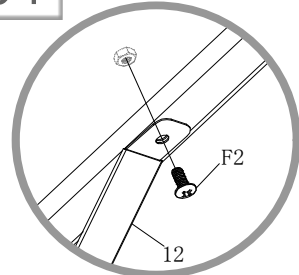

01

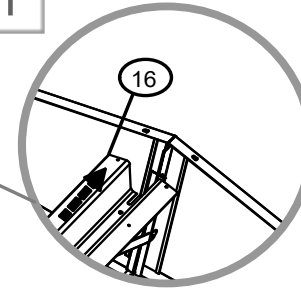

02

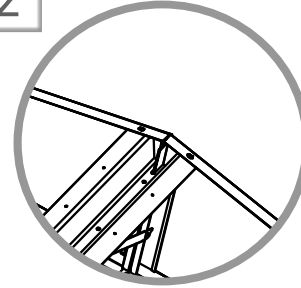

03

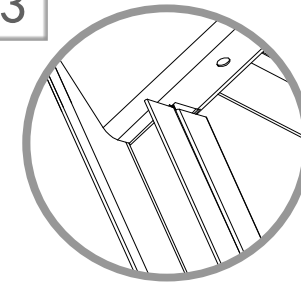

04

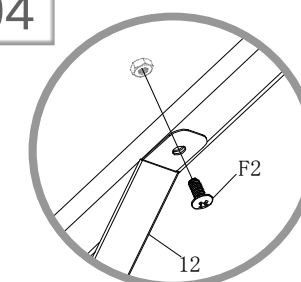

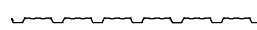
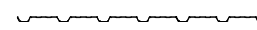
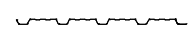
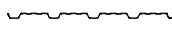
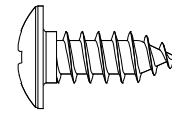
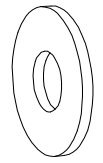
					
P5 (×1)	P6 (×1)	P10 (×1)	P11 (×1)	F1 (×32)	S3 (×32)

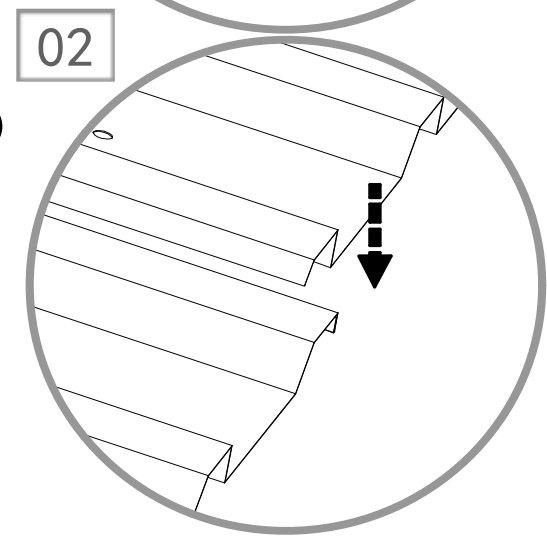
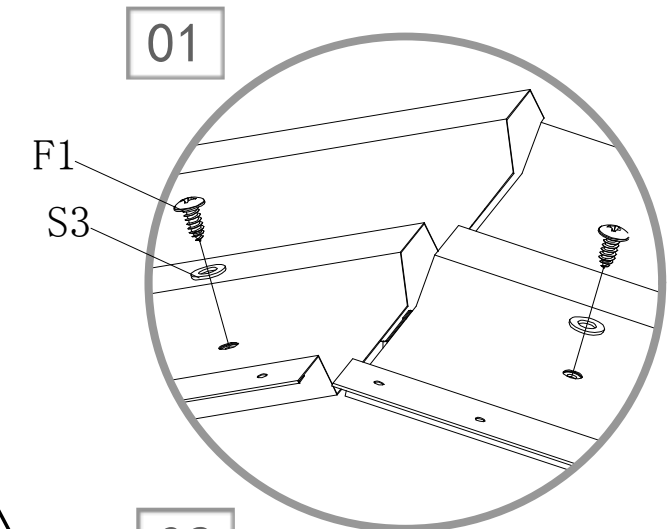
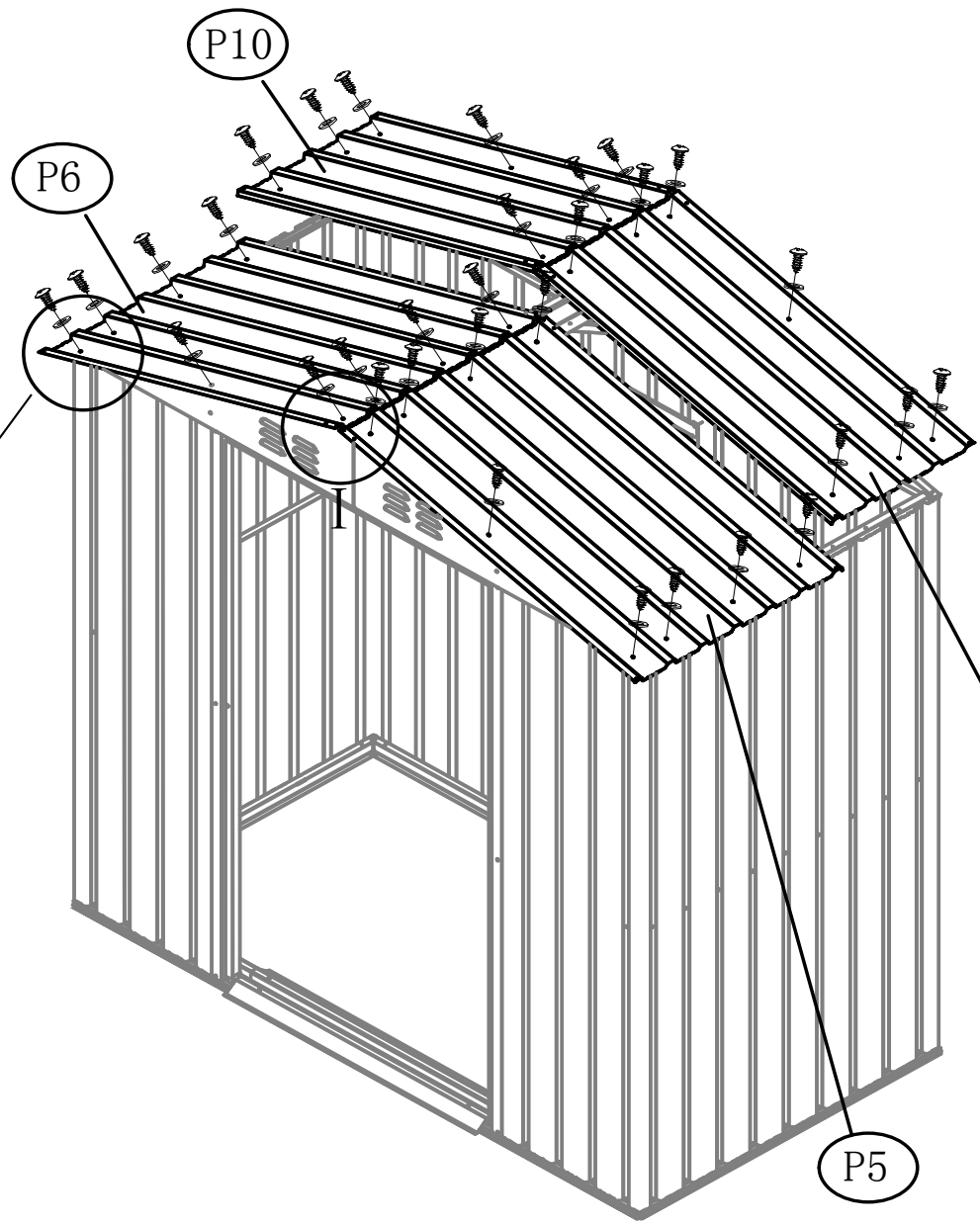
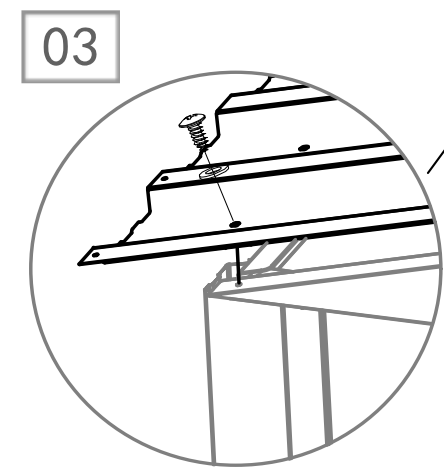
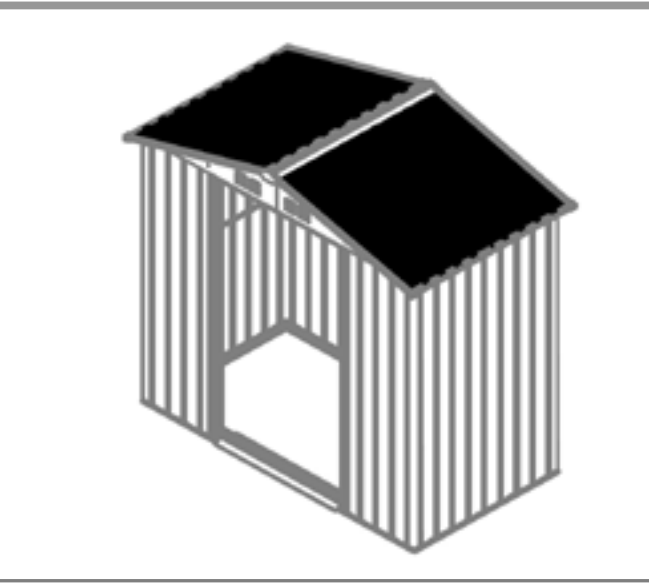

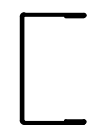
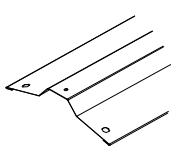
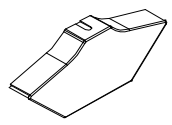
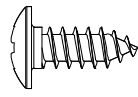
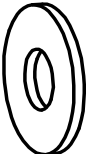
				
17L (×4)	19 (×1)	GE (×2)	F1 (×8)	S3 (×2)

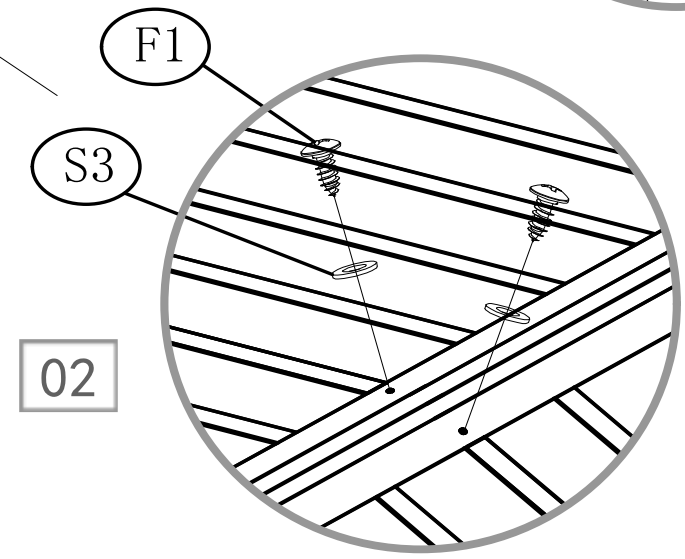
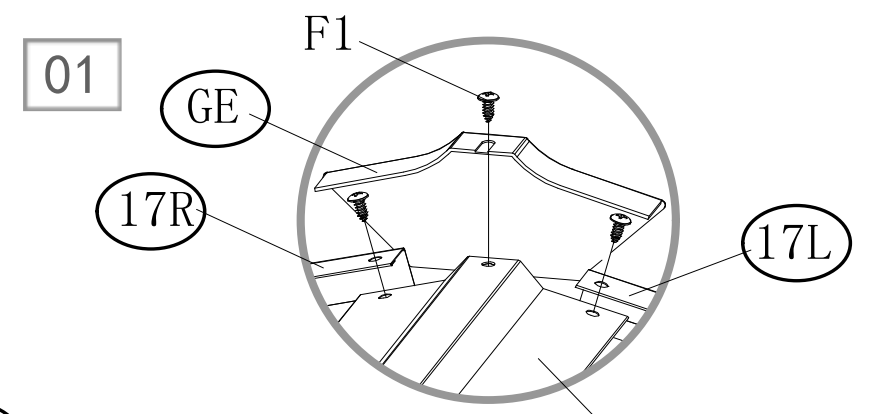
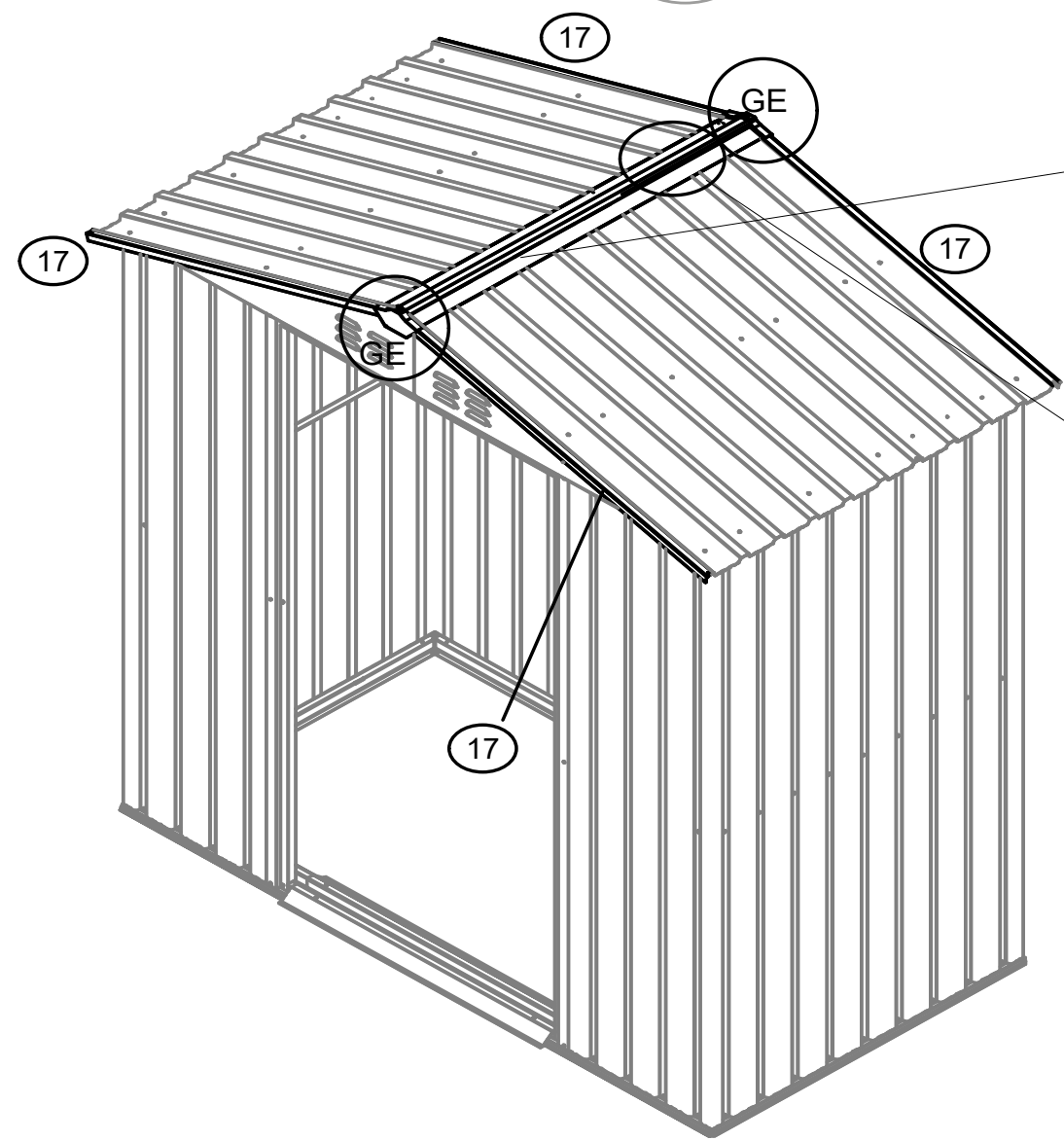

23

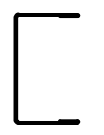
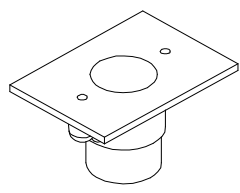
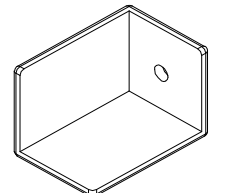
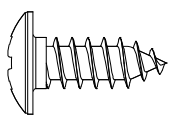
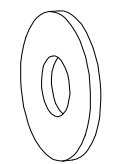
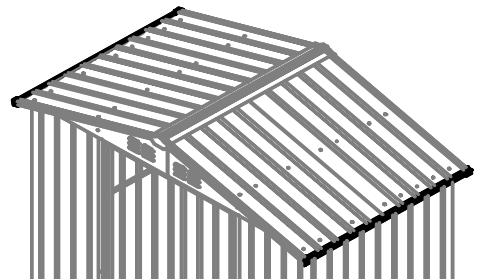
					
15 (×2)	GS (×4)	GC (×4)	F1 (×12)	S3 (×4)	

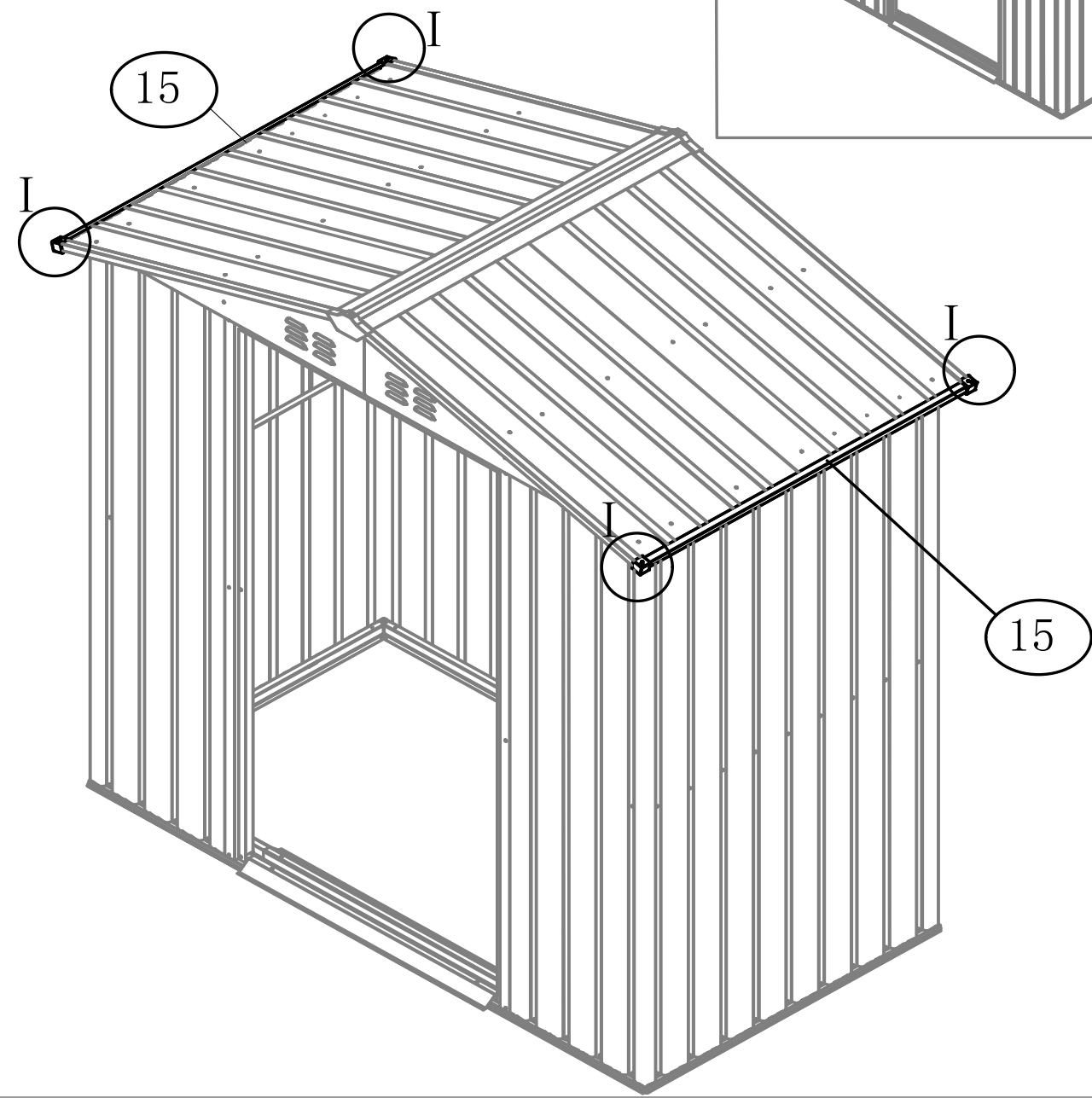
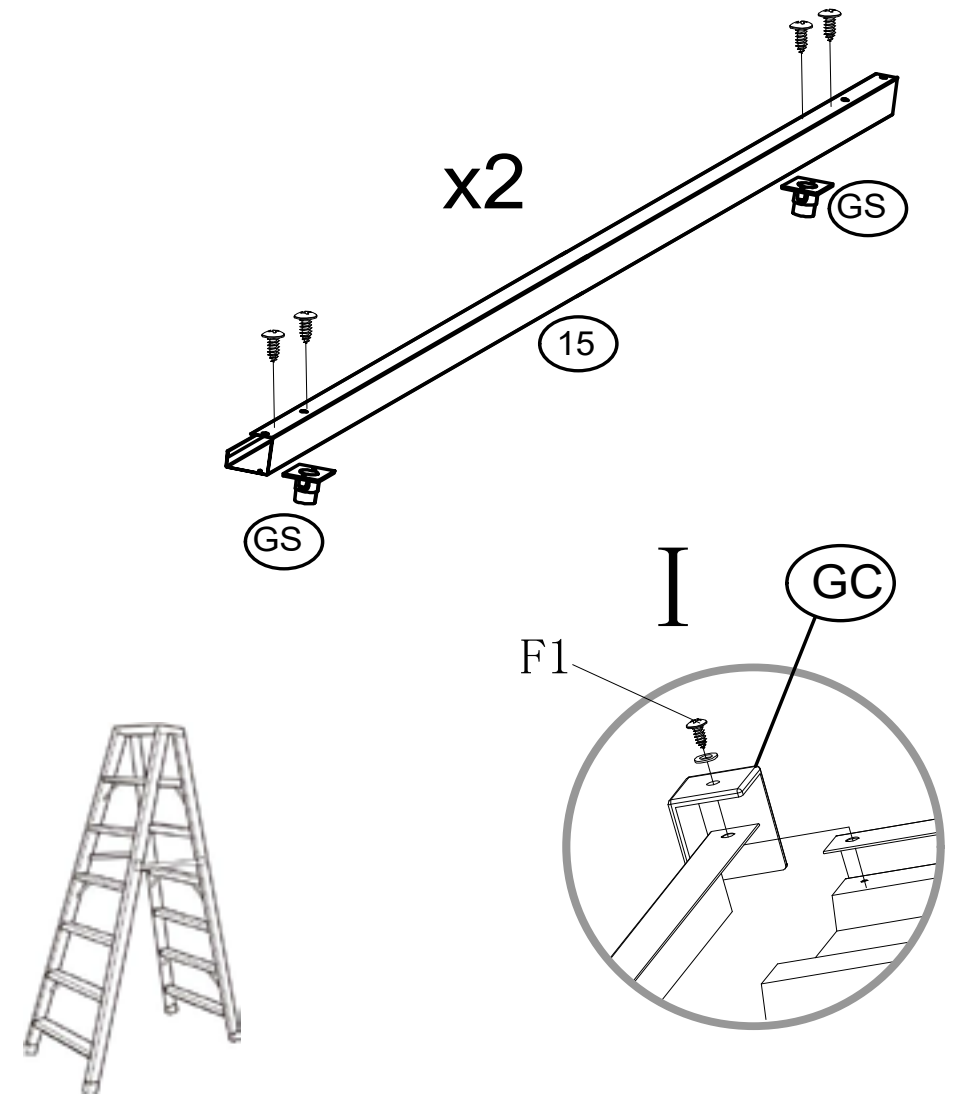



D1 (×1)



D2 (×1)

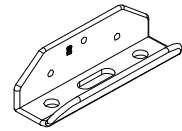

GB (×2)

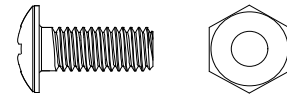

F2 (×2)

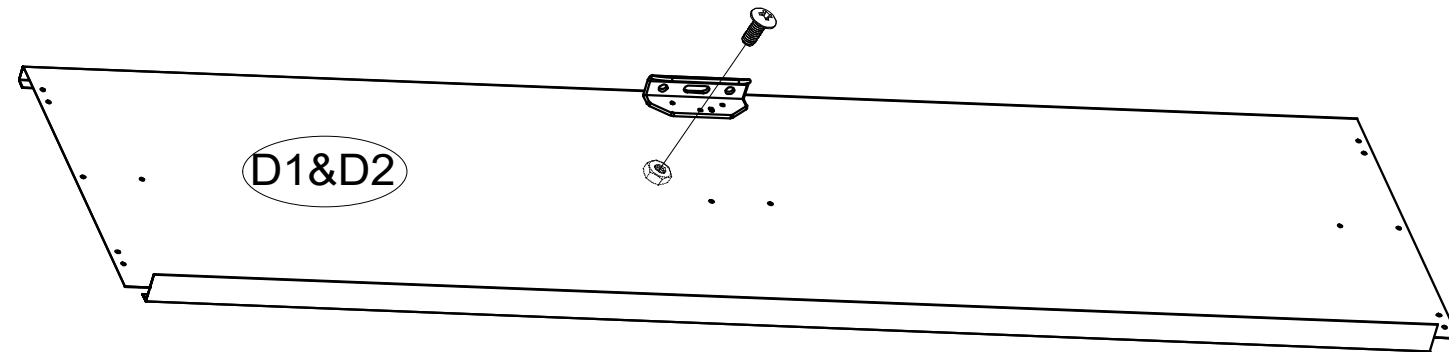
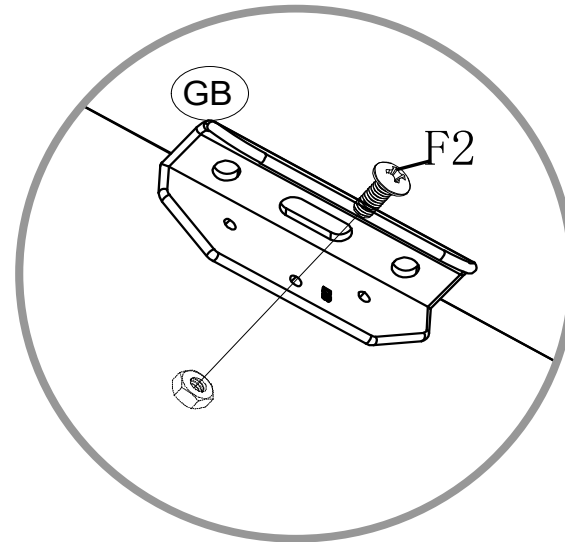
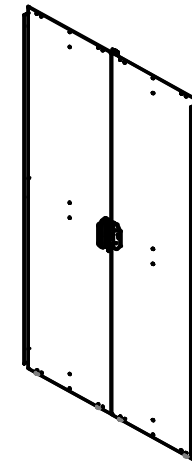

x2

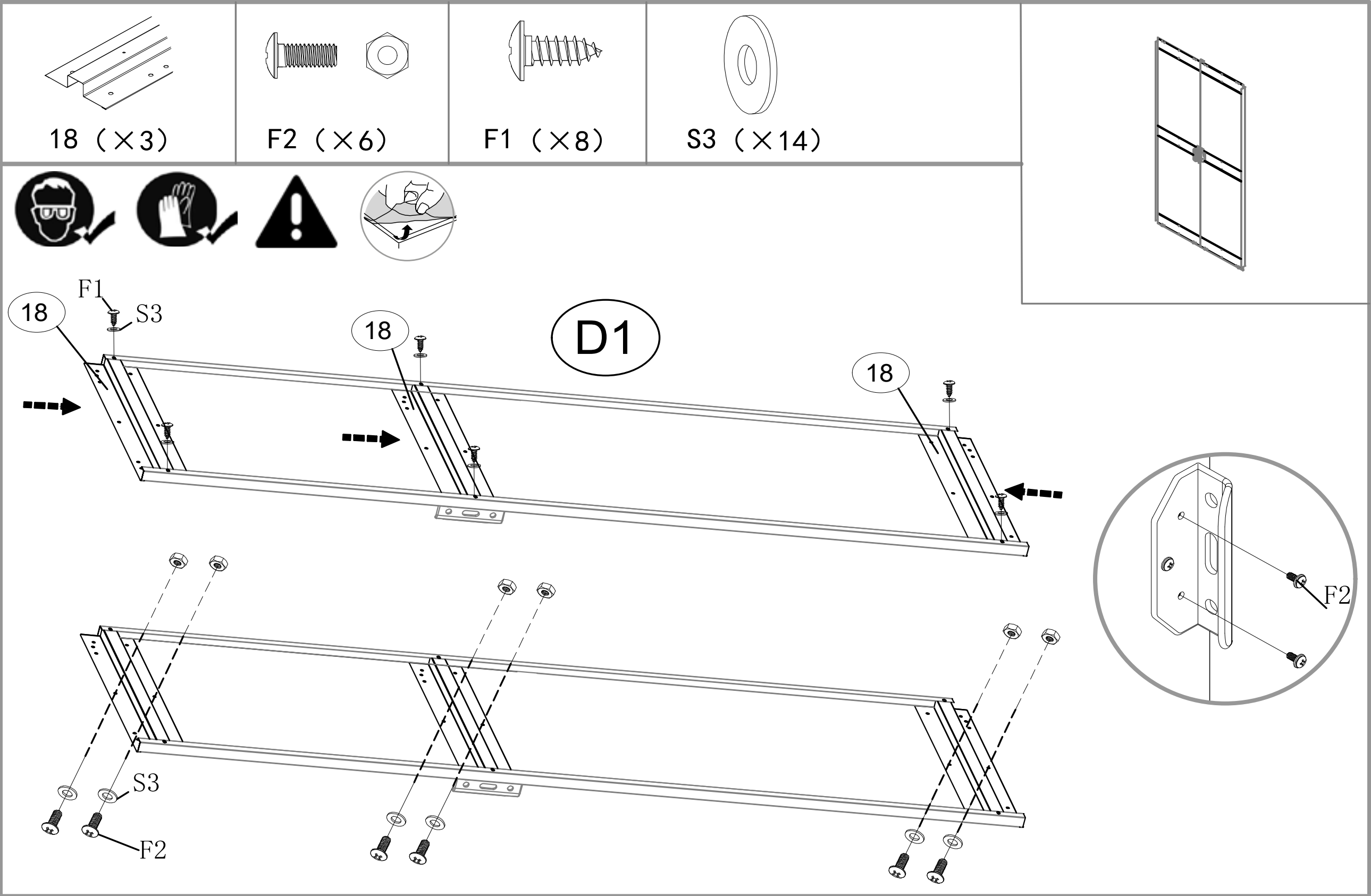

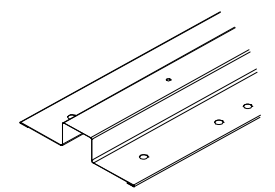

18 (×3)

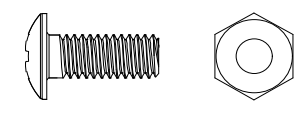

F2 (×6)

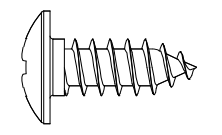

F1 (×8)

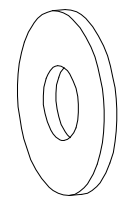

S3 (×14)

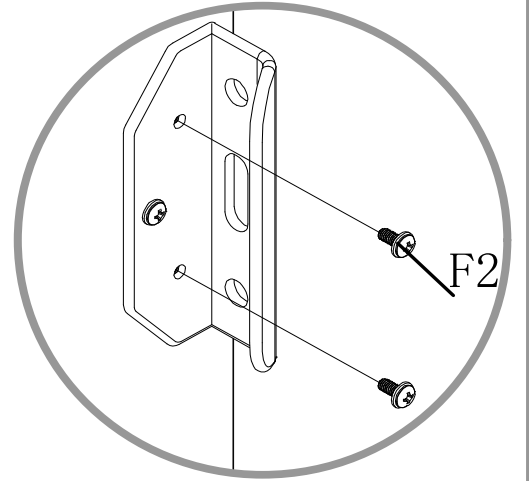
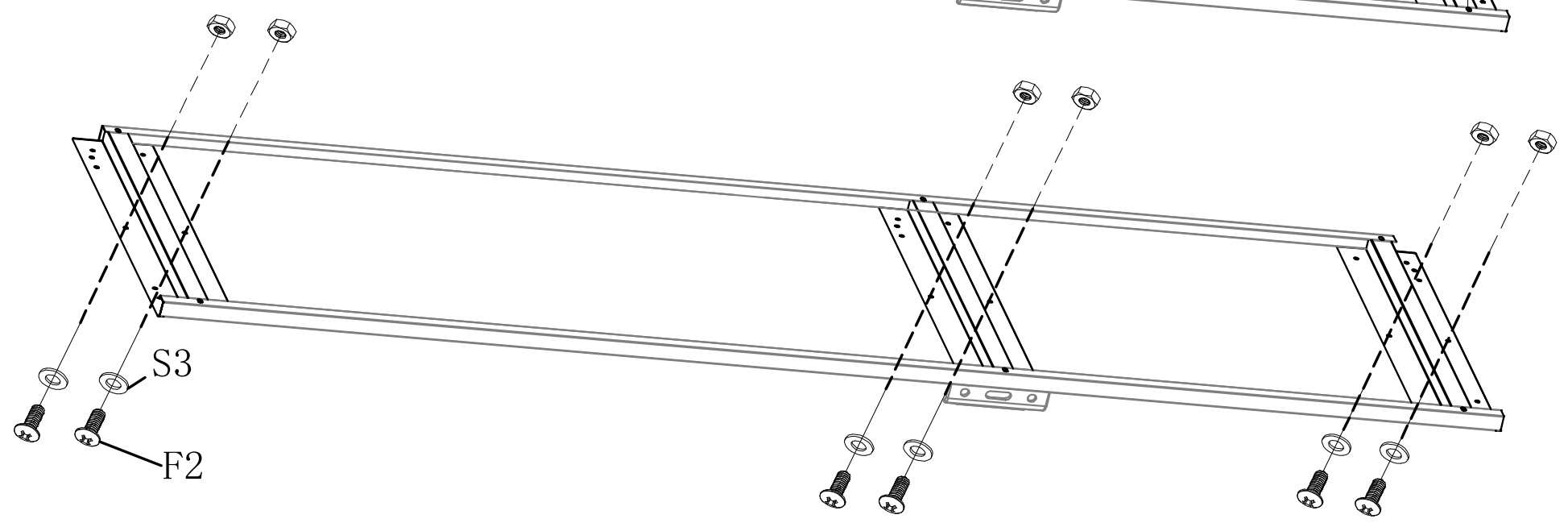
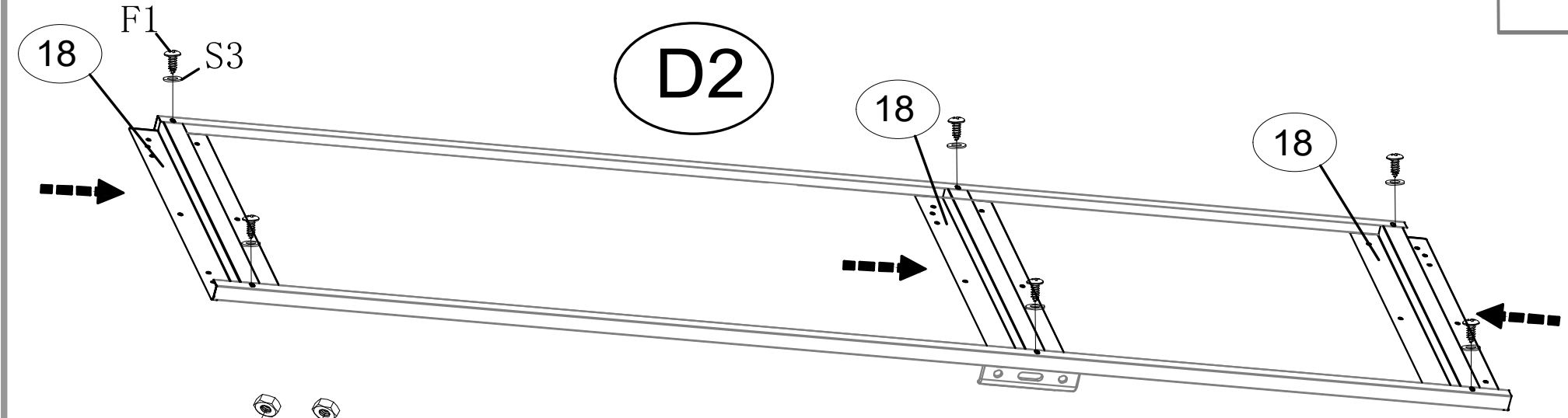
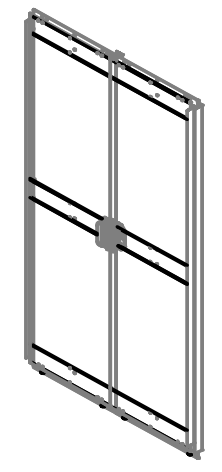

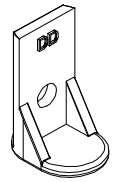

GD (×4)

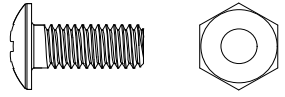

F2 (×4)

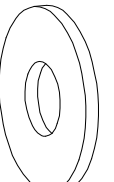

S3 (×4)

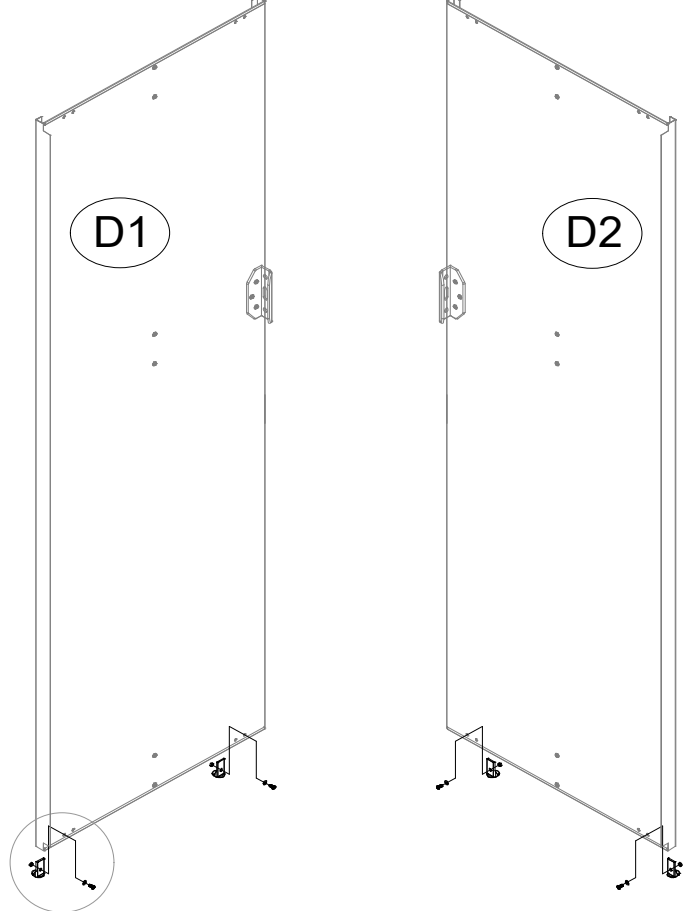
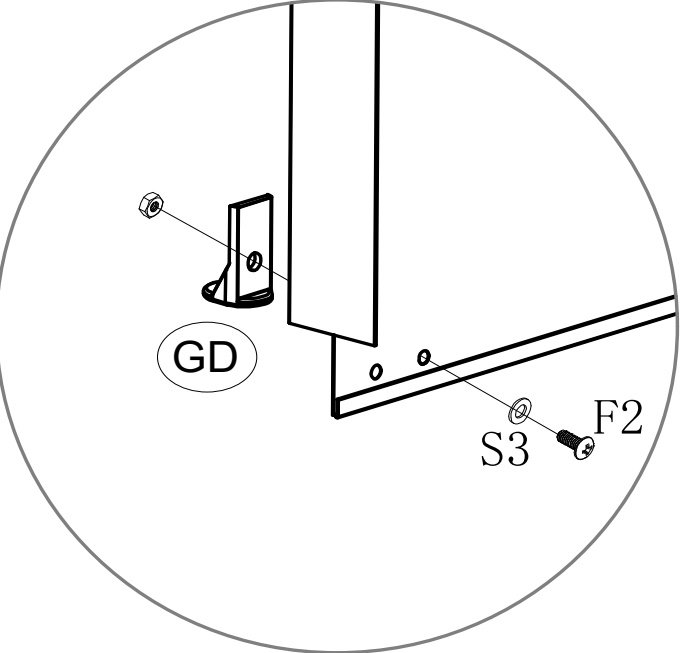
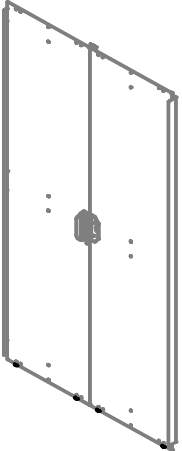

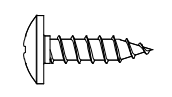

F3 (X8)



7&8

G2

01

02

F3

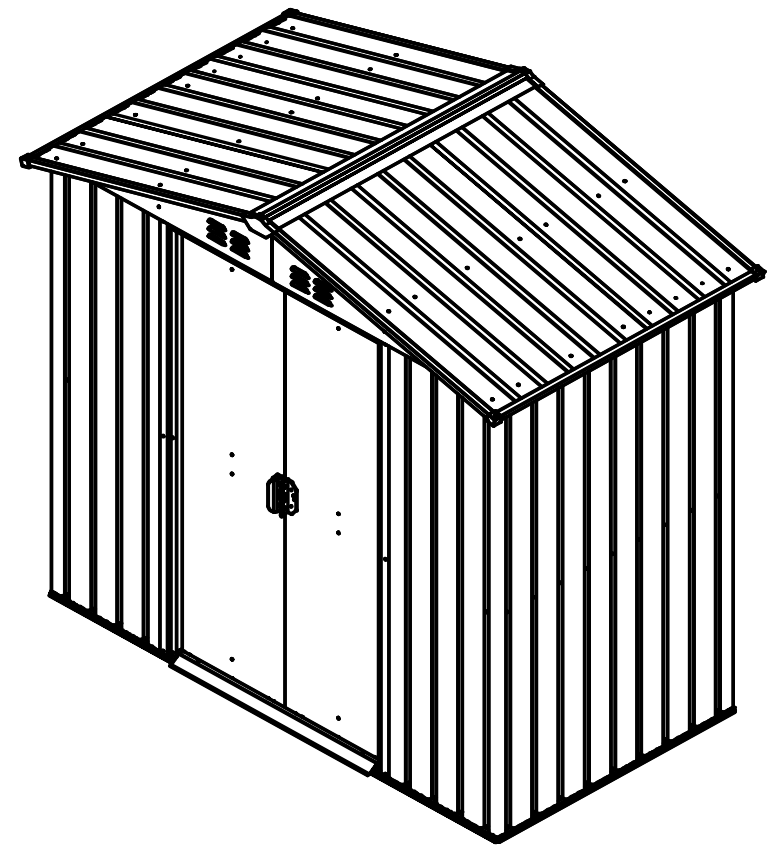
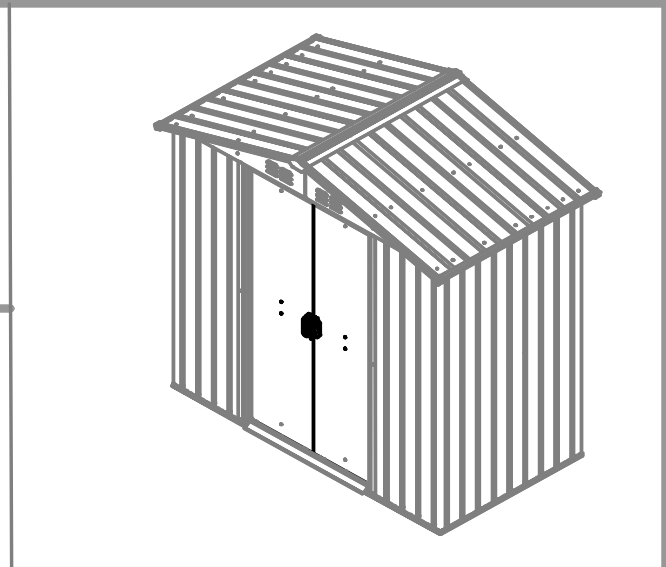
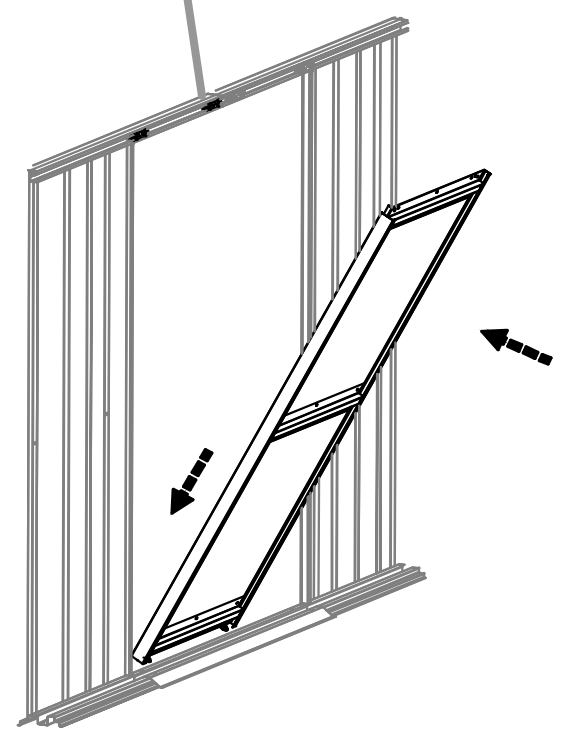
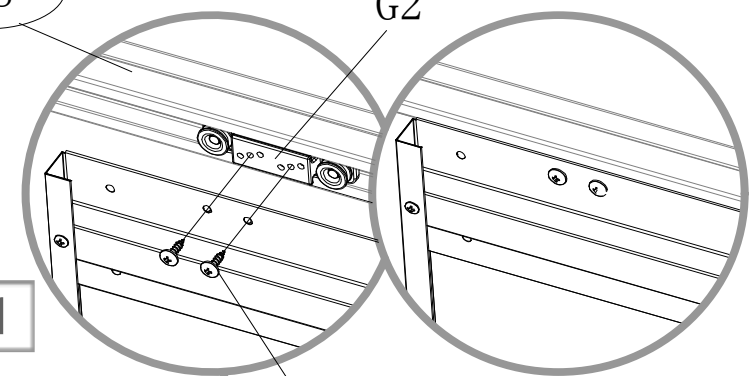



J1 (×4)

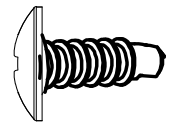

F7 (×16)

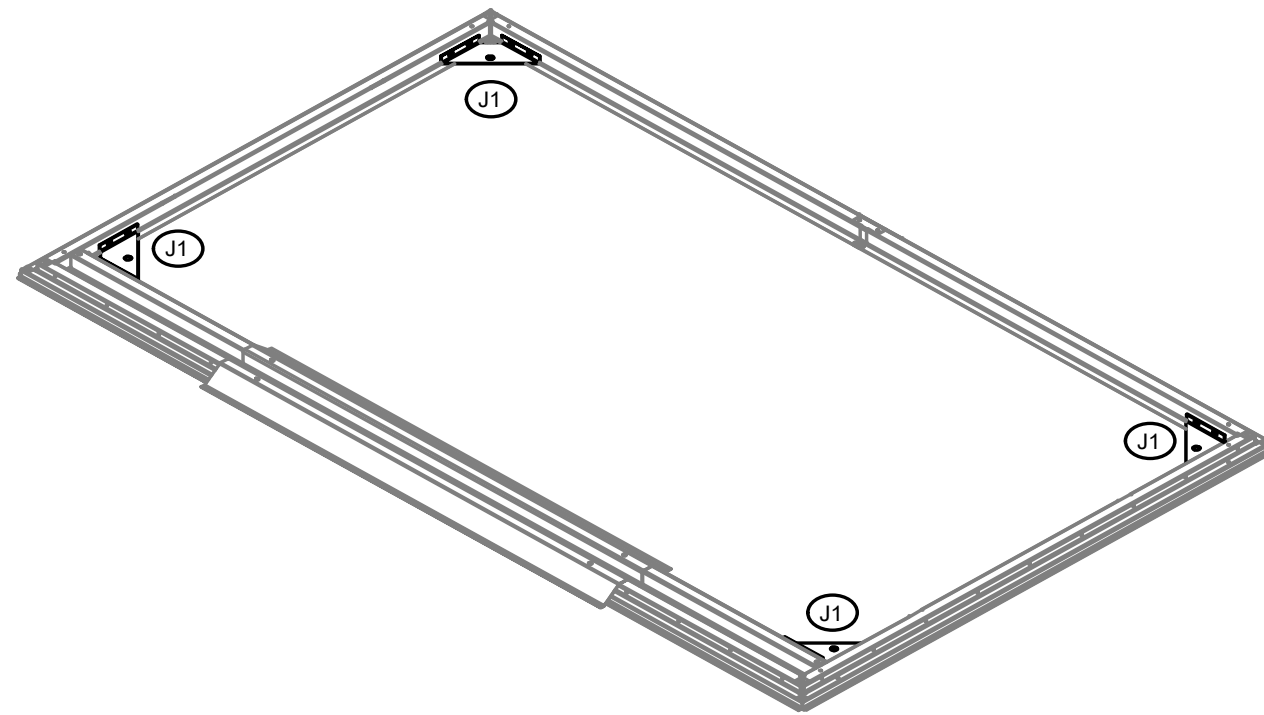
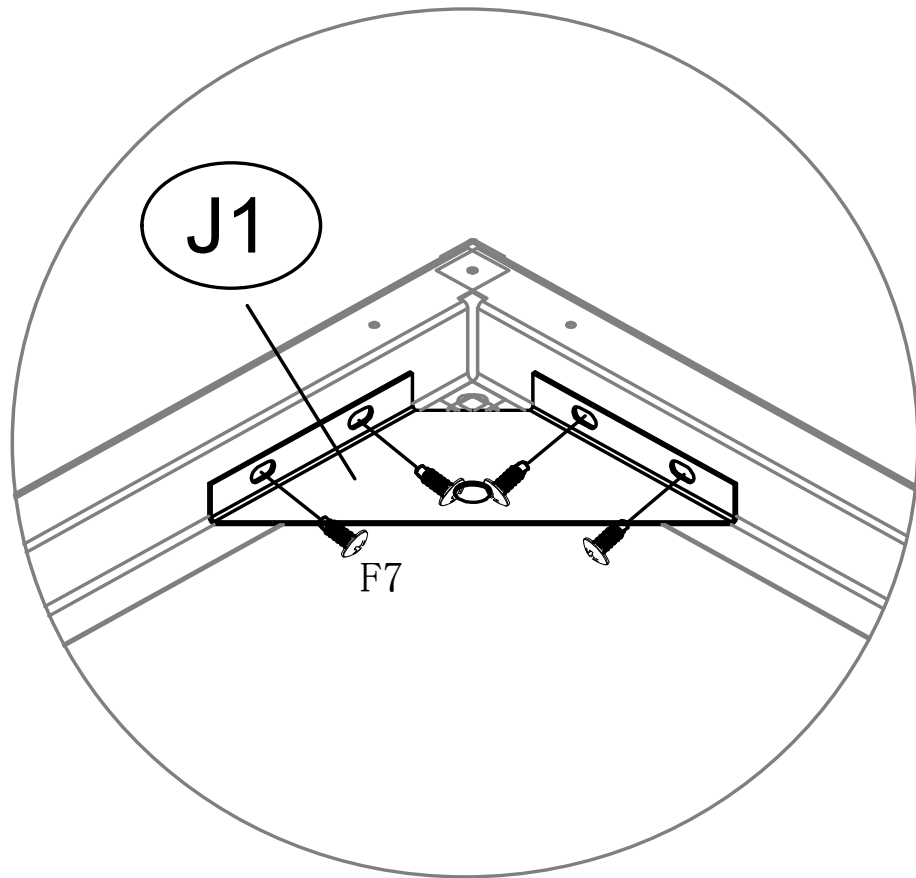

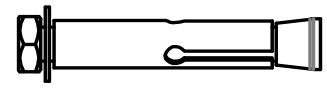

F10 (×4)

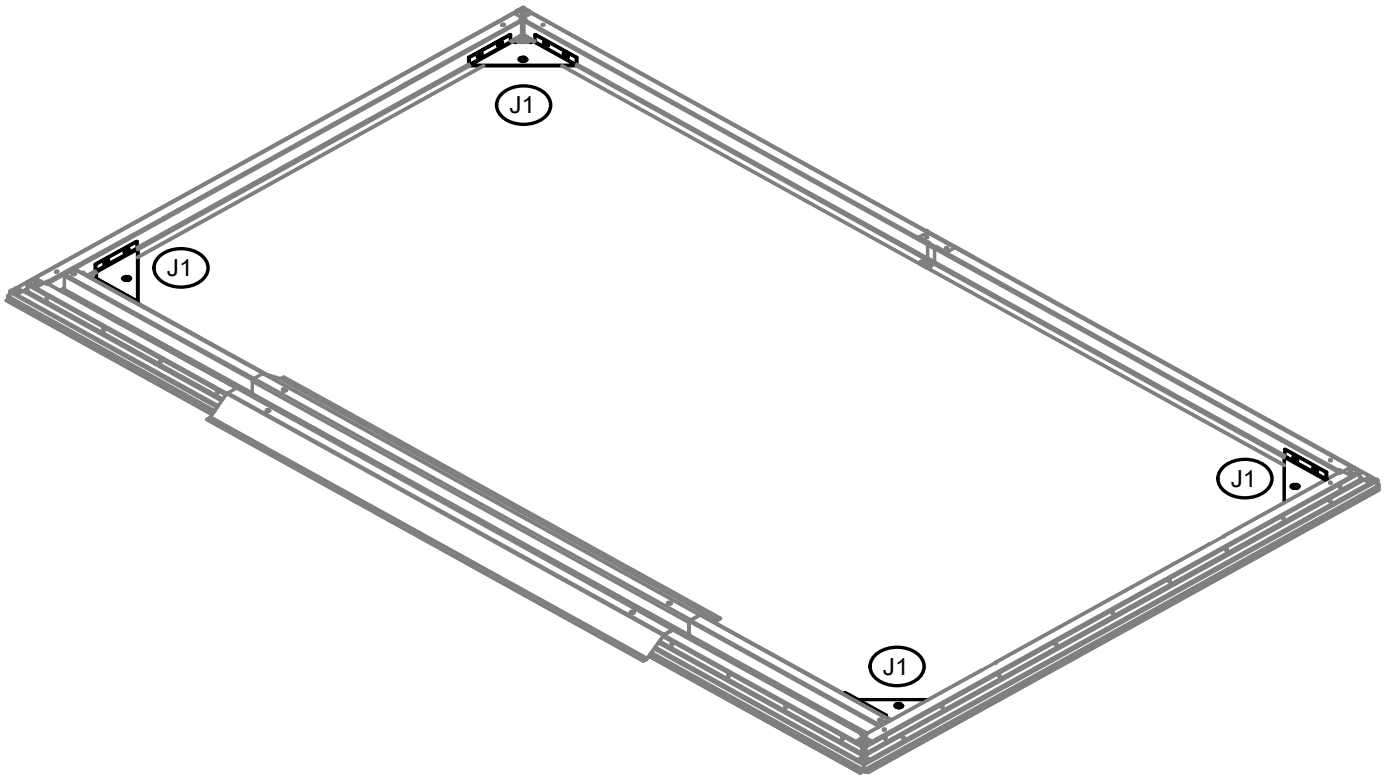
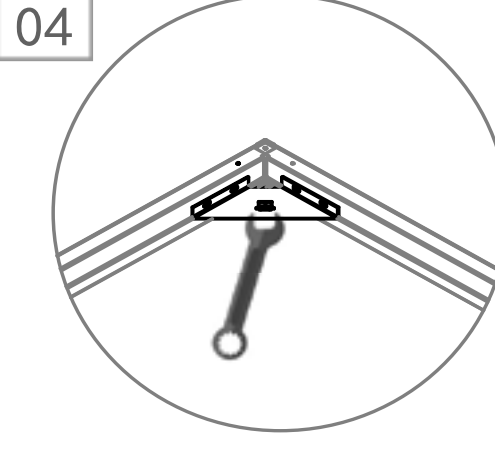
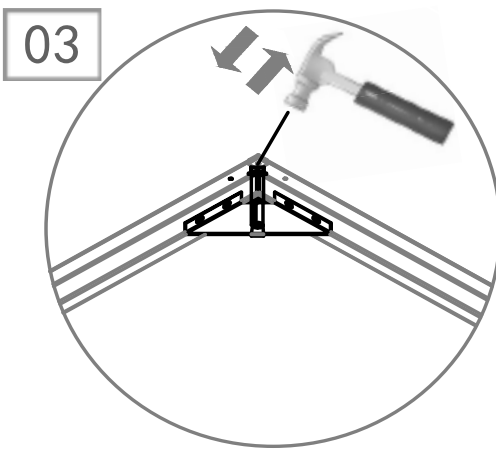
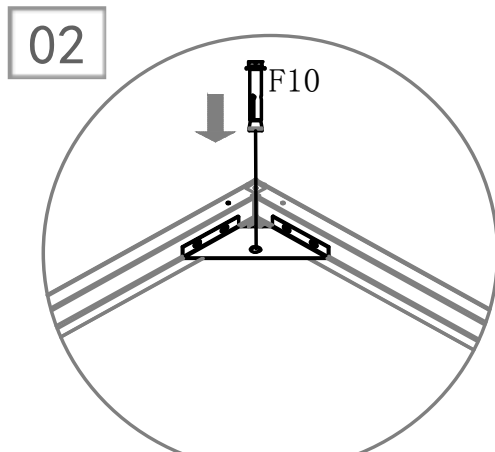
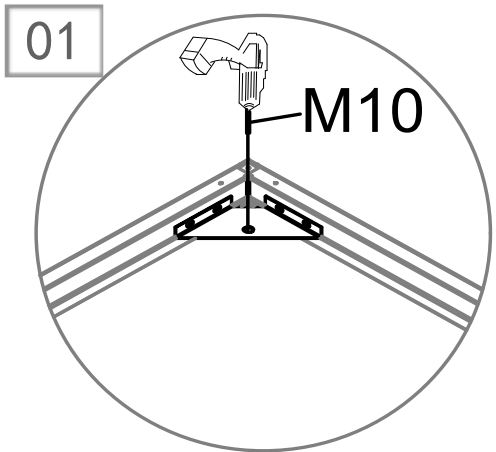

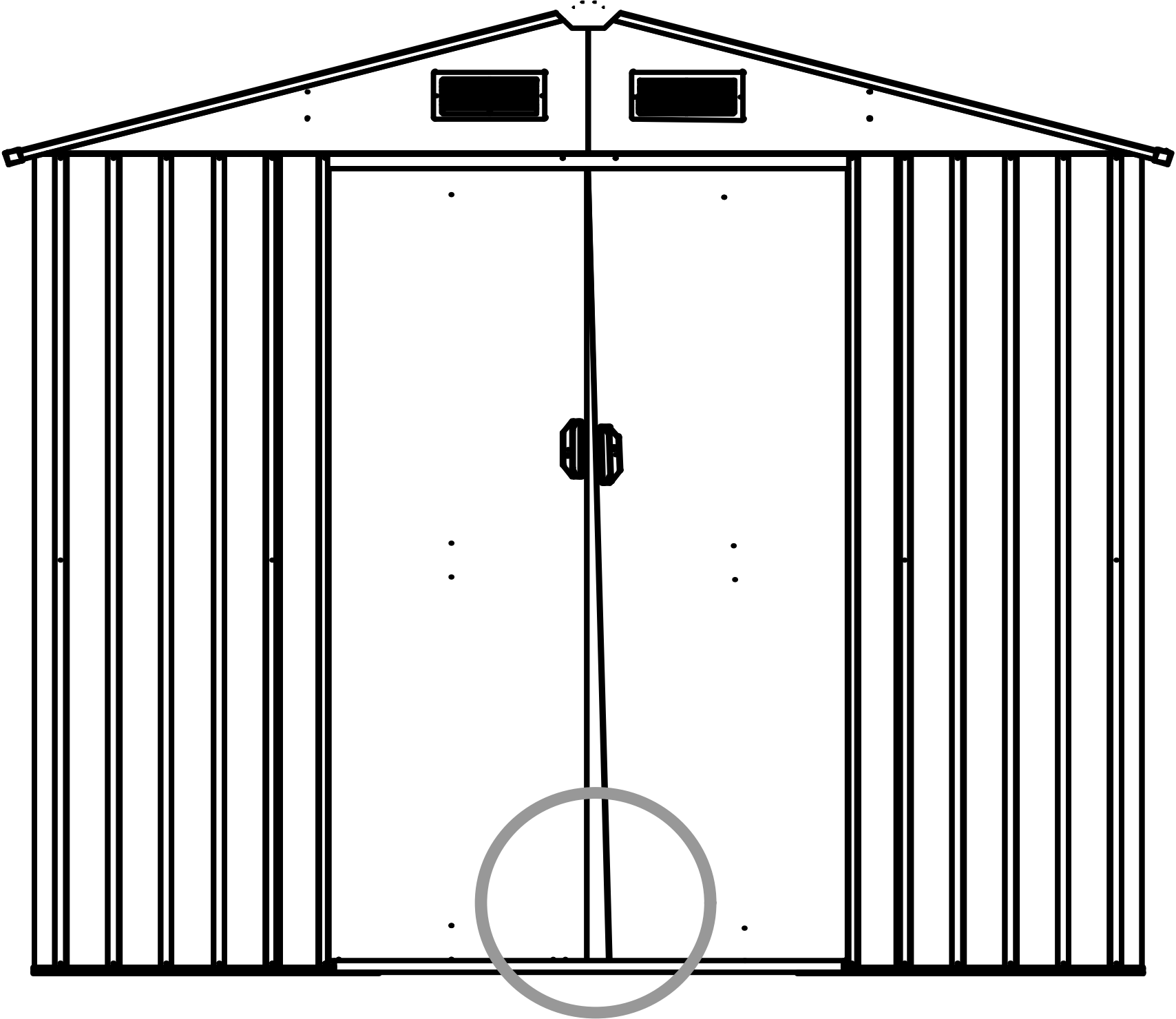

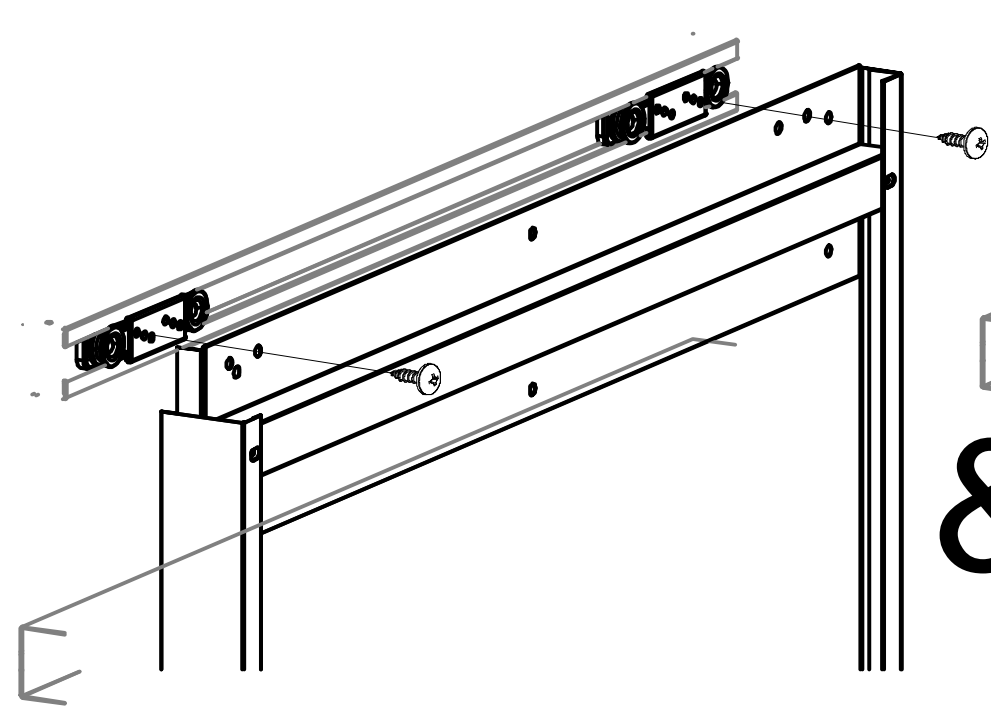
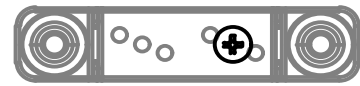
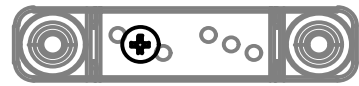

&

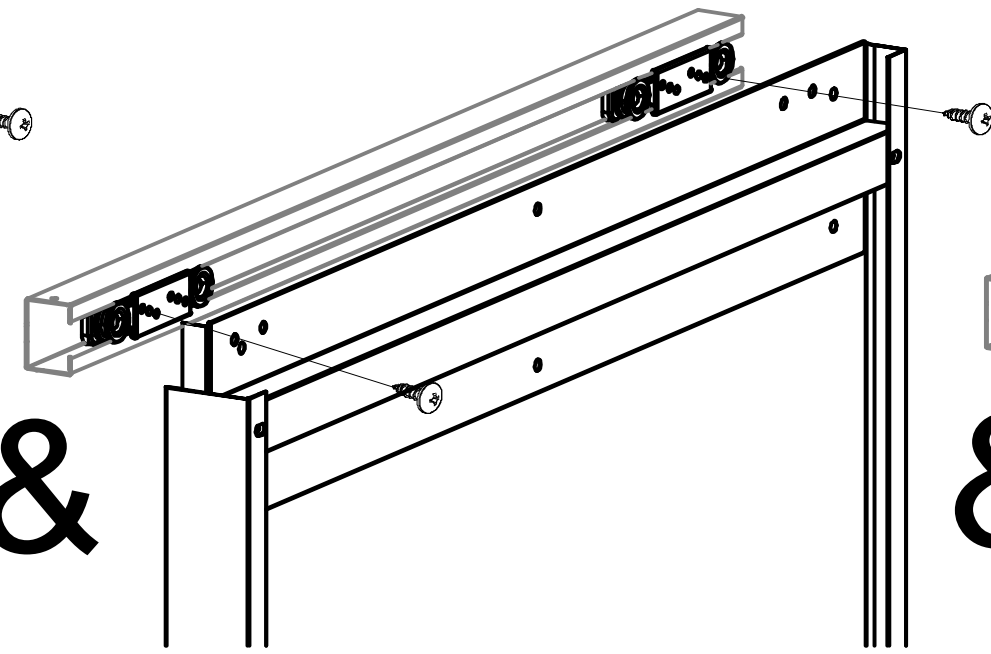

&

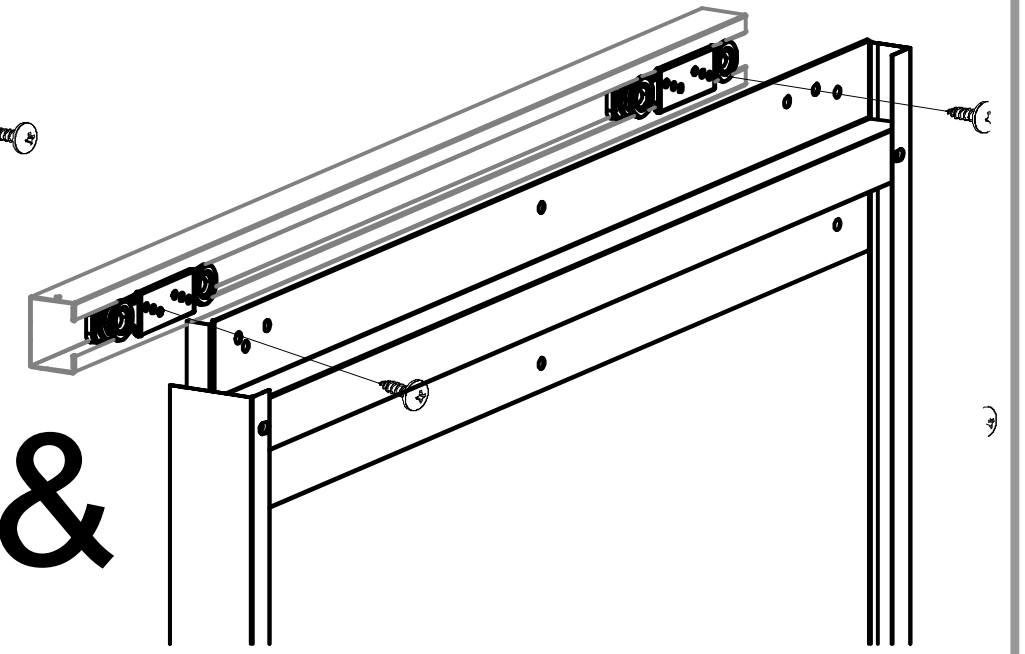

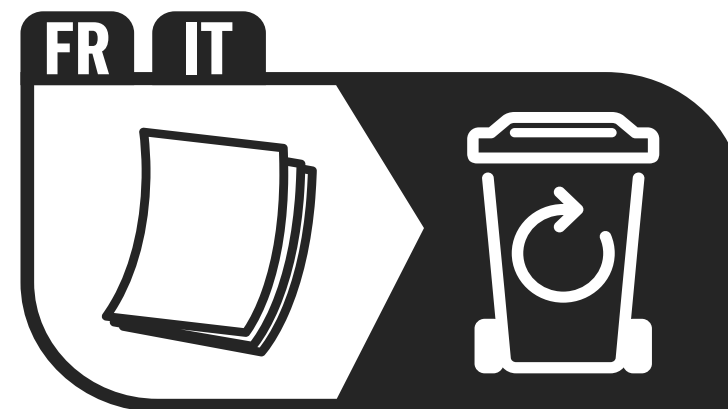

DESCARTE SELETIVO