

METAL SHED

GALVANIZED STEEL
0,3MM APEX ROOF 4.6M²

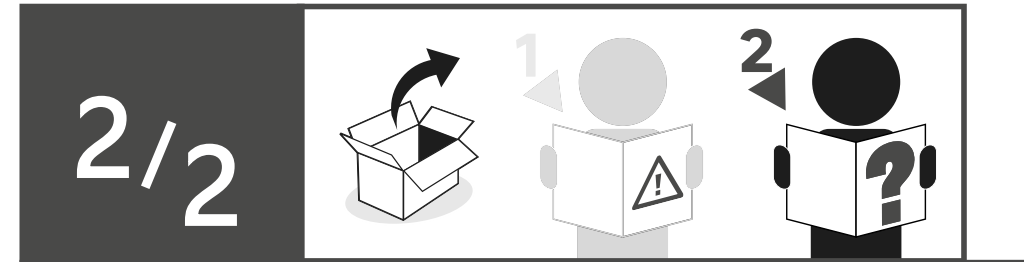

EAN :3276007881325
MATRIX ID :2025R09P11-0021

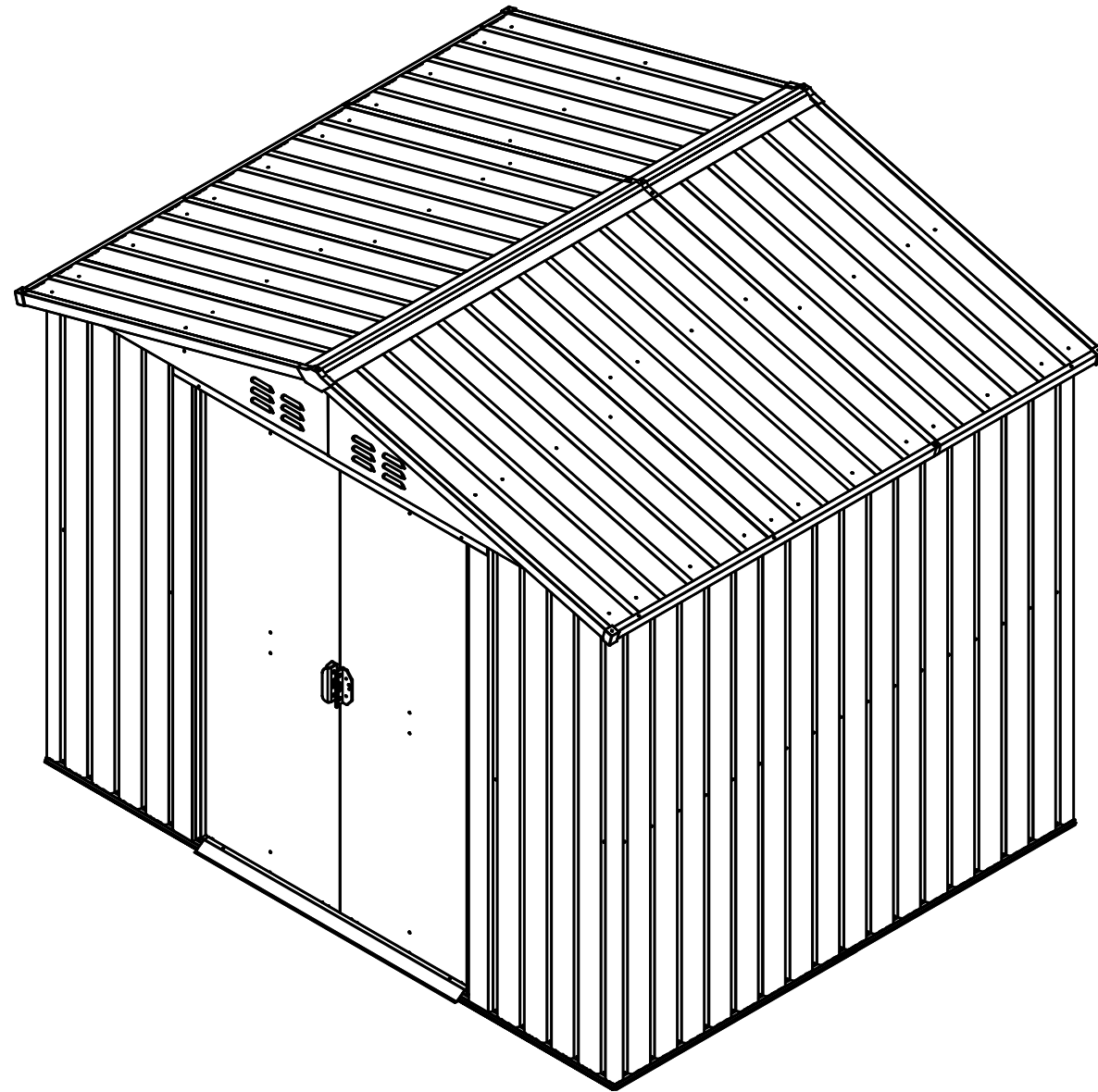
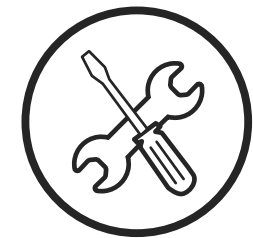

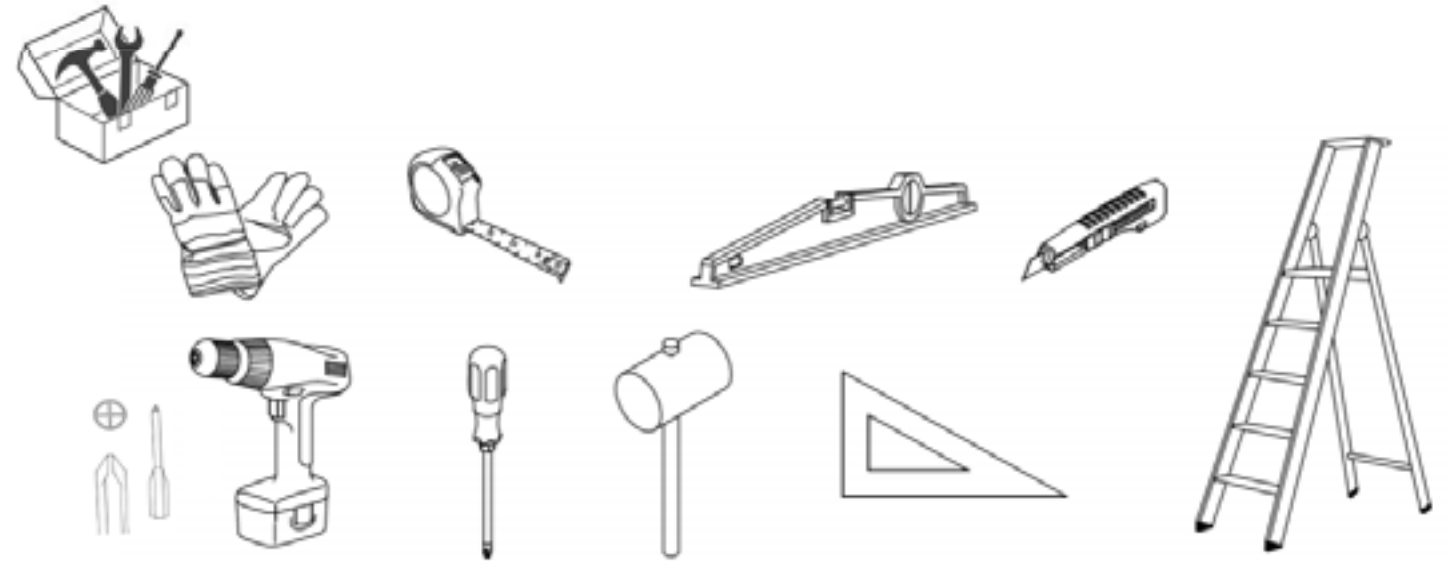

max.75kg/ m²

max.90km/h

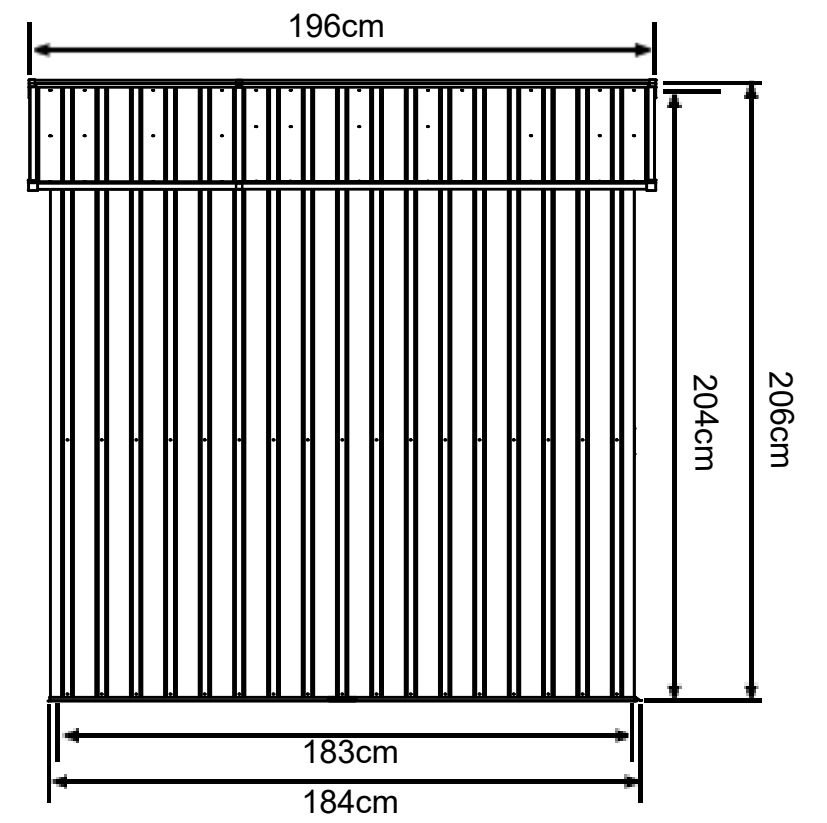
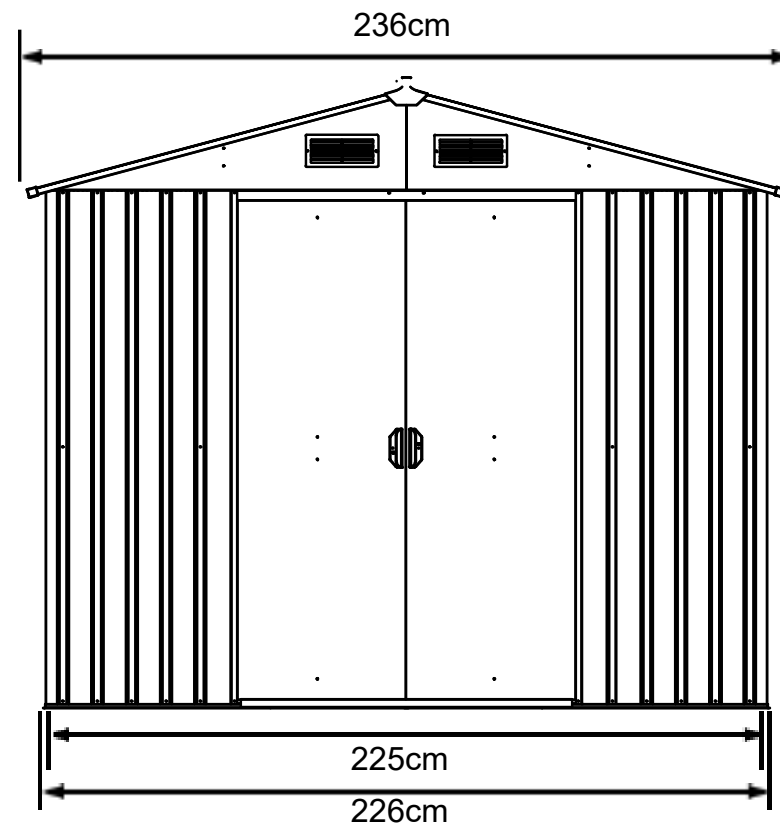







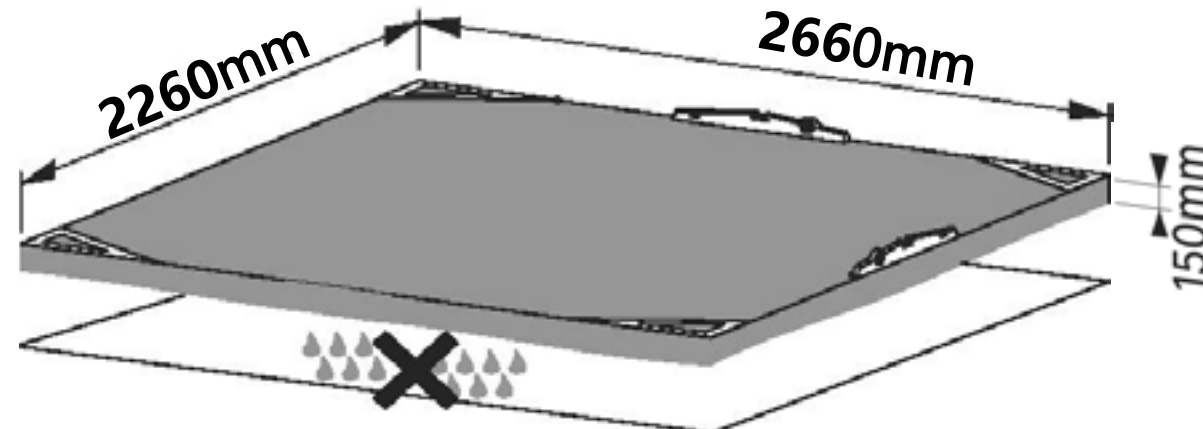

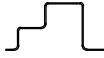

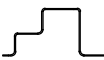





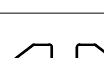





































FR Sol nivelé requis	ES Es necesario un suelo nivelado	PT É necessário um solo nivelado
IT È richiesto un fondo livellato	EL Απαιτείται επίπεδο έδαφος	PL Wymagane wyrównanie i wy poziomowanie podłoża
UA Необхідно забезпечити рівну ділянку землі	RO Necesar teren plat	EN Level ground required

- [ER] Pose sur dalle béton parfaitement plate et de niveau (non incluse)
- [ES] Colocar sobre losa de hormigón perfectamente plana y nivelada (non incluida)
- [PT] Montagem sobre laje de betao perfeitamente plana e nivelada (não incluída)
- [IT] Posare su pavimenti in cemento perfettamente in piano e livellato (non incluso)
- [EL] Πρέπει να τοποθετείται πάνω σε απόλυτα επίπεδη και οριζόντια πλάκα σκυροδέματος (δεν περιλαμβάνεται)
- [PL] Montaż na idealnie płaskiej i wy poziomowanej płycie betonowej (brak w zestawie)
- [UA] Укладання на ідеально рівну і вирівняну бетонну плиту (не входить у комплект)
- [RO] Montare pe dală de beton perfect plată și la nivel (nu este inclusă)
- [BR] Instalação em uma laje de concreto perfeitamente plana e nivelada (não incluída).
- [EN] Installed on a perfectly flat and level concrete slab (not included)



NO.	PART	Qty.
1L	 955mm	2
1R	 955mm	2
2L	 1169mm	1
2R	 1169mm	1
3L	 702mm	1
3R	 702mm	1
4L	 1720mm	1
4R	 1720mm	1
5	 1032mm	1
6	 1090mm	1
7	 1105mm	1
8	 1105mm	1
9	901mm	2
10L	1118mm	1
10R	1118mm	1
11	901mm	2
12	353.5mm	2
13	959.3mm	2
14	959.3mm	2
16	1029.8mm	1
16-1	1029.8mm	1

NO.	PART	Qty.
22L	 904mm	2
22R	 904mm	2
23L	 1118mm	1
23R	 1118mm	1
17	 1179mm	4
15-1	 1302mm	1
15-2	 1302mm	1
24-1	 660mm	1
24-2	 660mm	1
19	 1304mm	1
20	 662mm	1
21L	 2	2
21R	 2	2
18	 548mm	6
B1	 139mm	2
B2	 139mm	2
B3	 286mm	2
B4	 286mm	2
6-1	 1	1
6-2	 1	1
J1	 4	4

NO.	PART	Qty.
P1	 1720mm	2
P2	 1720mm	2
P3	 1720mm	4
P4	 1720mm	4
P5	 1207mm	2
P6	 1207mm	2
P8	 1207mm	2
G2	 4	4
GD	 4	4
GS	 4	4
GB	 2	2
GC	 4	4
GE	 2	2
F1	 ST4.2X10mm	348
F2	 M4X10mm	55
F3	 ST4.8X16mm	8
S2	 260	260
S3	 320	320
F10	 4	4
F7	 16	16

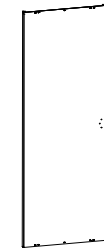
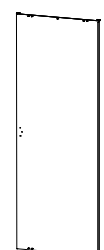
NO.	PART	Qty.
D1	 1710X552mm	1
D2	 1710X552mm	1

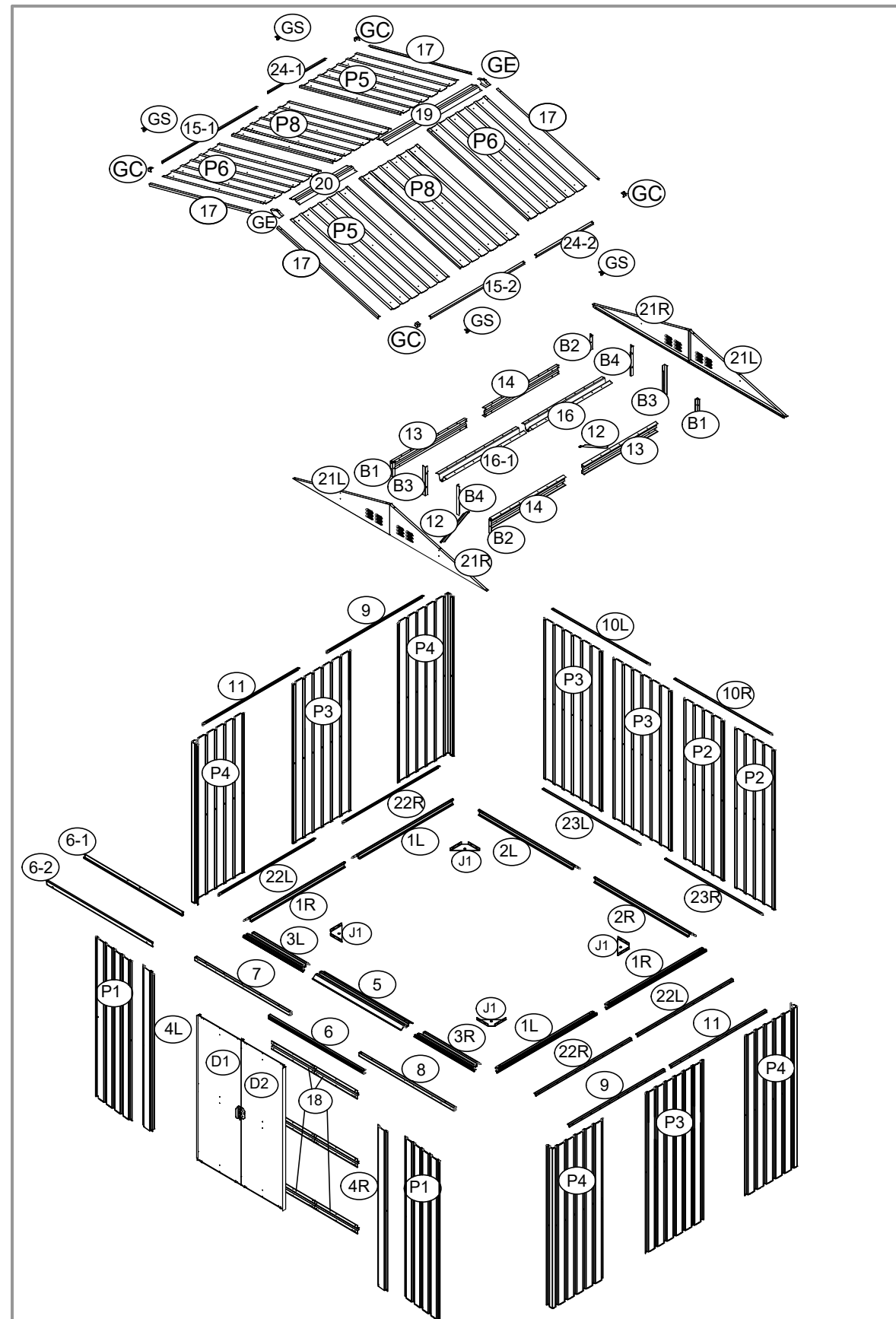

Picto for assembly

01

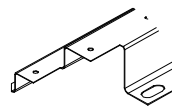

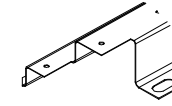
1L (×2)

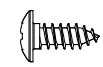
1R (×2)

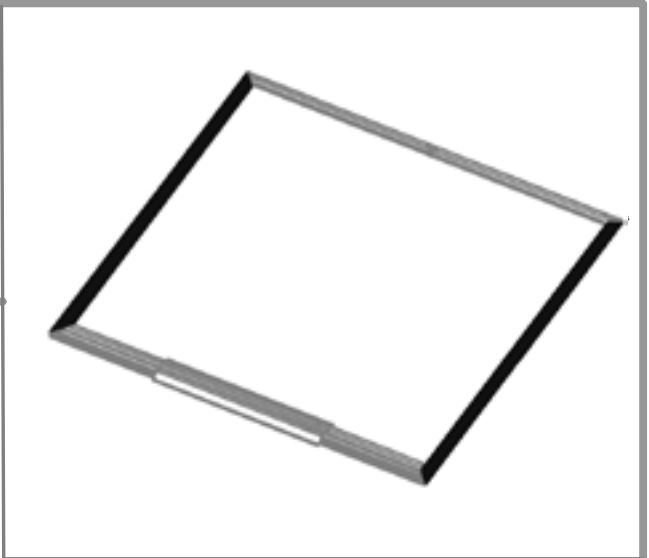

F1 (×8)

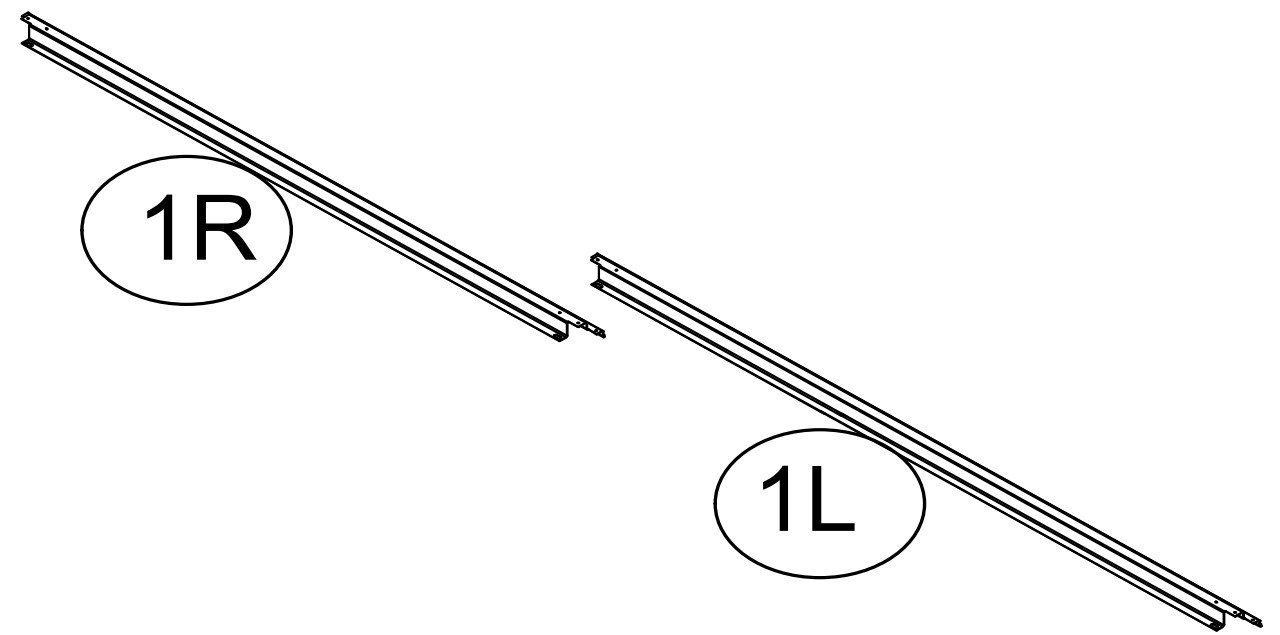
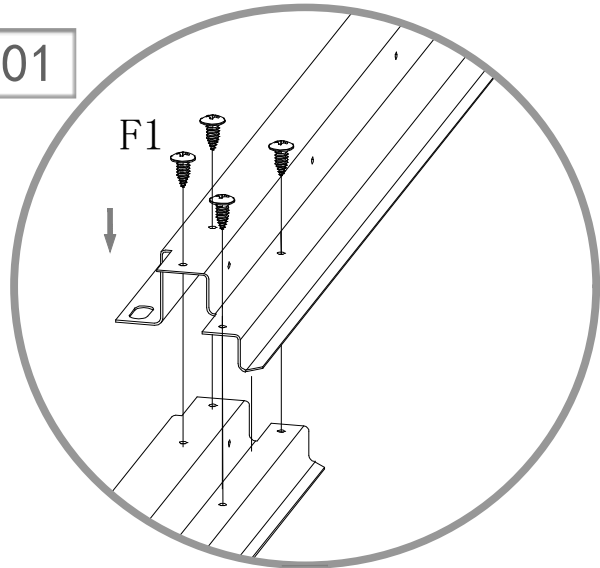

01

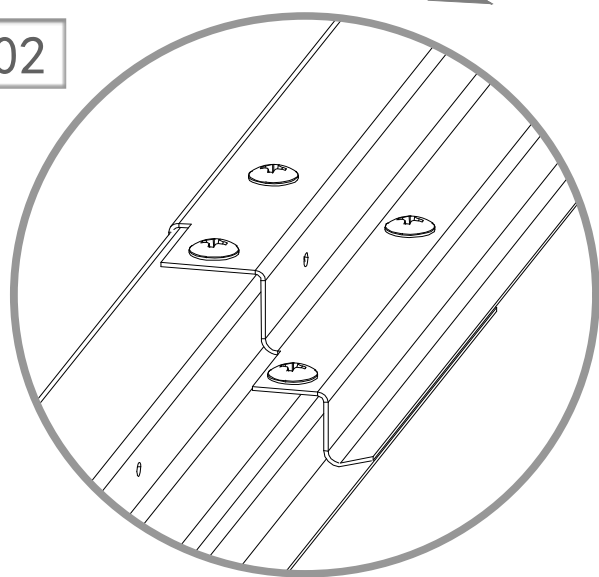

02



1L

x2

02

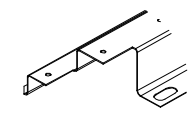

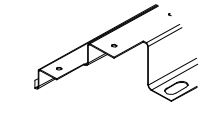
2L (×1)

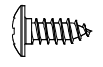
2R (×1)

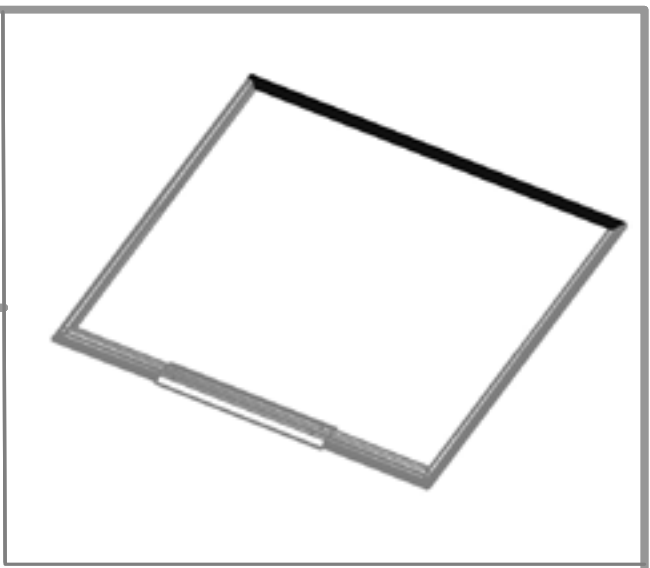

F1 (×4)

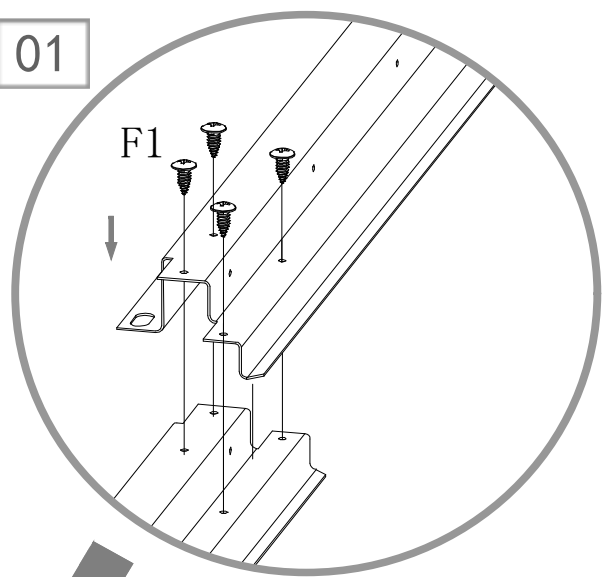

01

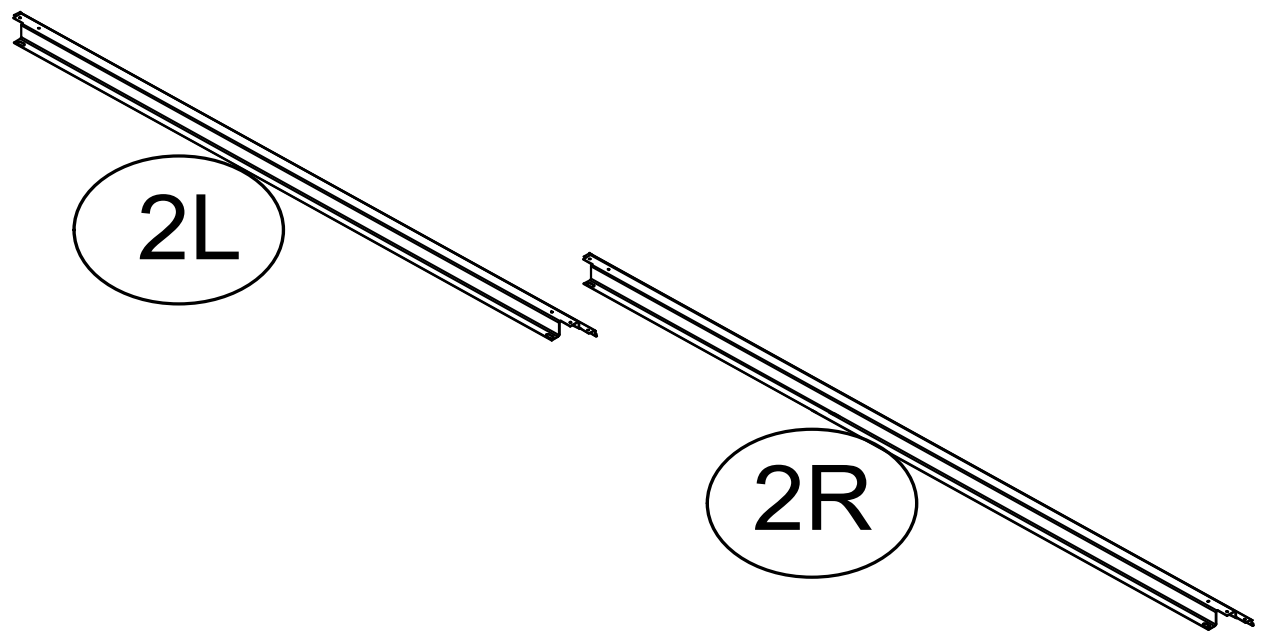
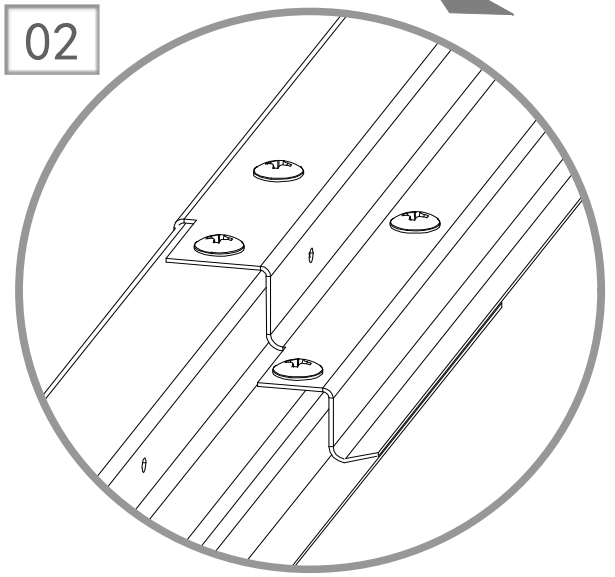

02



03

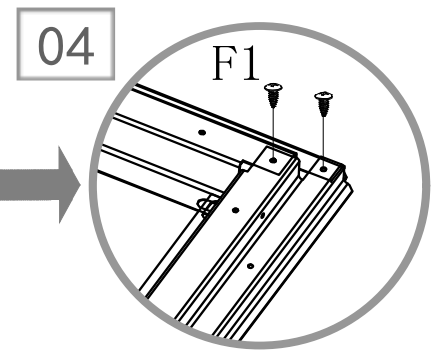
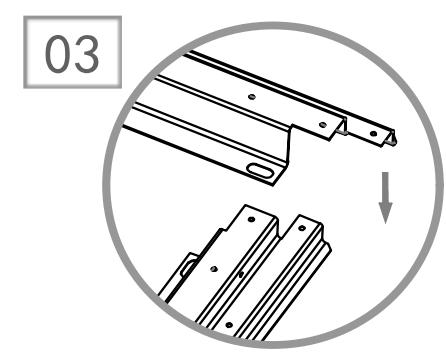
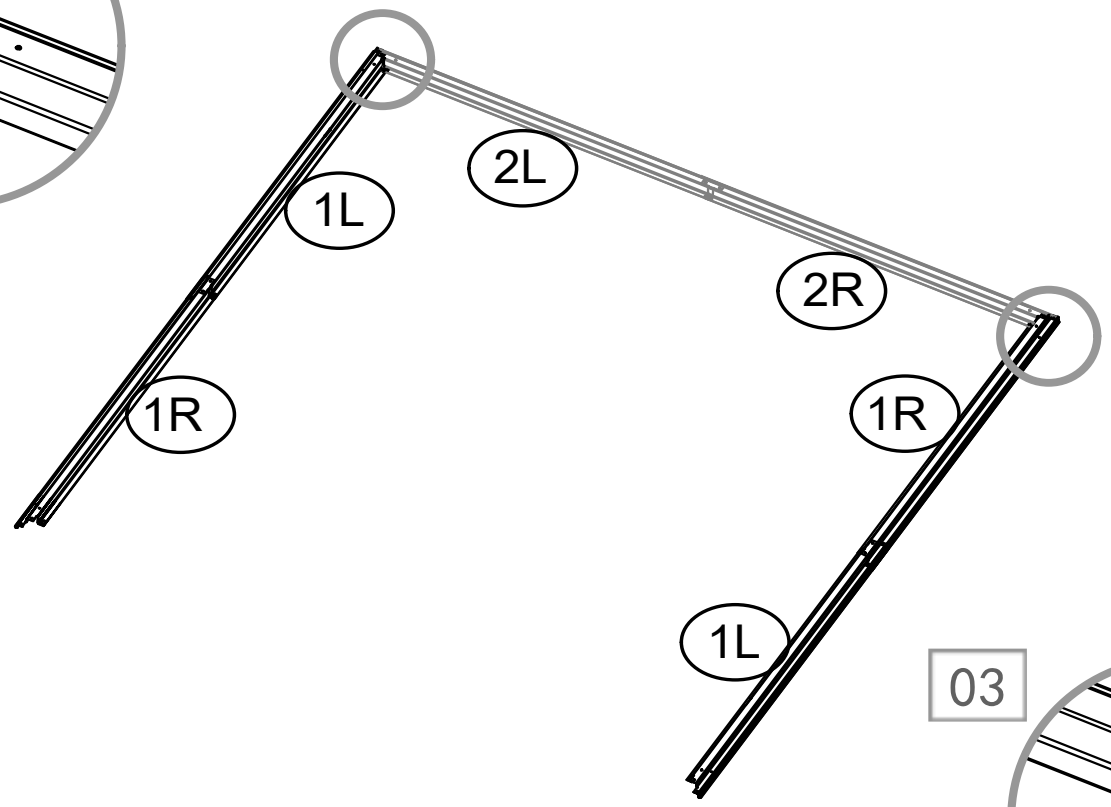
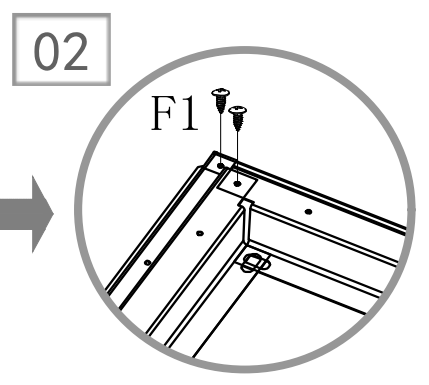
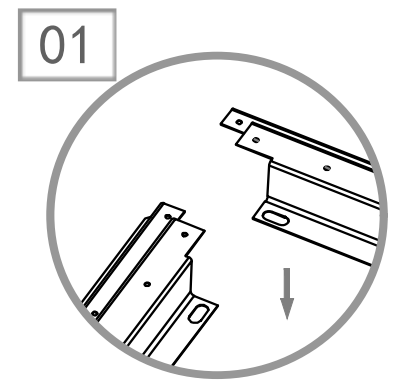
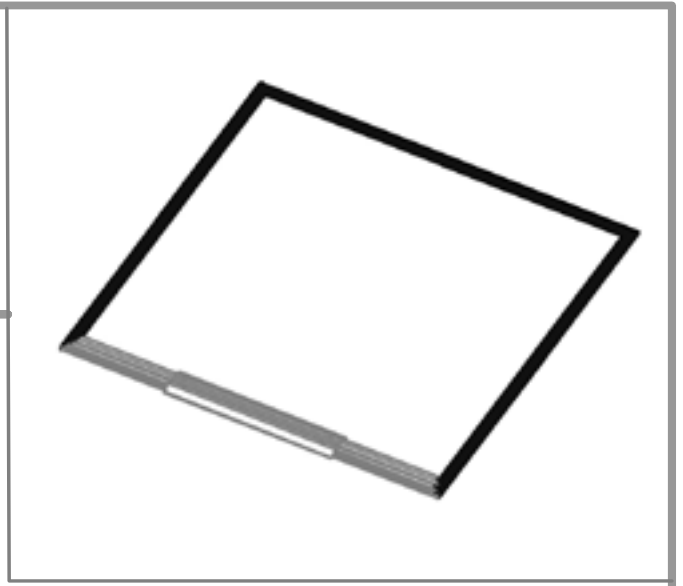

F1 (×4)

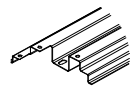

04

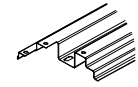

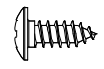
3L (×1)

3R (×1)

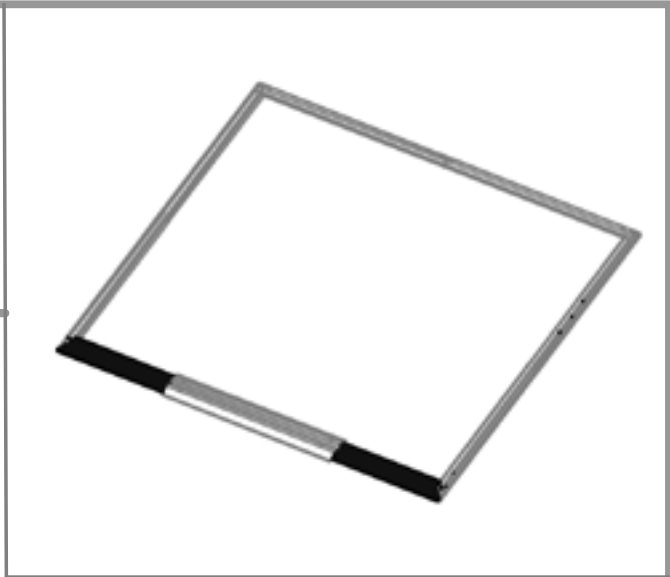

F1 (×4)

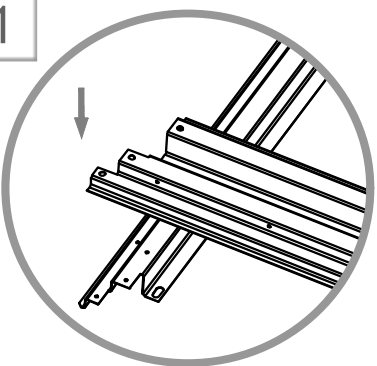

01

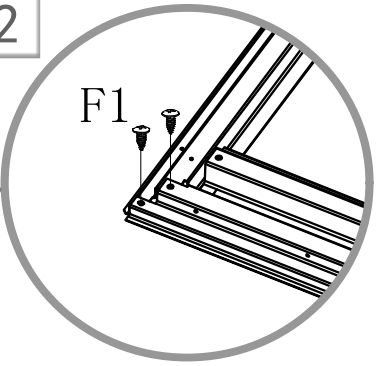

02



03

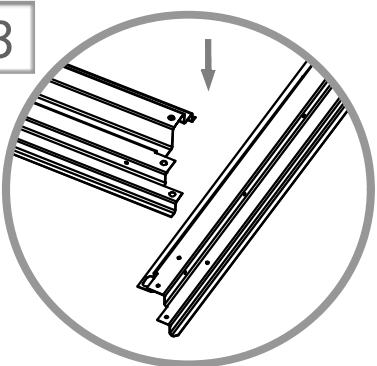

04

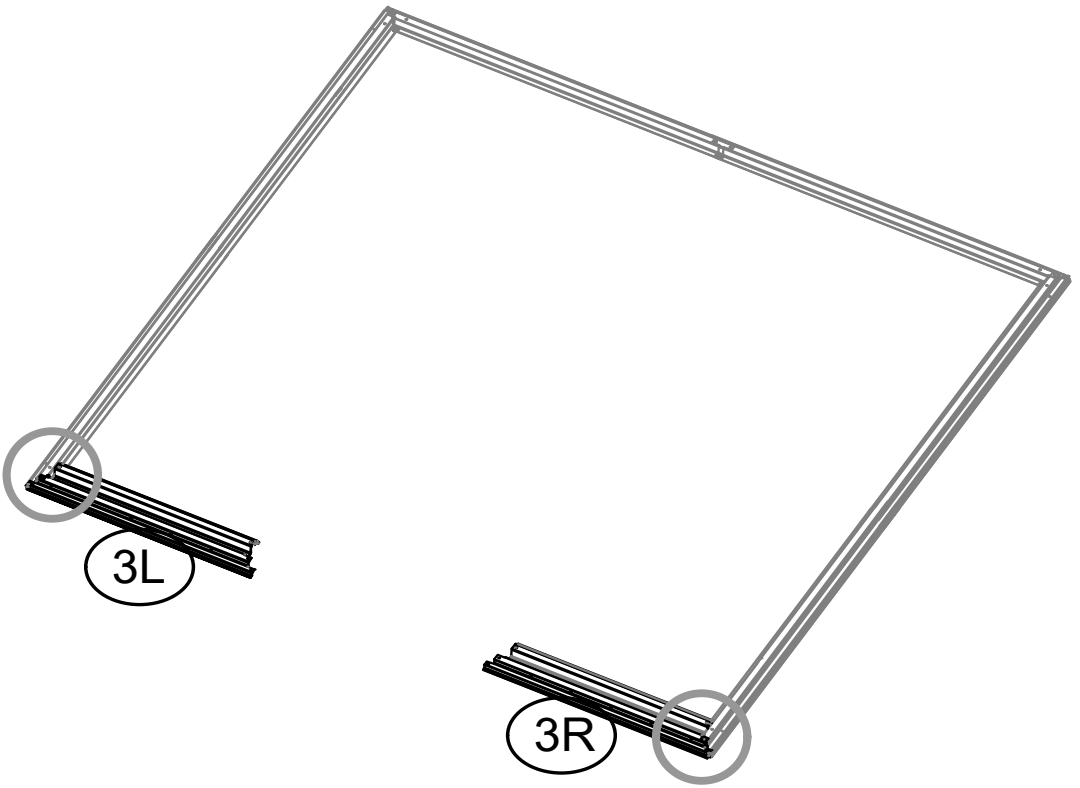
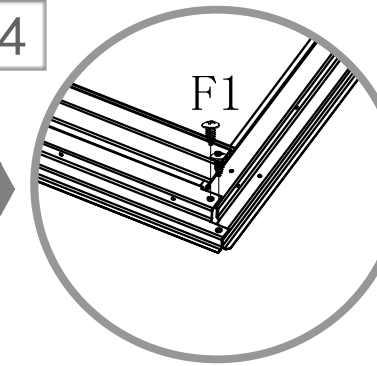

05

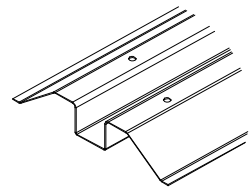

5 (×1)

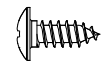

F1 (×4)

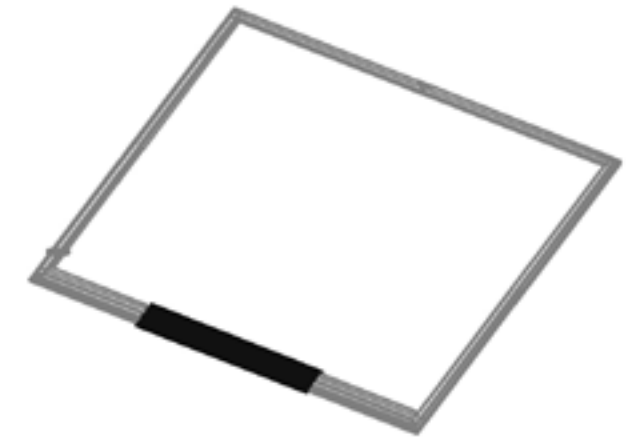

01

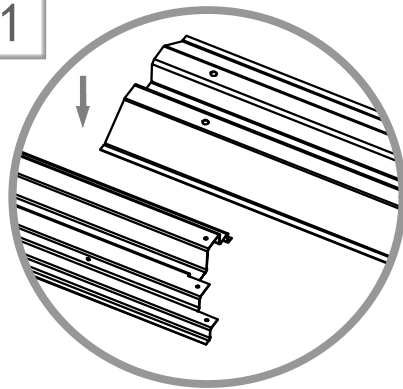

02

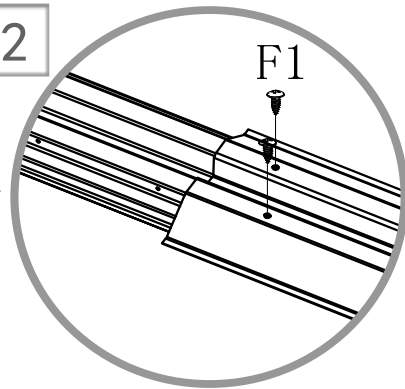

03

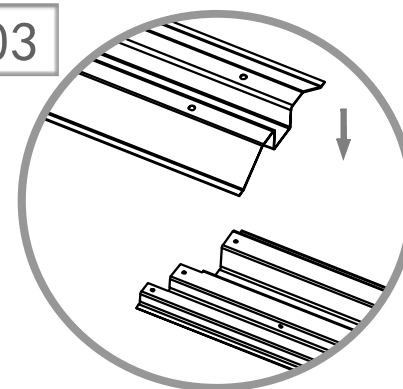

04

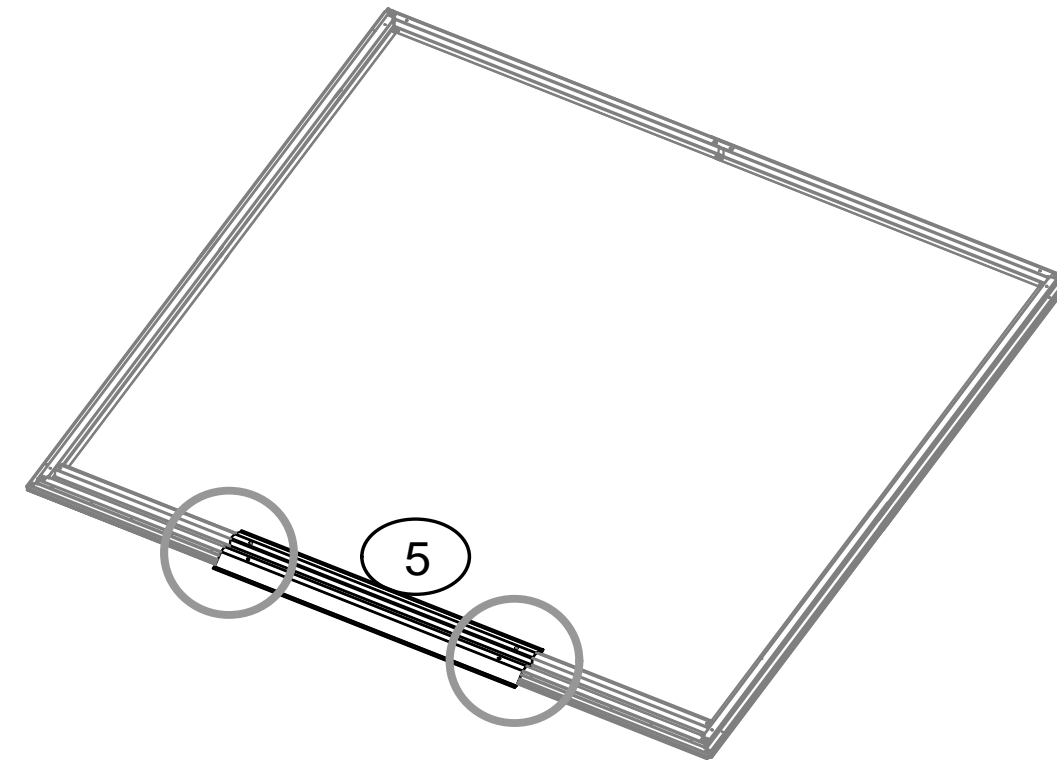
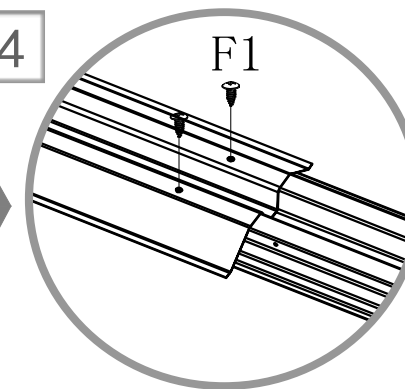

06

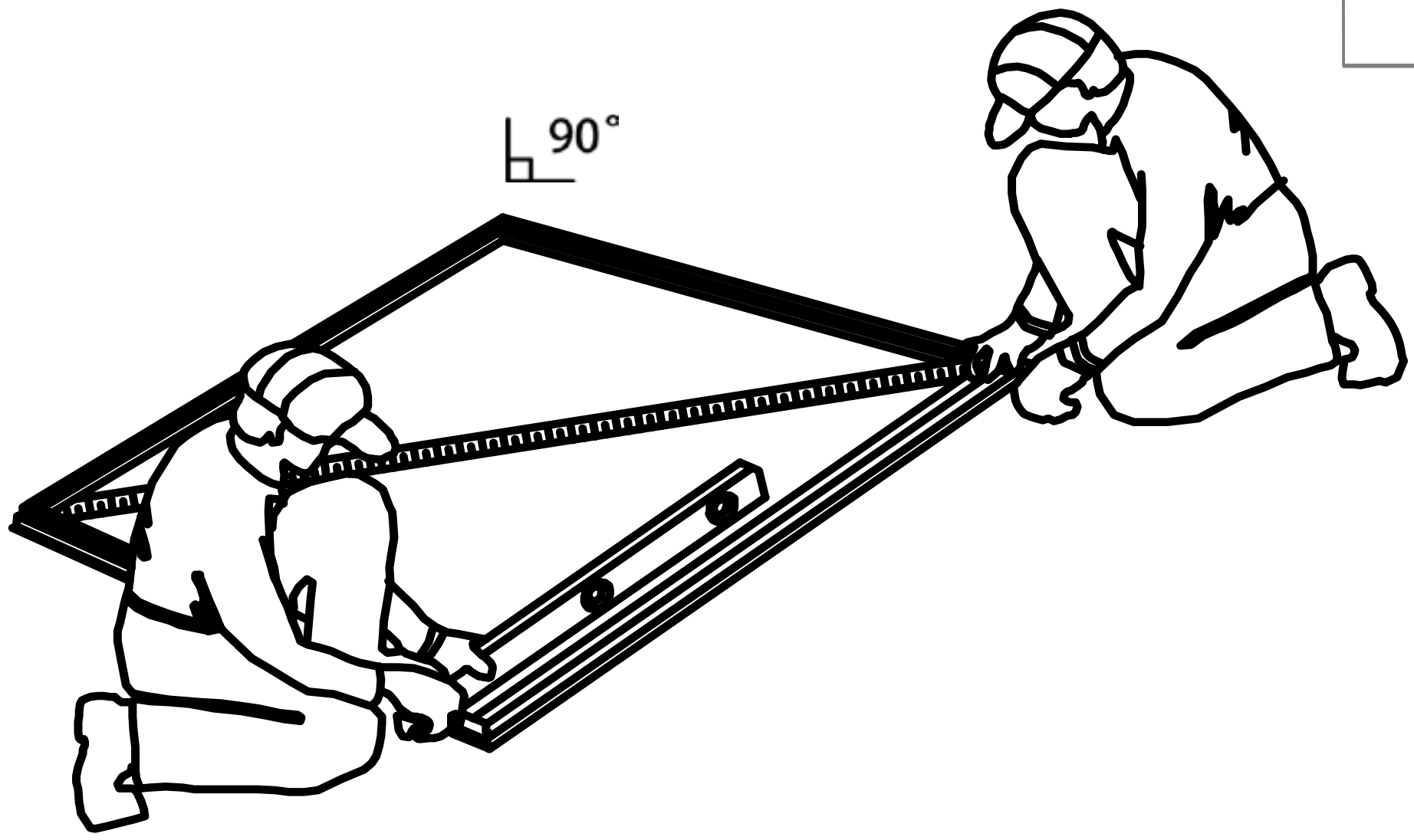
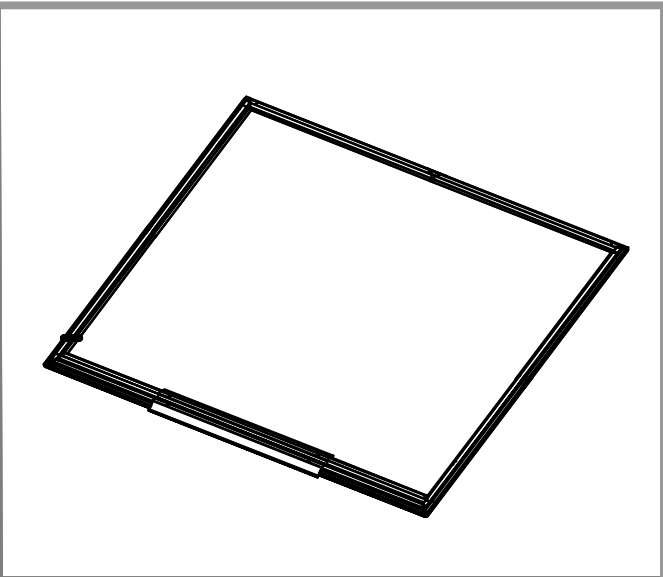

07

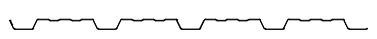

P1 (×1)



P4 (×1)

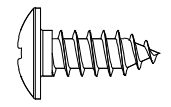

F1 (×9)



F2 (×1)

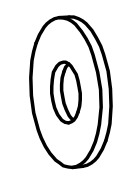

S3 (×10)

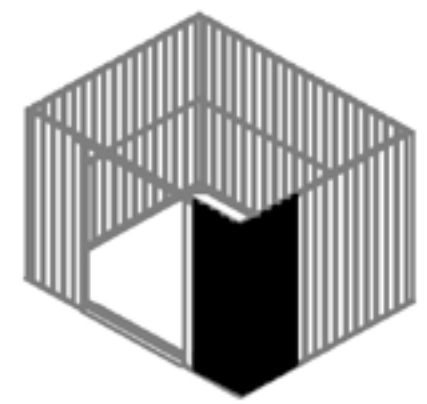

02

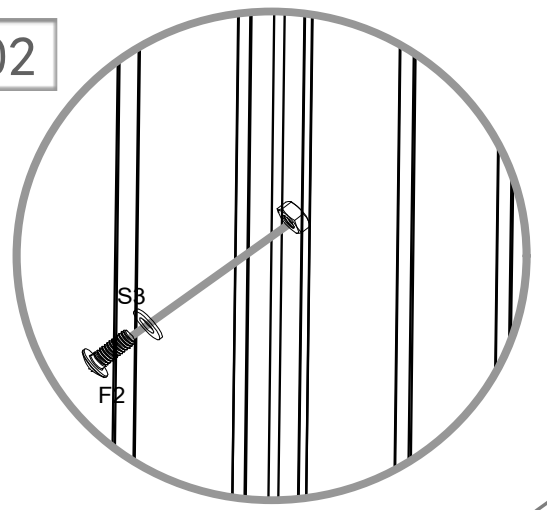

01

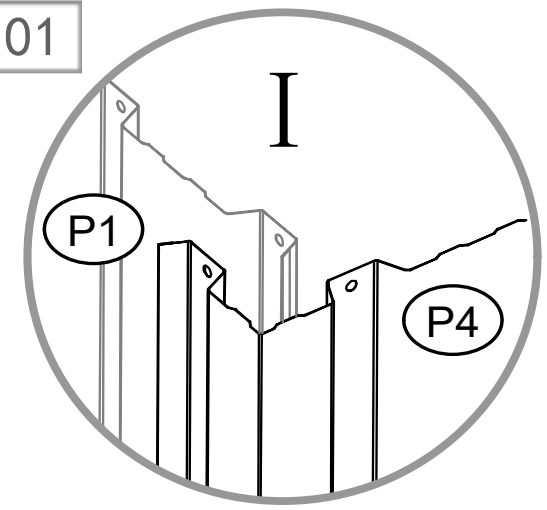

03

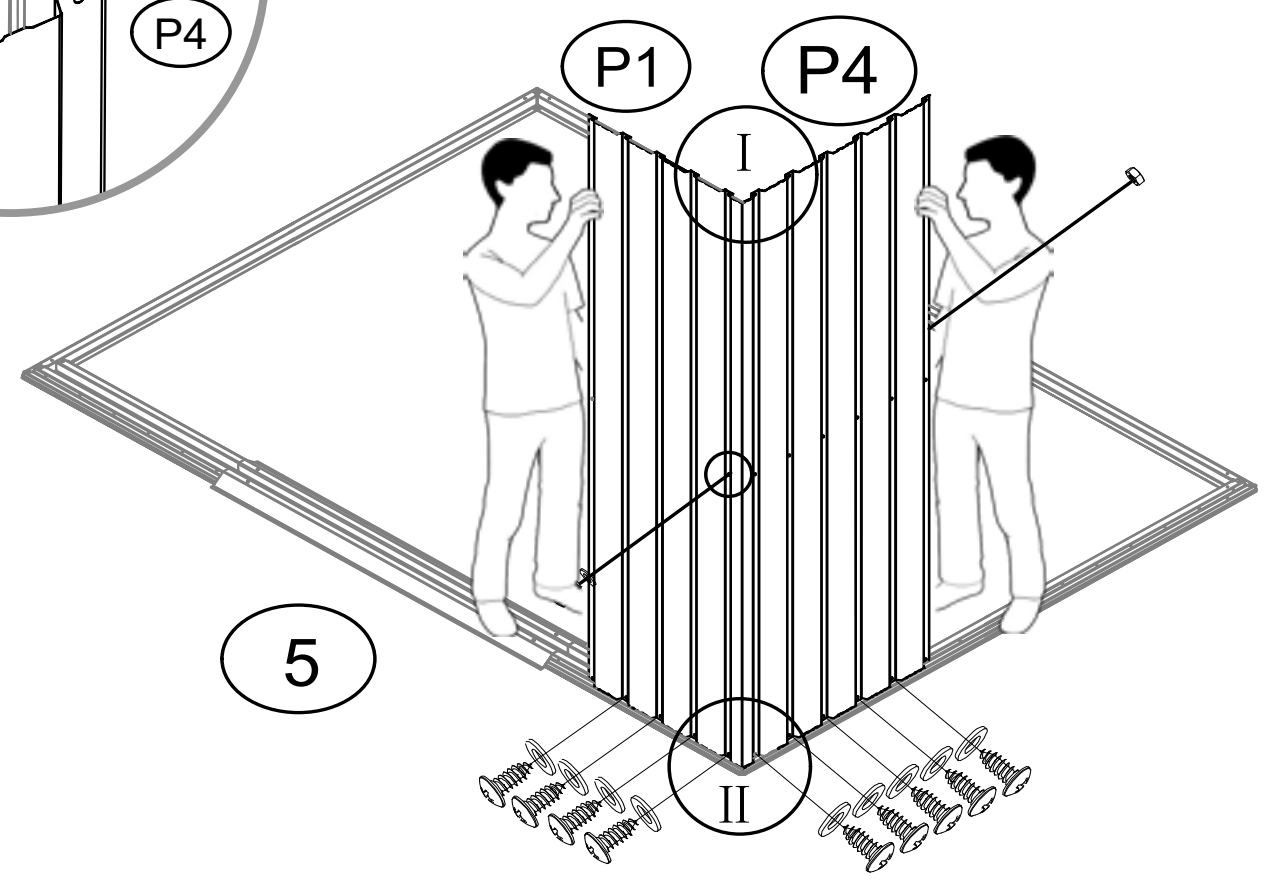
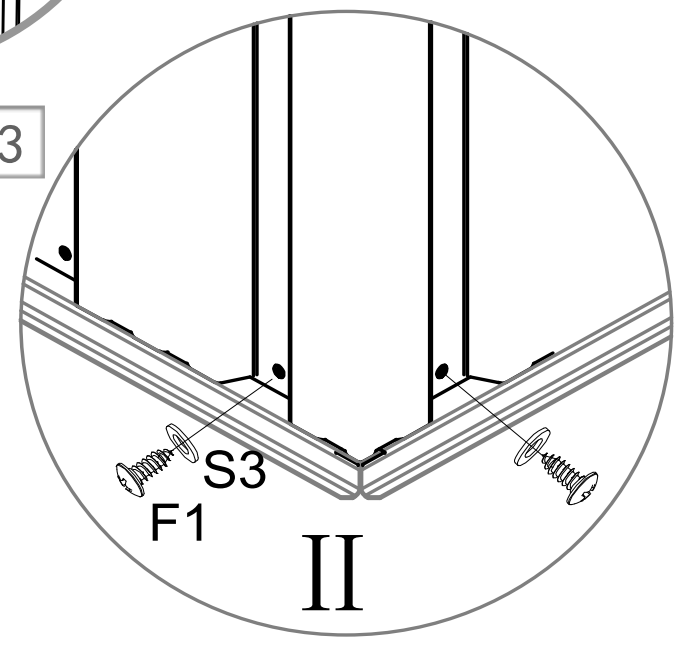

08

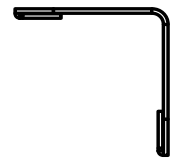

22R (×1)

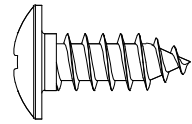

F1 (×5)



S3 (×5)

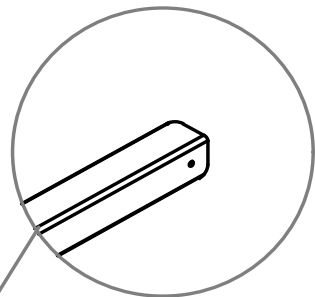
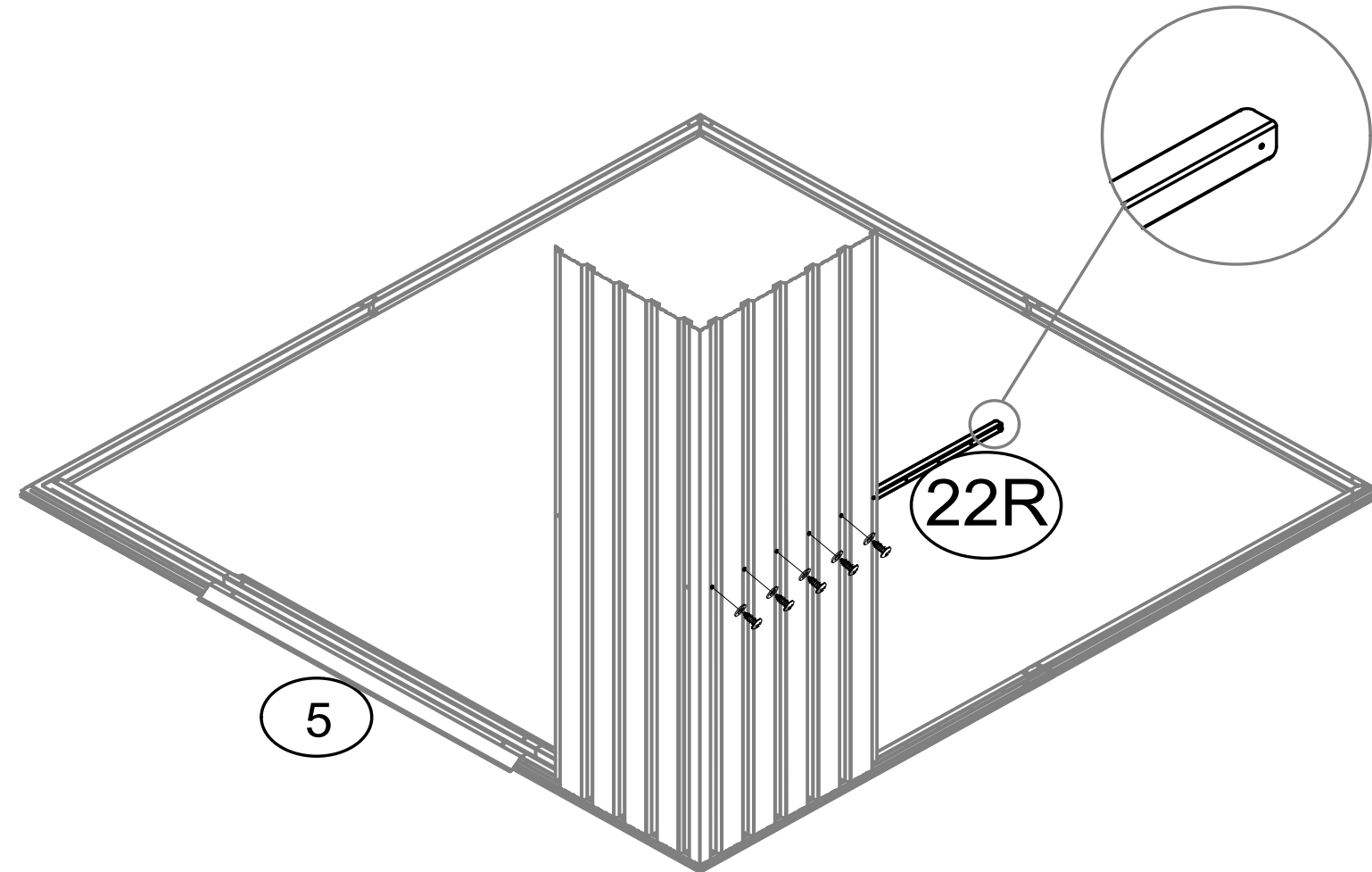
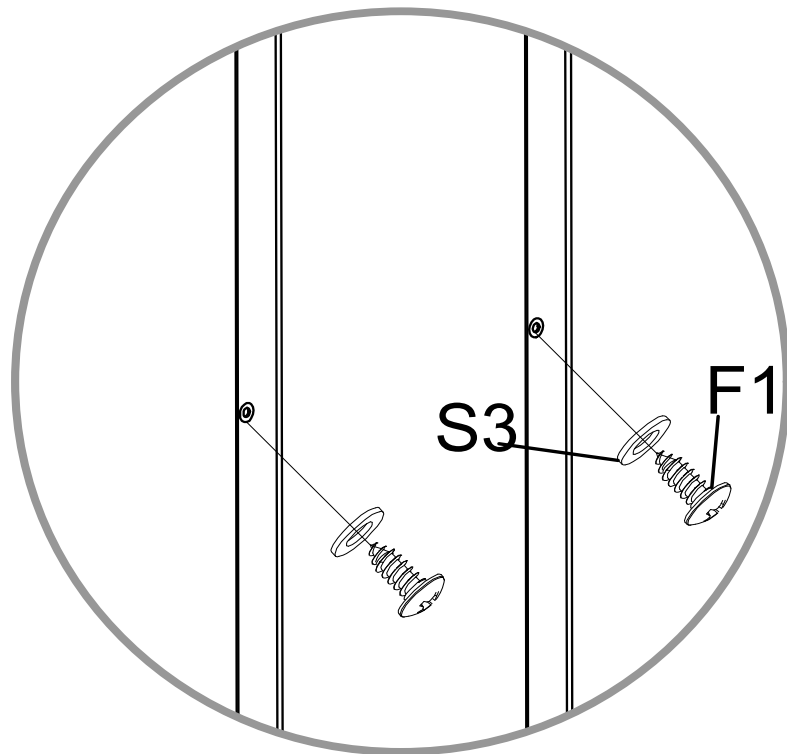
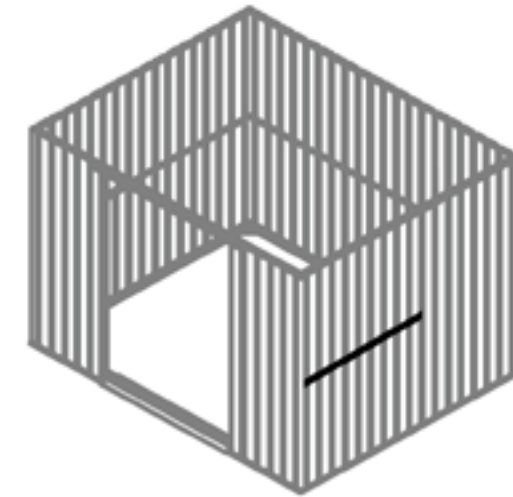

22R

5

09

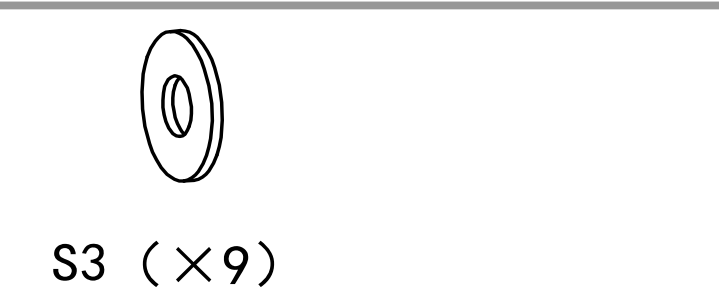
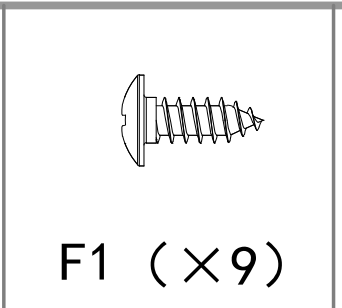
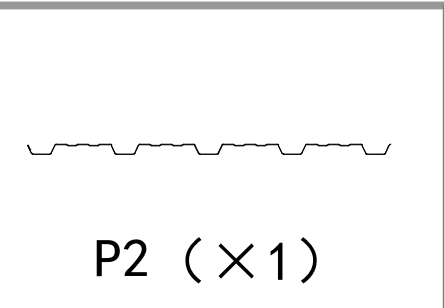

01

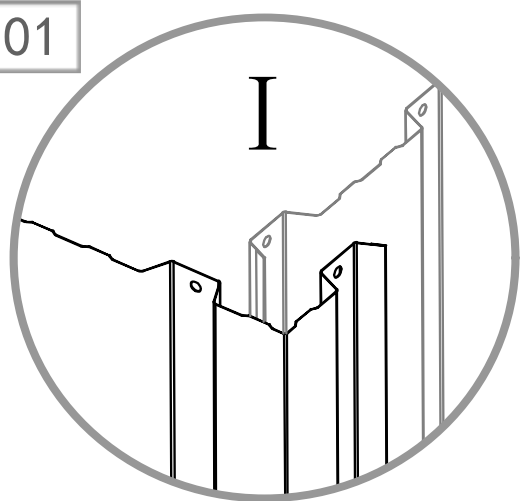

02

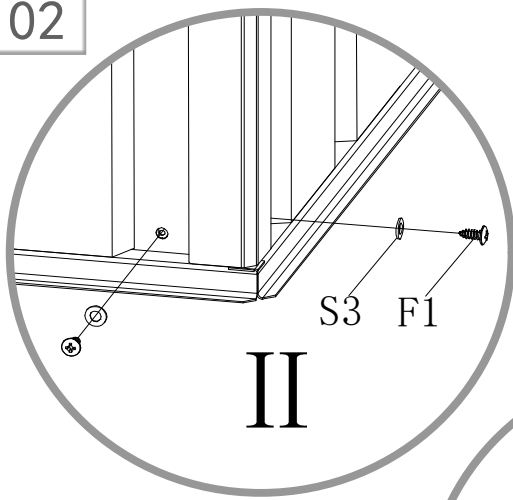

03

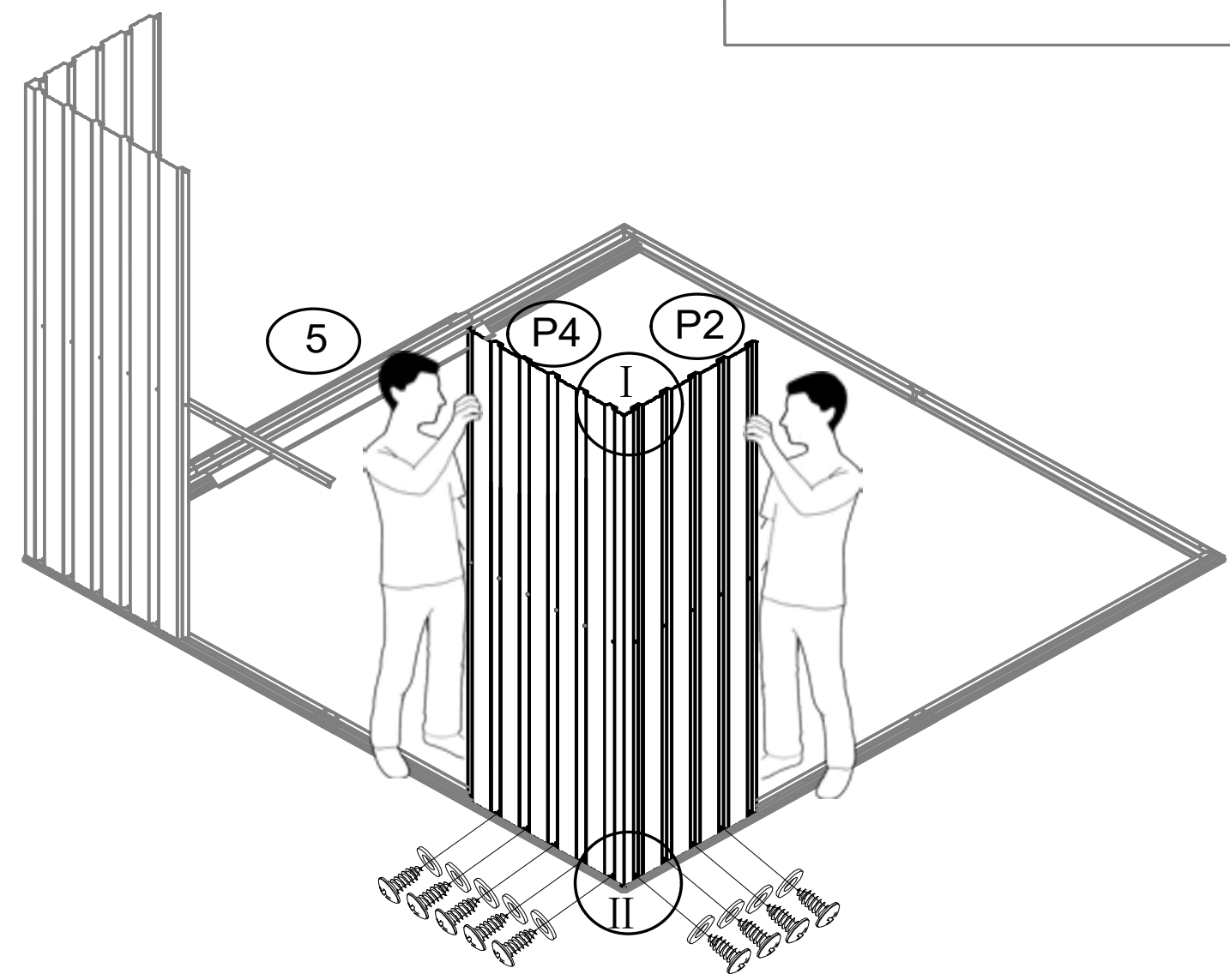
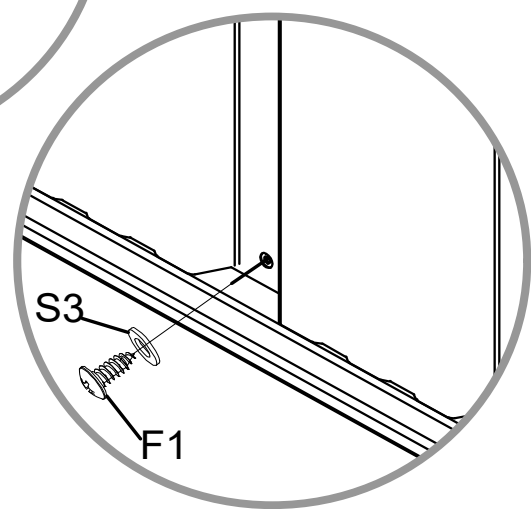

10

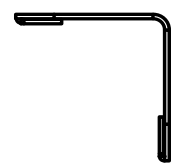

23R (×1)

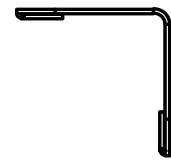

22L (×1)

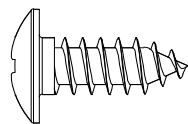

F1 (×11)



S3 (×9)

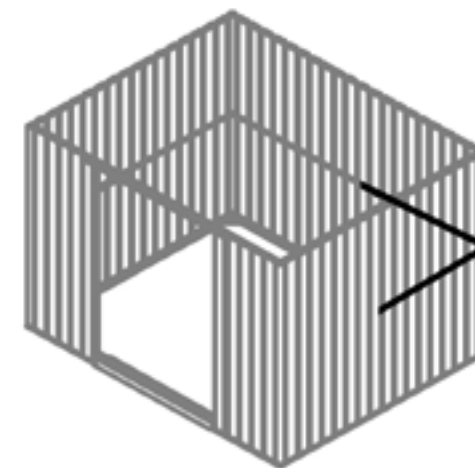

01

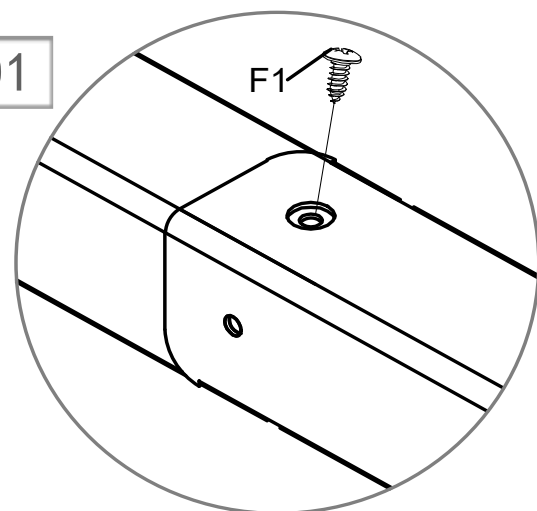

5

22L

23R

02

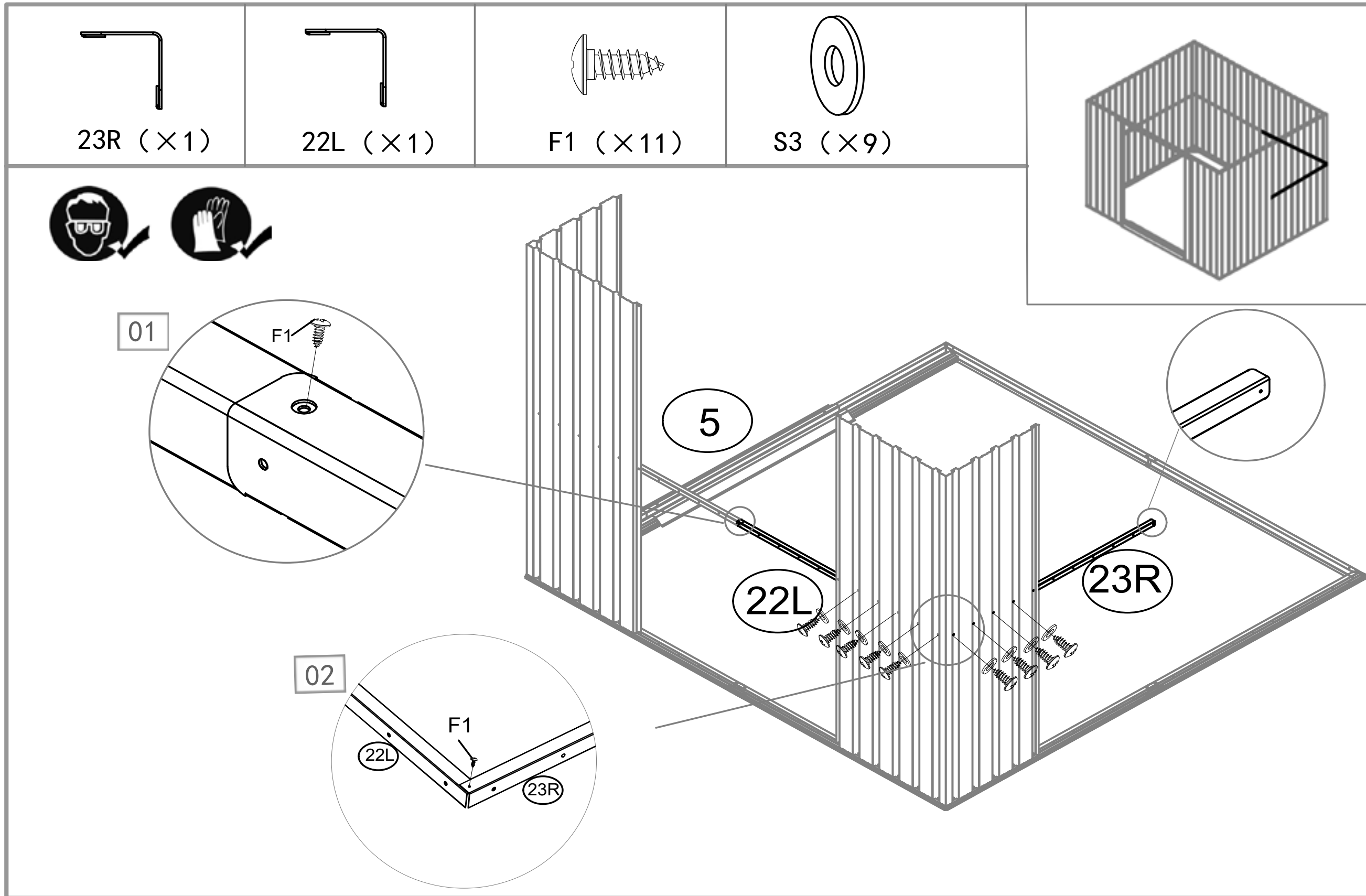
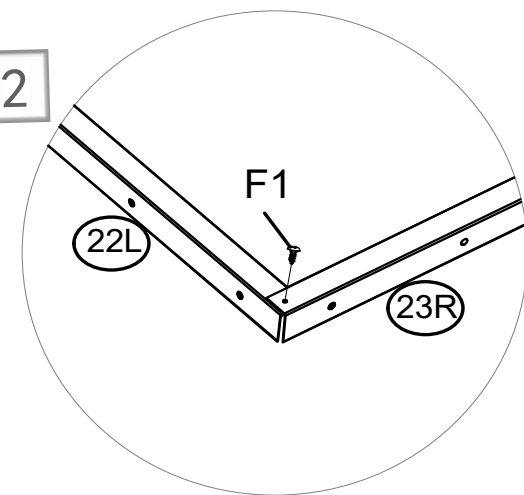

11

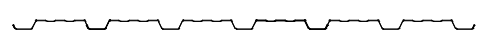
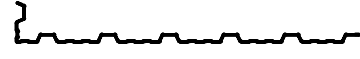
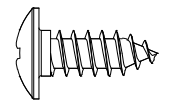
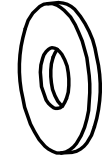
 P3 (×1)	 P4 (×1)	 F1 (×11)	 S3 (×11)
--	---	---	---

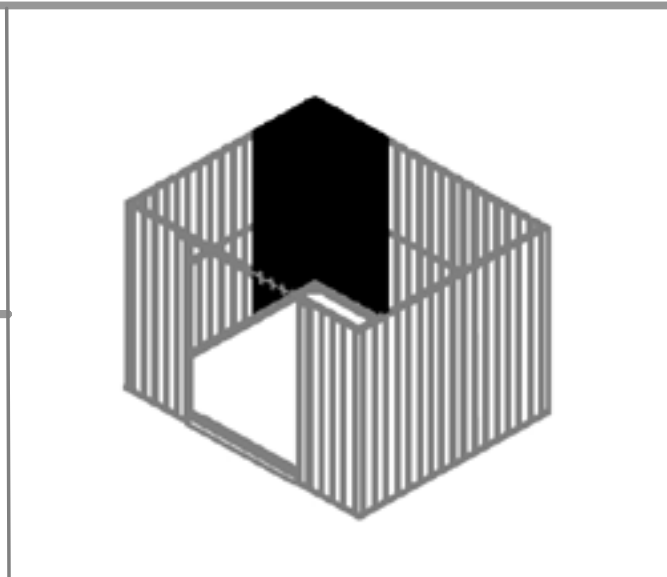

01

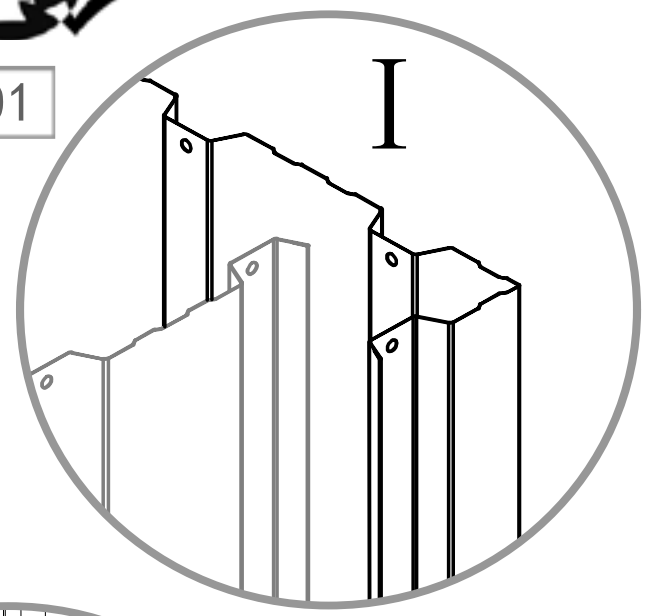

02

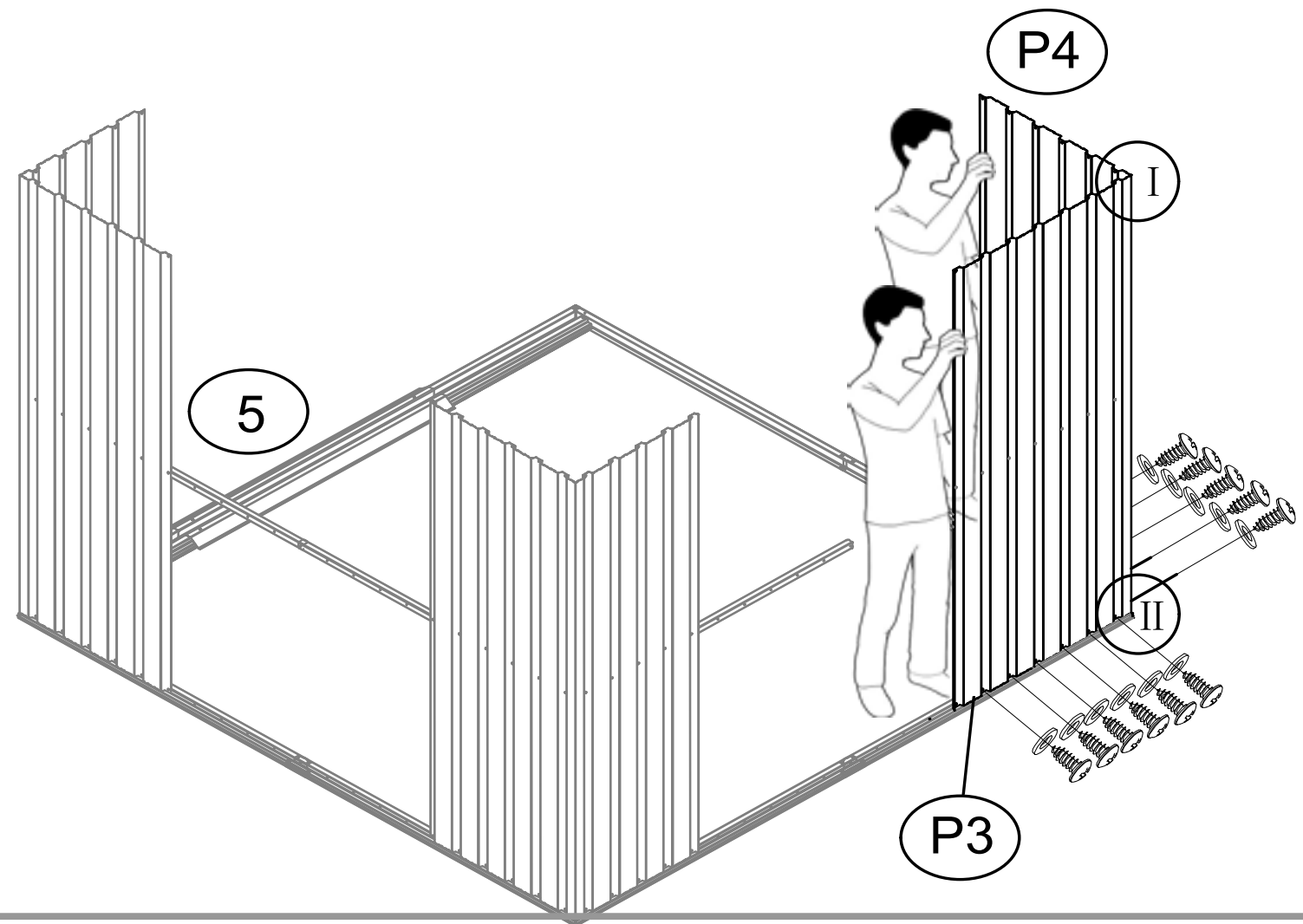
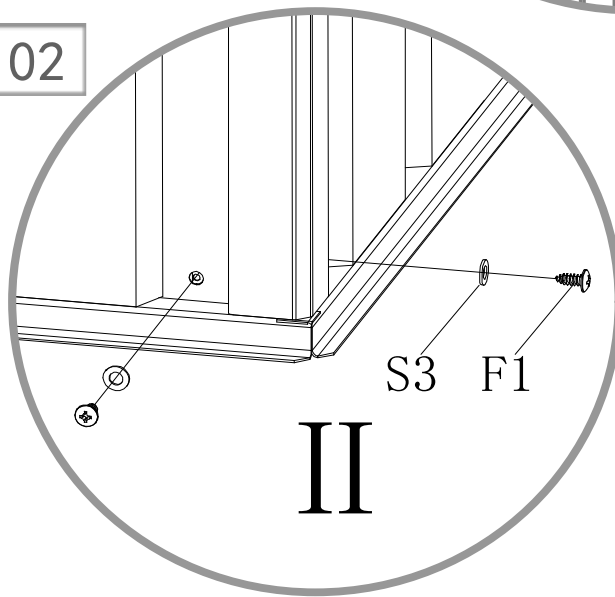

12



23L (×1)



22R (×1)

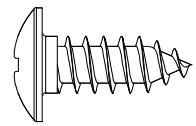



F1 (×13)

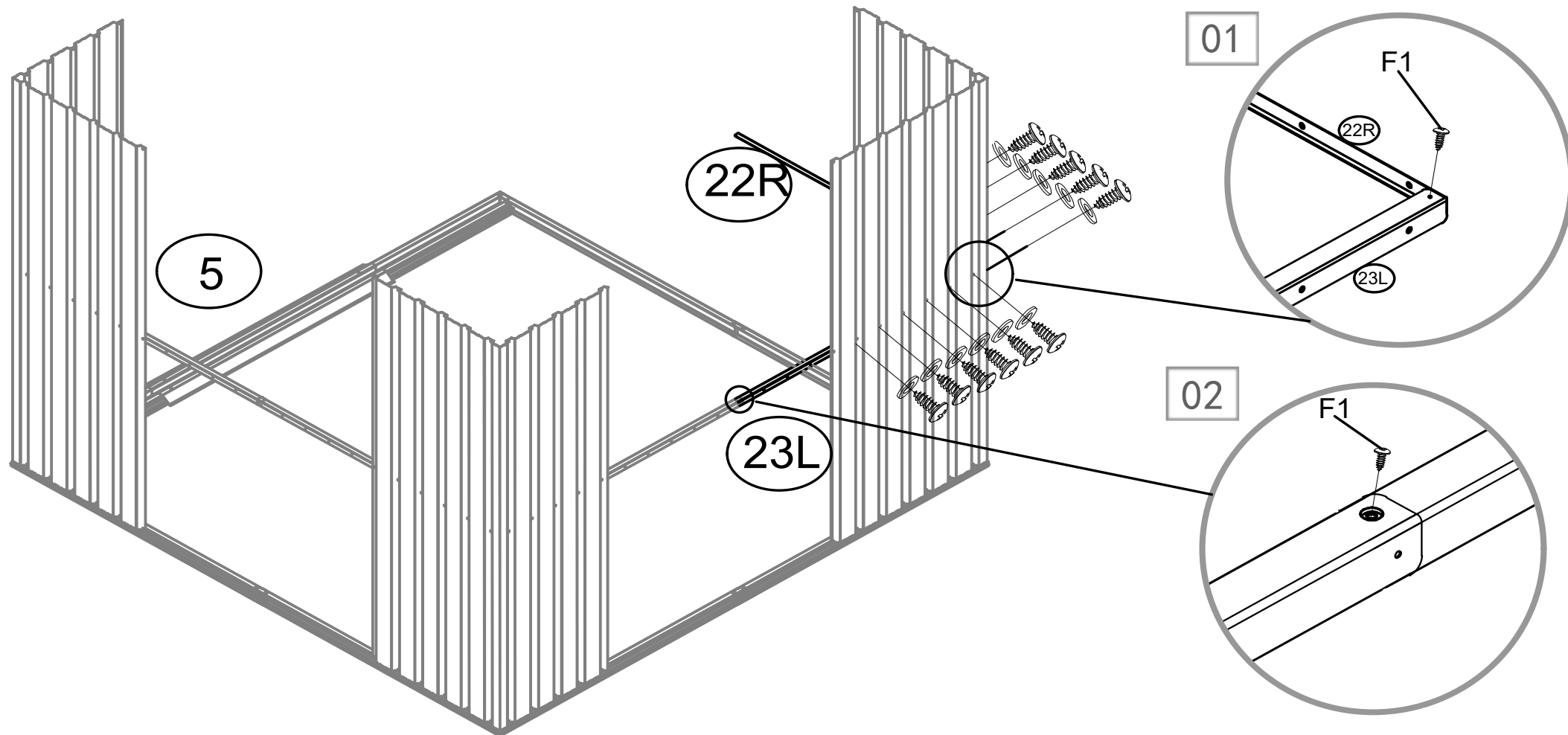
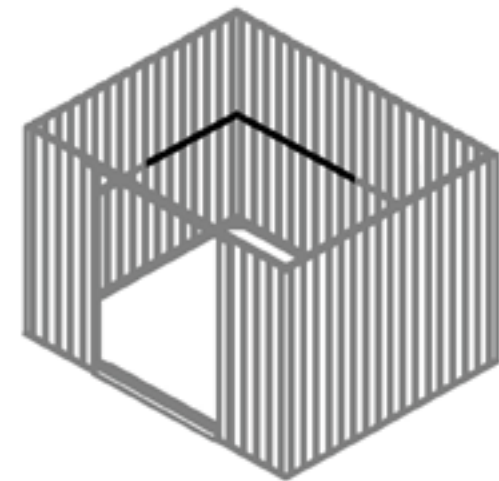

S3 (×11)

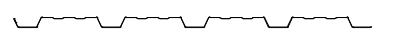

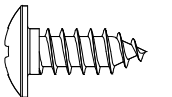
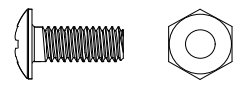
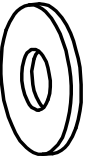
 P1 (×1)	 P4 (×1)	 F1 (×9)	 F2 (×1)	 S3 (×10)
--	---	--	--	---

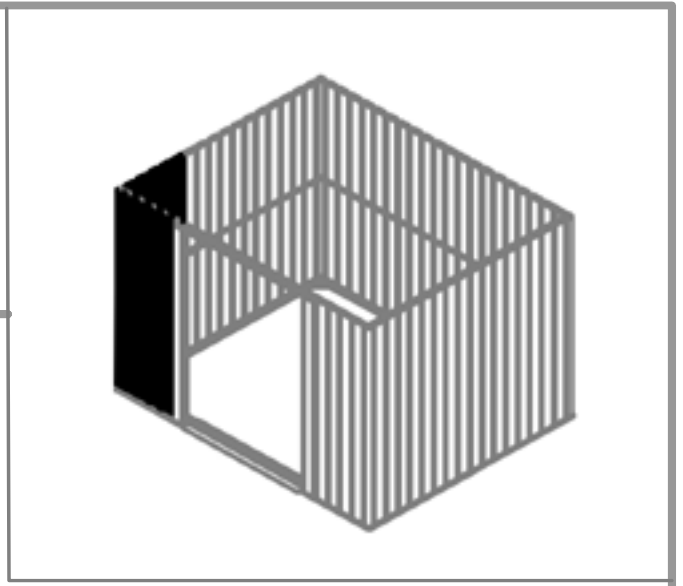

01

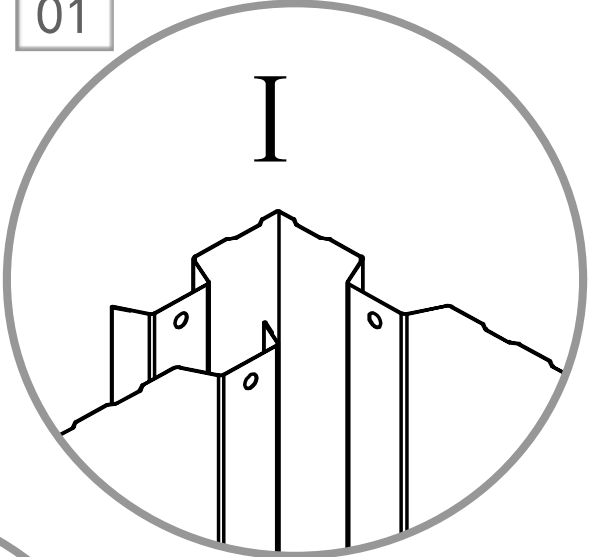

02

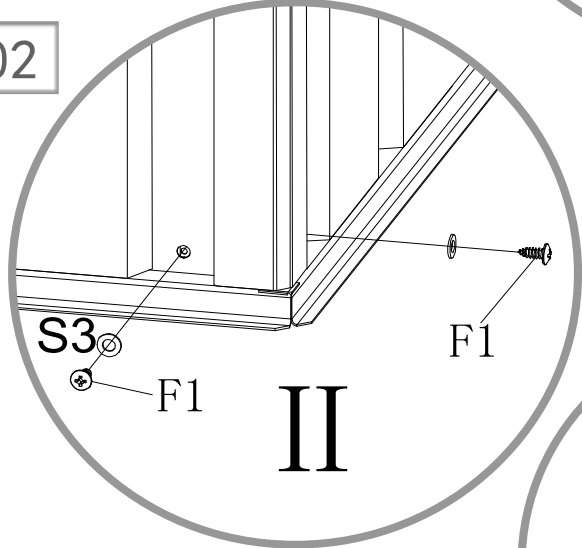

03

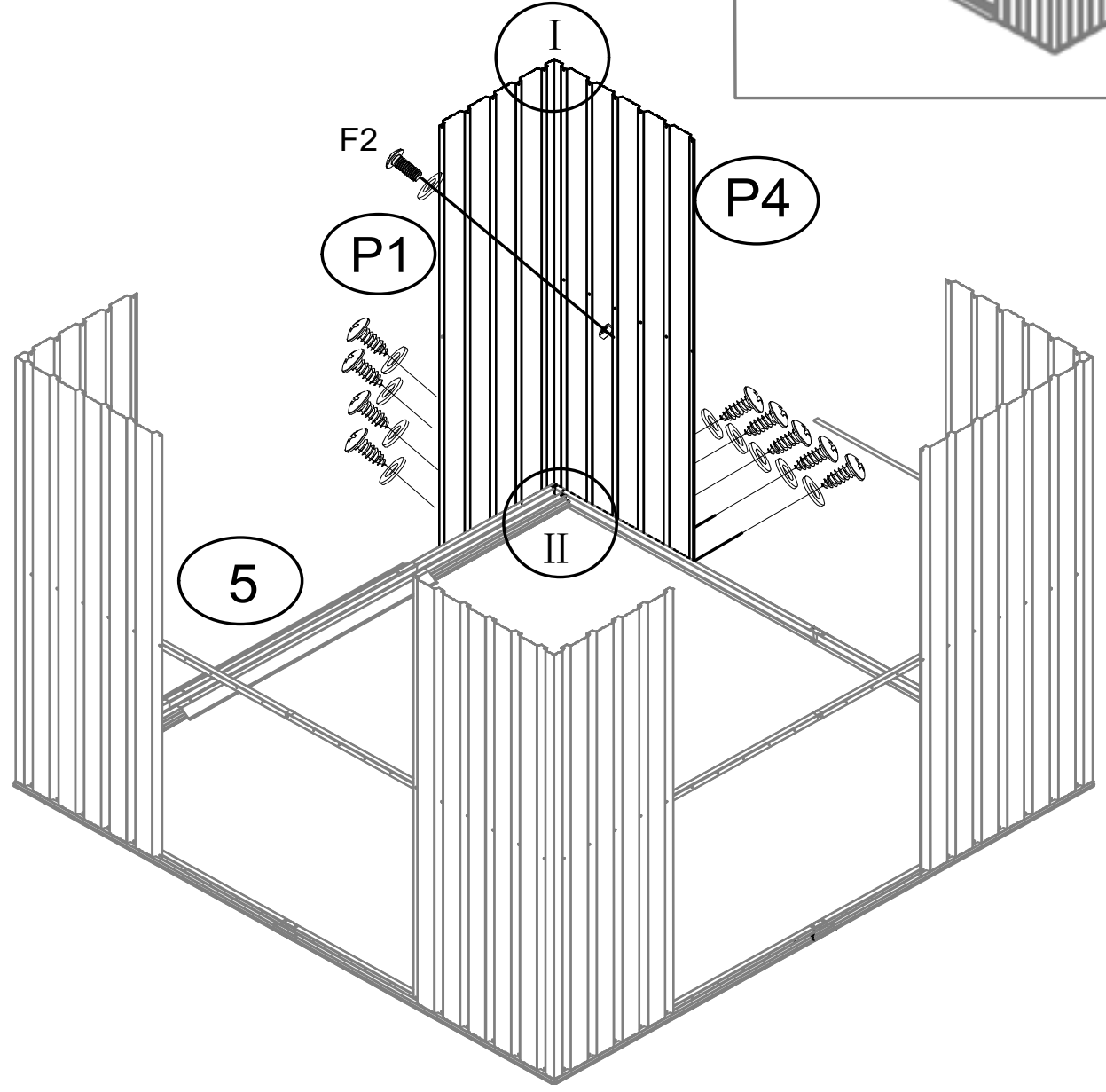
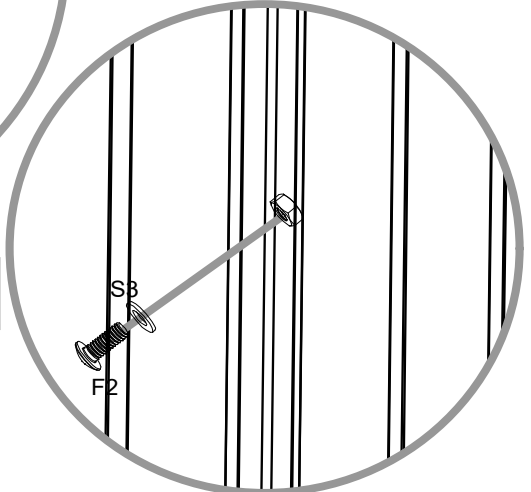

14

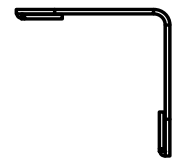

22L (×1)

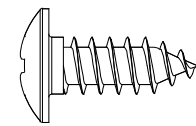

F1 (×6)



S3 (×5)

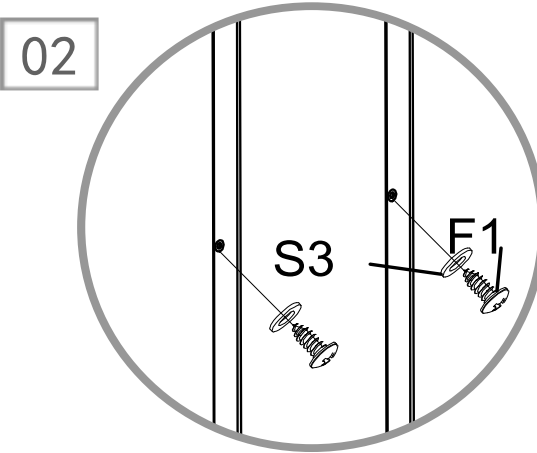
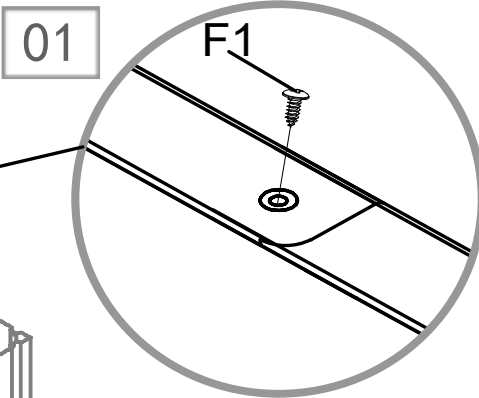
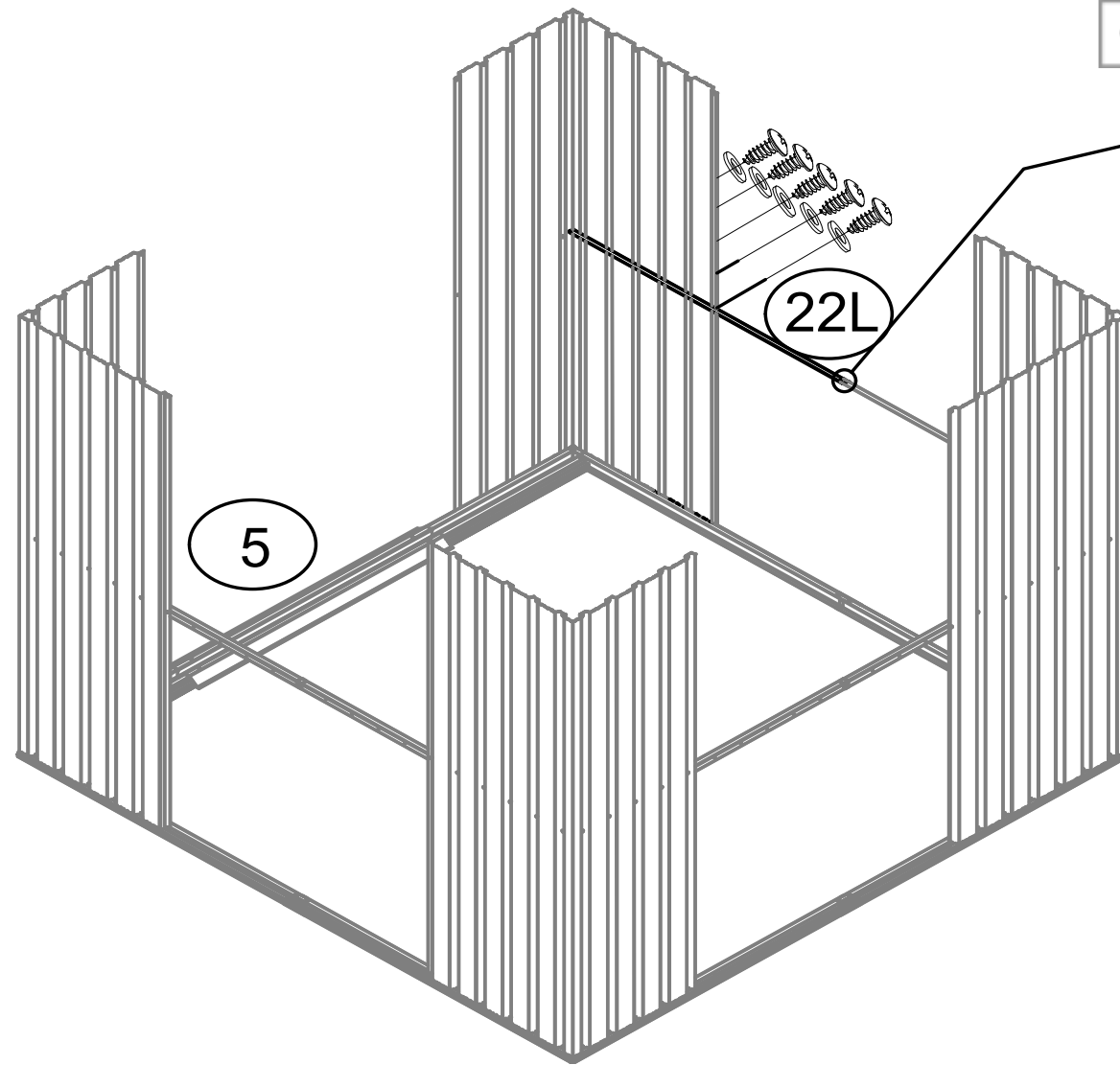
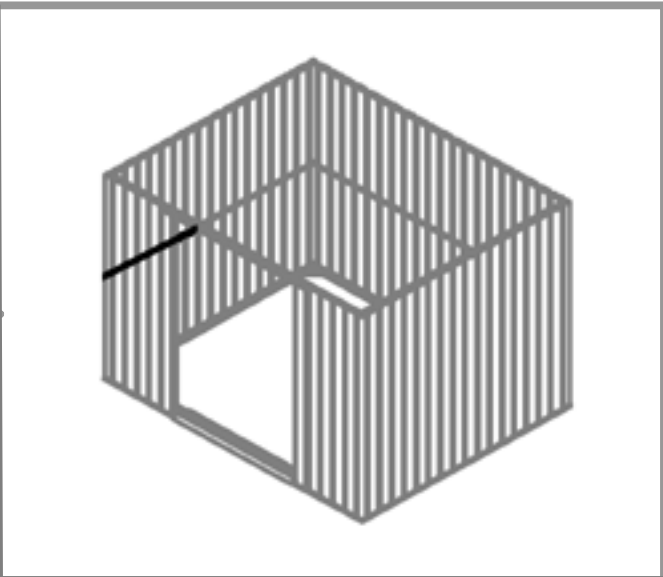



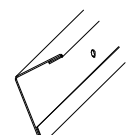
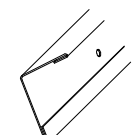
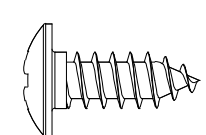
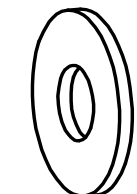

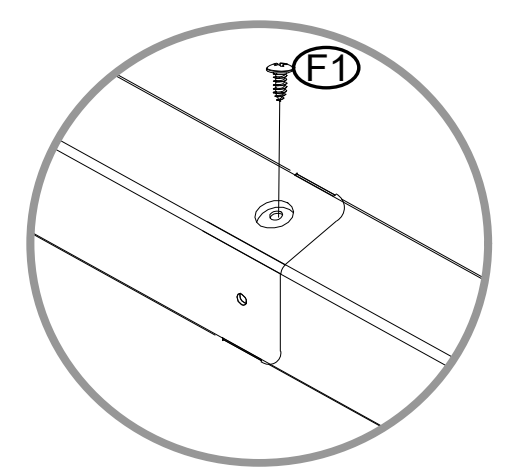
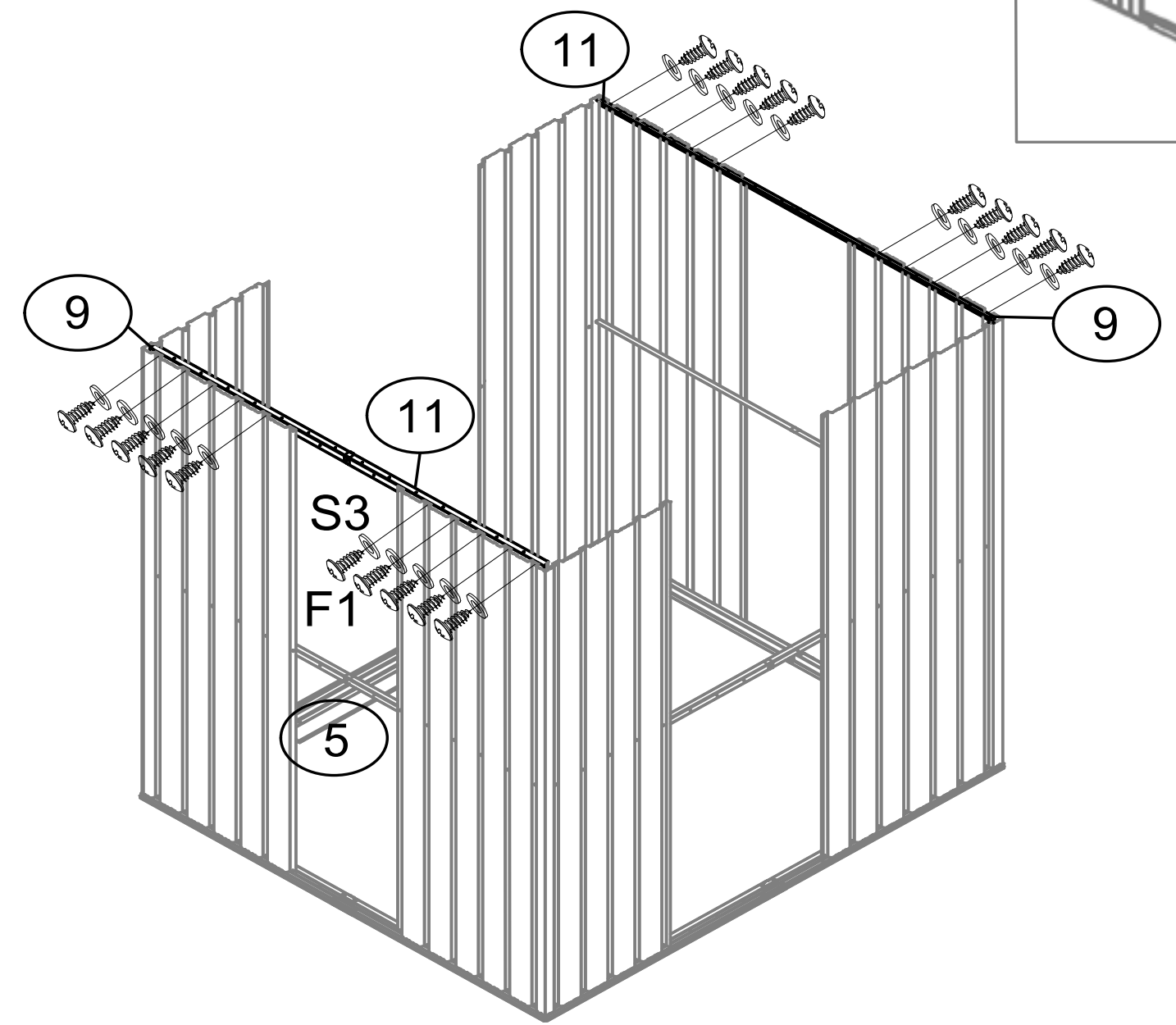
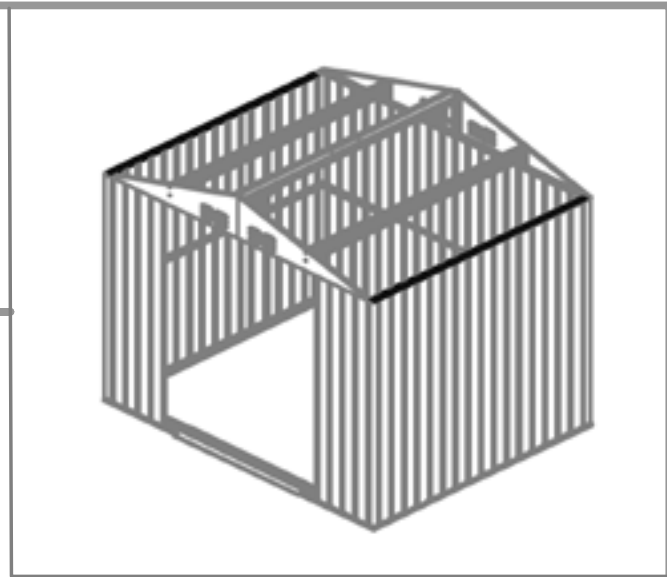
15

-  9 (×2)
-  11 (×2)
-  F1 (×20)
-  S3 (×20)

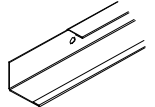
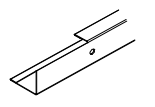
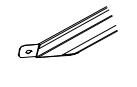

16

 21L (×2)	 21R (×2)	 B3 (×2)	 B4 (×2)	 12 (×2)	 F2 (×12)
---	---	--	--	--	---

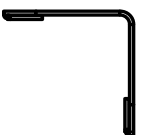
 B1 (×2)	 B2 (×2)
--	--

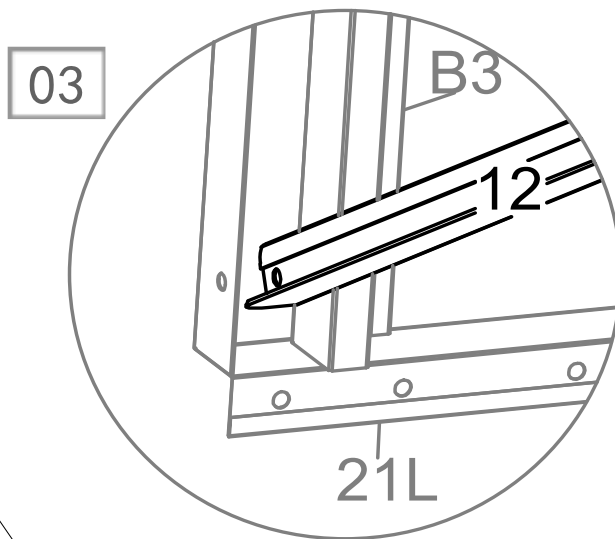
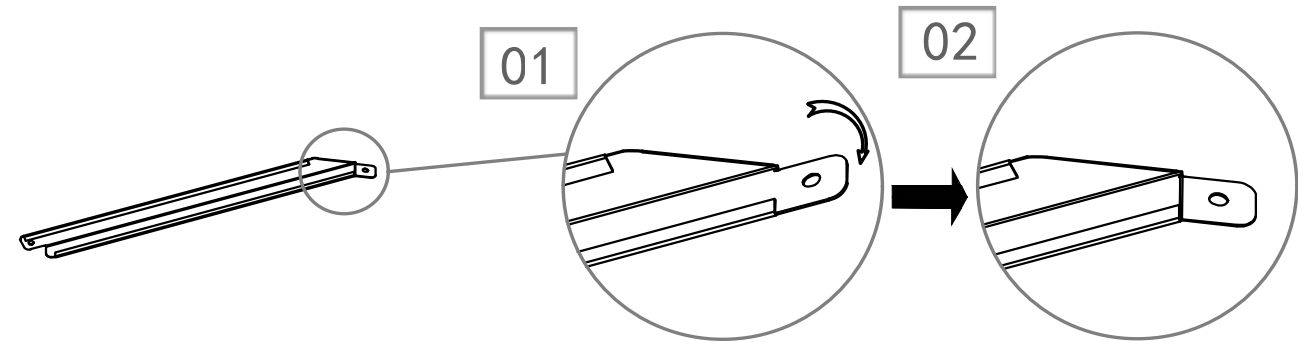
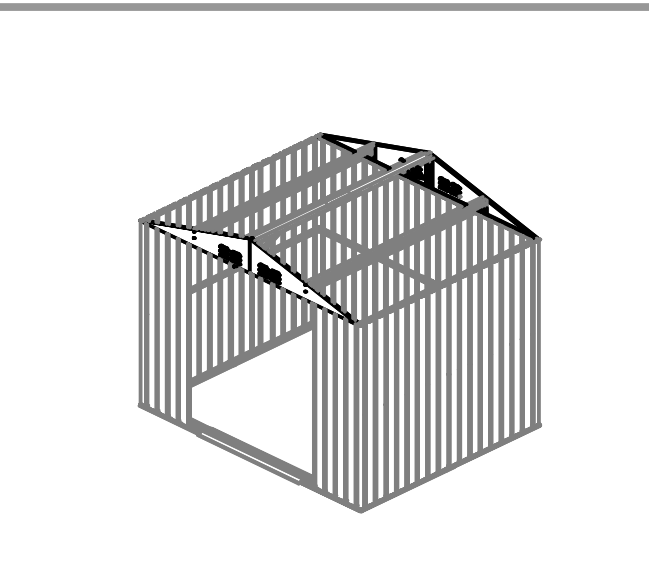
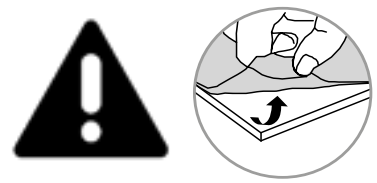

Bent an angle of Part 12 to fit the screw hole of beam

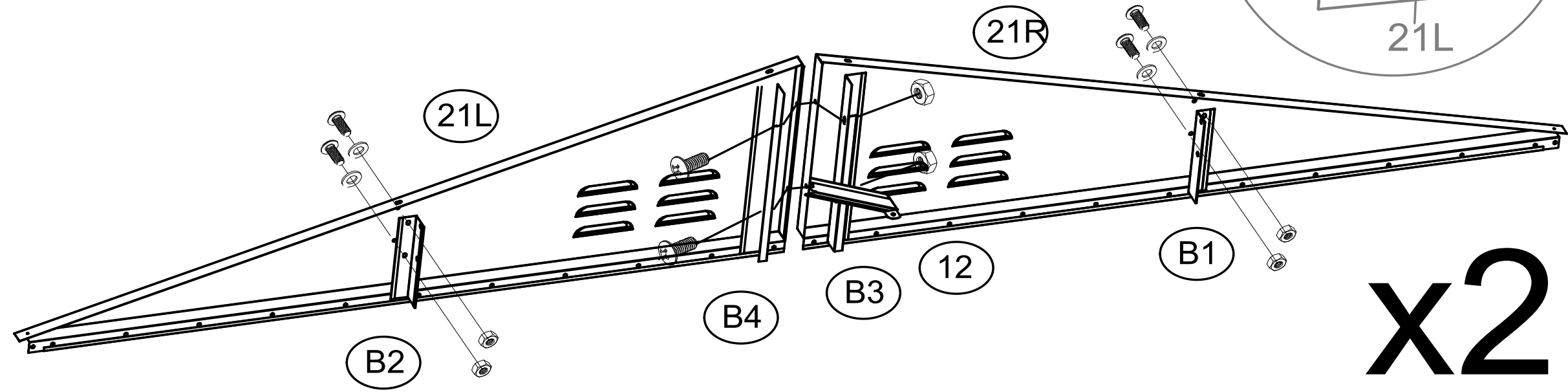

x2

17



10L (×1)



10R (×1)

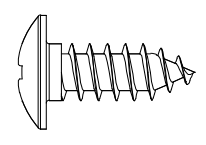

F1 (×10)

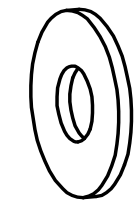

S3 (×10)

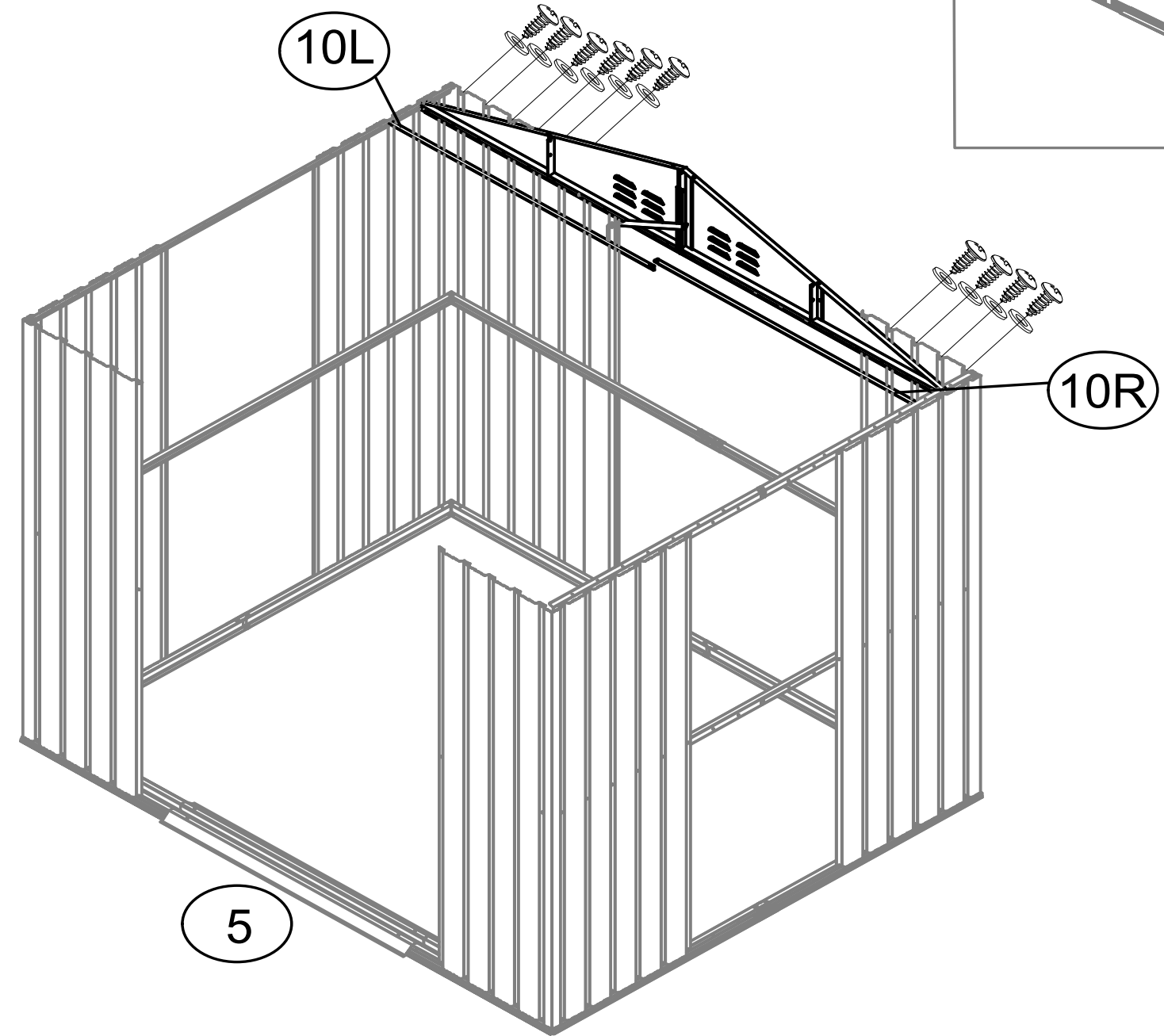
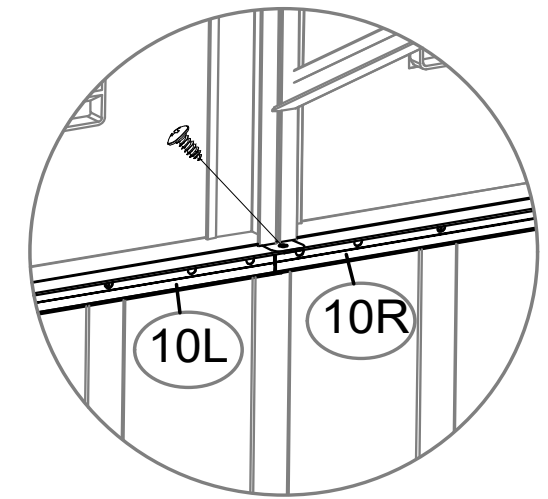
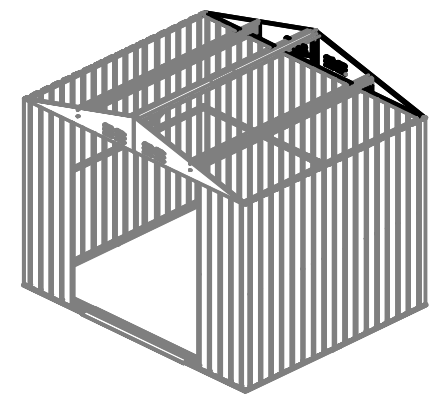

18



7 (×1)



8 (×1)

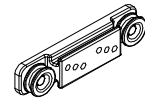

G2 (×4)

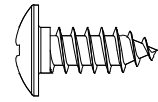

F1 (×8)



S3 (×8)

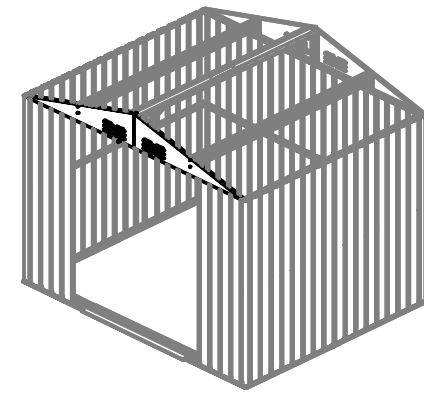

01

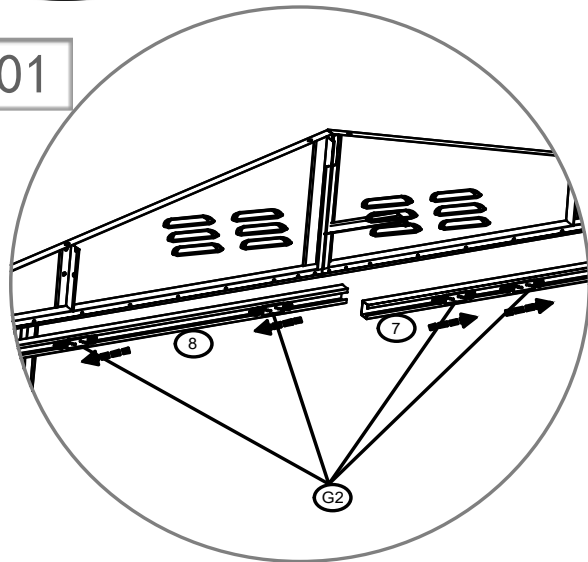

02

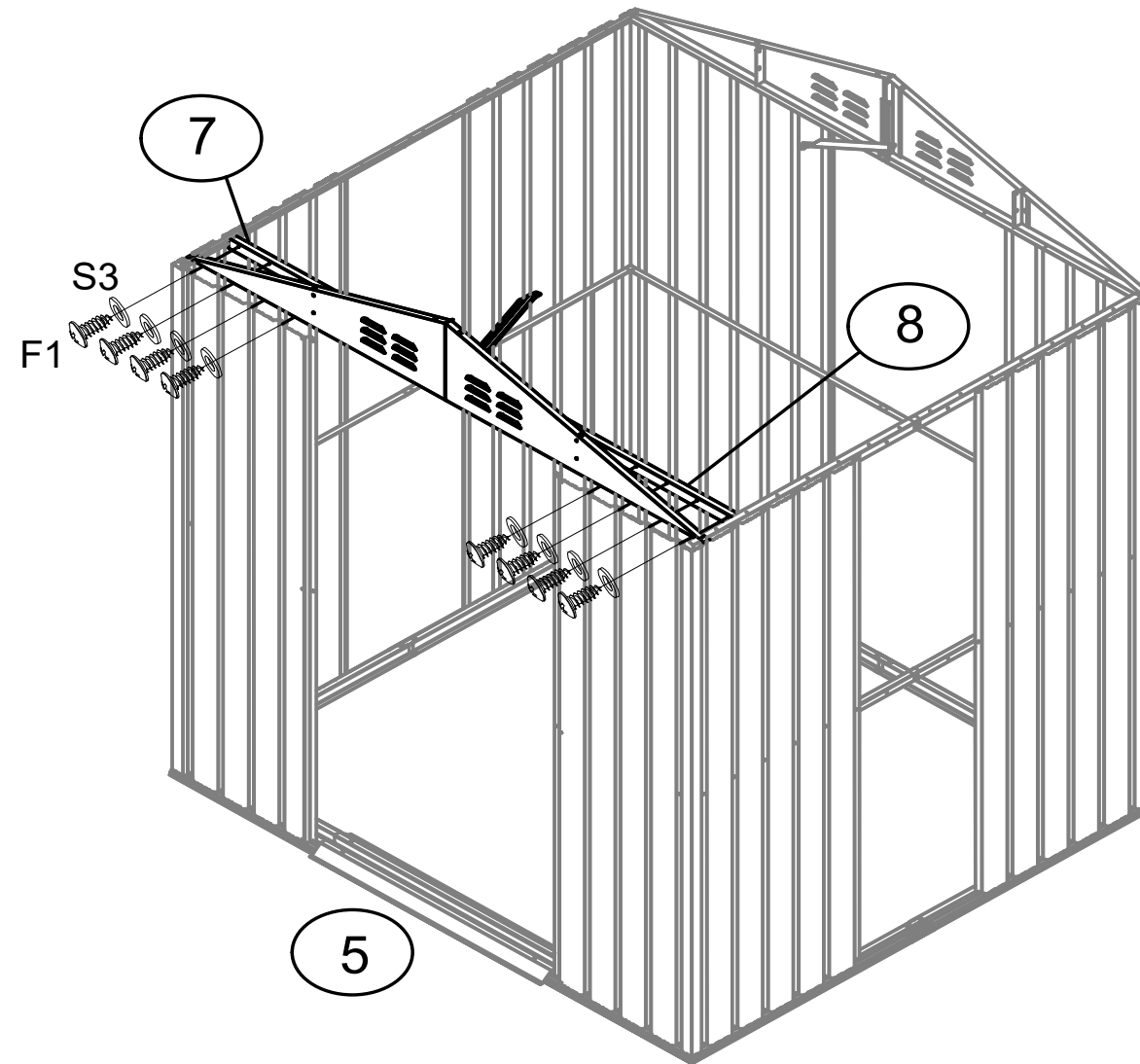
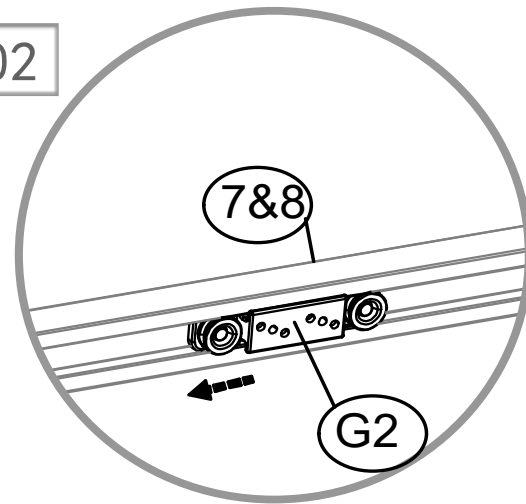

19

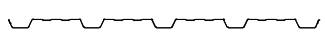

P2 (×1)

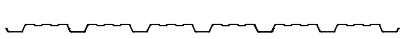

P3 (×3)

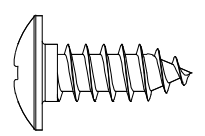

F1 (×75)

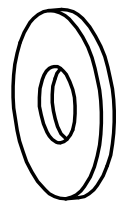

S3 (×75)

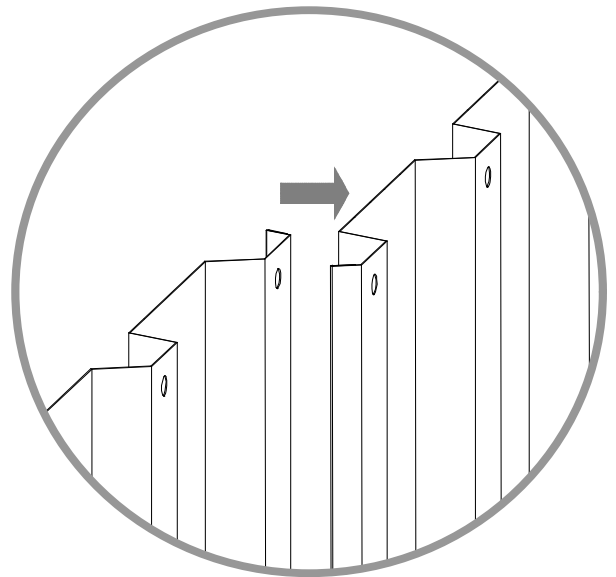
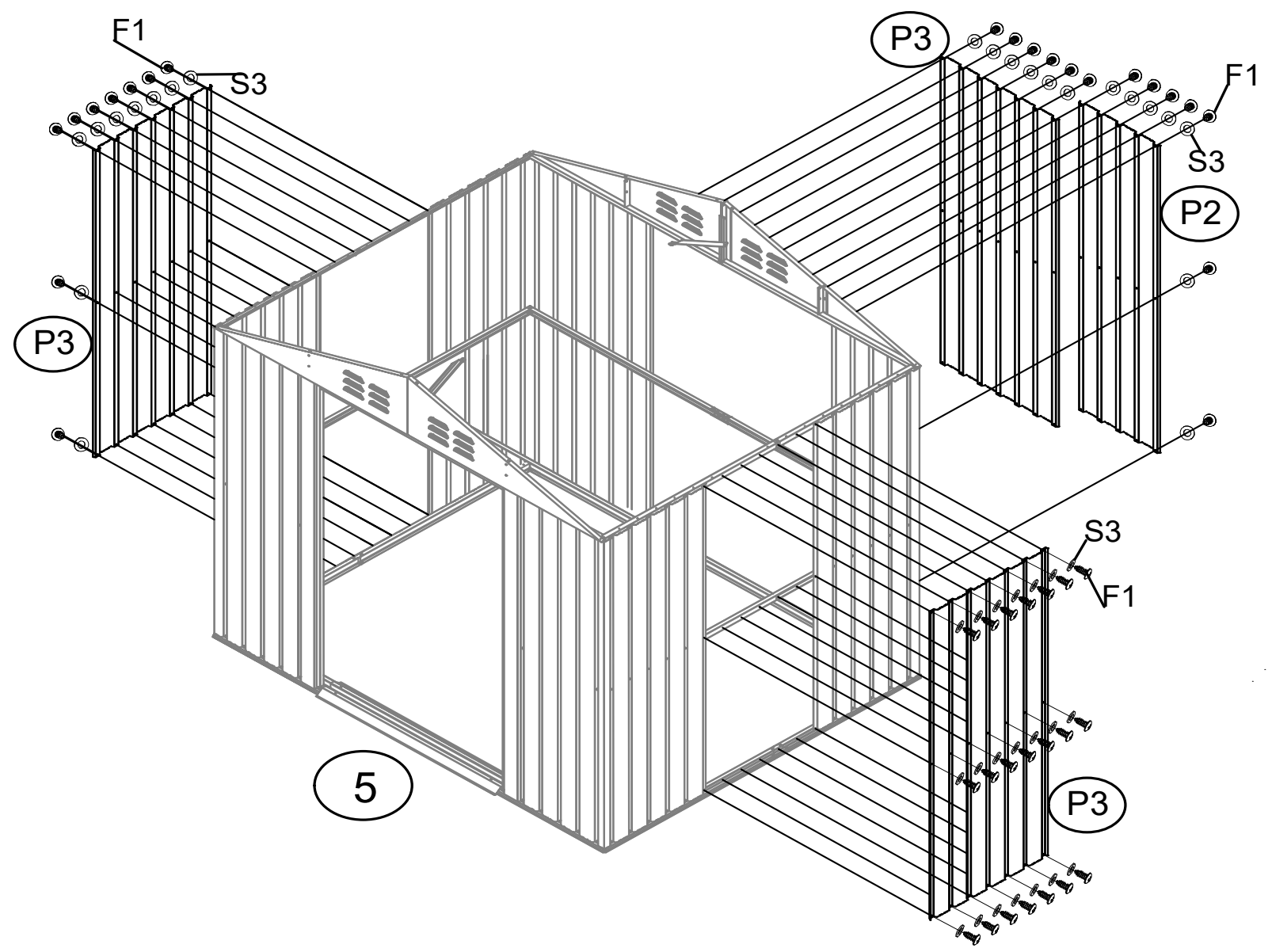
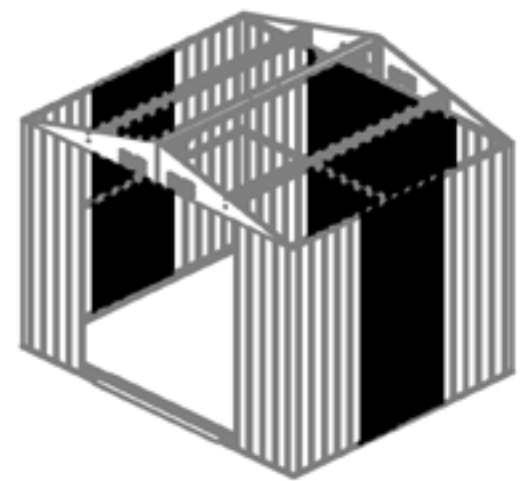

20

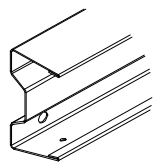

13 (×2)

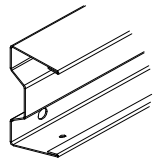

14 (×2)



F2 (×8)

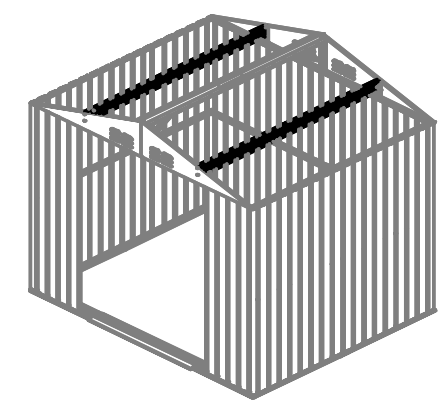

01

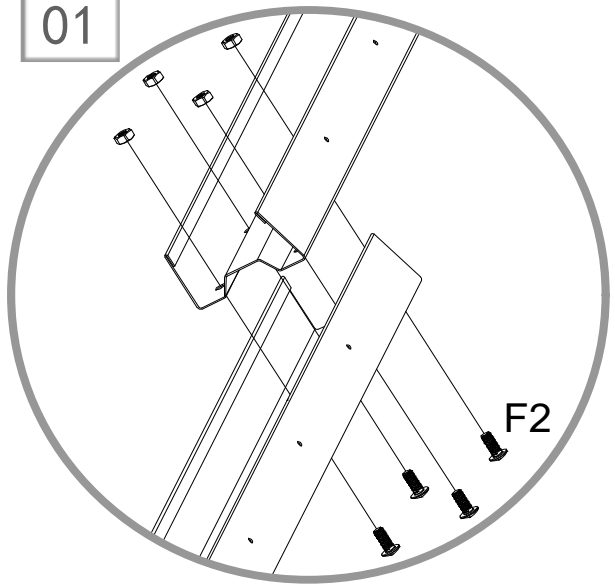

02

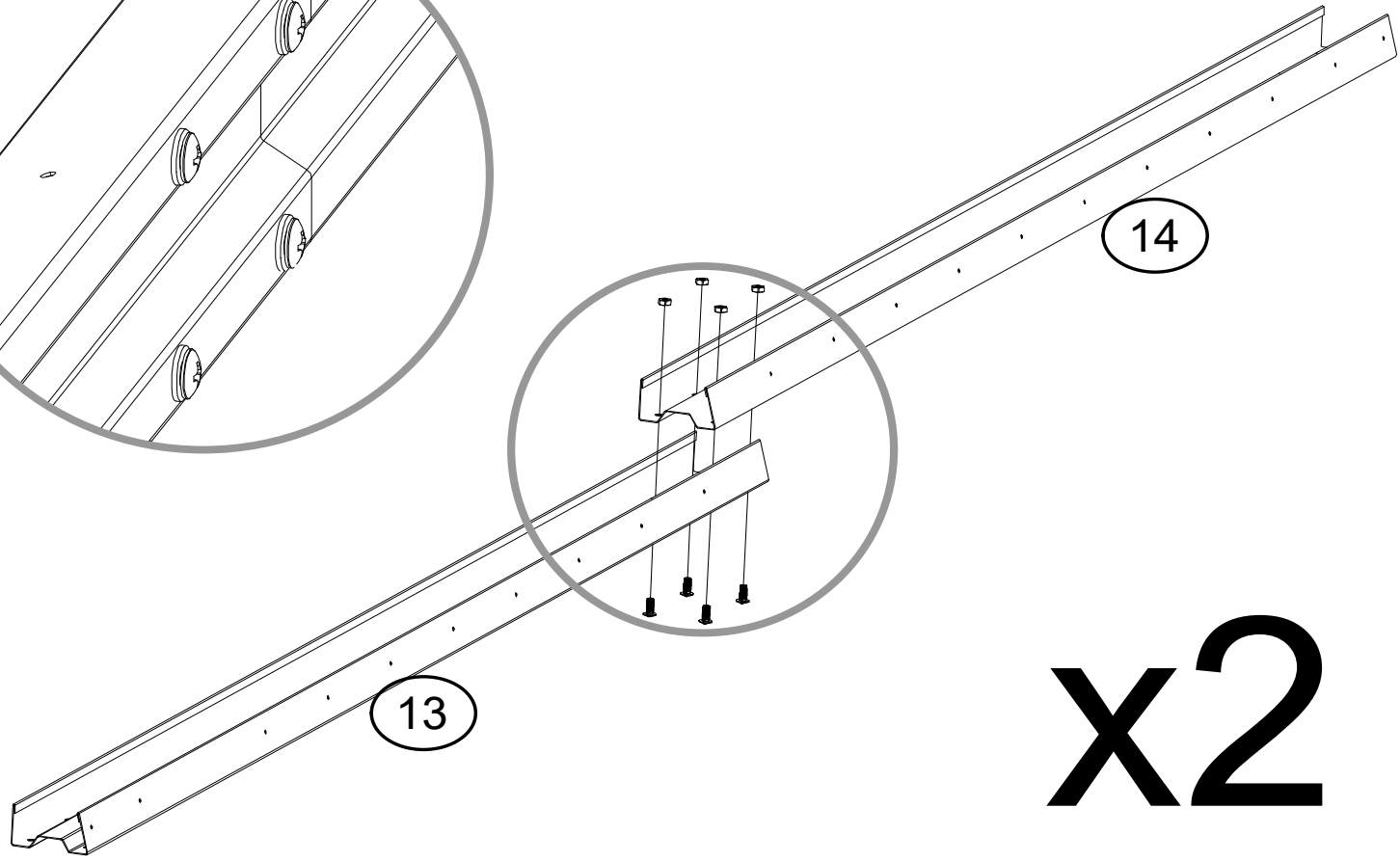
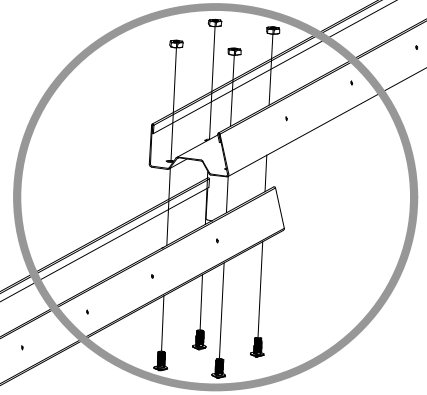
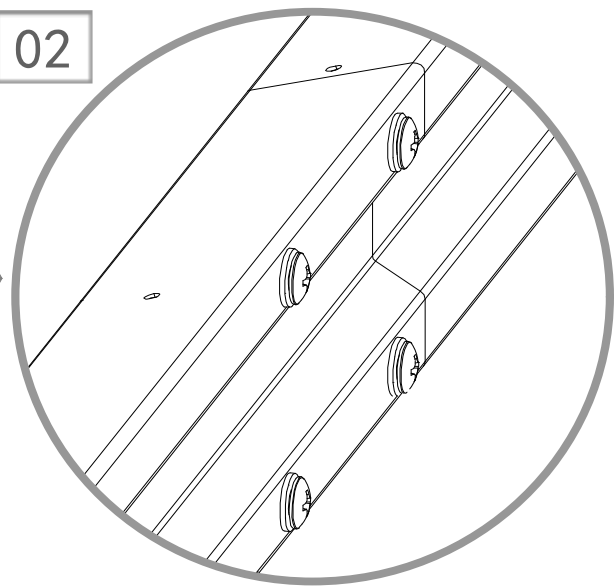

14

13

x2

21

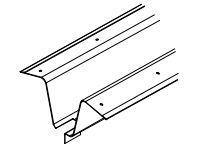

16 (×1)

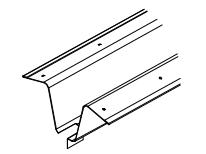

16-1 (×1)

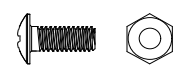

F2 (×2)

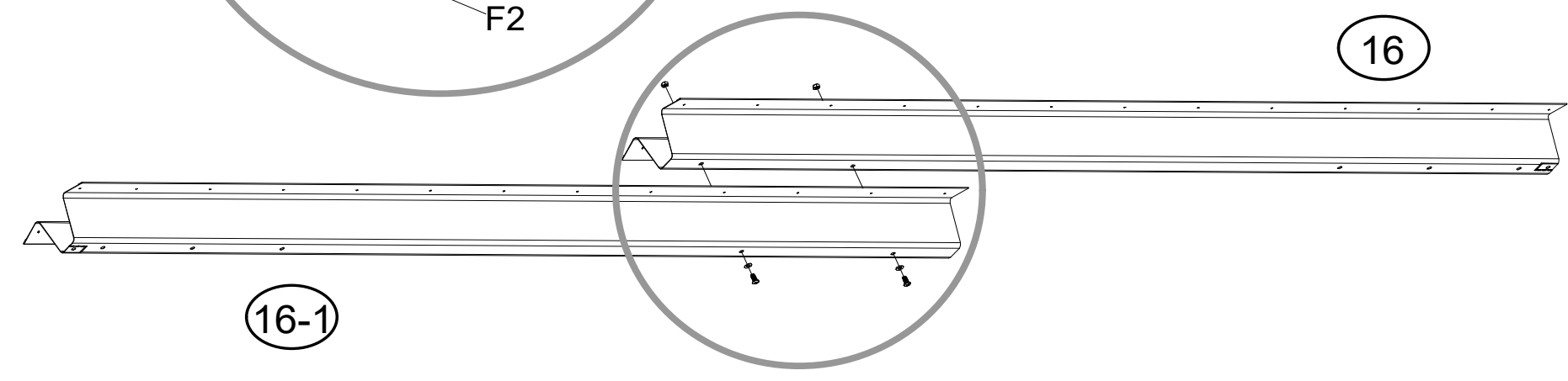
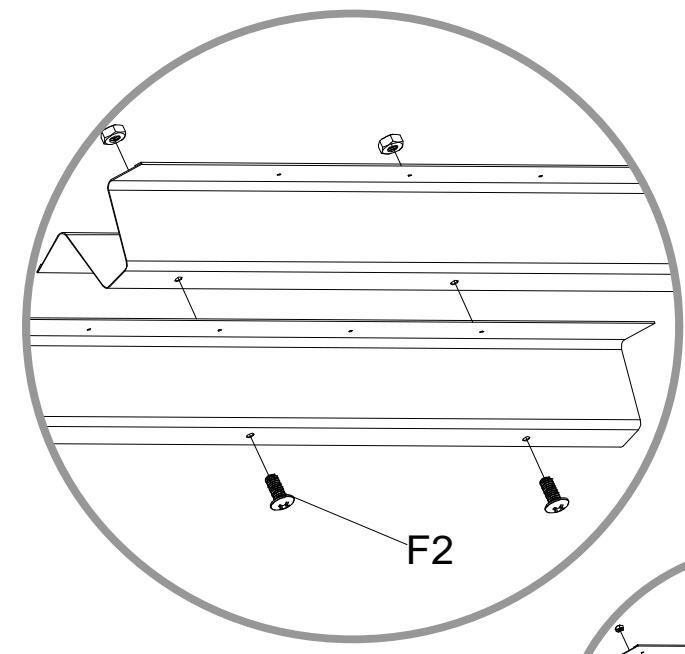
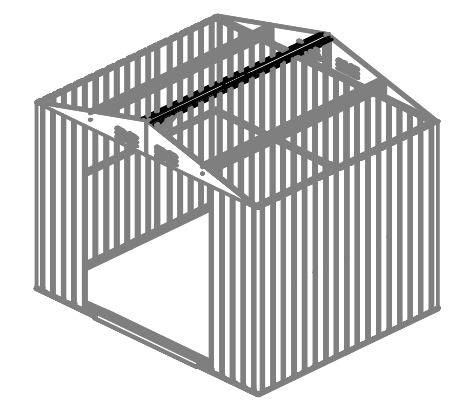

16-1

16



F2 (×2)

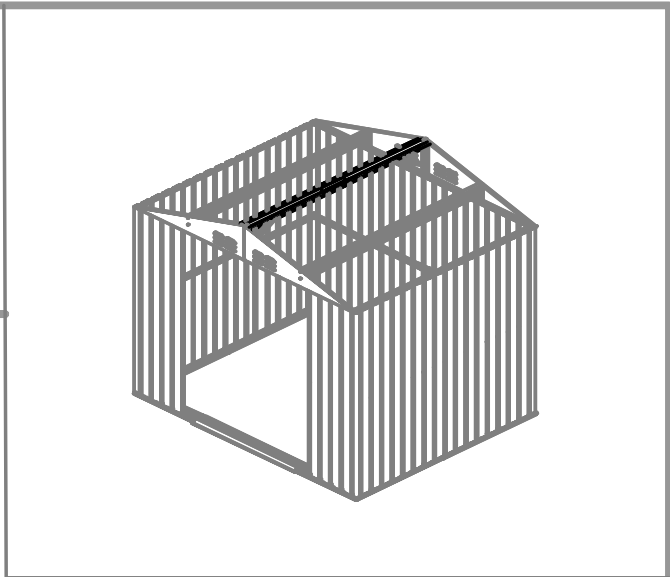

01

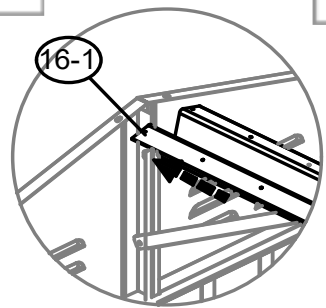

02

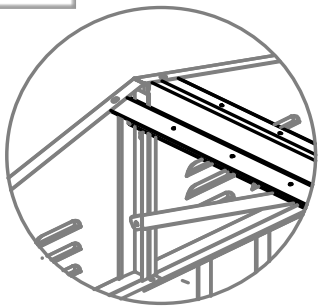

03

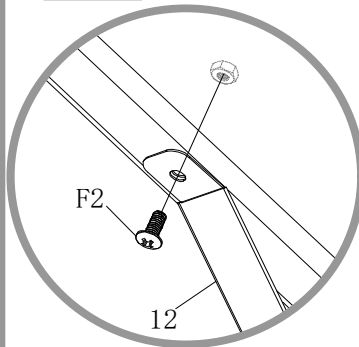

04

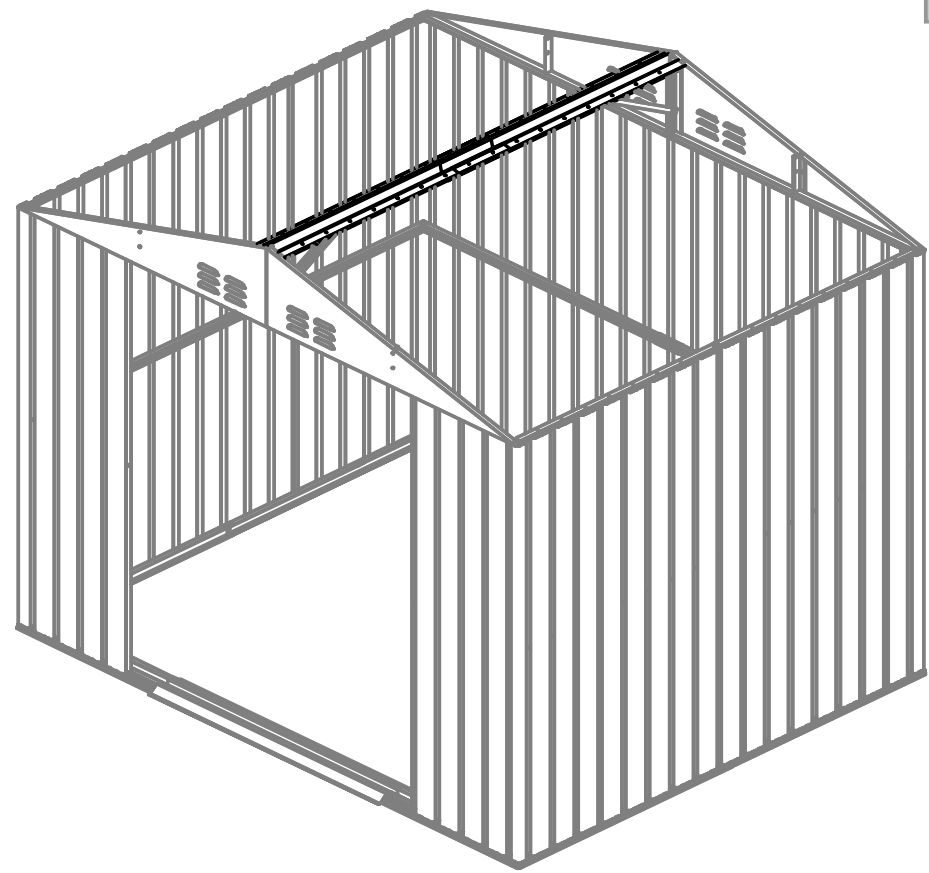
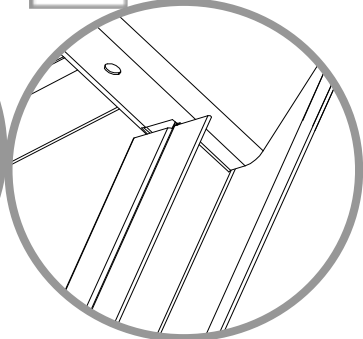

05

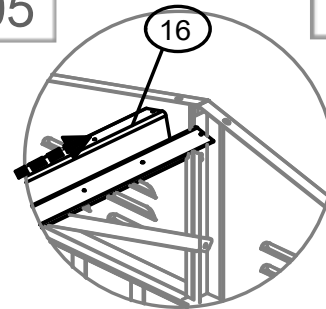

06

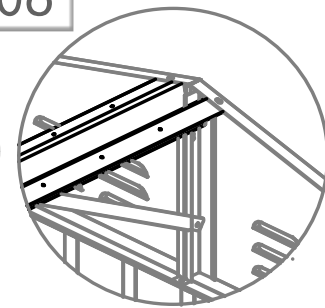

07

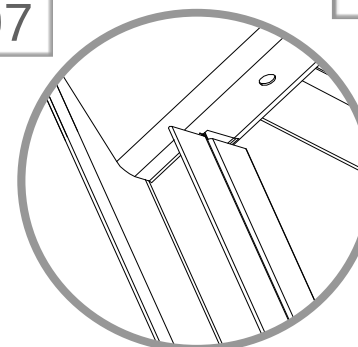



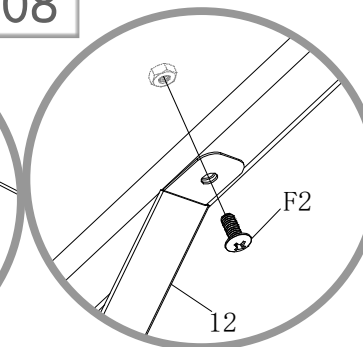

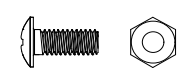
08



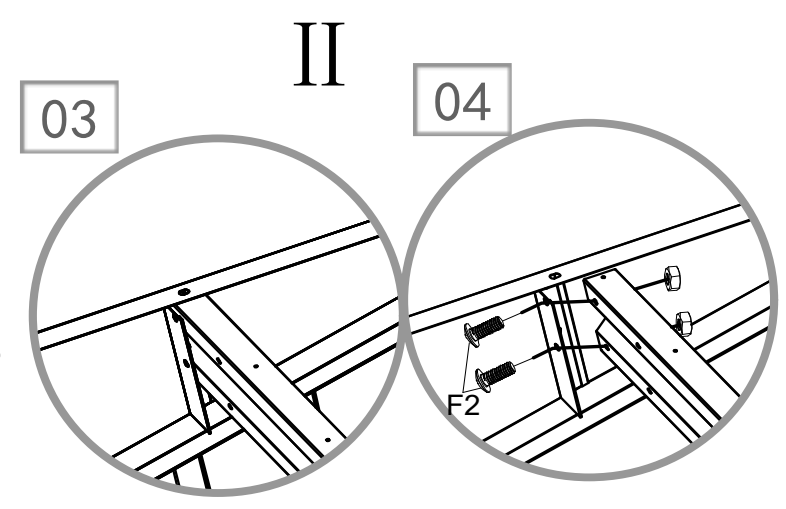
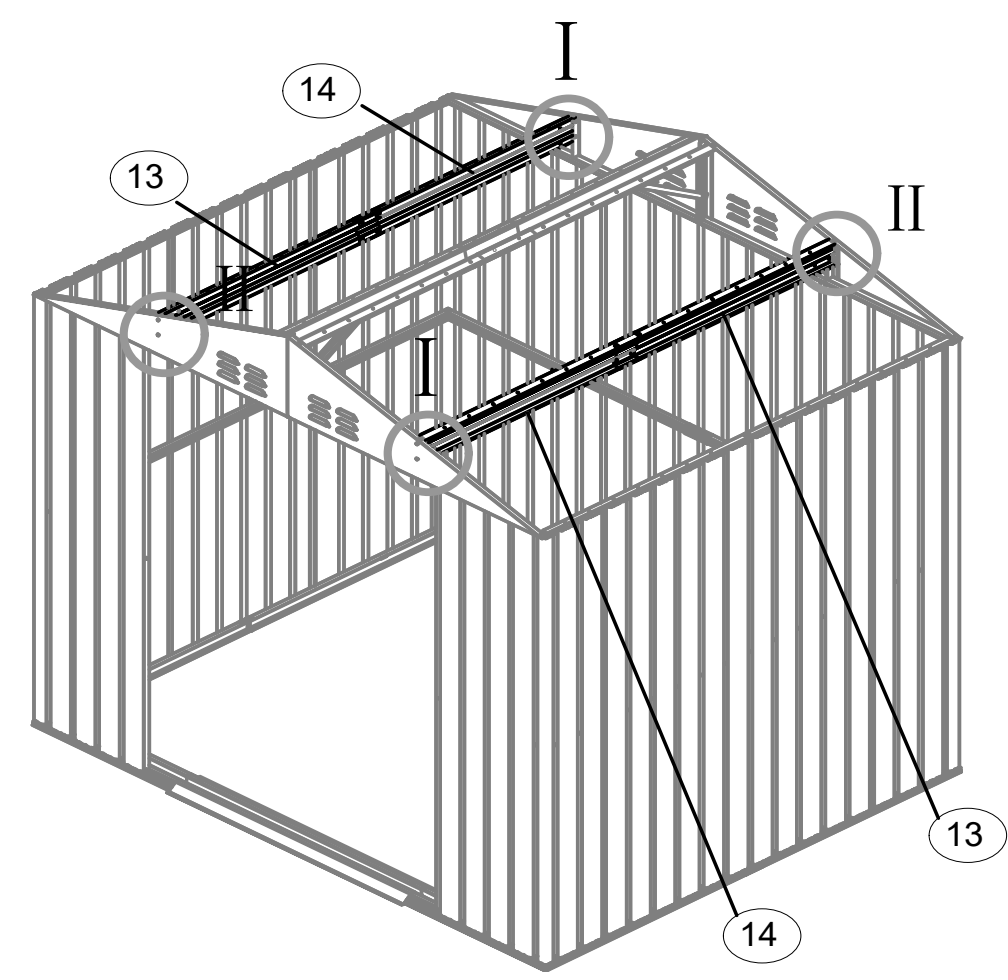
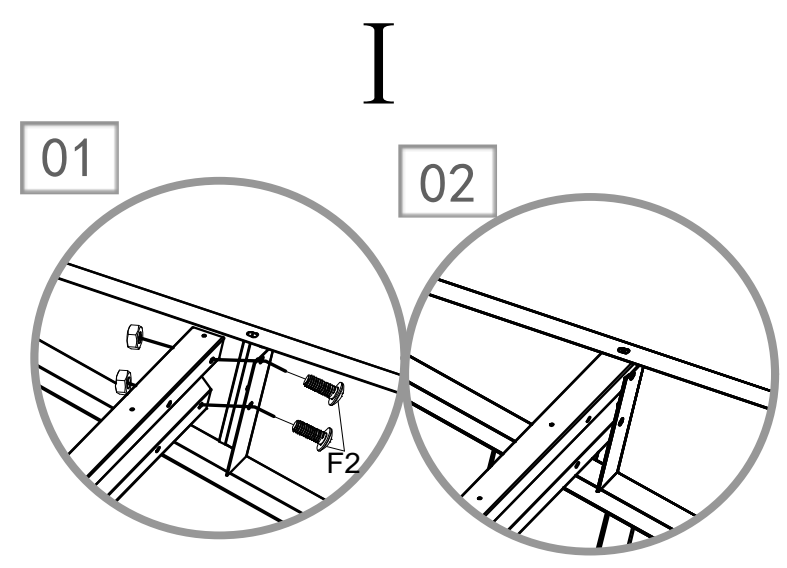
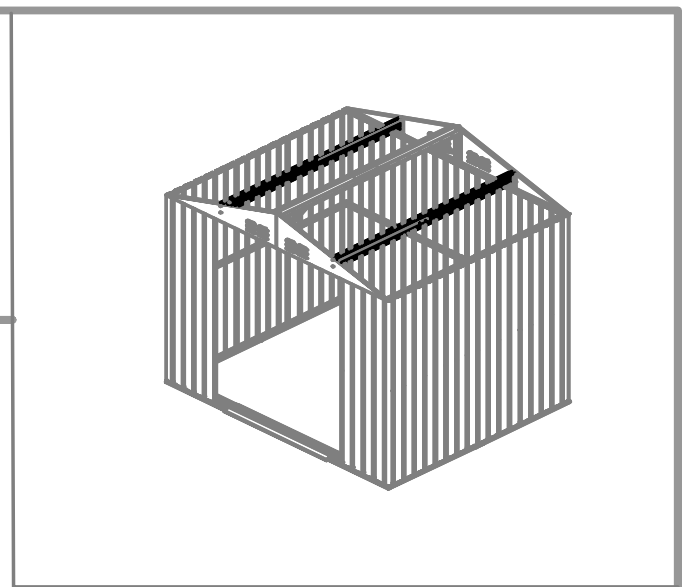

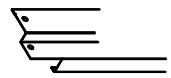
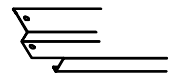
F2 (×8)

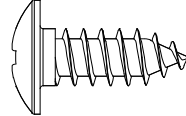

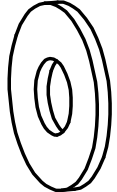
					
4L (×1)	4R (×1)	6 (×1)	F1 (×8)	F2 (×2)	S3 (×10)

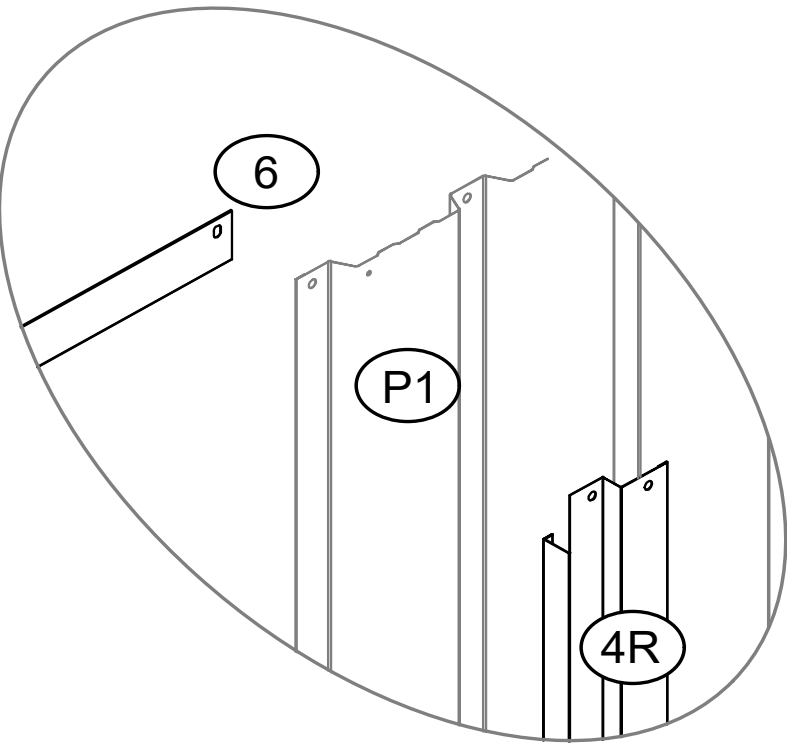
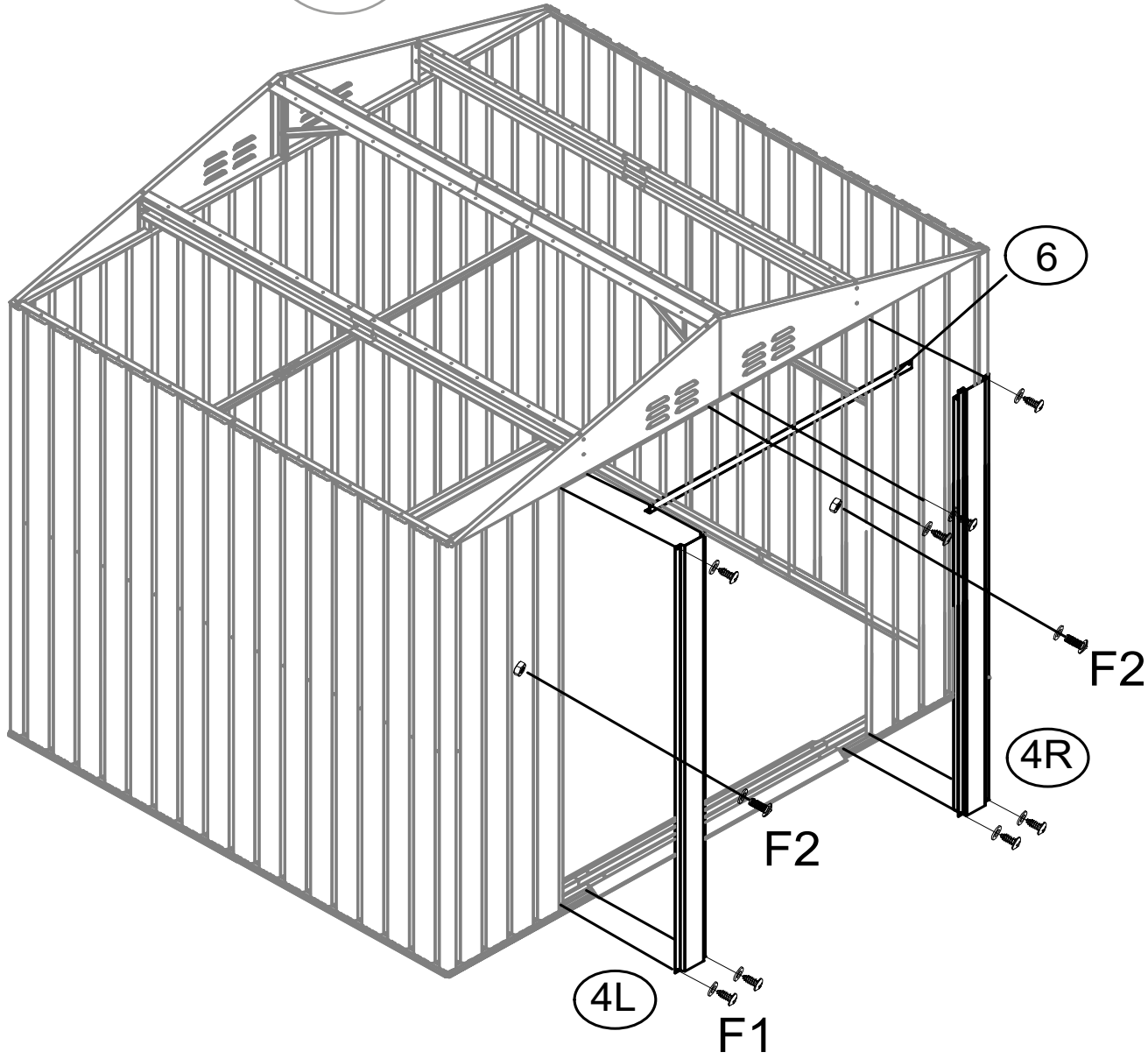
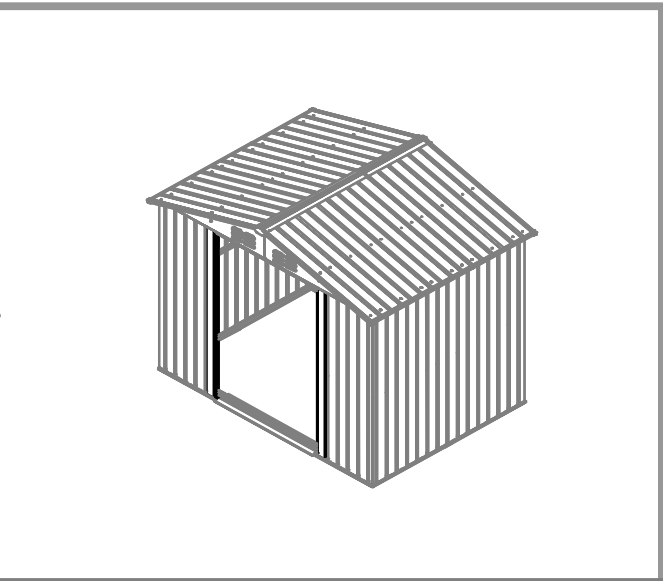

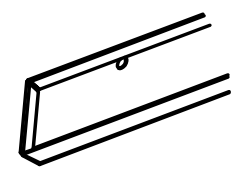

6-1 (×1)

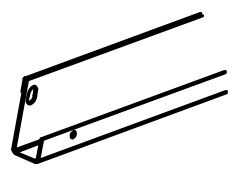

6-2 (×1)

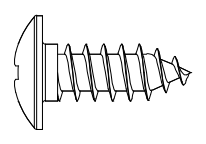

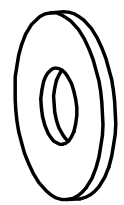

F1 (×6)

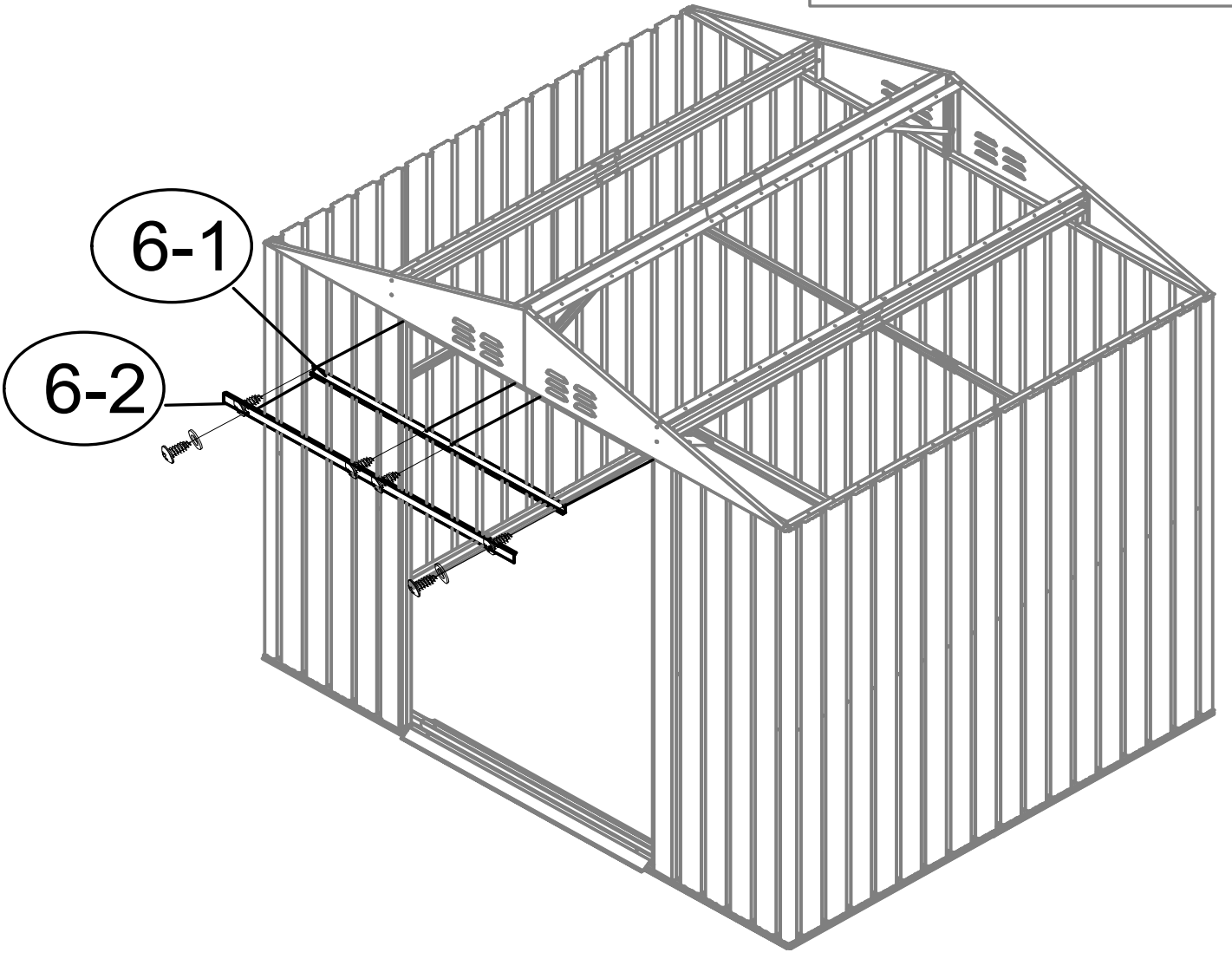
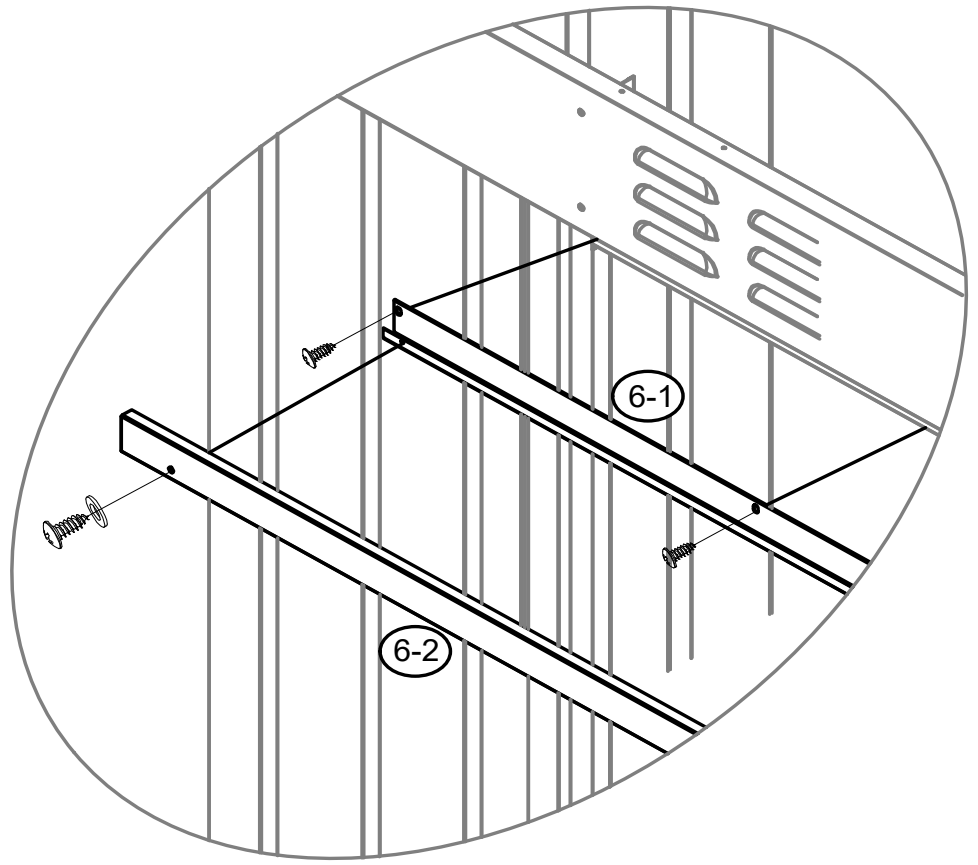
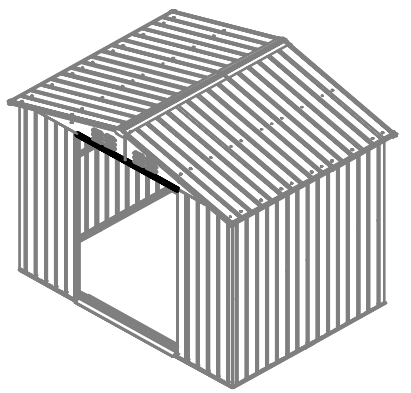

S3 (×2)

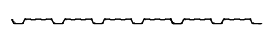
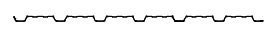
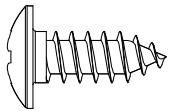

 P5 (×1)	 P6 (×1)	 F1 (×24)	 S3 (×24)
--	---	---	---

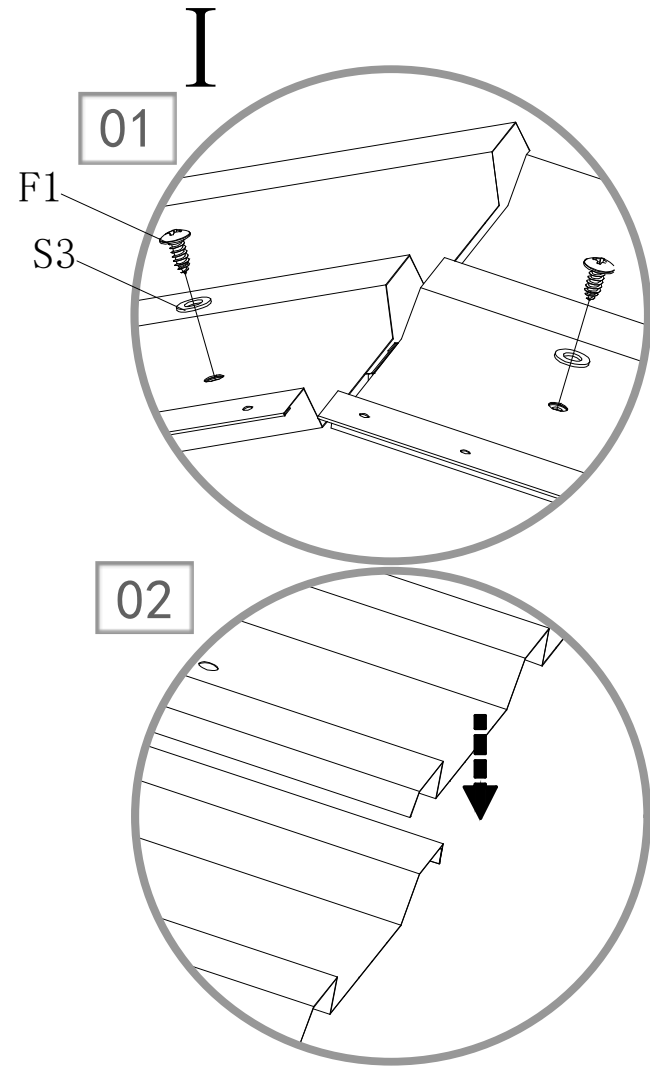
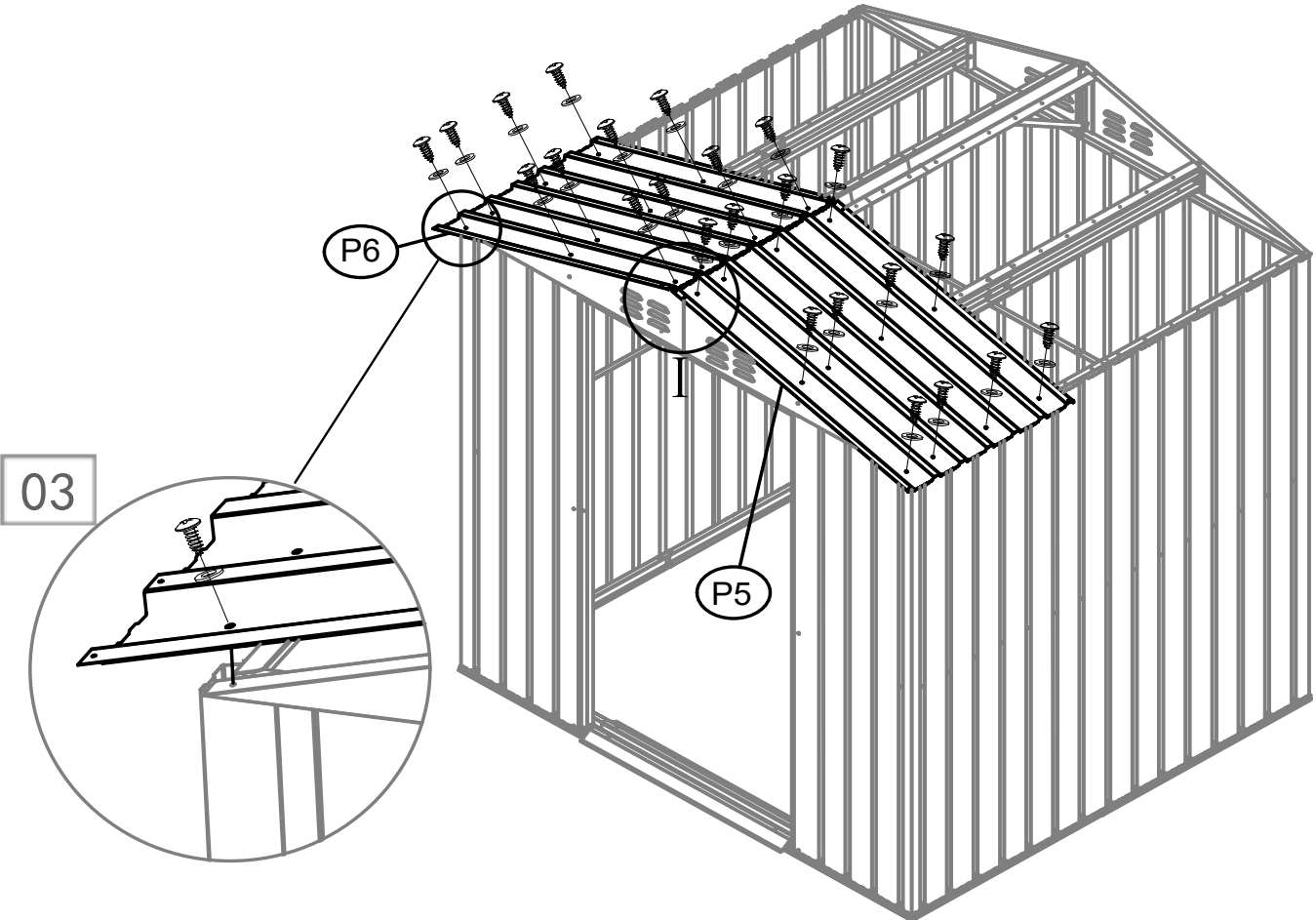
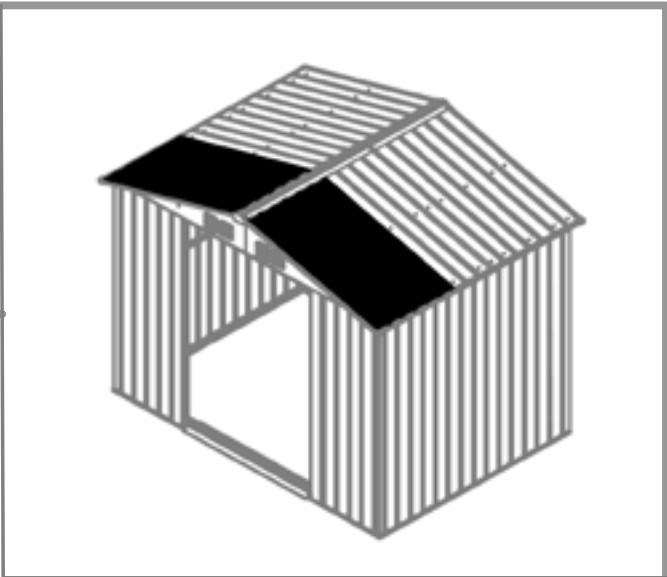

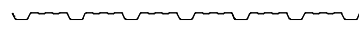

P8 (×2)

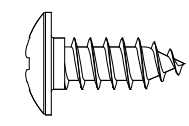

F1 (×24)



S3 (×24)

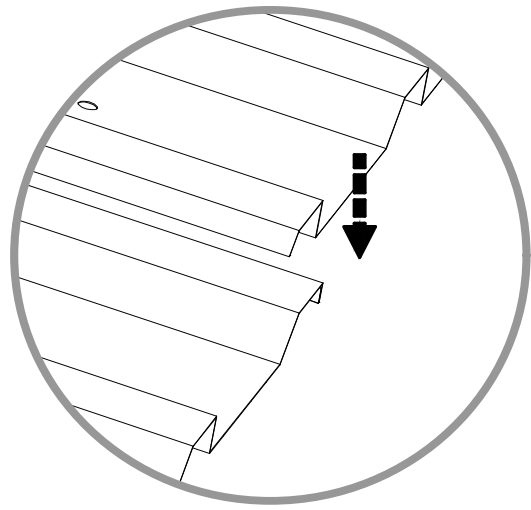
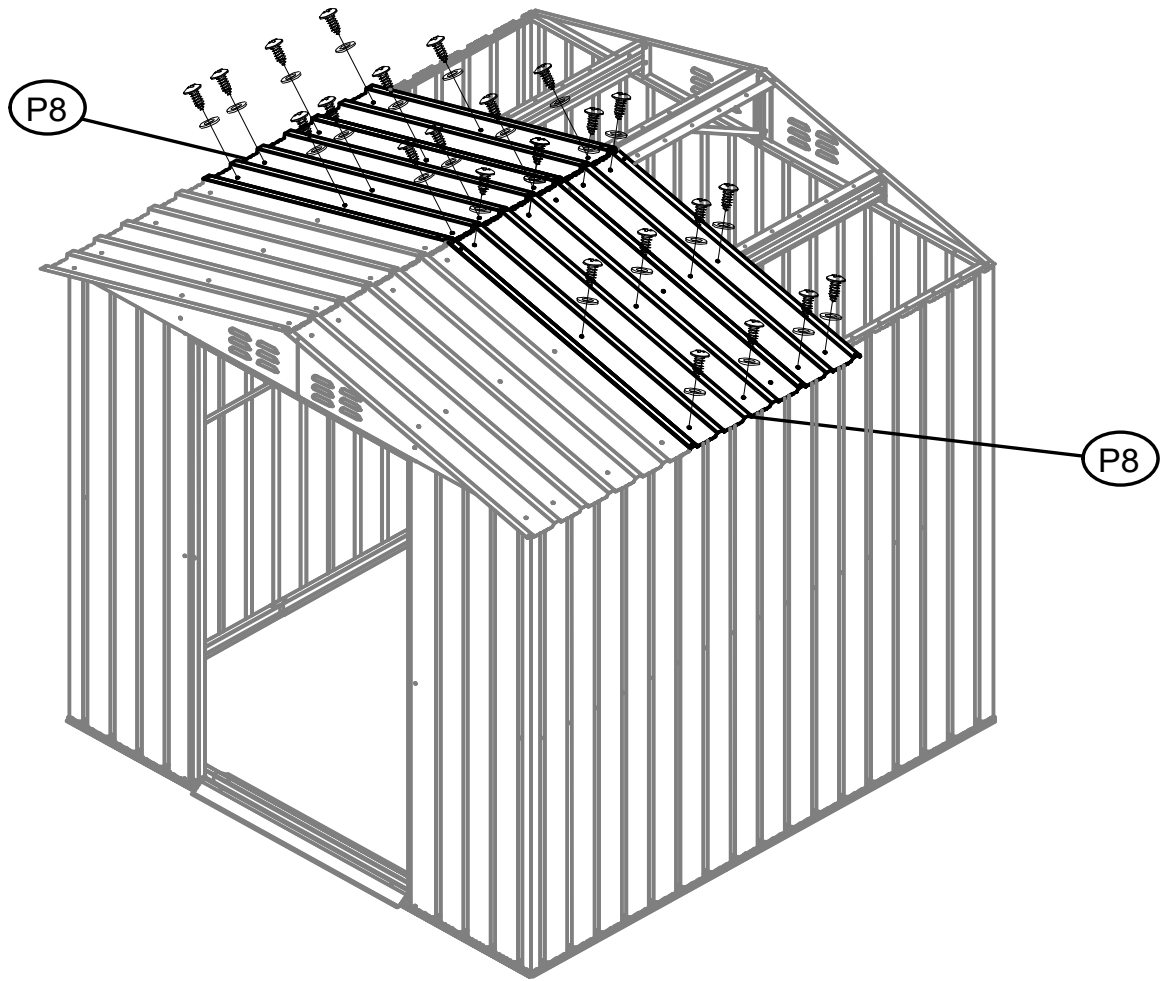
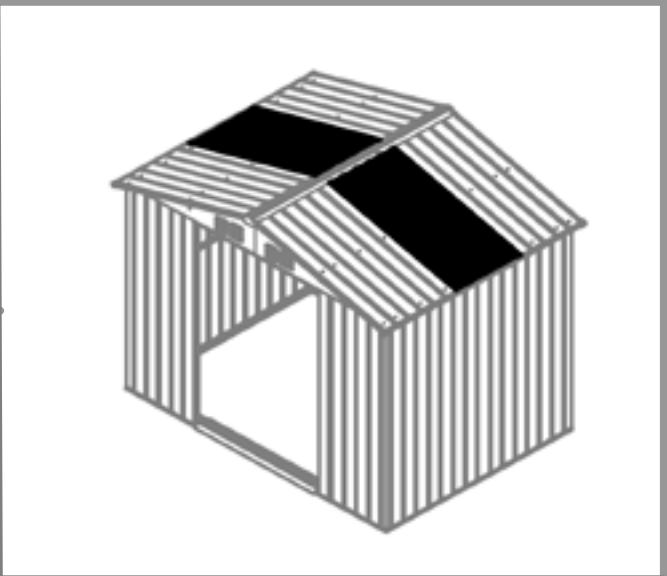

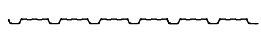

P5 (×1)

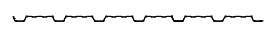

P6 (×1)

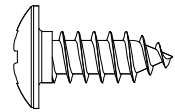

F1 (×24)



S3 (×24)

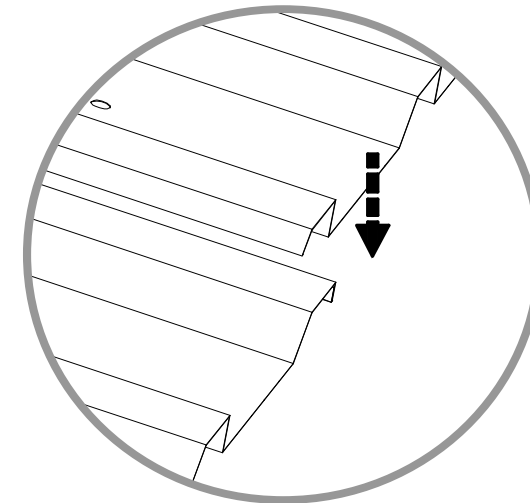
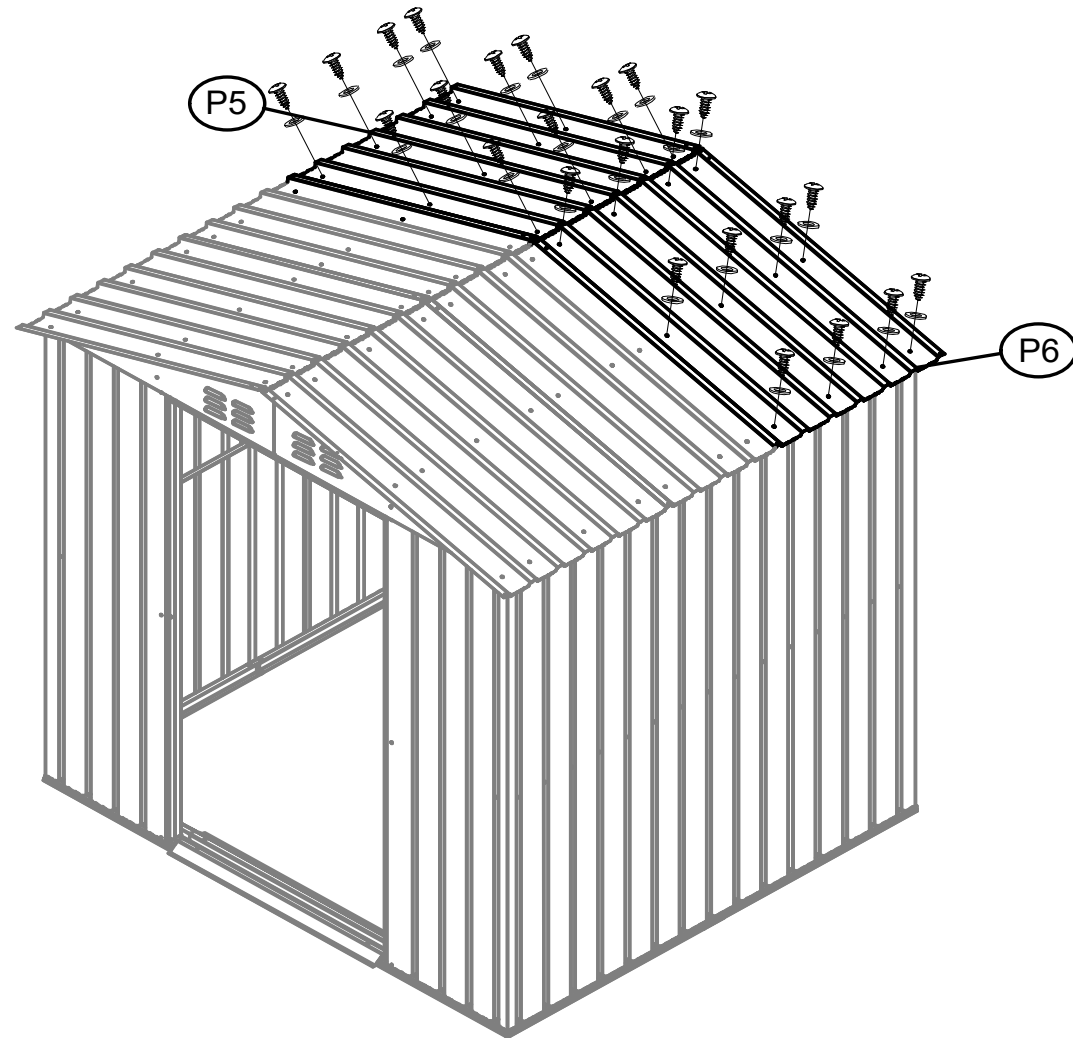

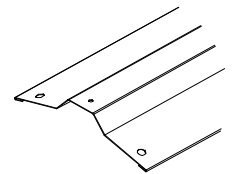
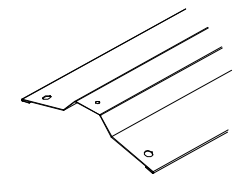
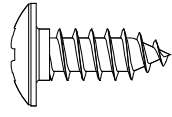
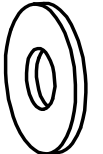
 19 (×1)	 20 (×1)	 F1 (×5)	 S3 (×5)
--	---	--	--

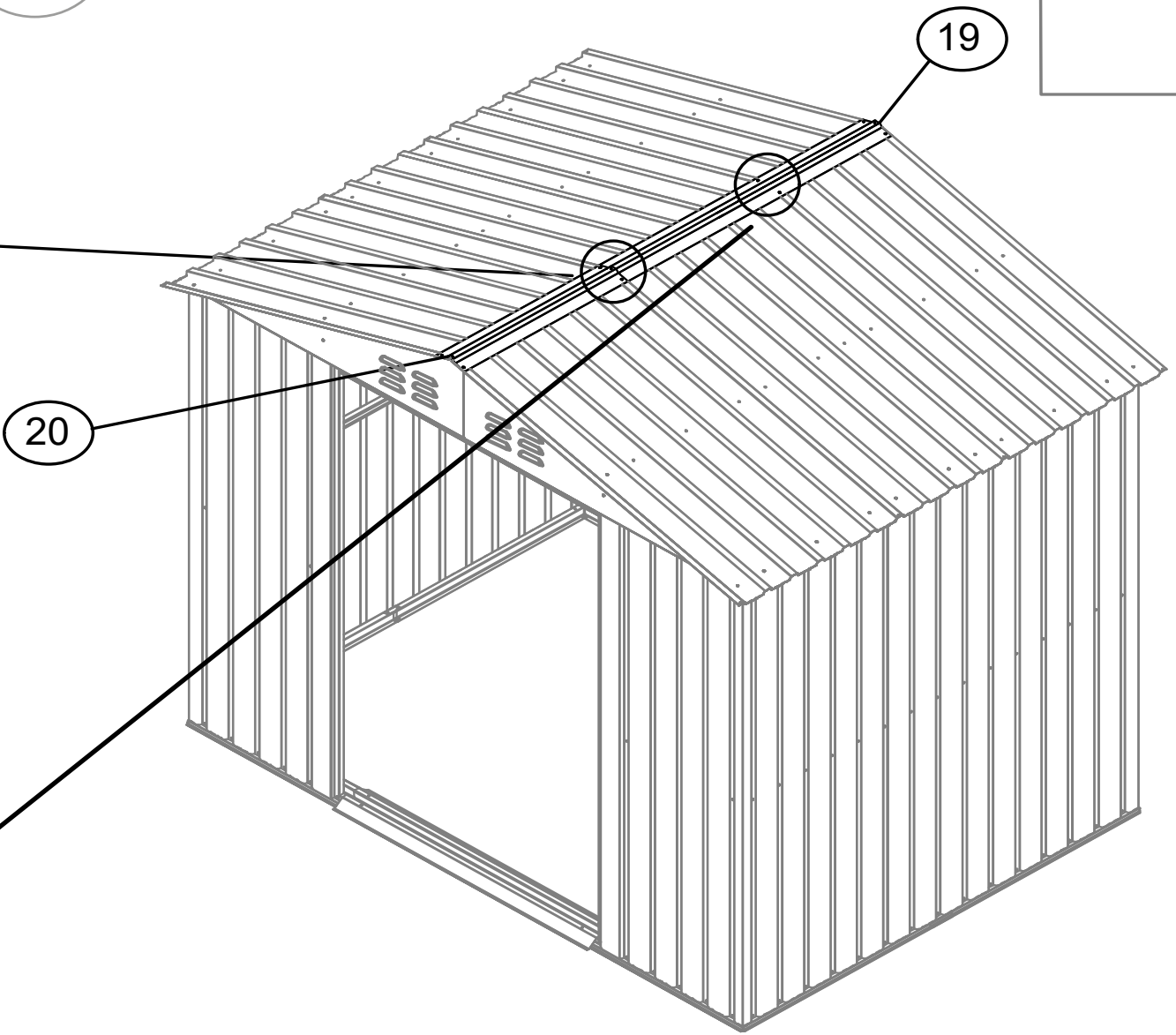
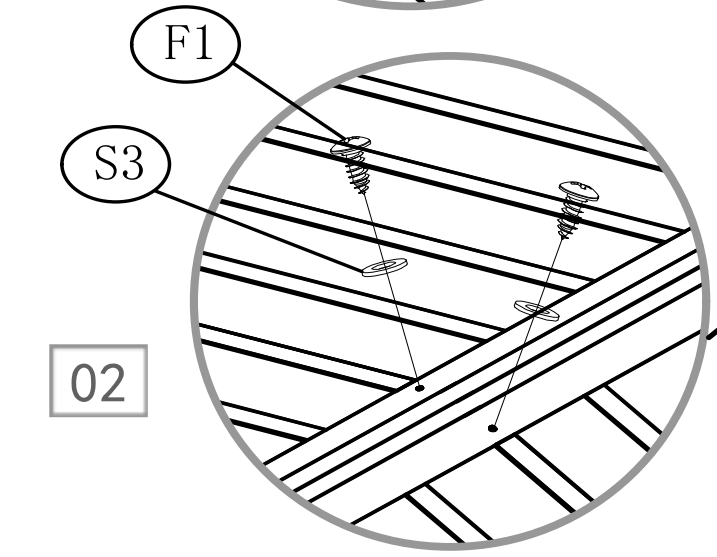
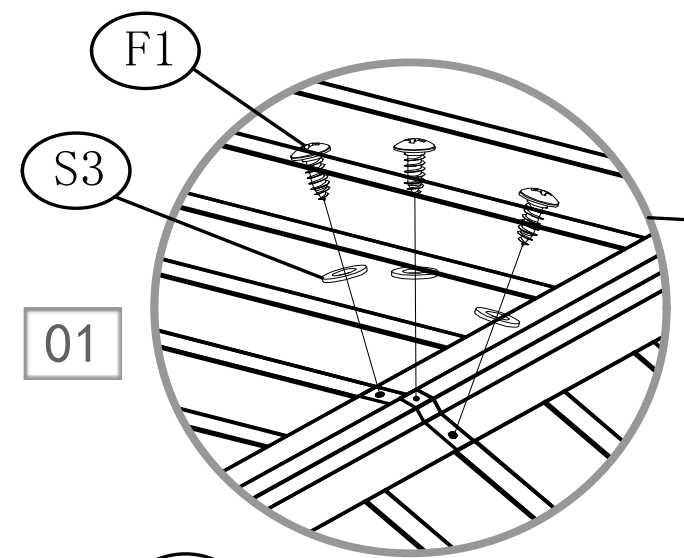
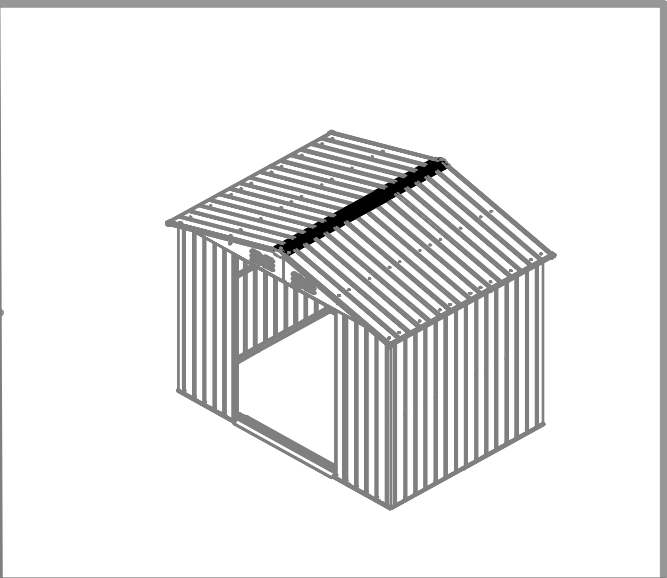

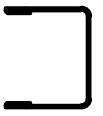

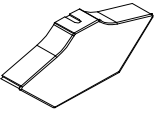
17 (×4)

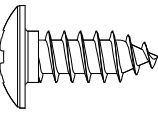
GE (×2)

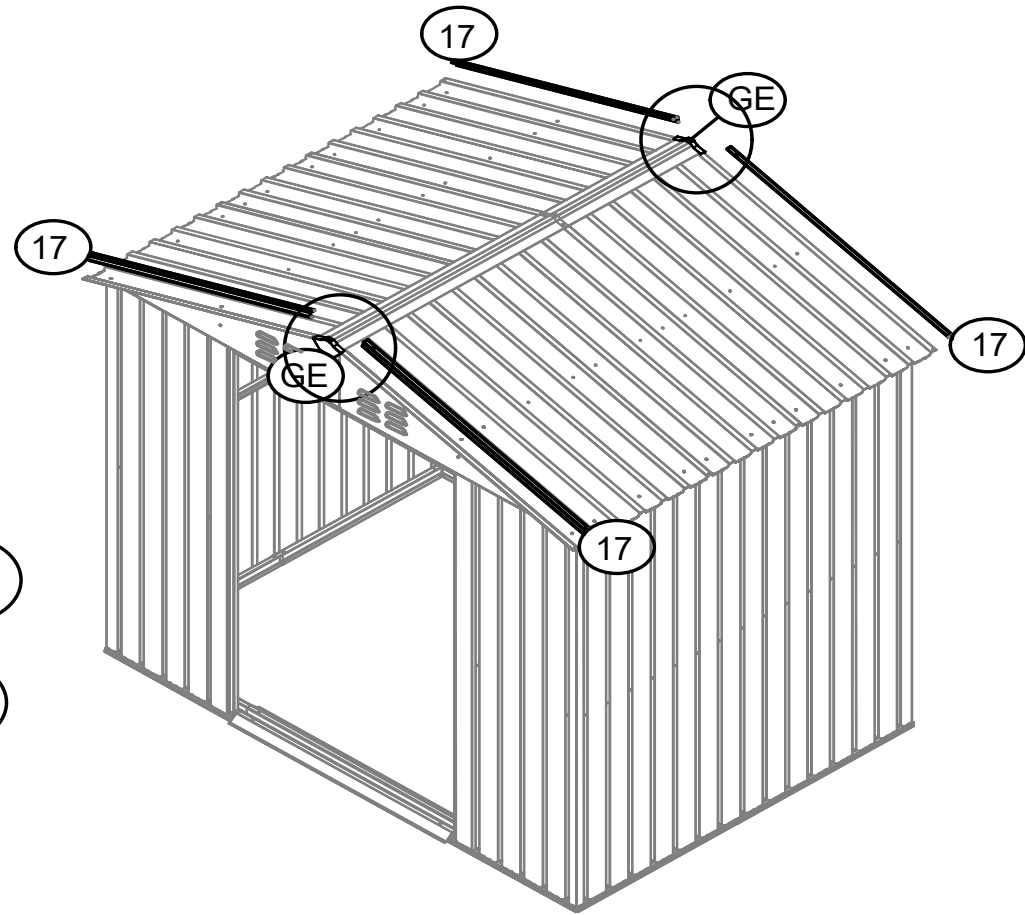
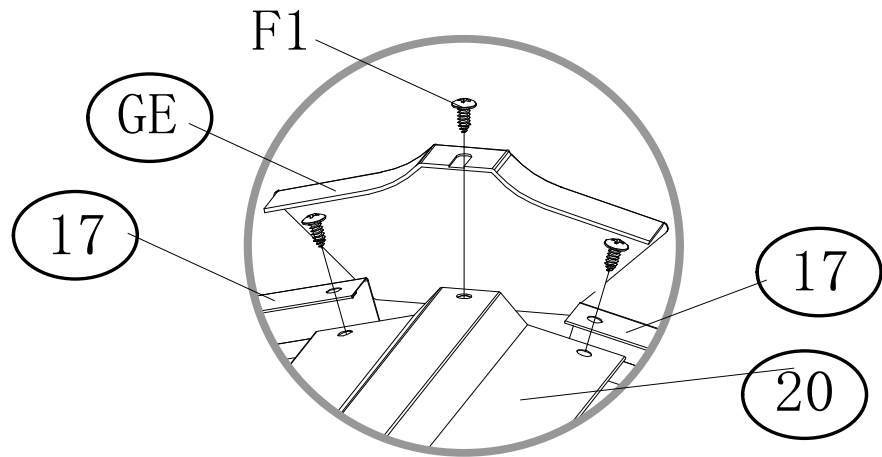
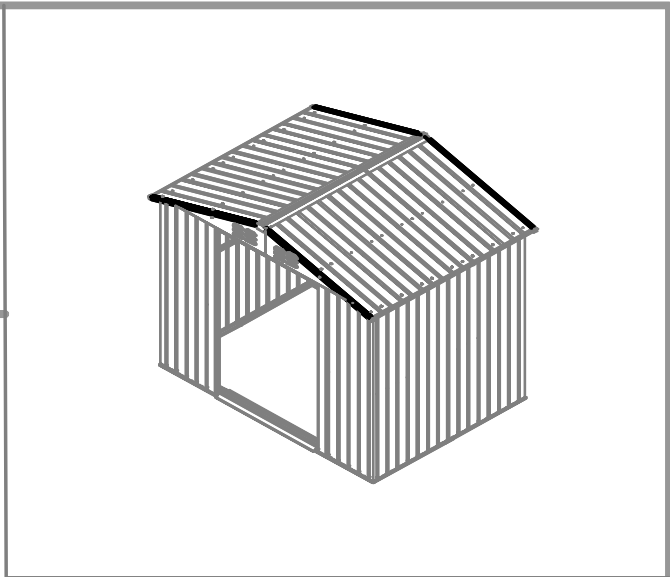

F1 (×6)

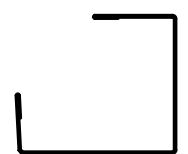

31

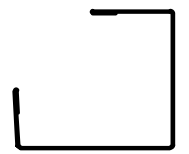

15-2 (×1)



24-1 (×1)



GS (×2)

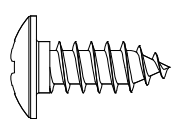

F1 (×4)

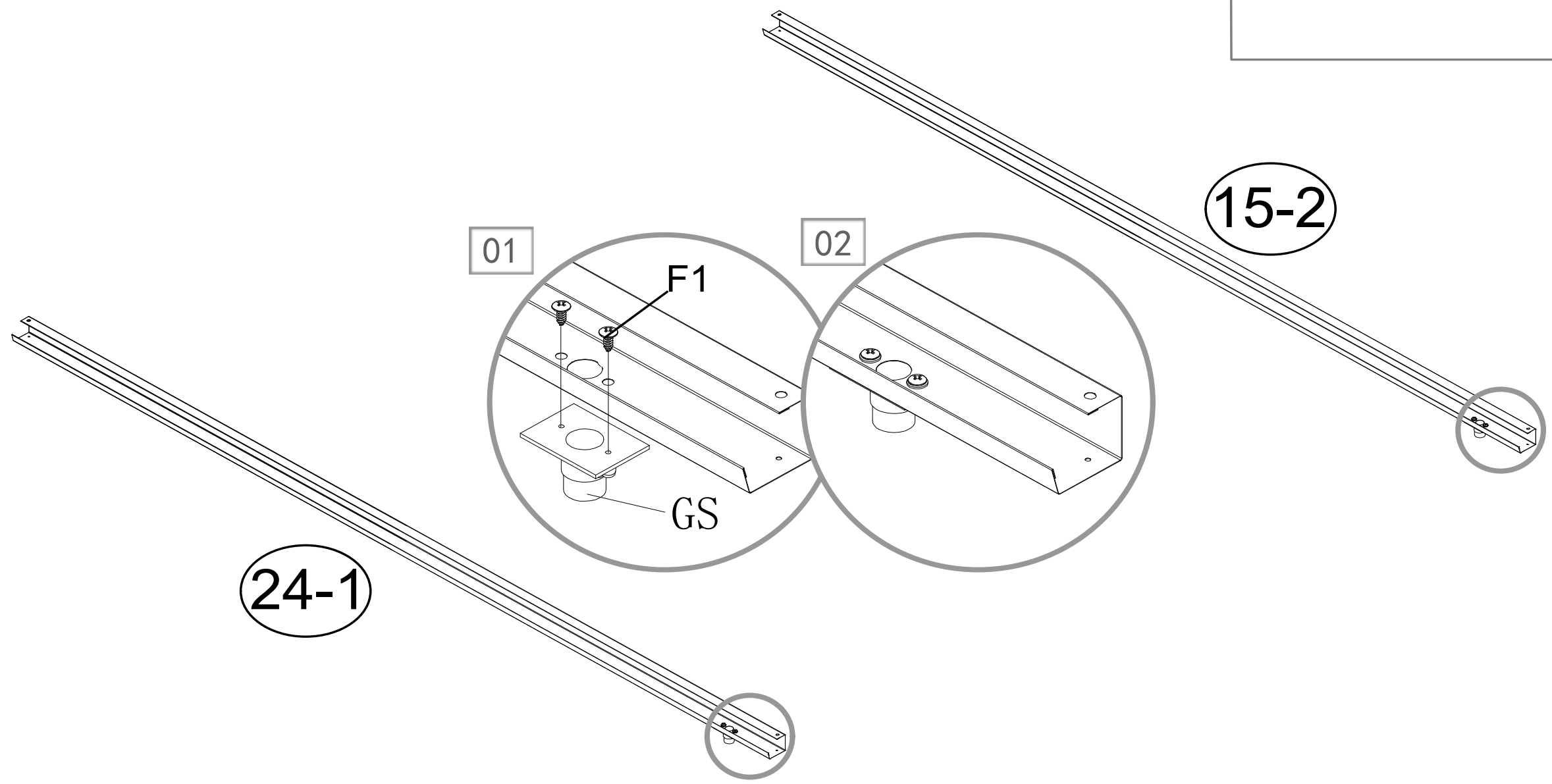
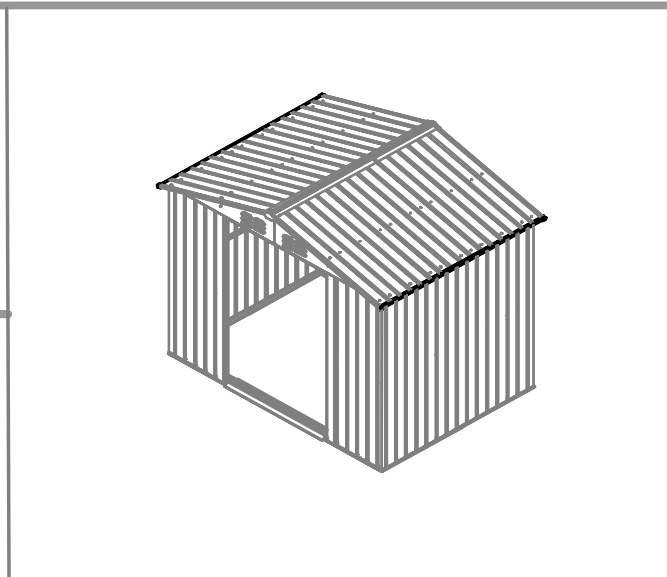

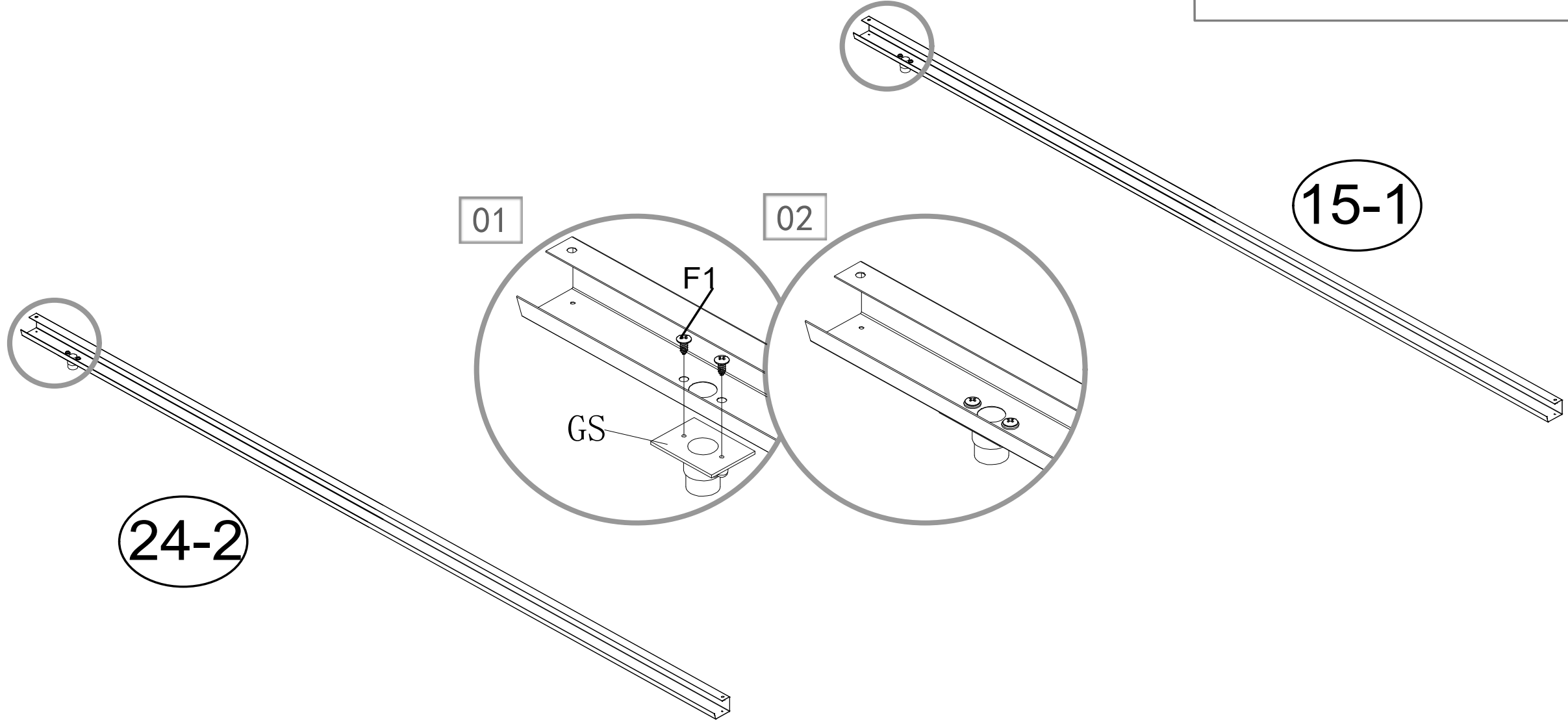
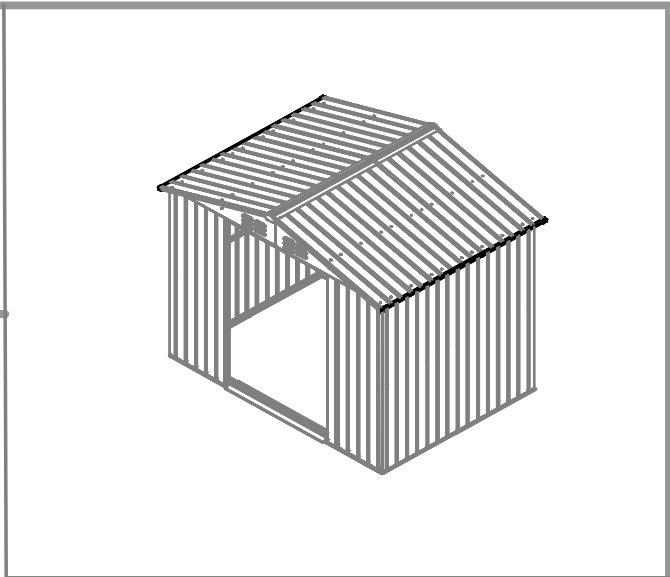
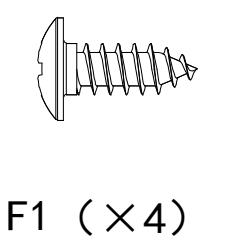
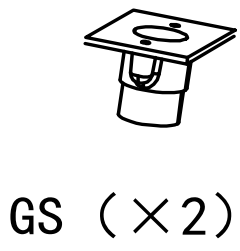
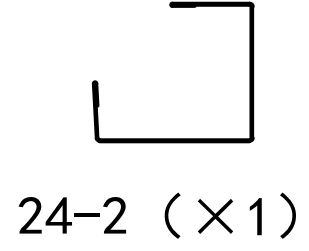
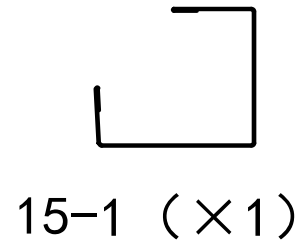

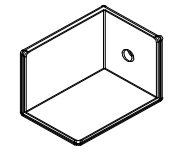

GC (×4)

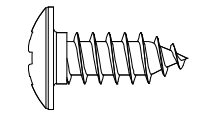

F1 (×8)

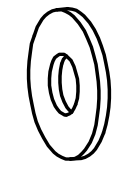

S3 (×8)

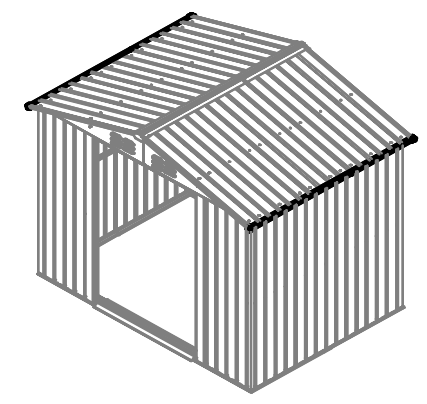

01

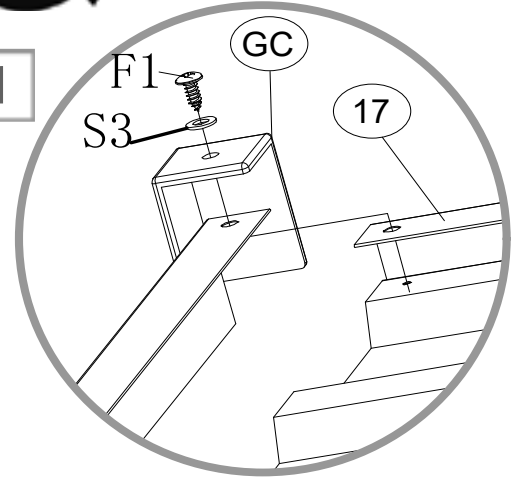

I

02

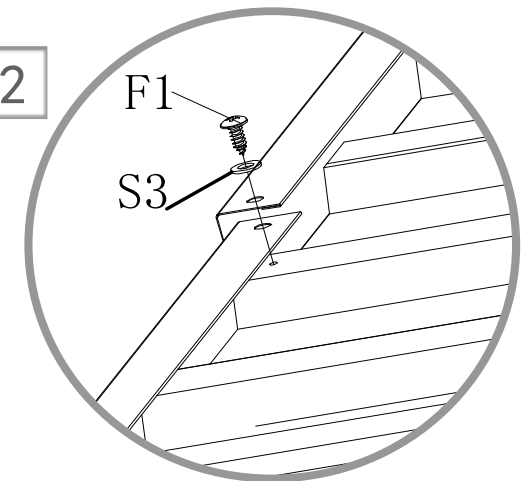

II

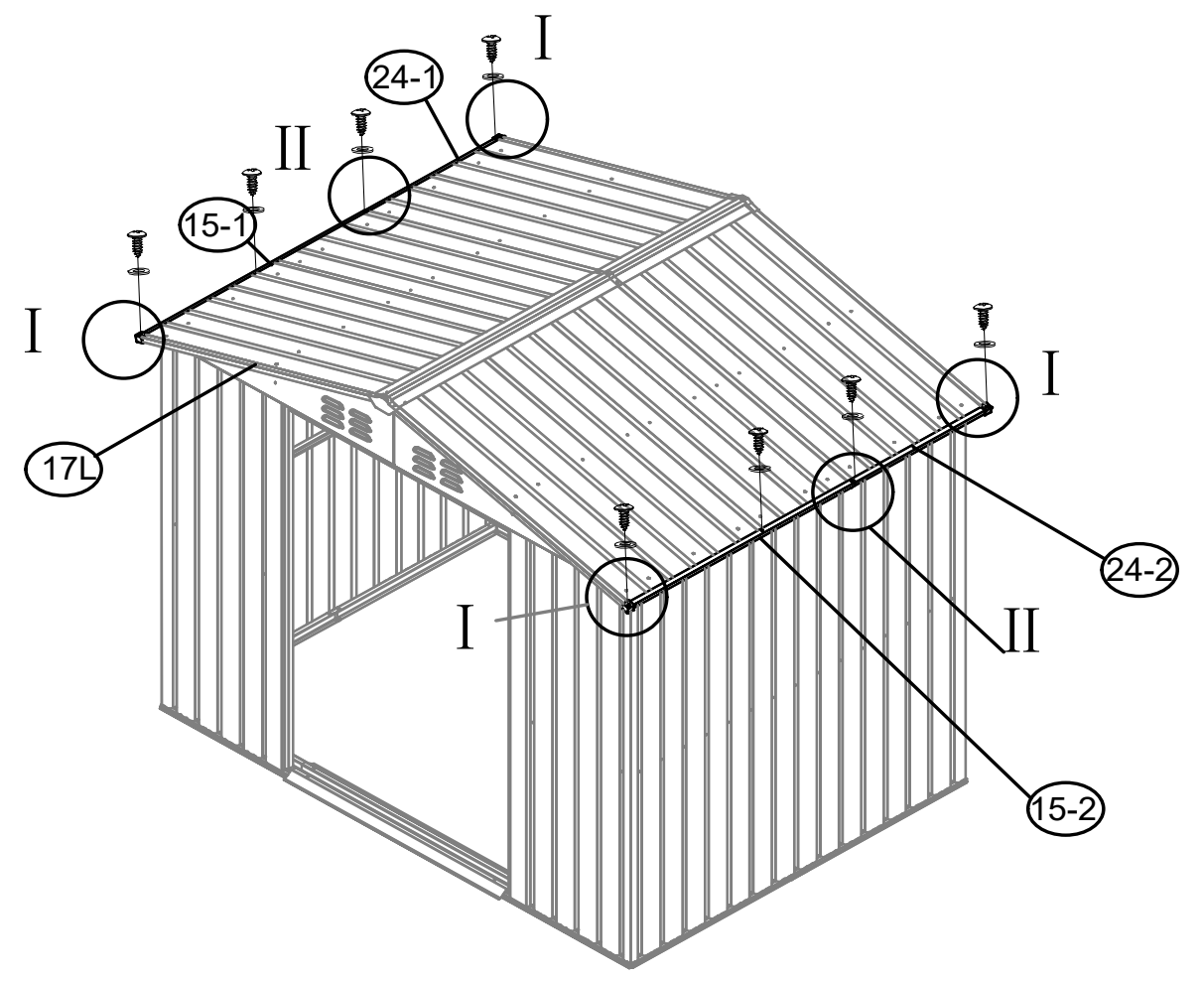



D1 (×1)

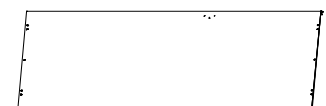

D2 (×1)

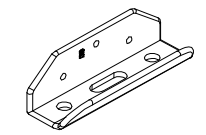

GB (×1)

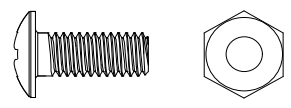

F2 (×2)

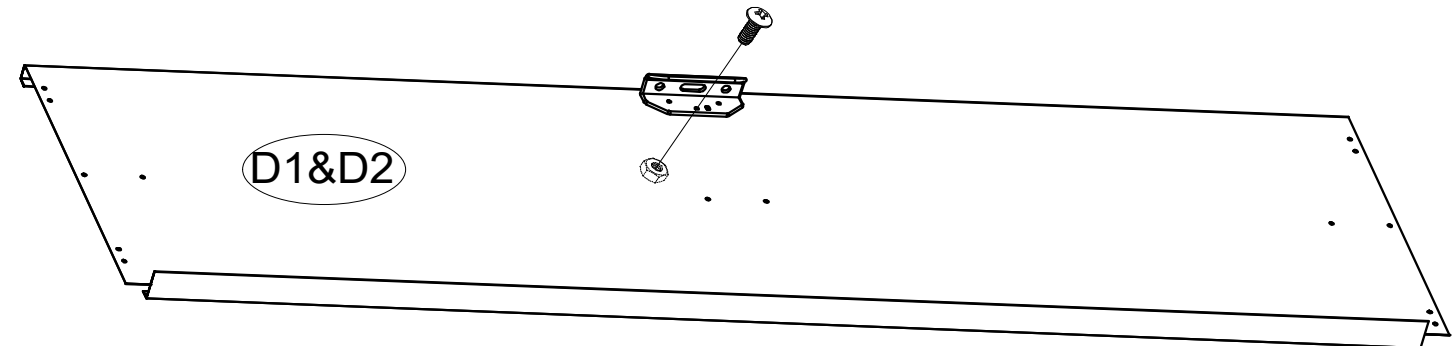
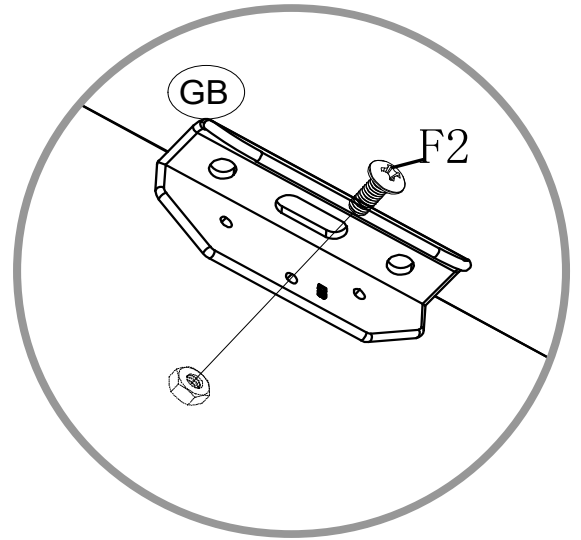
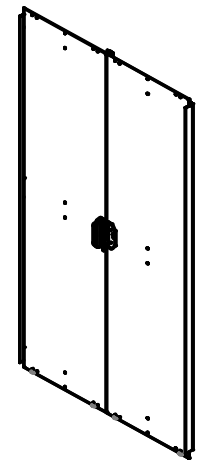

x2

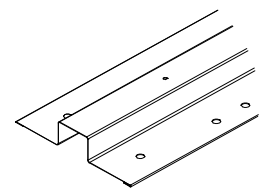

18 (×3)

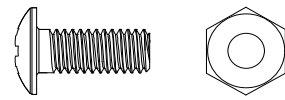

F2 (×6)

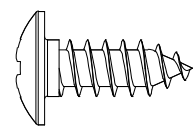

F1 (×8)



S3 (×14)

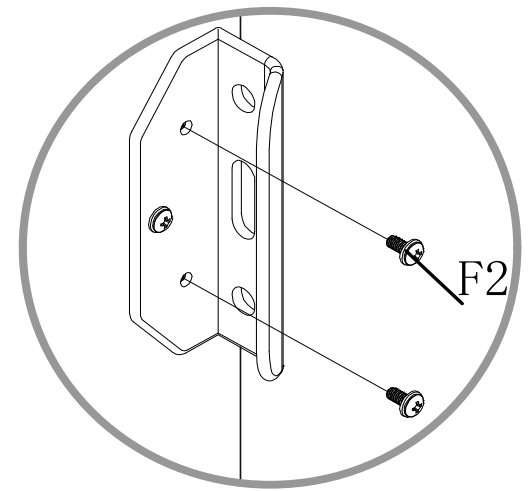
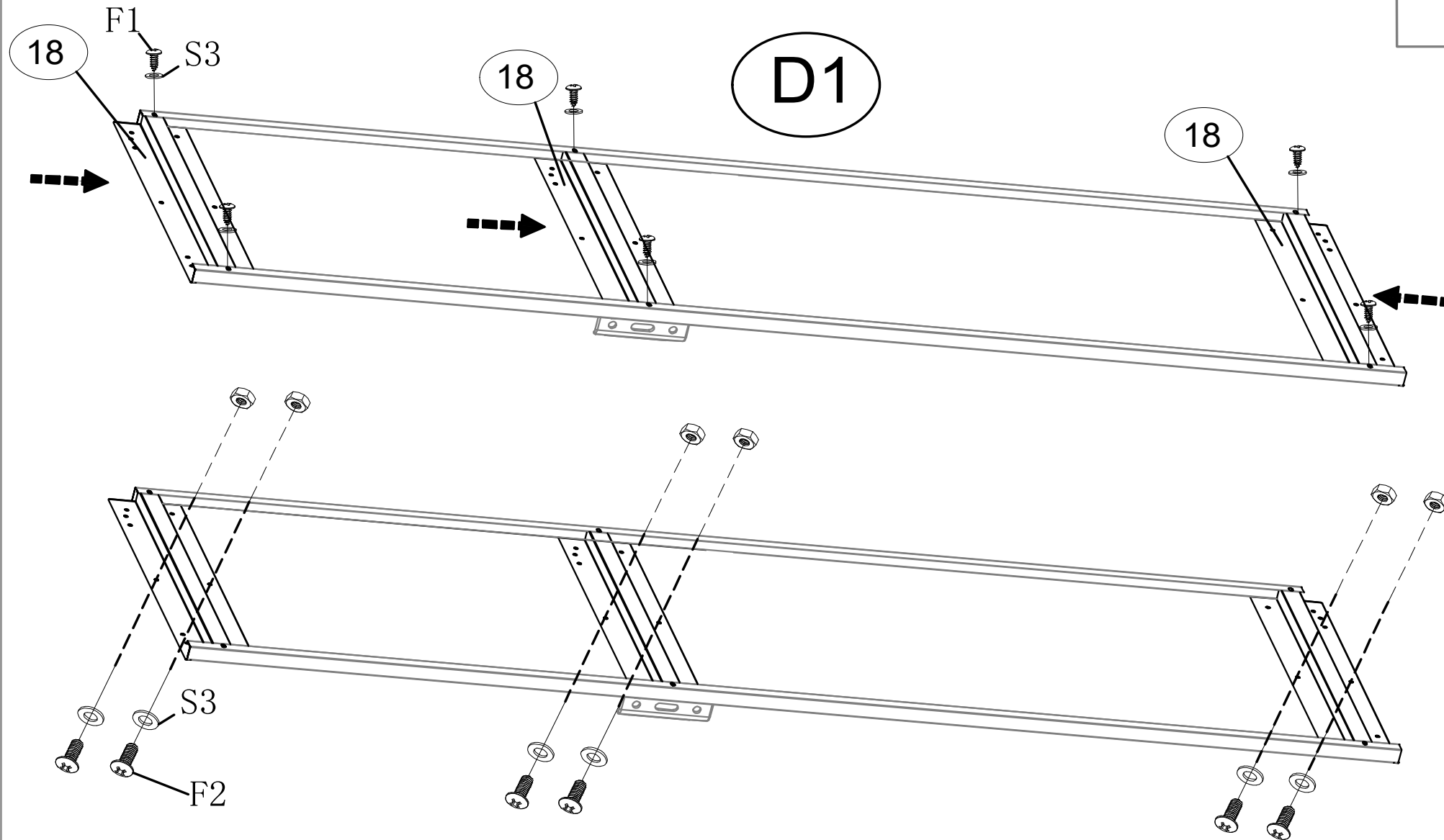
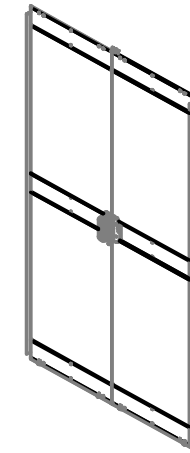

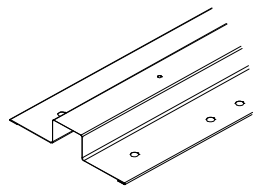

18 (×3)

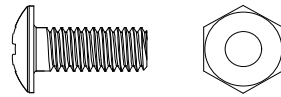

F2 (×6)

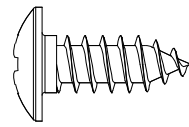

F1 (×8)



S3 (×14)

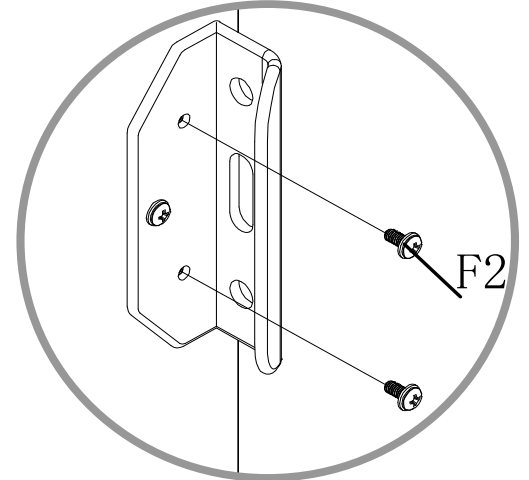
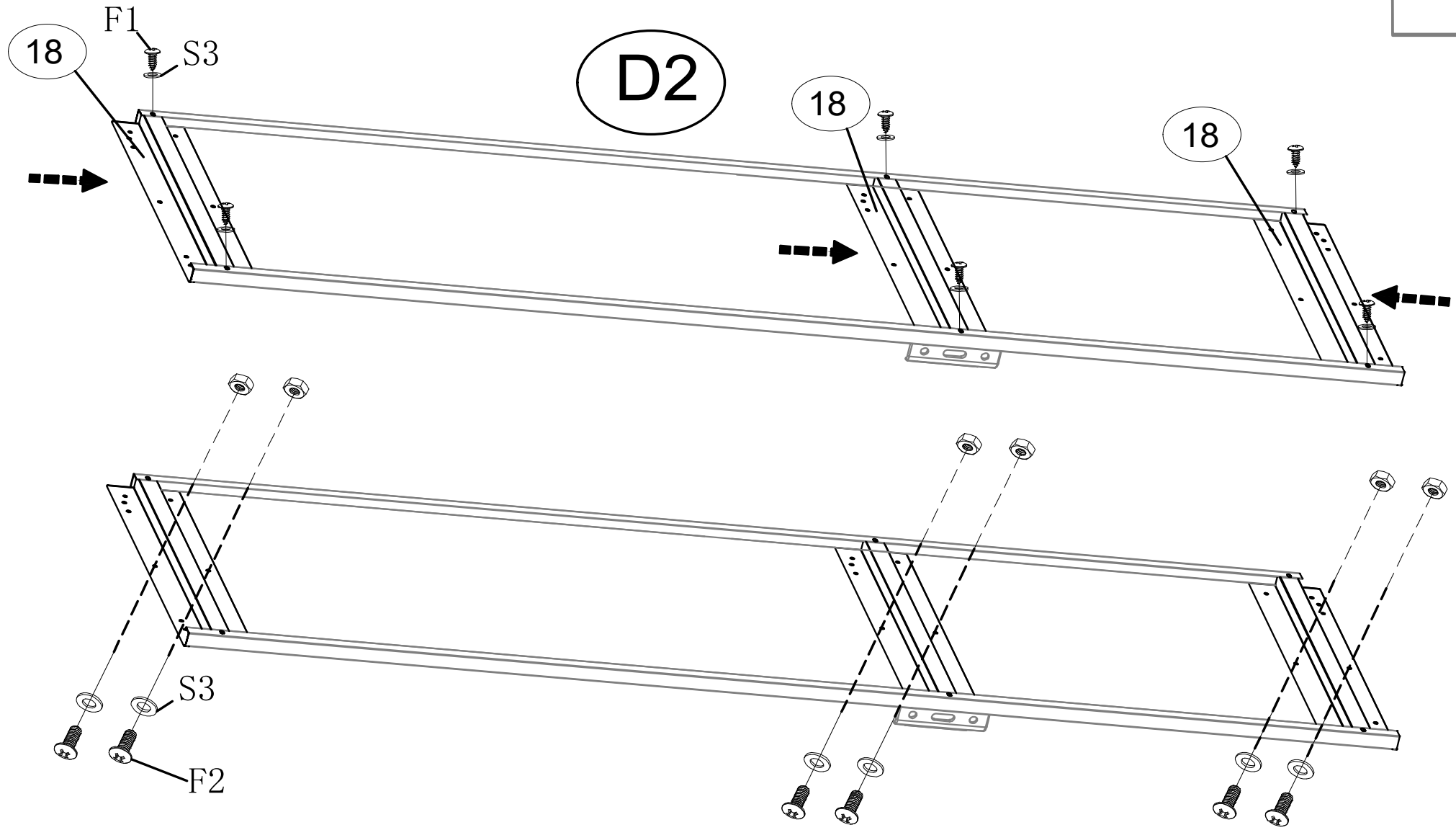
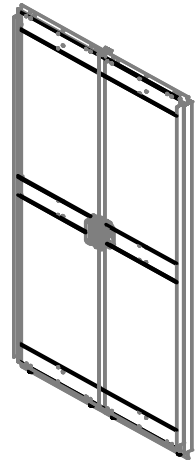

37

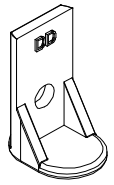

GD (×4)

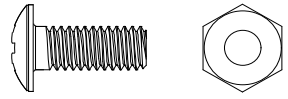

F2 (×4)

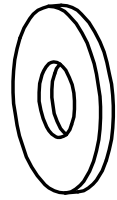

S3 (×4)

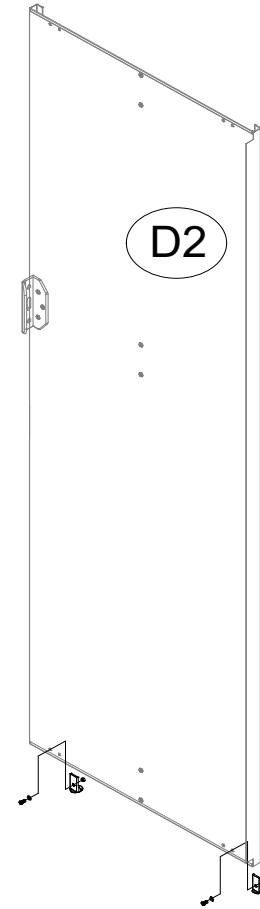
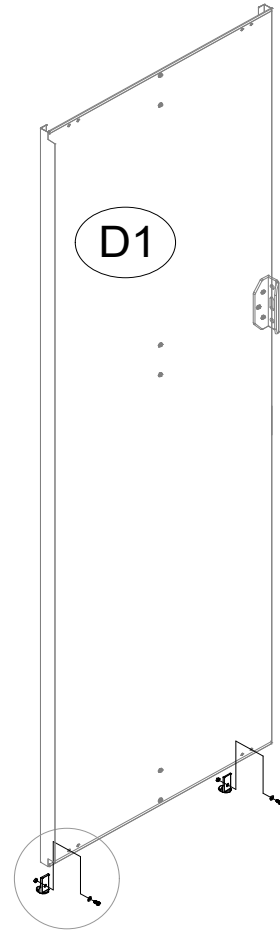
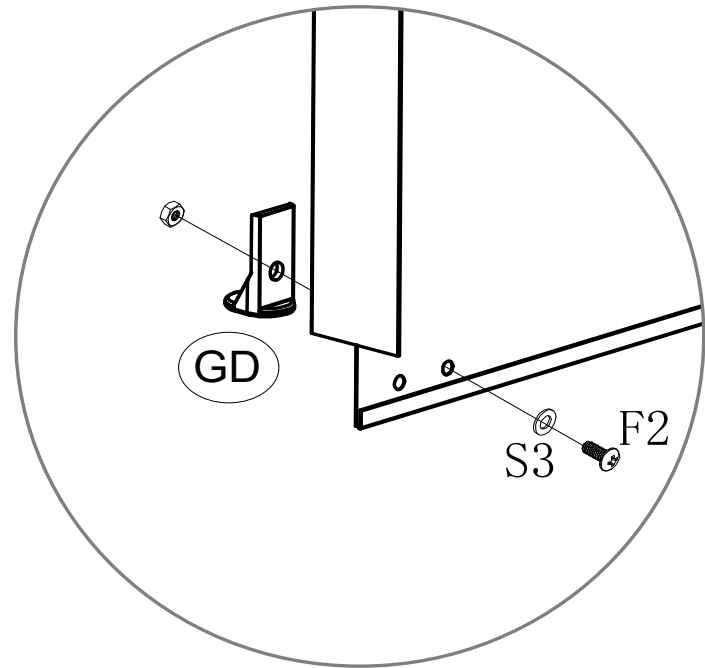
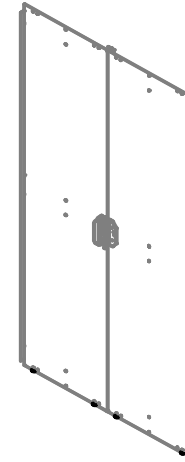

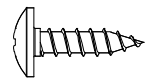

F3 (×8)

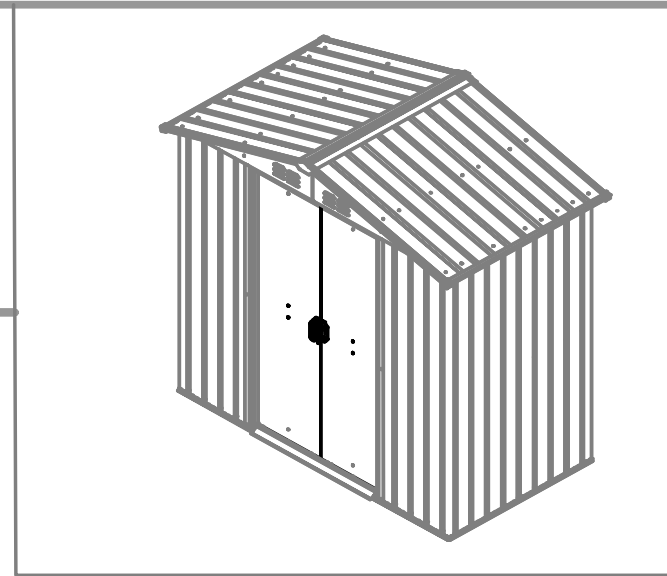
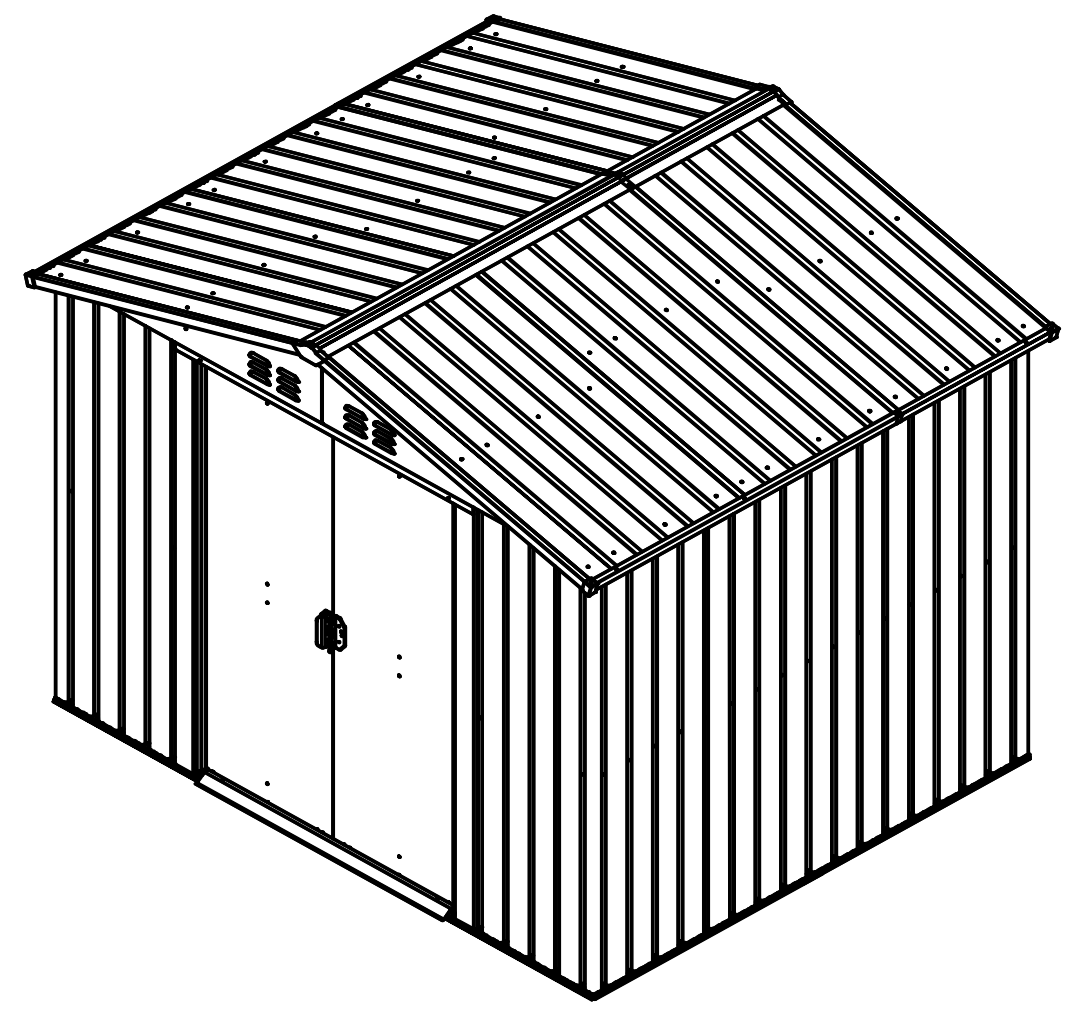
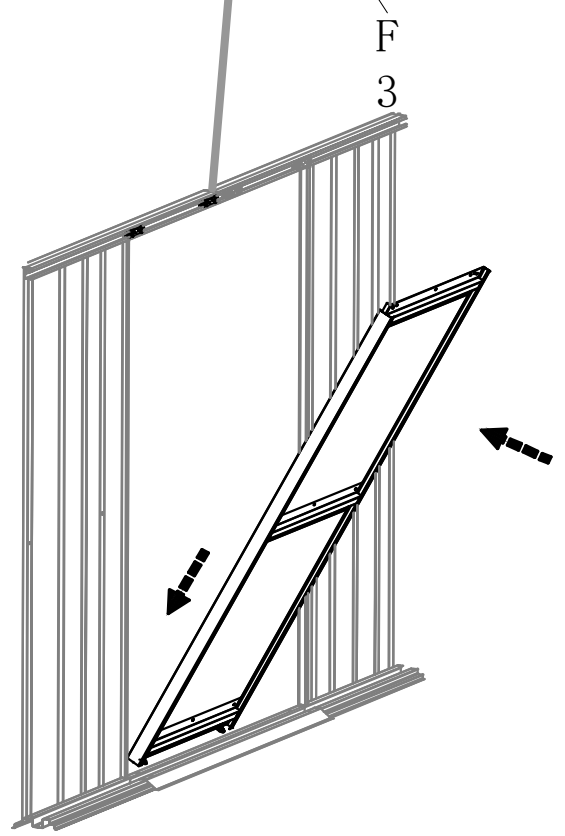
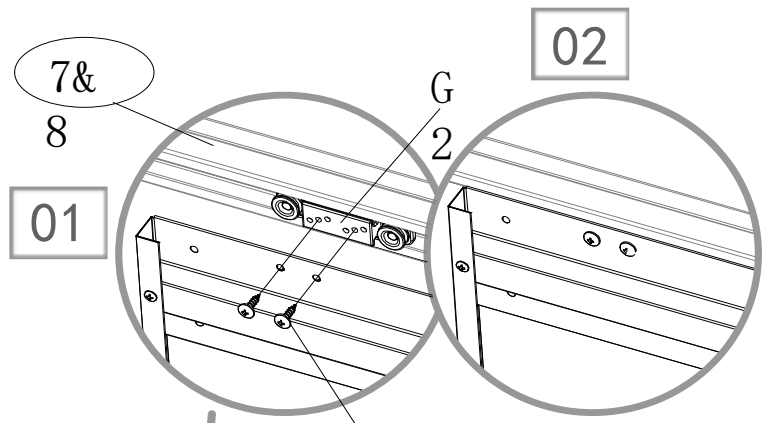

39



J1 (×4)

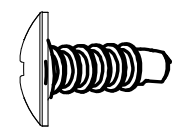

F7 (×16)

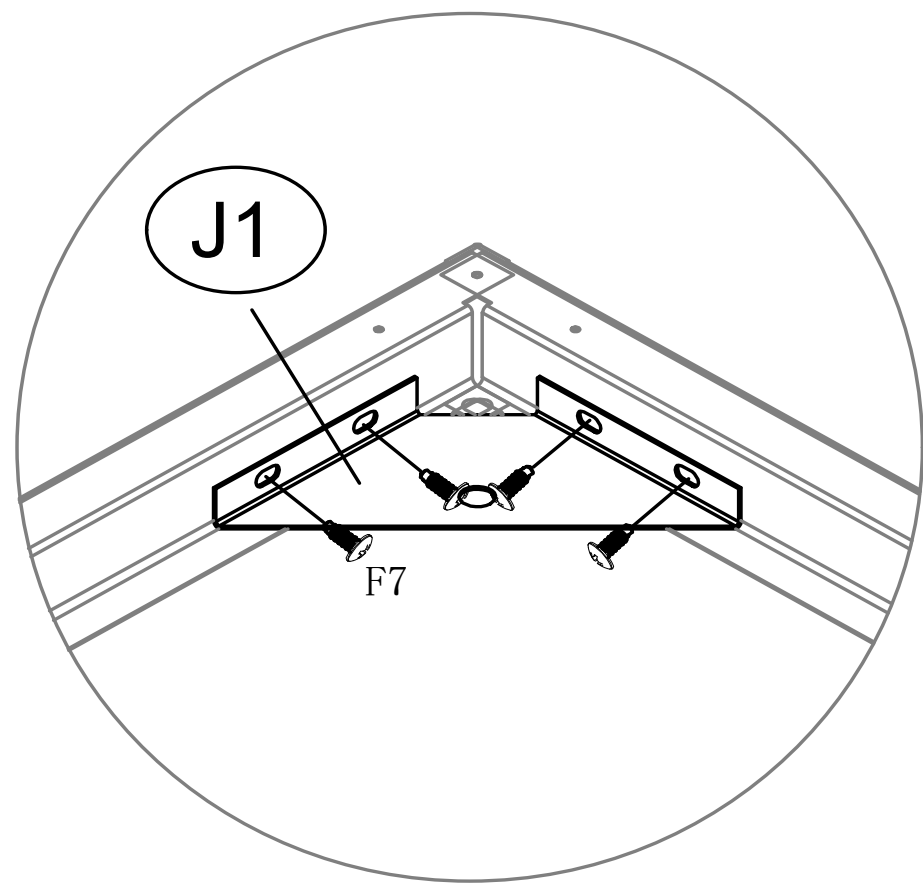
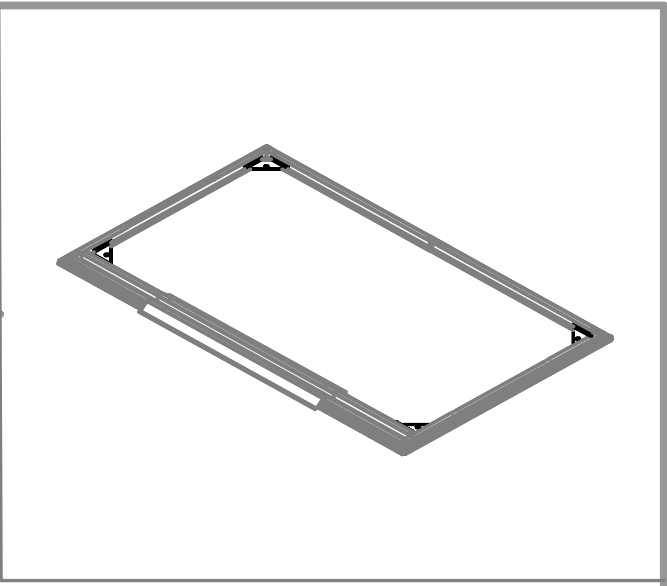

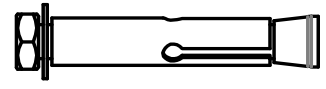

F10 (×4)

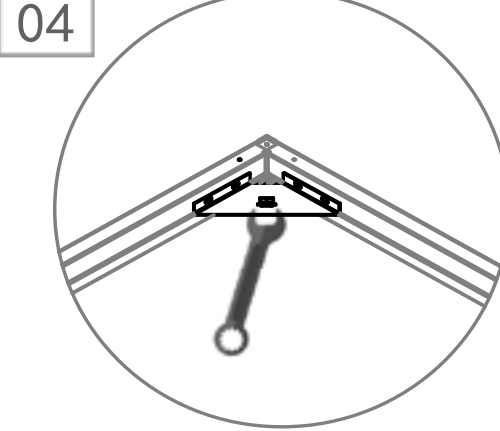
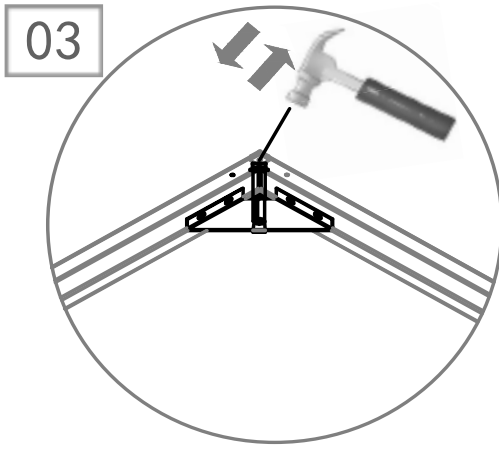
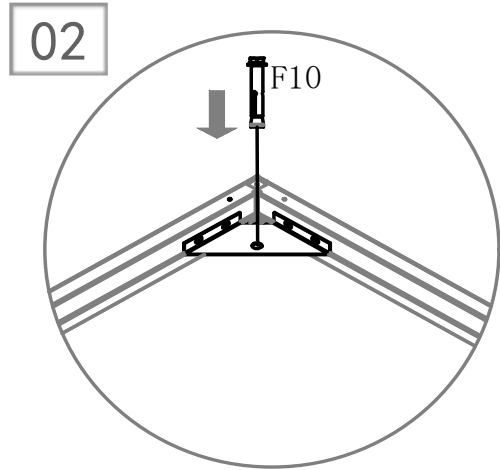
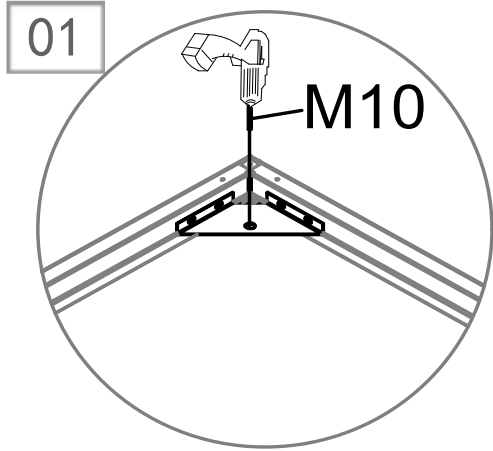
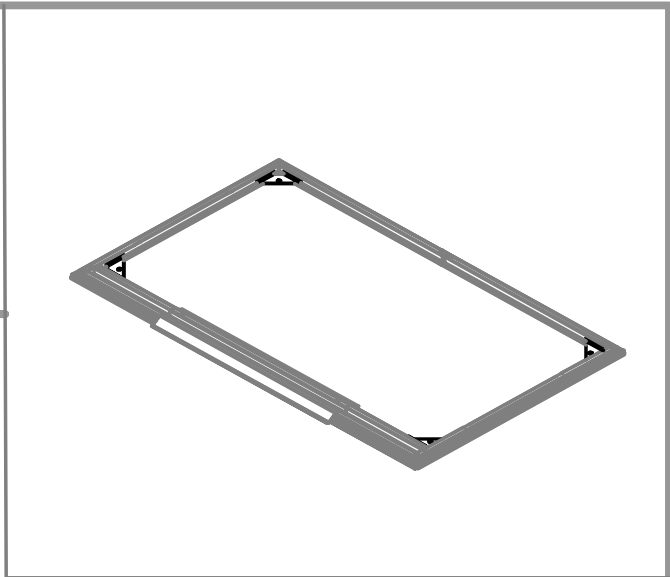

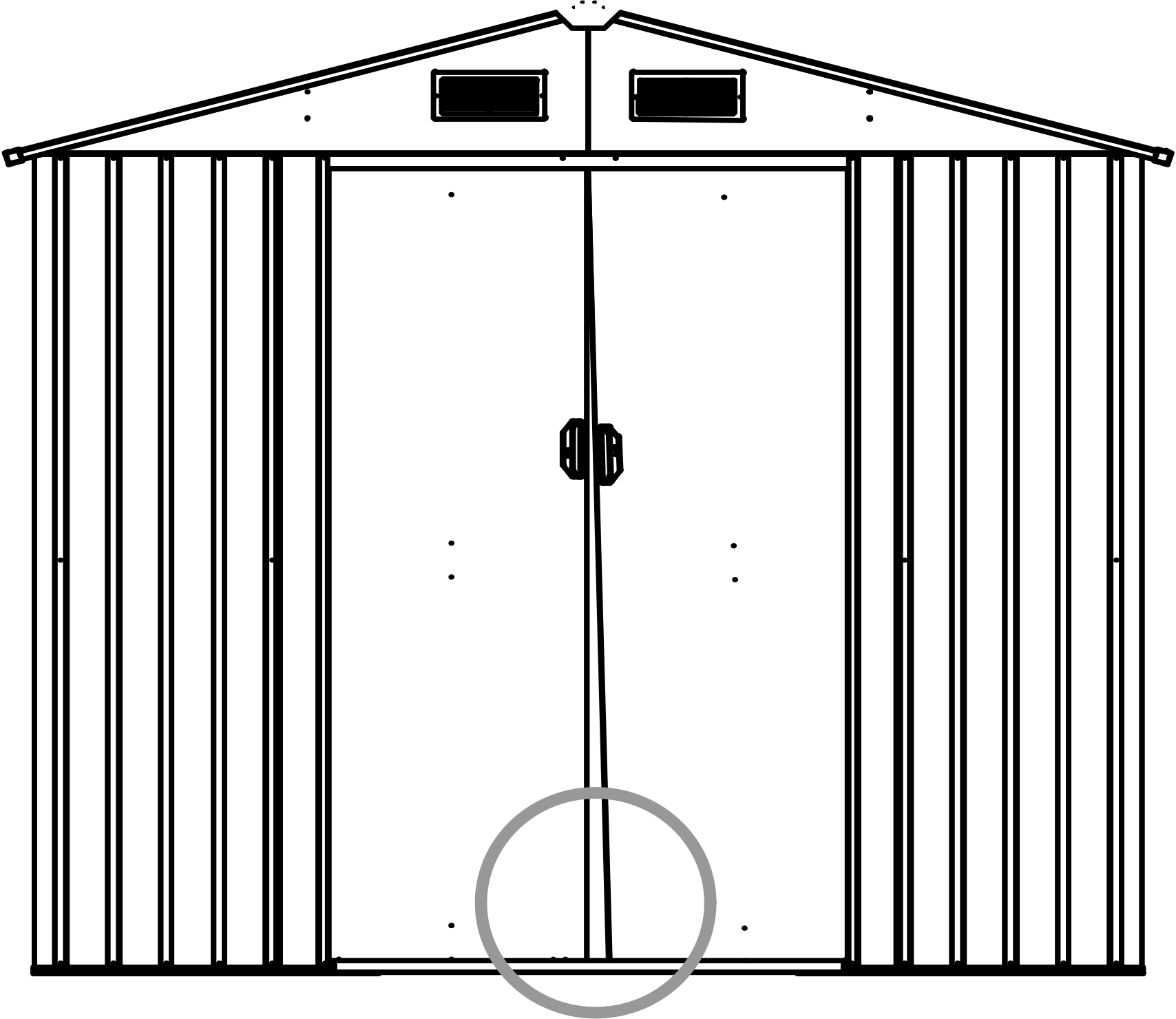

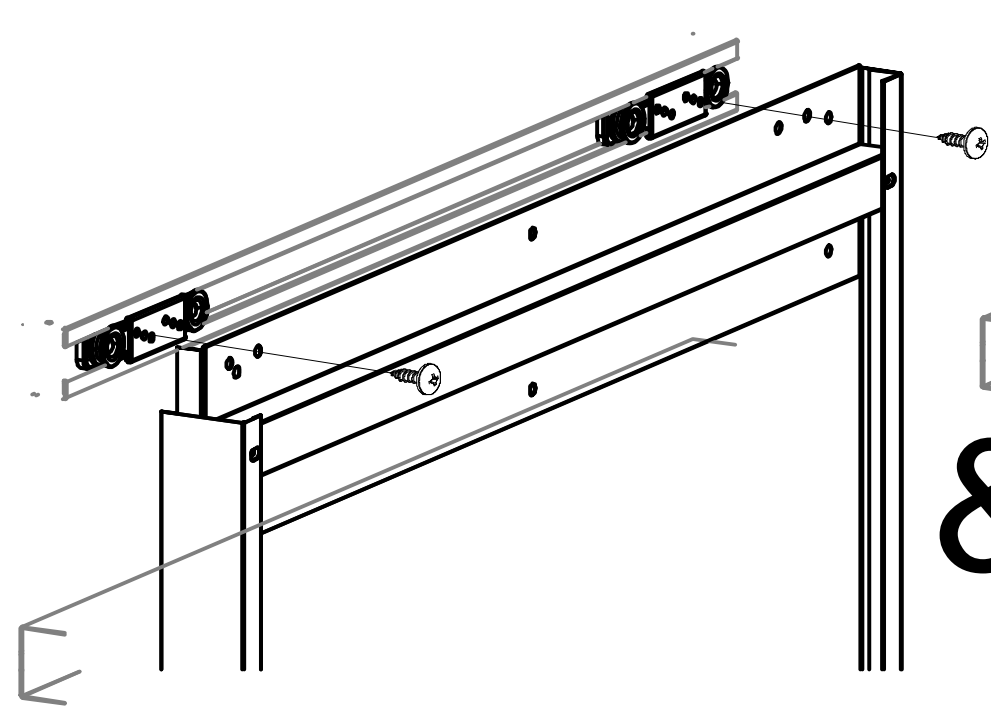
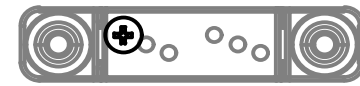
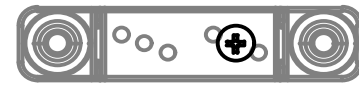
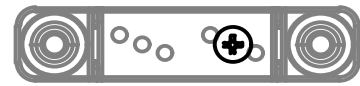
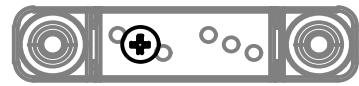

&

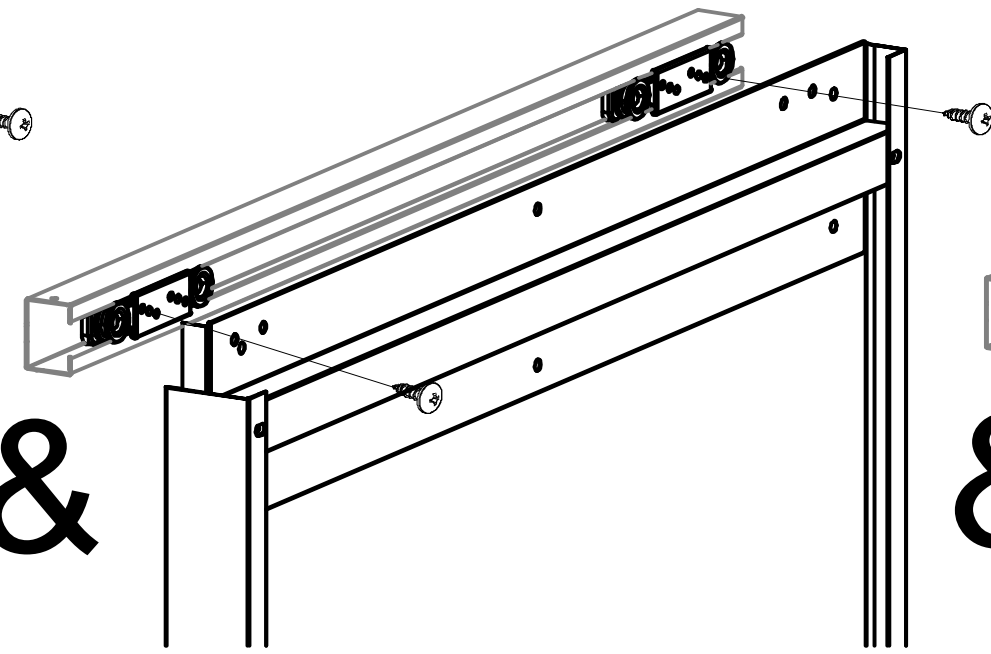

&

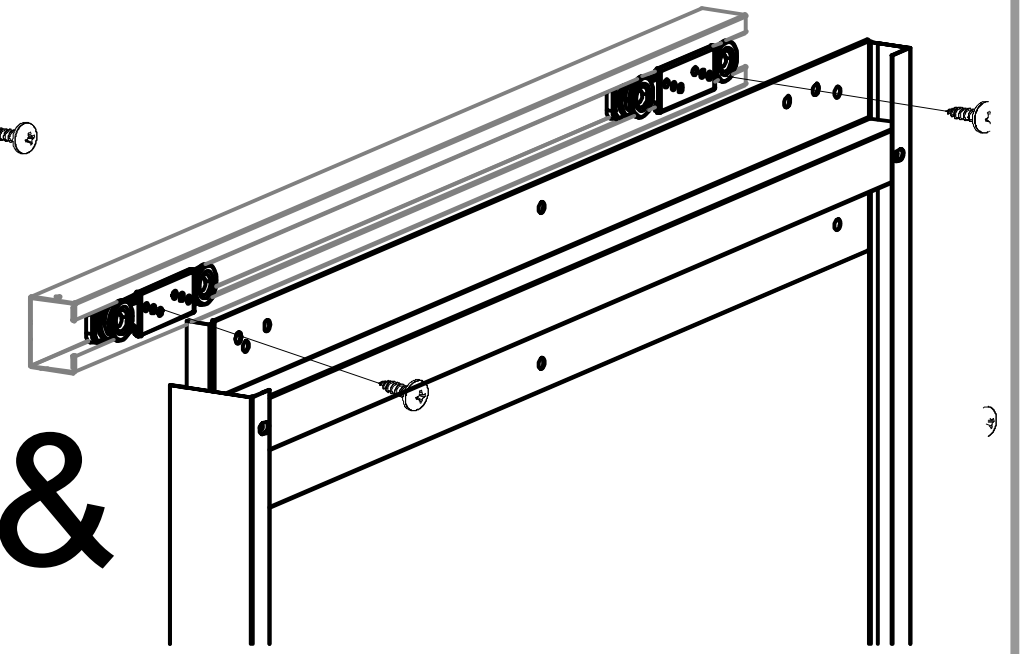

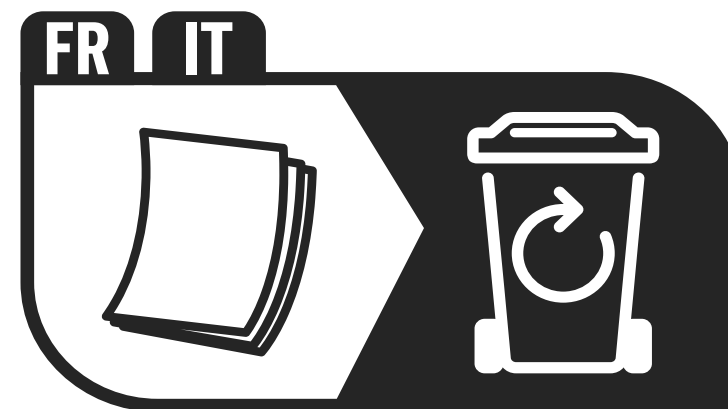

DESCARTE SELETIVO