

# Naterial

**Denali**  
2,40×1,80m / 12mm

**3**  
YEAR  
Warranty\*

**1**  
YEAR  
Warranty\*\*

2/2

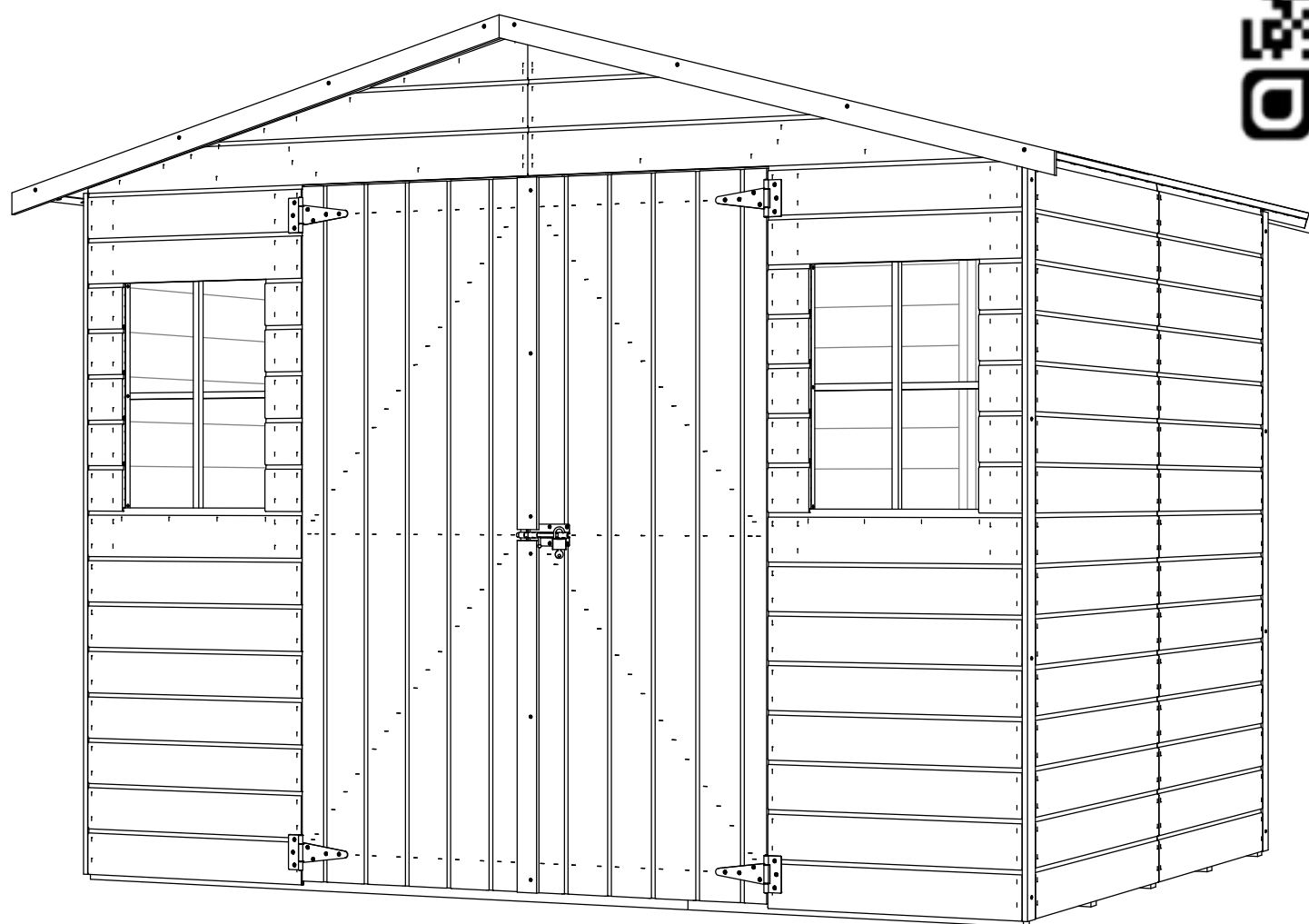
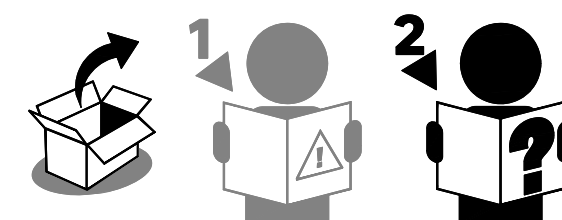

EAN : 3276007889758

MATRIX ID : 2025R09P11-0003

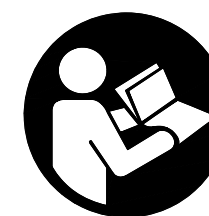
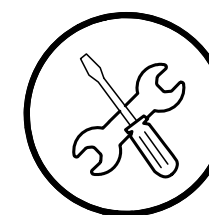

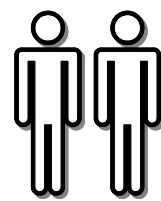
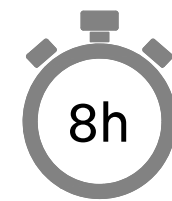
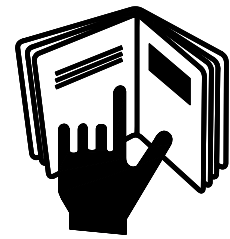

max. 50kg/m<sup>2</sup>

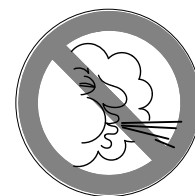

max. 50km/h

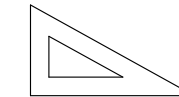
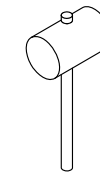
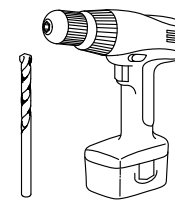
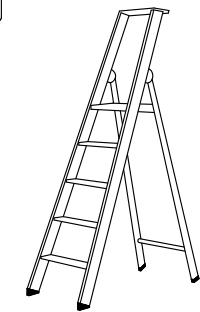
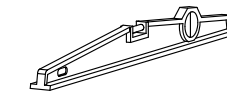
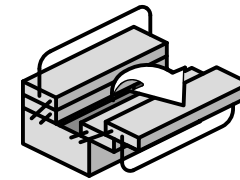
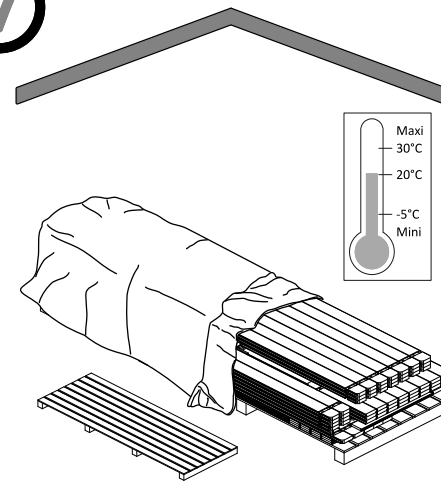
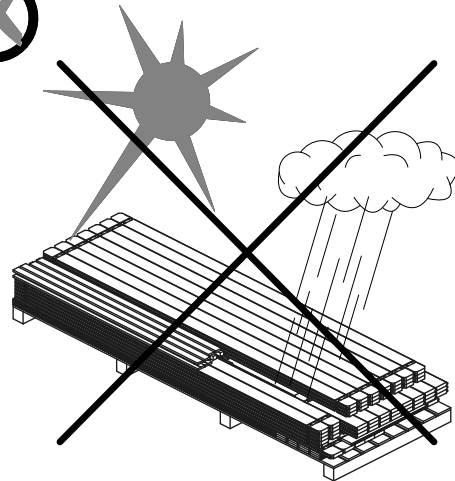
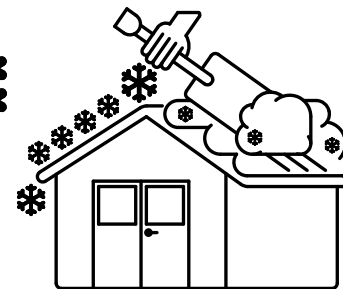

1

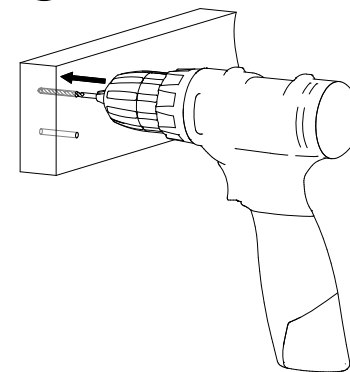

2

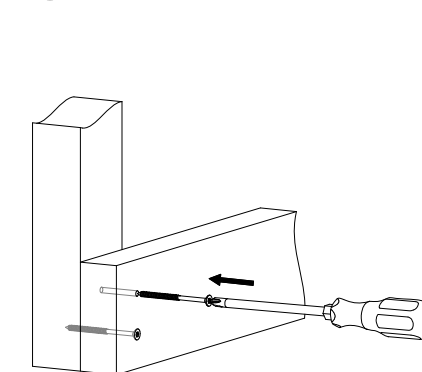

3

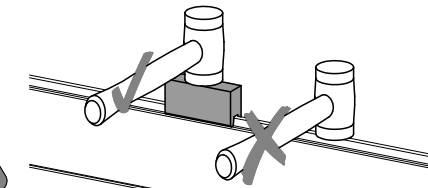
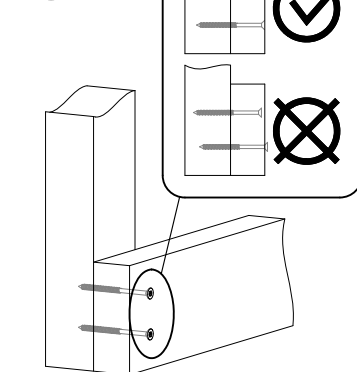

✓

✗

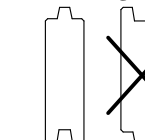

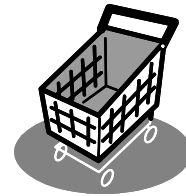

**FR** Colle pour le feutre bitumeux.  
**IT** Colla per tela buttumata.  
**UA** Адезив pentru membrană bituminoasă.

**ES** Pegamento para tela asfáltica.  
**EL** Κόλλα για ασφαλτόπανο.  
**RO** Клей для бітумінізованого войлоку.

**PT** Cola para tecido asfáltico.  
**PL** Klej do papy bitumicznej.  
**EN** Glue for the roof.

**Silicone Mastic**

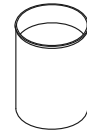
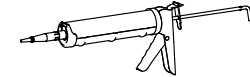

**FR** Protection pour le bois en extérieur : 2 couches avant montage.

**IT** Protezione per il legno in esterno : due mani prima del montaggio.

**UA** Προστασία για ξύλινες επιφάνειες εξωτερικού χώρου: 2 στρώσεις πριν από τη συναρμολόγηση.

**ES** Protección para la madera de exteriores: 2 manos antes del montaje.

**EL** Προστασία για ξύλινες επιφάνειες εξωτερικού χώρου: 2 στρώσεις πριν από τη συναρμολόγηση.

**RO** Protecție pentru lemn la exterior: 2 straturi înainte de montaj.

**PT** Proteção para madeira exterior: 2 demãos antes da montagem.

**PL** Ochrona drewna na zewnątrz: 2 warstwy przed montażem.

**EN** Wood preserver for the outside: 2 layers before assembly.



## Denali

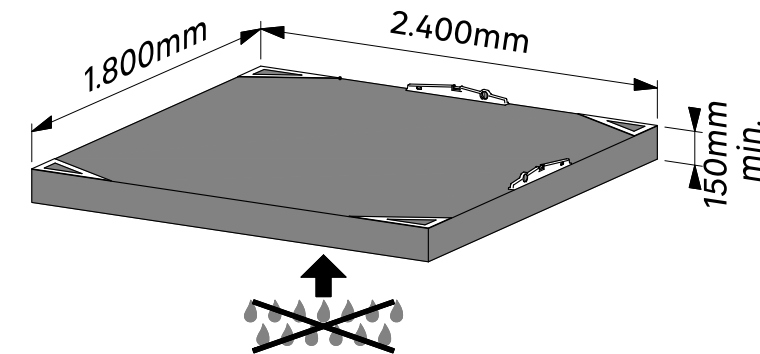
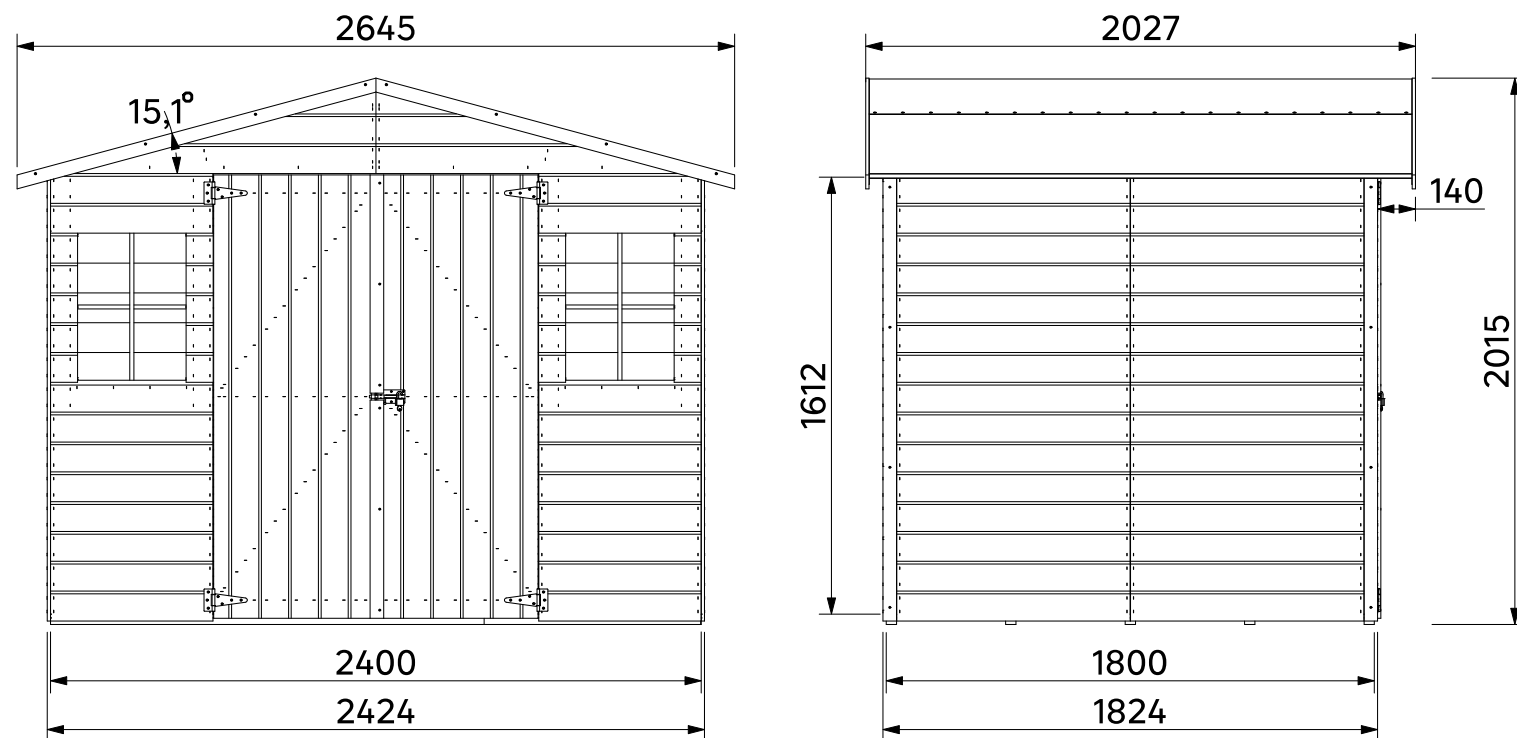

**FR** Sol nivelé requis.  
Pose sur dalle béton parfaitement plate et de niveau (non incluse).

**ES** Es necesario un suelo nivelado.  
Colocar sobre losa de hormigón perfectamente plana y nivelada (non incluida).

**PT** É necessário um solo nivelado.  
Montagem sobre laje de betão perfeitamente plana e nivelada (não incluído).

**IT** È richiesto un fondo livellato.  
Posare su pavimenti in cemento perfettamente in piano e livellato (non incluso).

**EL** Απαιτείται επίπεδο έδαφος.  
Πρέπει να τοποθετείται πάνω σε απόλυτα επίπεδη και οριζόντια πλάκα σκυροδέματος (δεν περιλαμβάνεται).

**PL** Wymagane wyrównanie i wypoziomowanie podłoża.  
Montaż na idealnie płaskiej i wypoziomowanej płycie betonowej (brak w zestawie).

**UA** Necesar teren plat.  
Montare pe dală de beton perfect plată și la nivel (nu este inclusă).

**RO** Necesar teren plat.  
Ukladanja na idealno rívnju i virivnjaju betonnu plitju (ne vchoditj u komplet).

**EN** Level ground required.  
Laying on a perfectly flat and level concrete slab (not included).

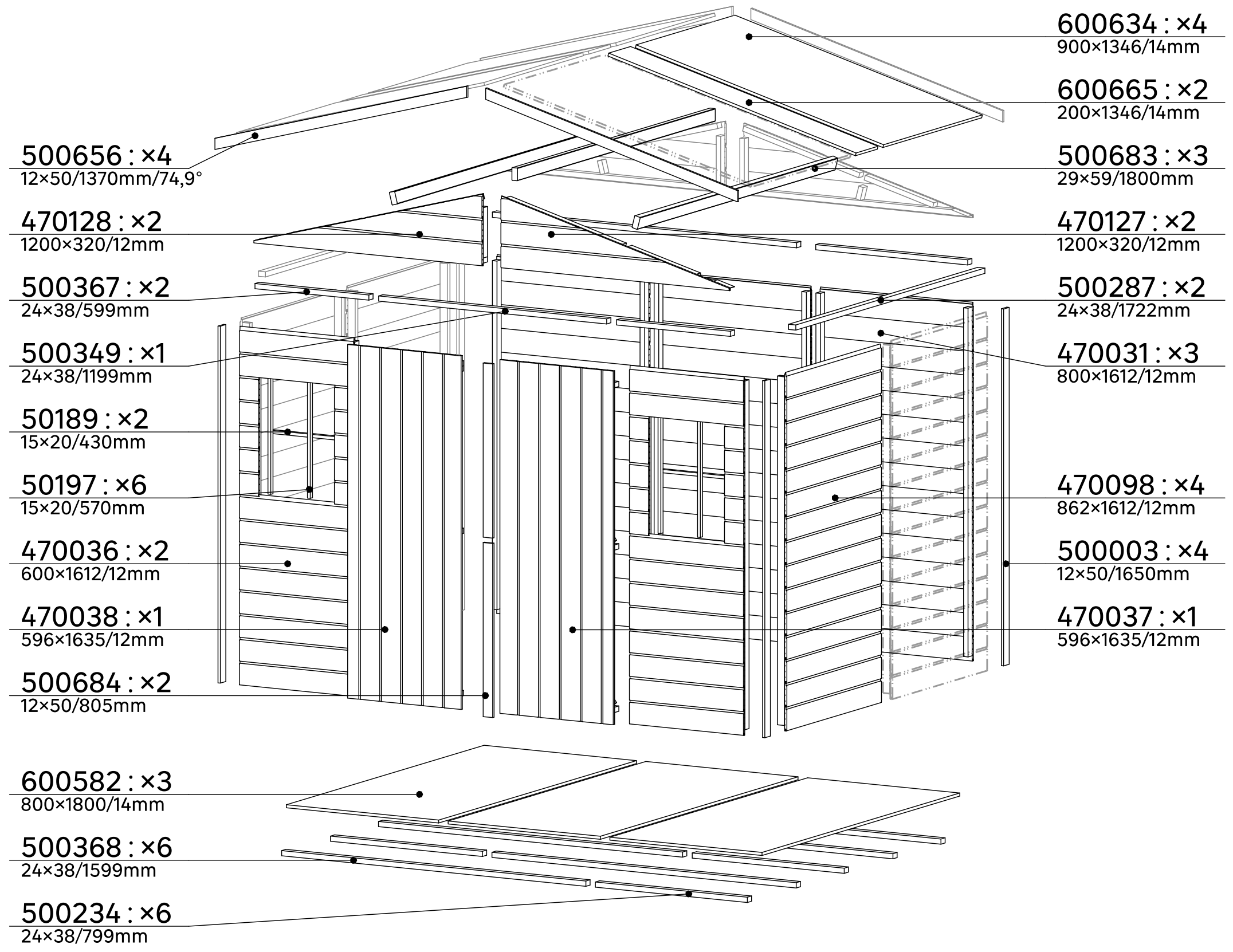

**500656 : x4**  
12x50/1370mm/74,9°

**470128 : x2**  
1200x320/12mm

**500367 : x2**  
24x38/599mm

**500349 : x1**  
24x38/1199mm

**50189 : x2**  
15x20/430mm

**50197 : x6**  
15x20/570mm

**470036 : x2**  
600x1612/12mm

**470038 : x1**  
596x1635/12mm

**500684 : x2**  
12x50/805mm

**600582 : x3**  
800x1800/14mm

**500368 : x6**  
24x38/1599mm

**500234 : x6**  
24x38/799mm

**600634 : x4**  
900x1346/14mm

**600665 : x2**  
200x1346/14mm

**500683 : x3**  
29x59/1800mm

**470127 : x2**  
1200x320/12mm

**500287 : x2**  
24x38/1722mm

**470031 : x3**  
800x1612/12mm

**470098 : x4**  
862x1612/12mm

**500003 : x4**  
12x50/1650mm

**470037 : x1**  
596x1635/12mm

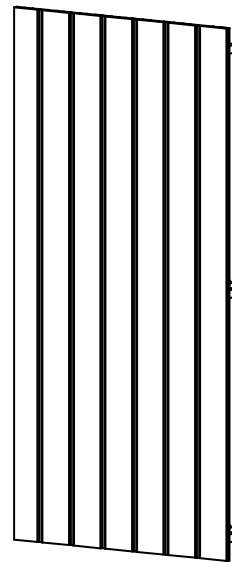
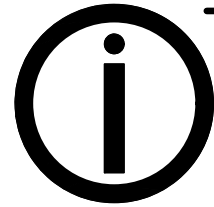

470037 → : 1  
596×1635/12mm  
470038 ← : 1  
596×1635/12mm

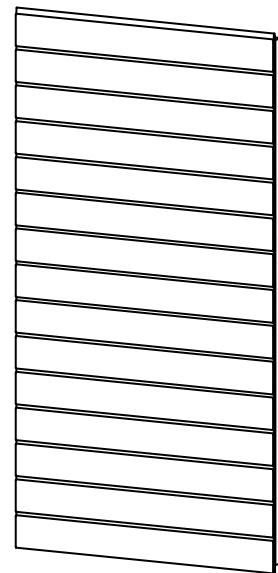

470031 : 3  
800 × 1612 / 12mm  
470098 : 4  
862 × 1612 / 12mm

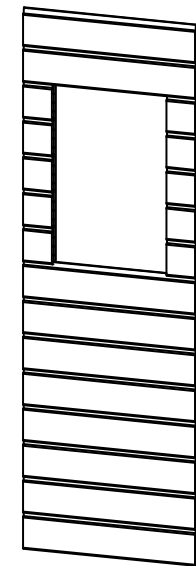

470036 : 2  
600 × 1612 / 12mm

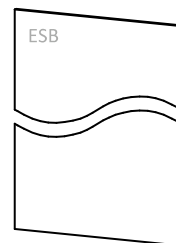

600665 : 2  
200 × 1346 / 14mm  
600582 : 3  
800 × 1800 / 14mm  
600634 : 4  
900 × 1346 / 14mm



470128 : 2  
1200 × 320 / 12mm

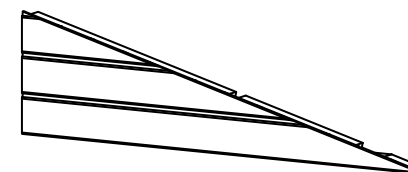

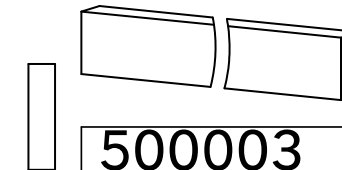

470127 : 2  
1200 × 320 / 12mm





500003 : 4  
12×50/1650mm  
500684 : 2  
12×50/805mm  
50189 : 2  
15×20/430mm  
50197 : 6  
15×20/570mm  
500349 : 1  
24×38/1199mm  
500368 : 6  
24×38/1599mm  
500287 : 2  
24×38/1722mm  
500367 : 2  
24×38/599mm  
500234 : 6  
24×38/799mm  
500683 : 3  
29×59/1800mm

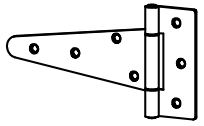
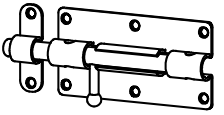
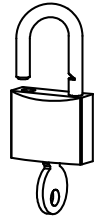

500656 : 4  
12×50/1370mm/74,9°

<b>Kit 700394</b>			
	3009	∅3,5×12mm	16
	3012	∅3,5×25mm	22
	3014	∅3,5×35mm	65
	3023	∅4×40mm	128
	3025	∅4×50mm	16
	3027	∅4×60mm	60
<b>Kit 700043</b>			
	3810	∅2×15mm	90
<b>Plexy</b>			
	750010	425×570/1,2mm	2

<b>Kit 700275</b>					
	2013	4		2155	2
	2181	1			
	2915	∅4mm			1

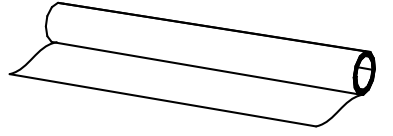
	1,5mm		
800003	1,00×6,60m		1

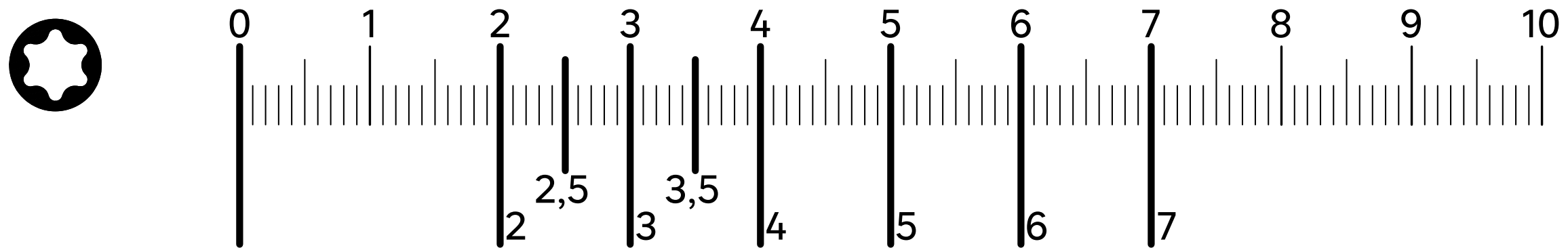

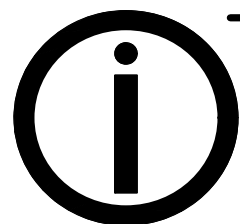

**FR** Technique pour assembler les panneaux, en les vissant entre-eux.

**ES** Técnica para ensamblar los paneles atornillándolos entre sí.

**PT** Técnica para a montagem de painéis aparafusando uns aos outros.

**IT** Tecnica per assemblare i pannelli, avvitandoli tra loro.

**EL** Τεχνική συναρμολόγησης πάνελ βιδώνοντάς τα μεταξύ τους.

**PL** Technika montażu paneli poprzez skręcanie ich ze sobą

**UA** Техніка монтажу панелей шляхом скріплення їх між собою гвинтами.

**RO** Tehnică pentru asamblarea panourilor, prin înșurubare între ele.

**EN** Technique for assembling panels by screwing them together.

1

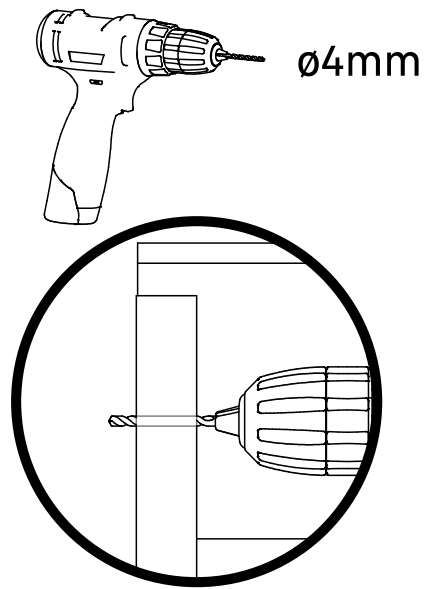
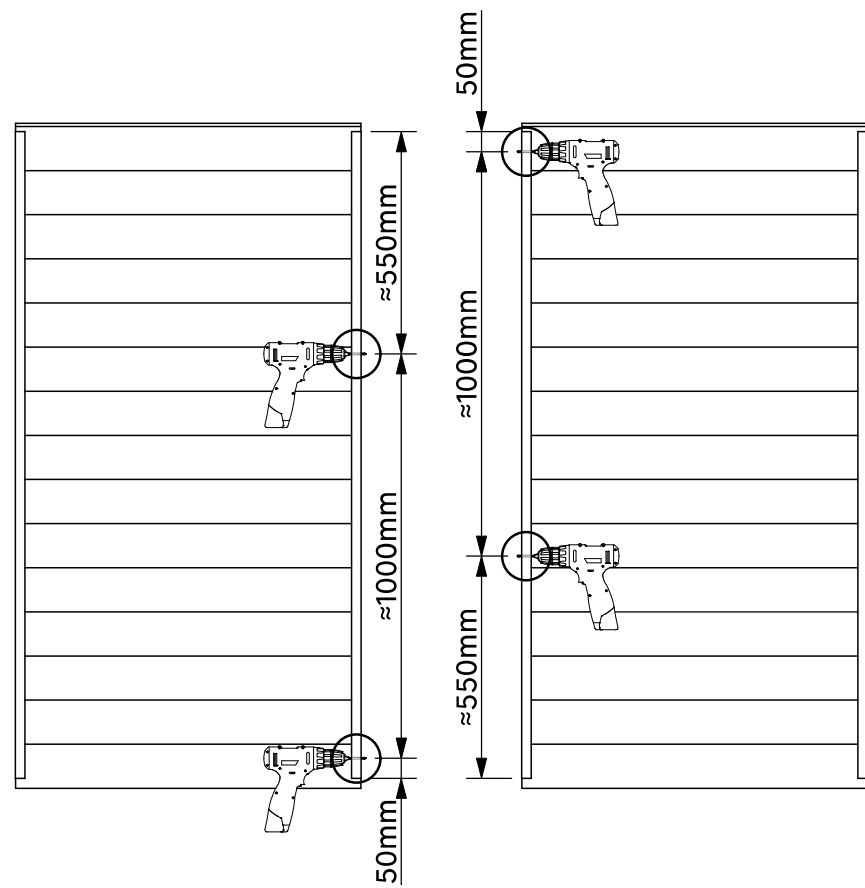

2

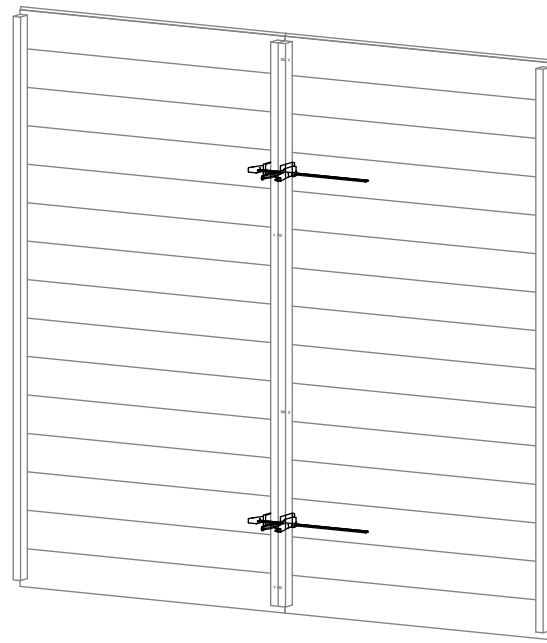

3

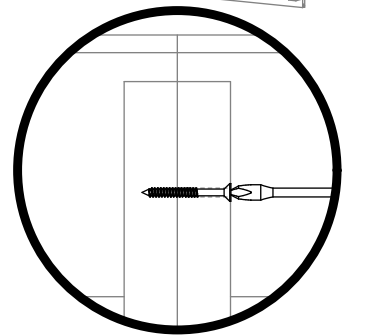
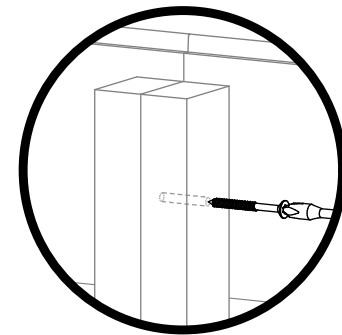
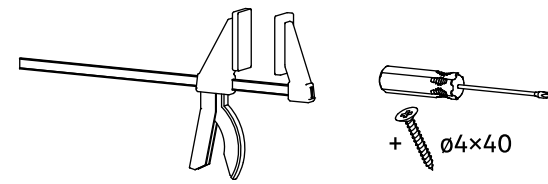



1

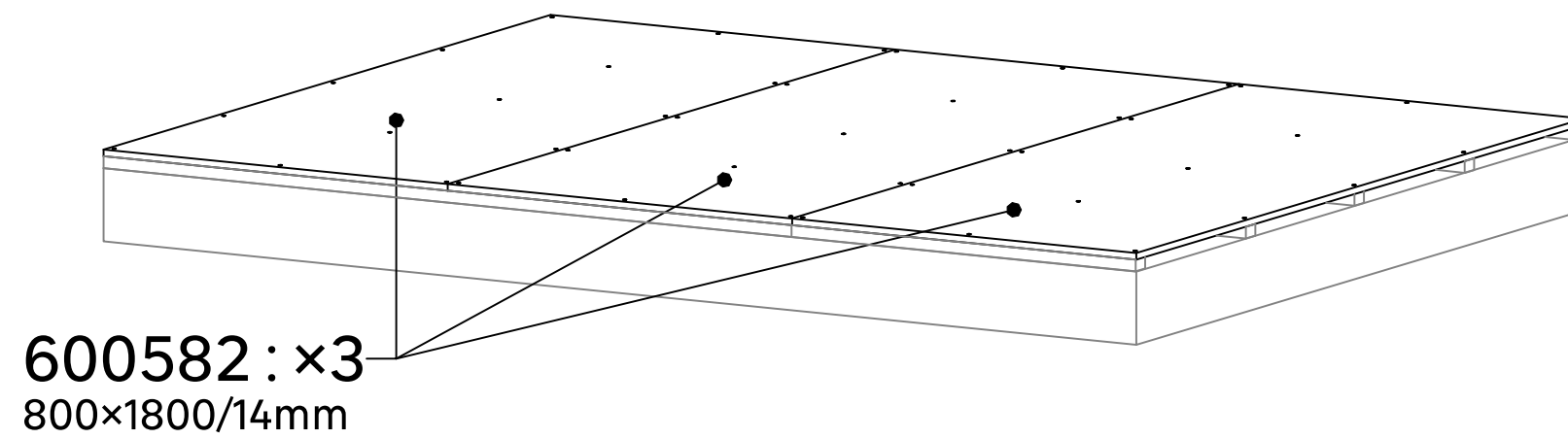
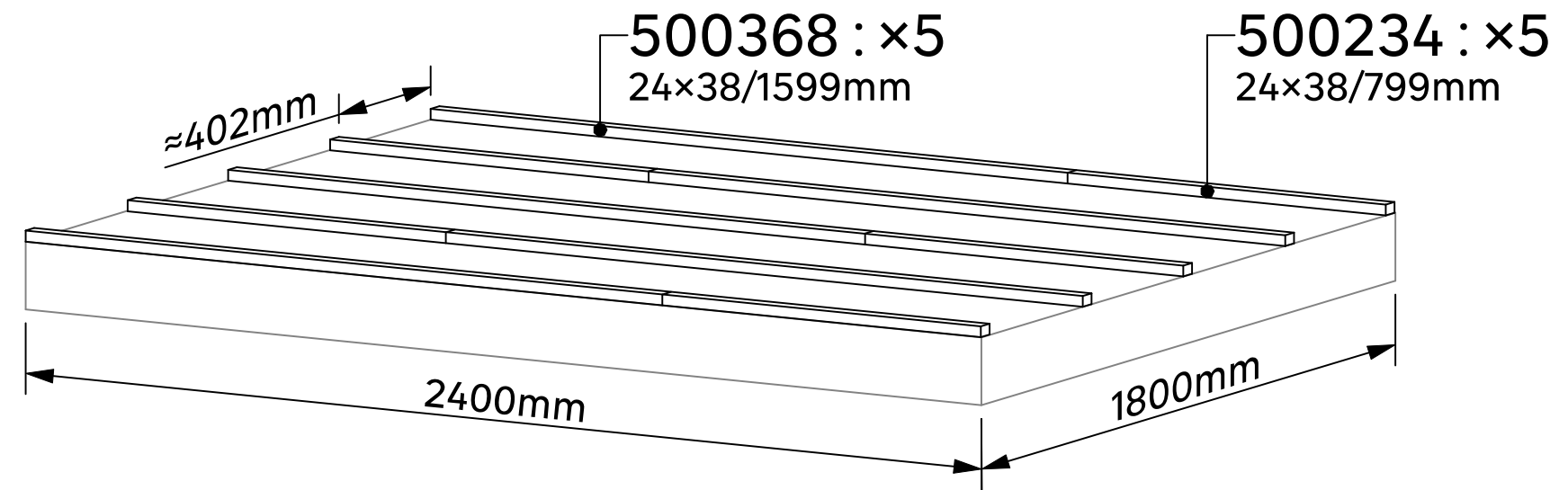

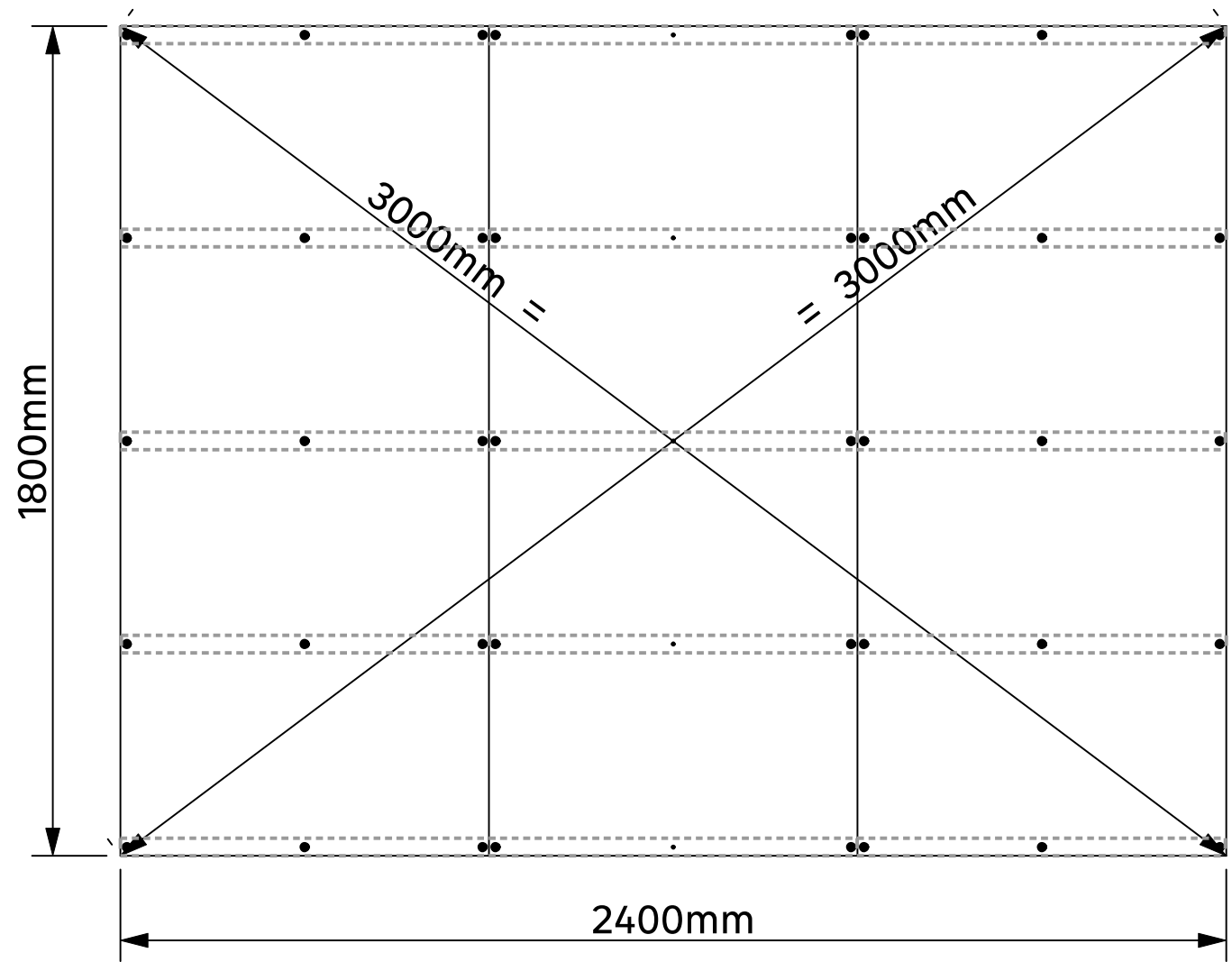

# 2



## 2.1

A=

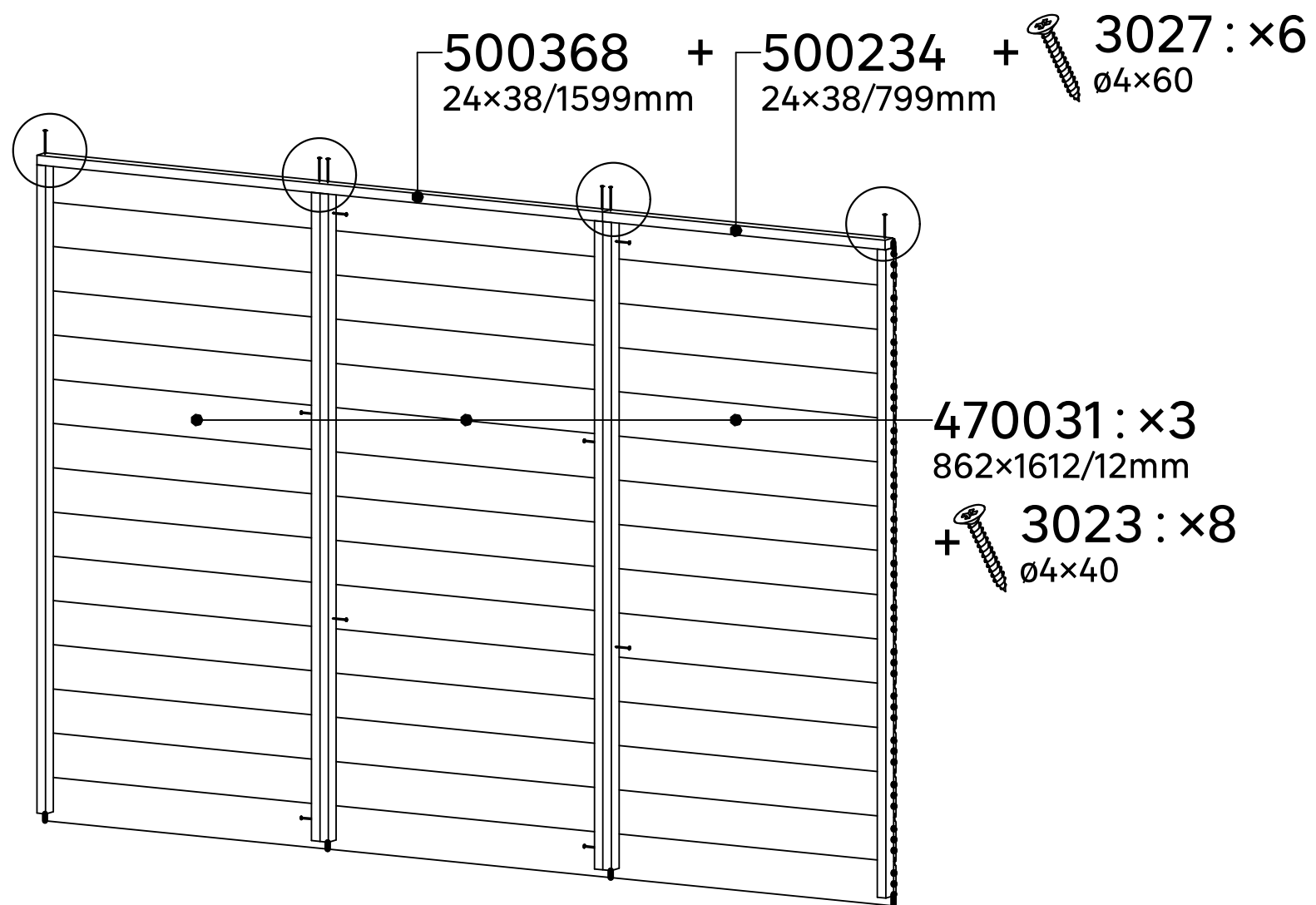

1

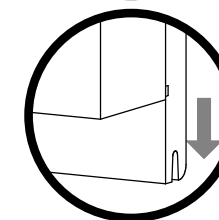
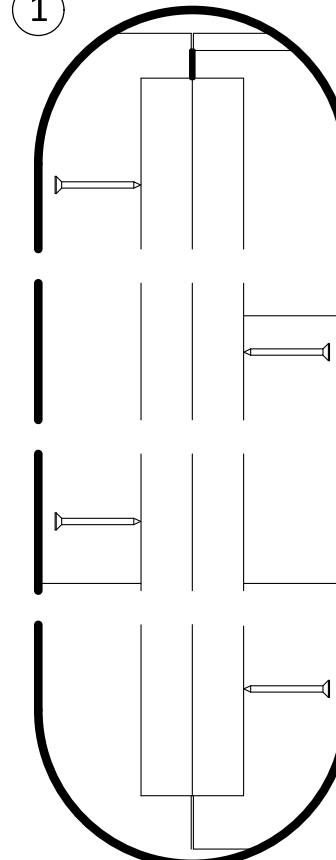

2

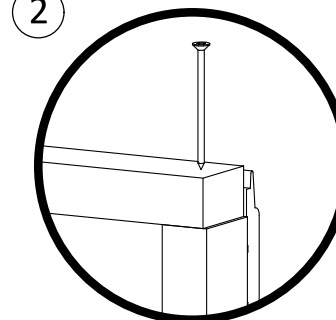

# 2.2

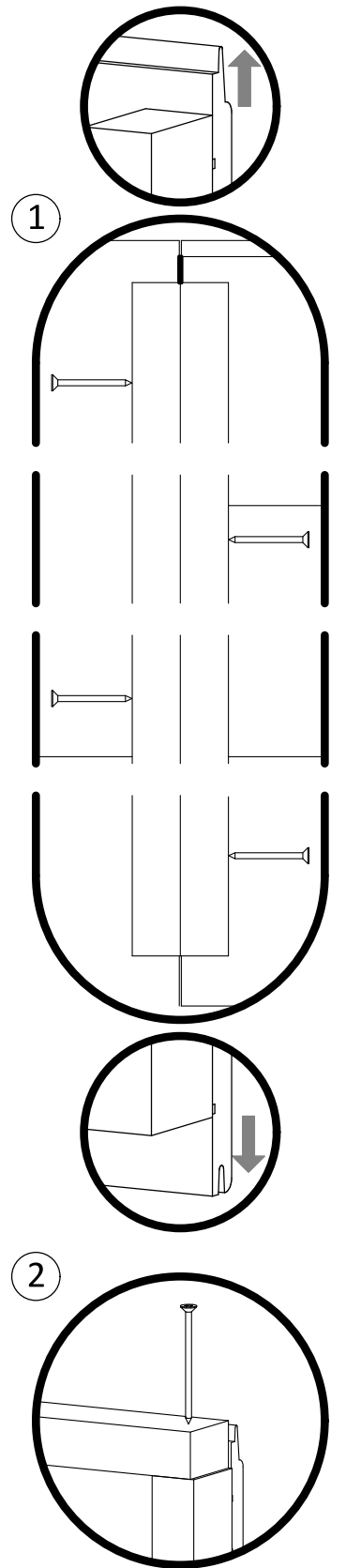
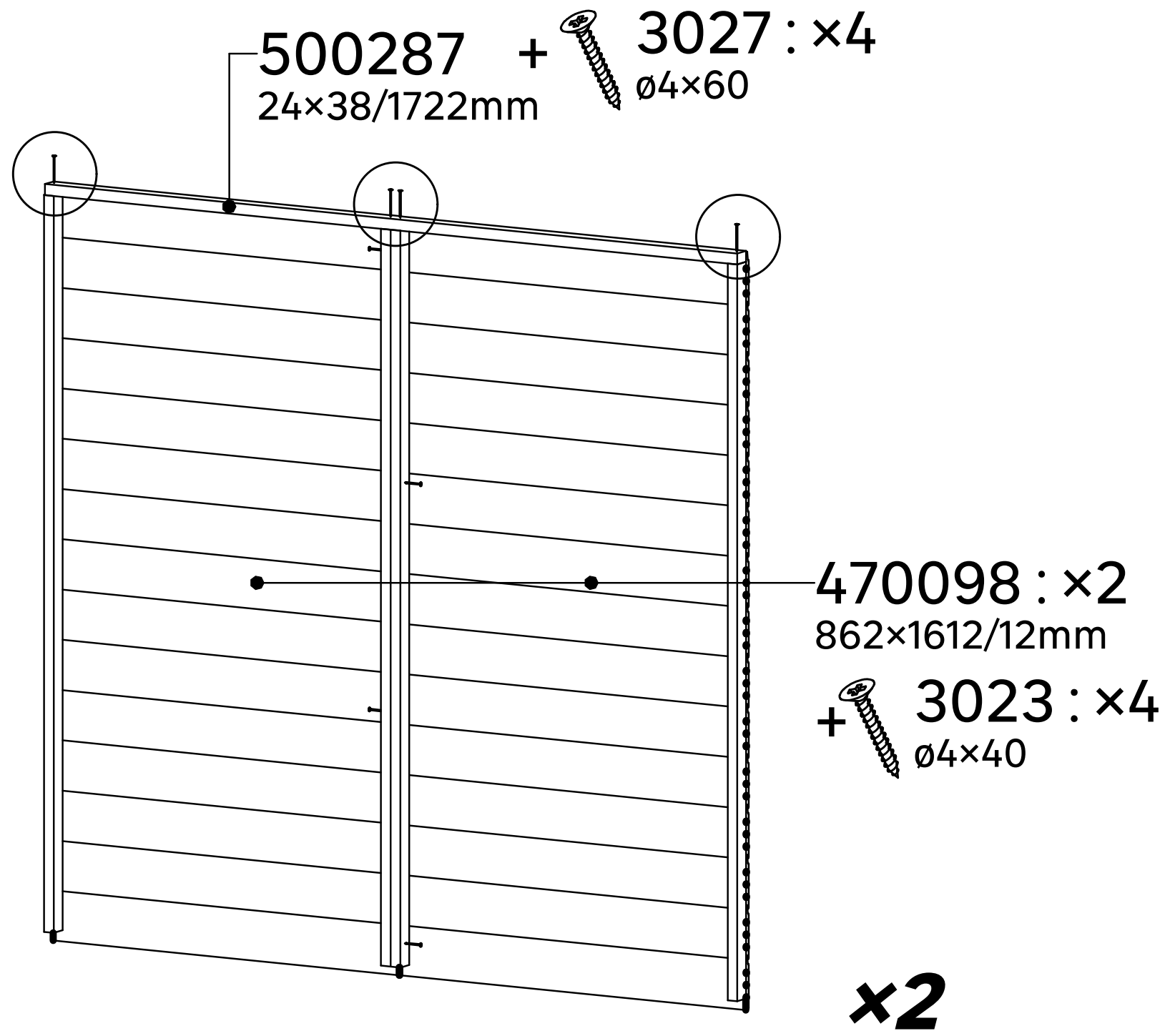
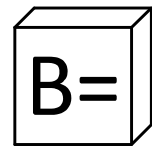

# 2.3

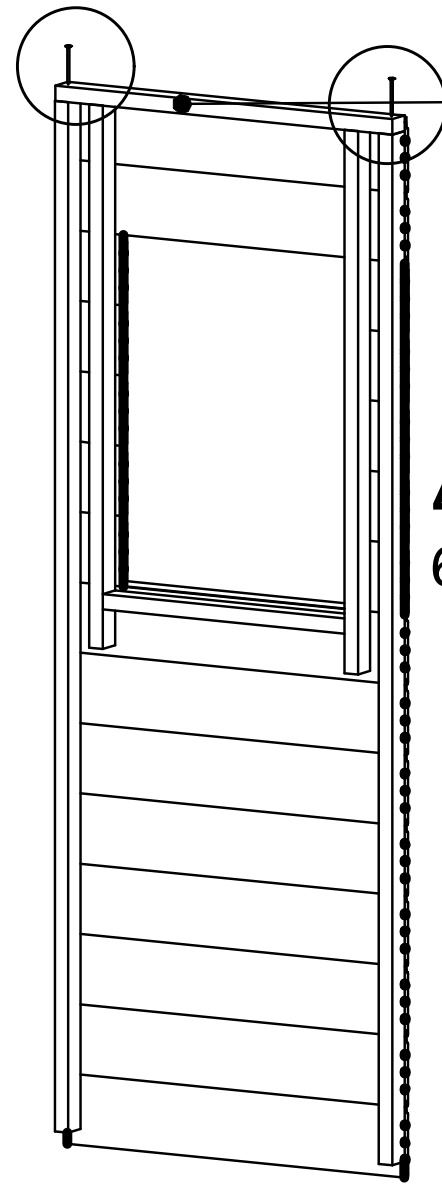
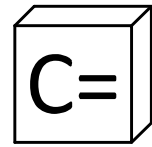

500367 +  
24x38/599mm



3027 : x2  
ø4x60

470036  
600x1612/12mm

x2

**3**

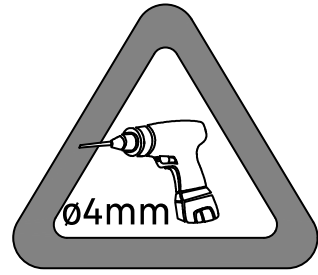

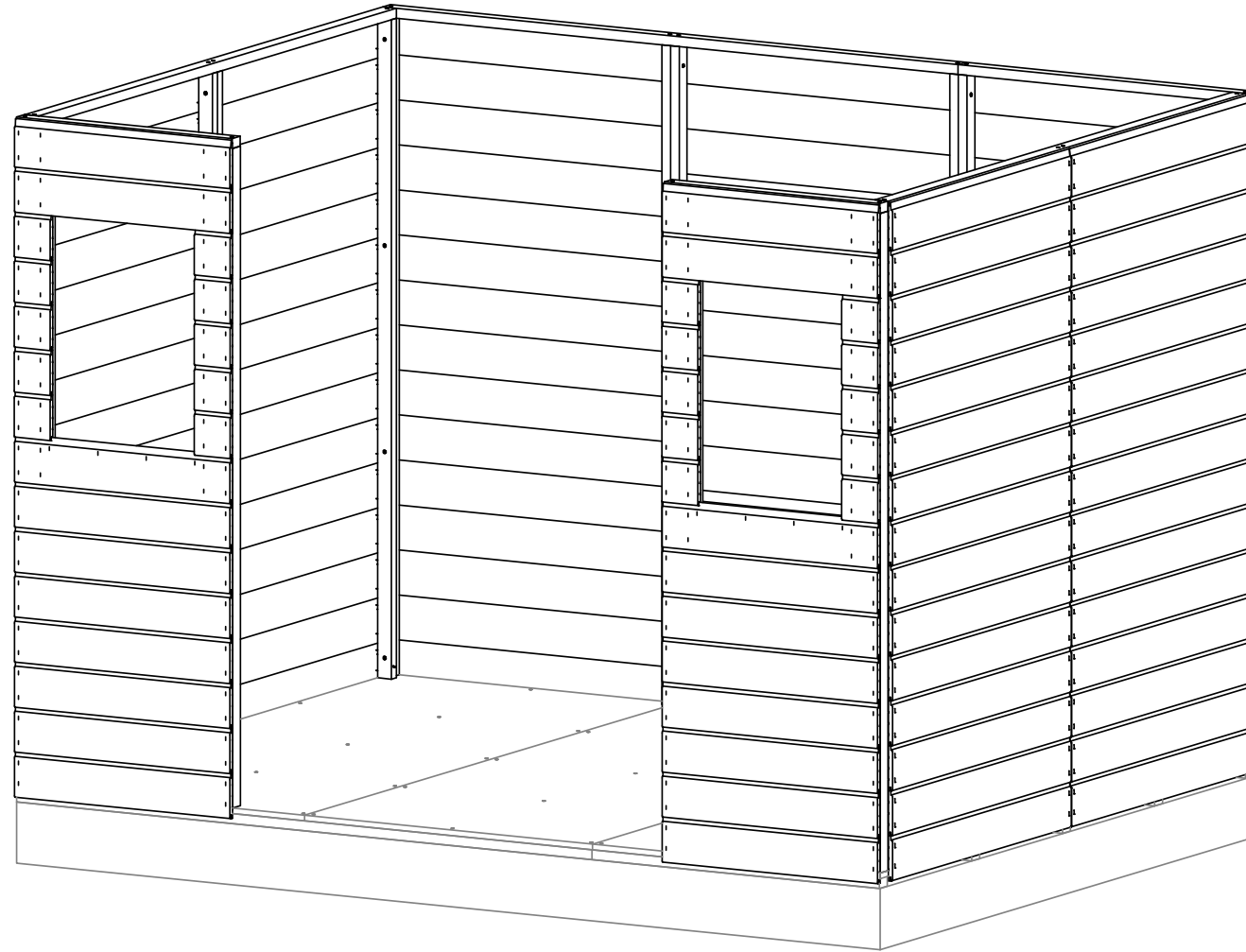

**3.1**

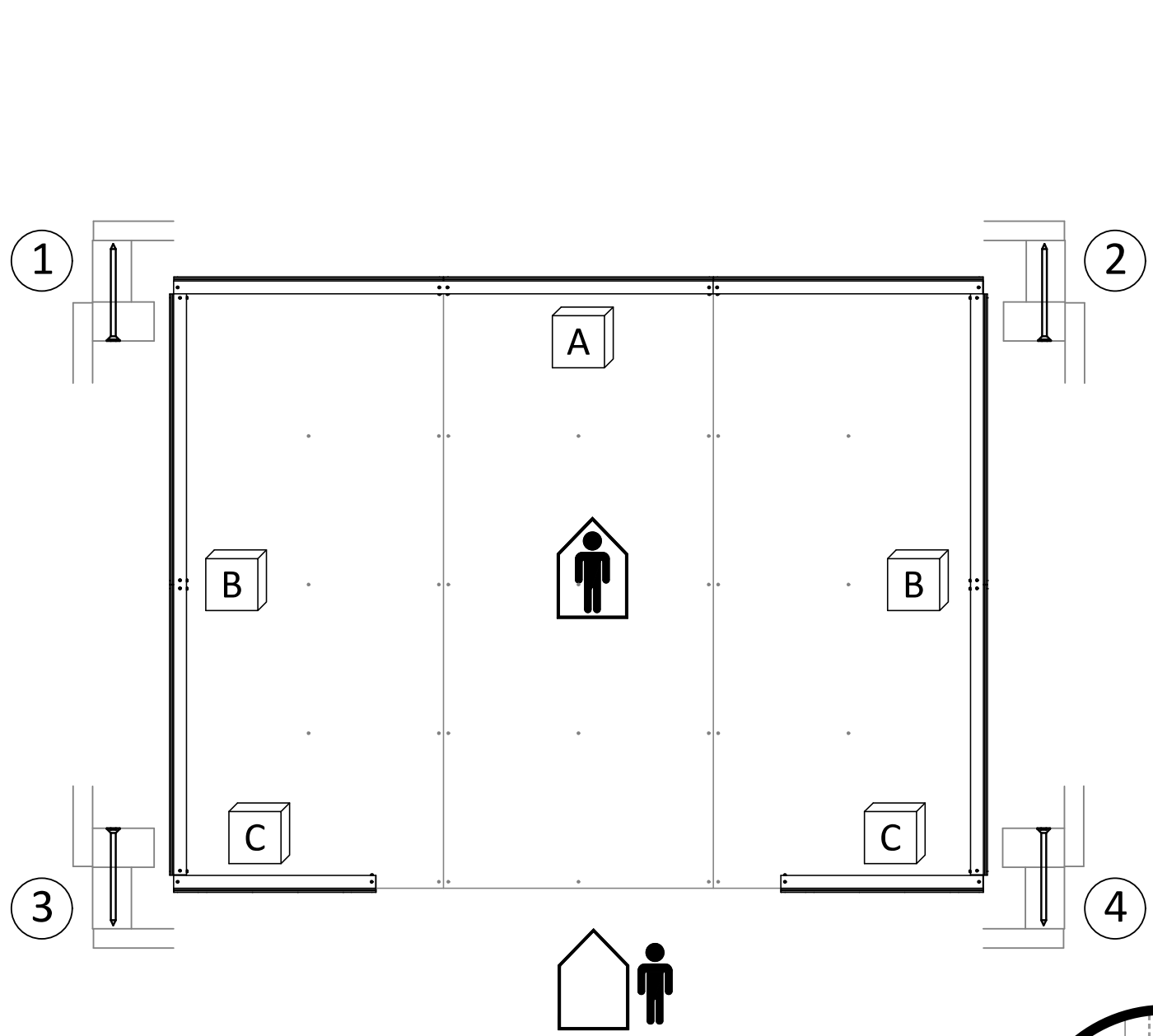



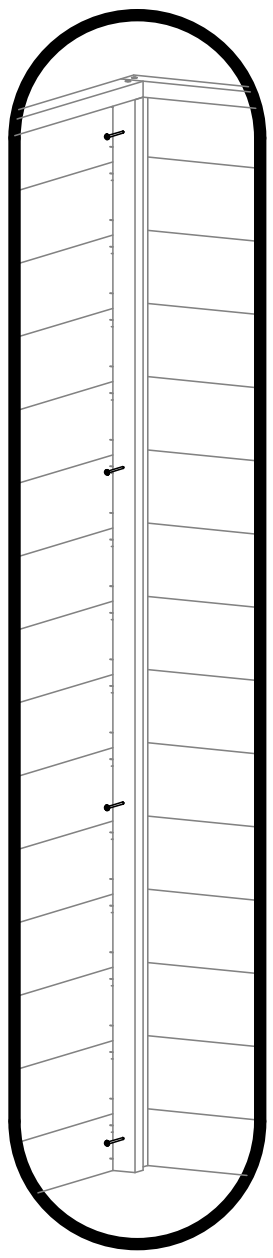
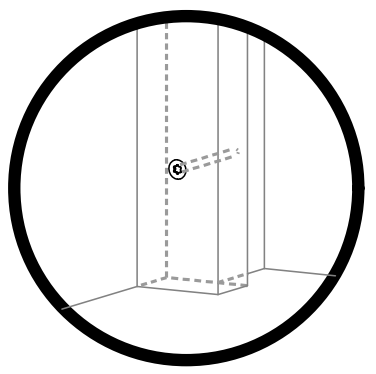

- ①    ②
  - ③    ④
- = x4

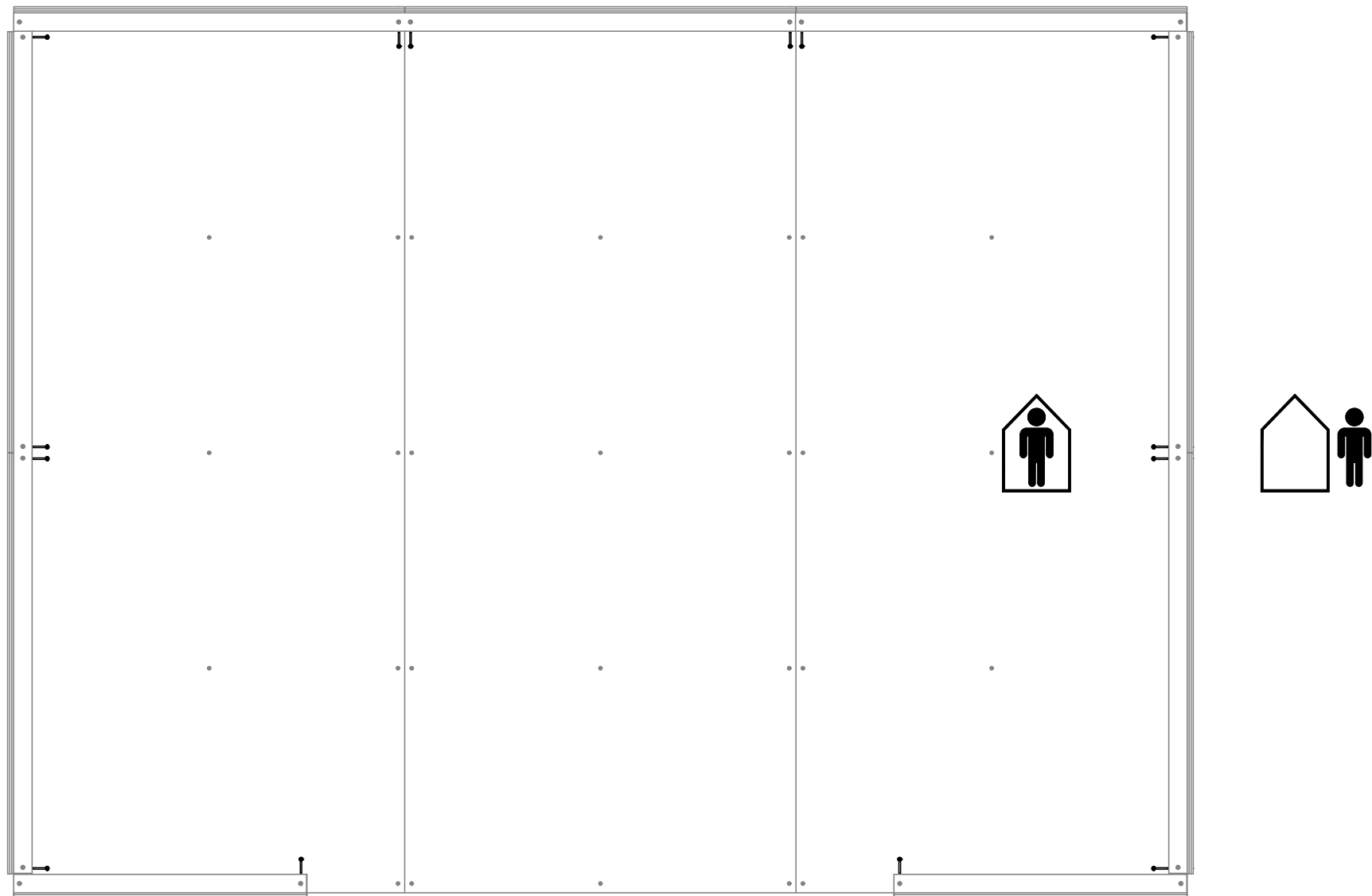

 3025 : x4  
 Ø4x50

# 3.2



 3027 : ×14  
Ø4×60



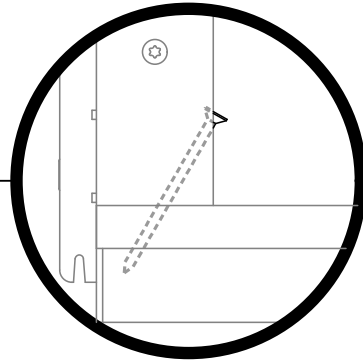
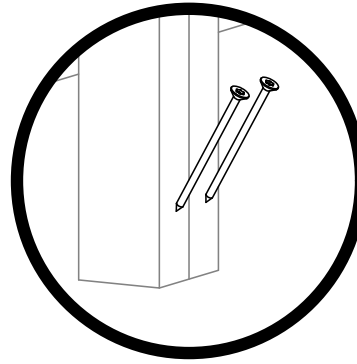
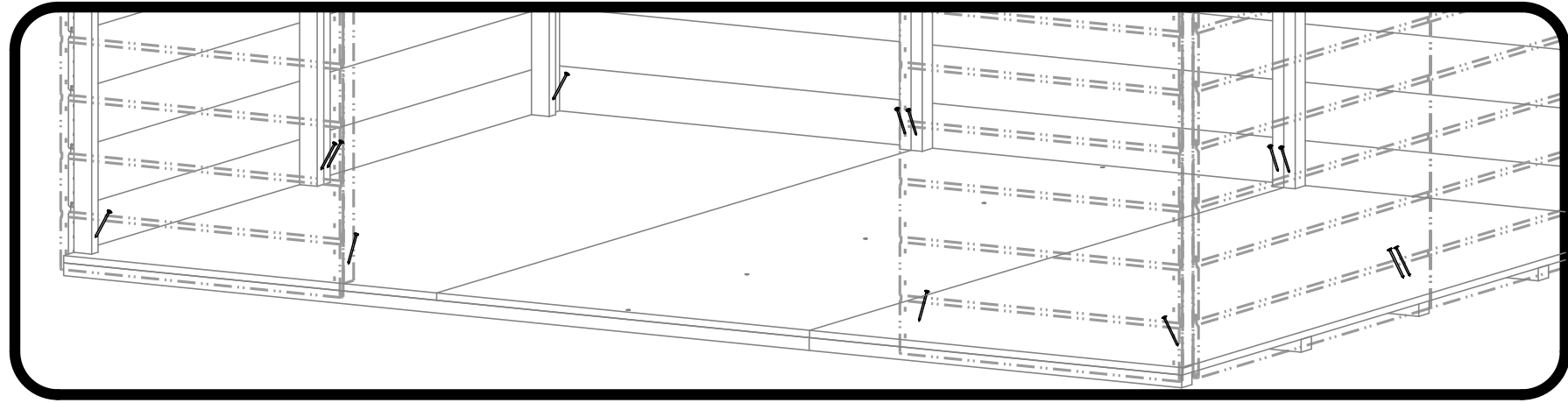

4

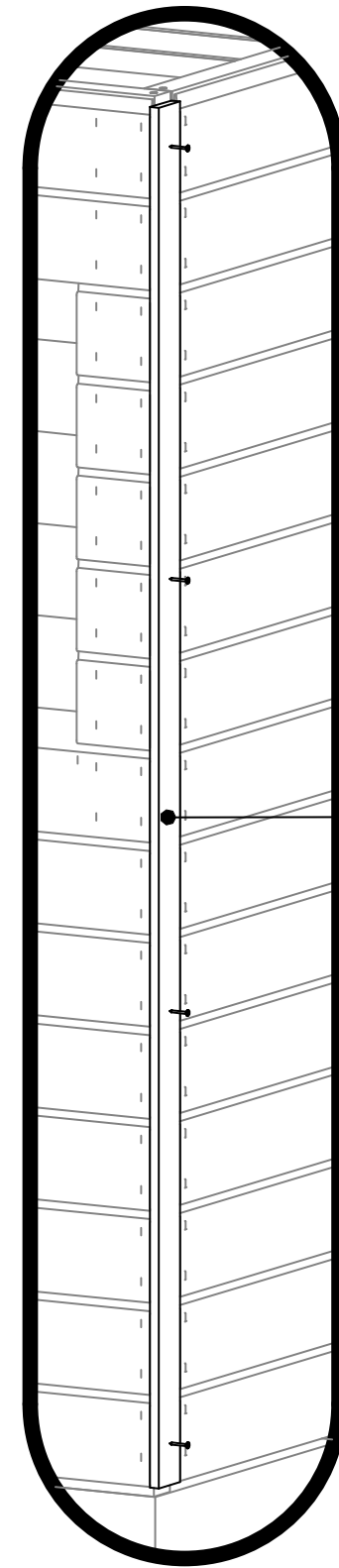
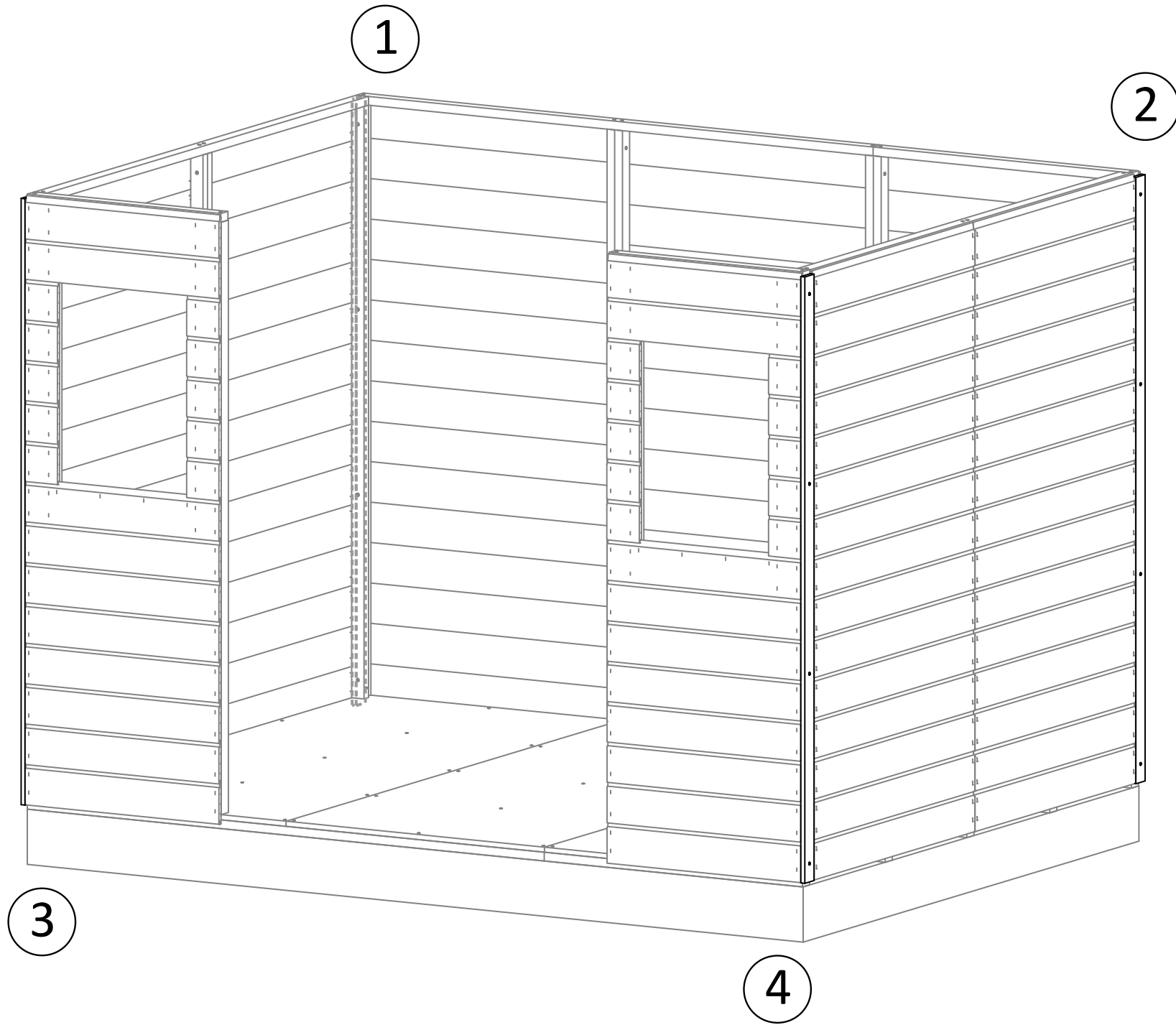

- 1
- 2
- 3
- 4

500003  
12×50/1650mm

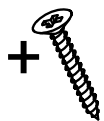
+  3012 : ×4  
ø3,5×25

×4

5

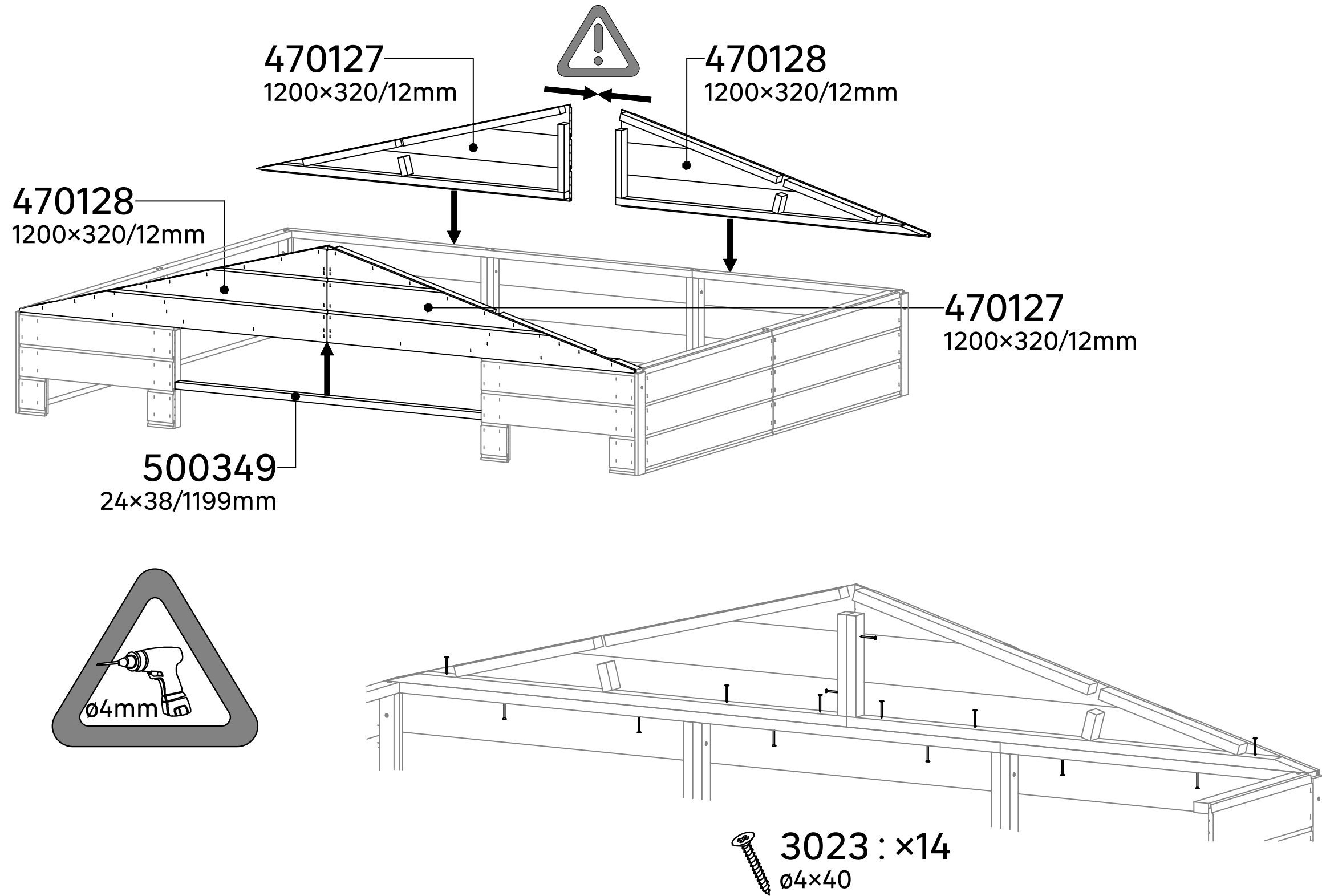

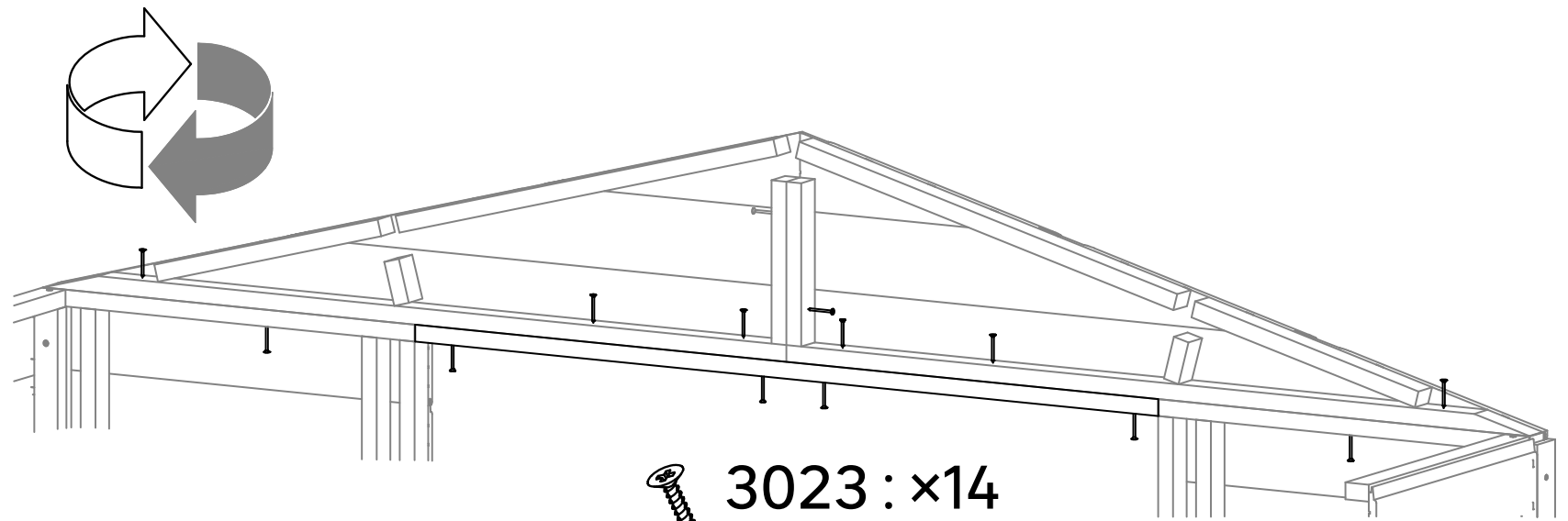

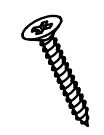
 **3023 : x14**  
**Ø4x40**

6

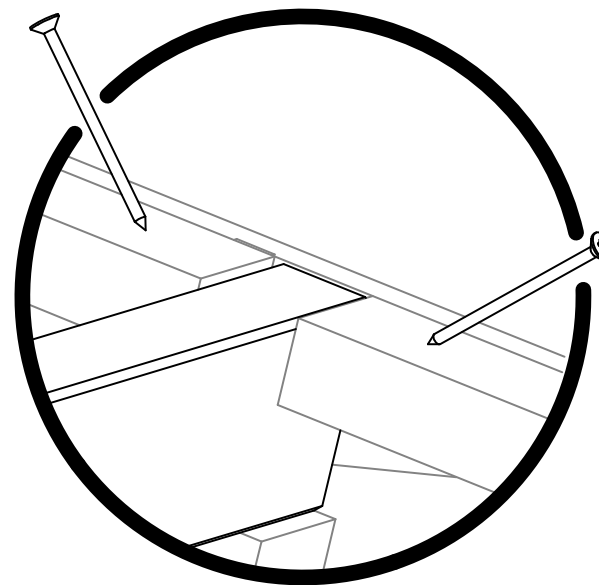
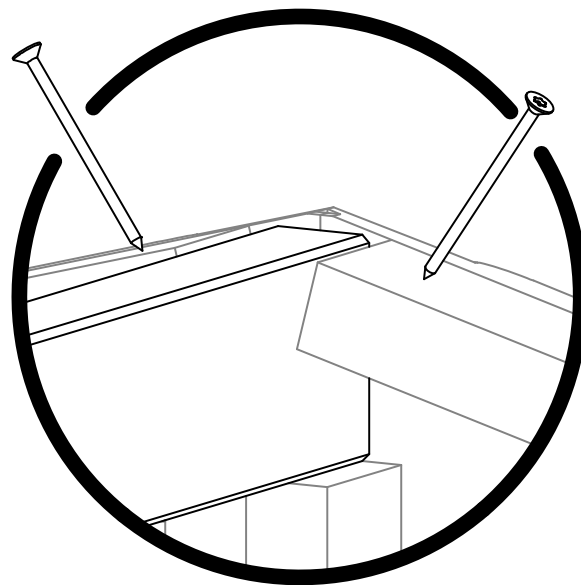
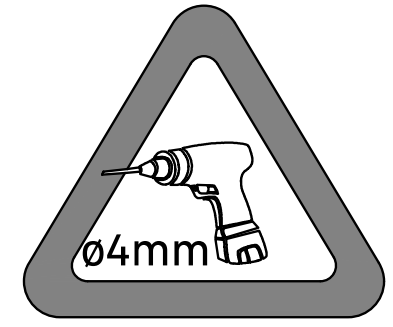
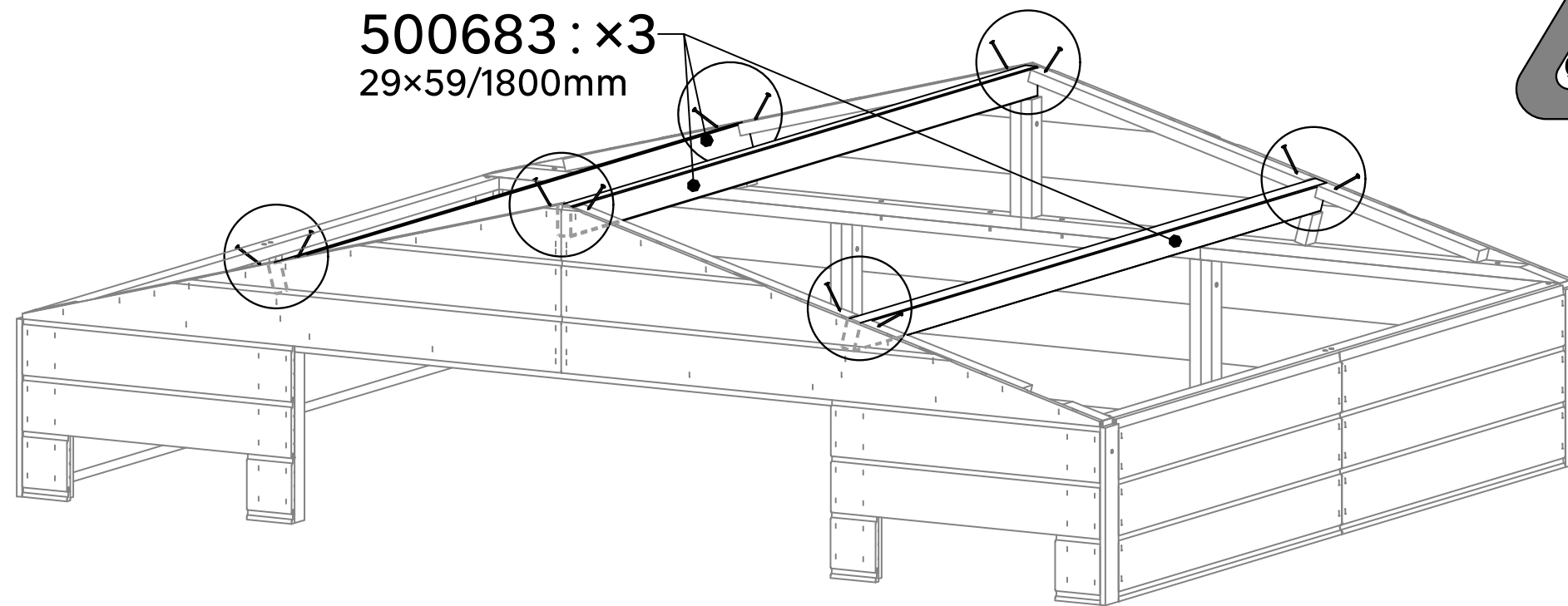



3027 : ×2  
Ø4×60  
×6

The text specifies the screw part number 3027, quantity ×2, dimensions Ø4×60, and a total quantity of ×6 for all slats.

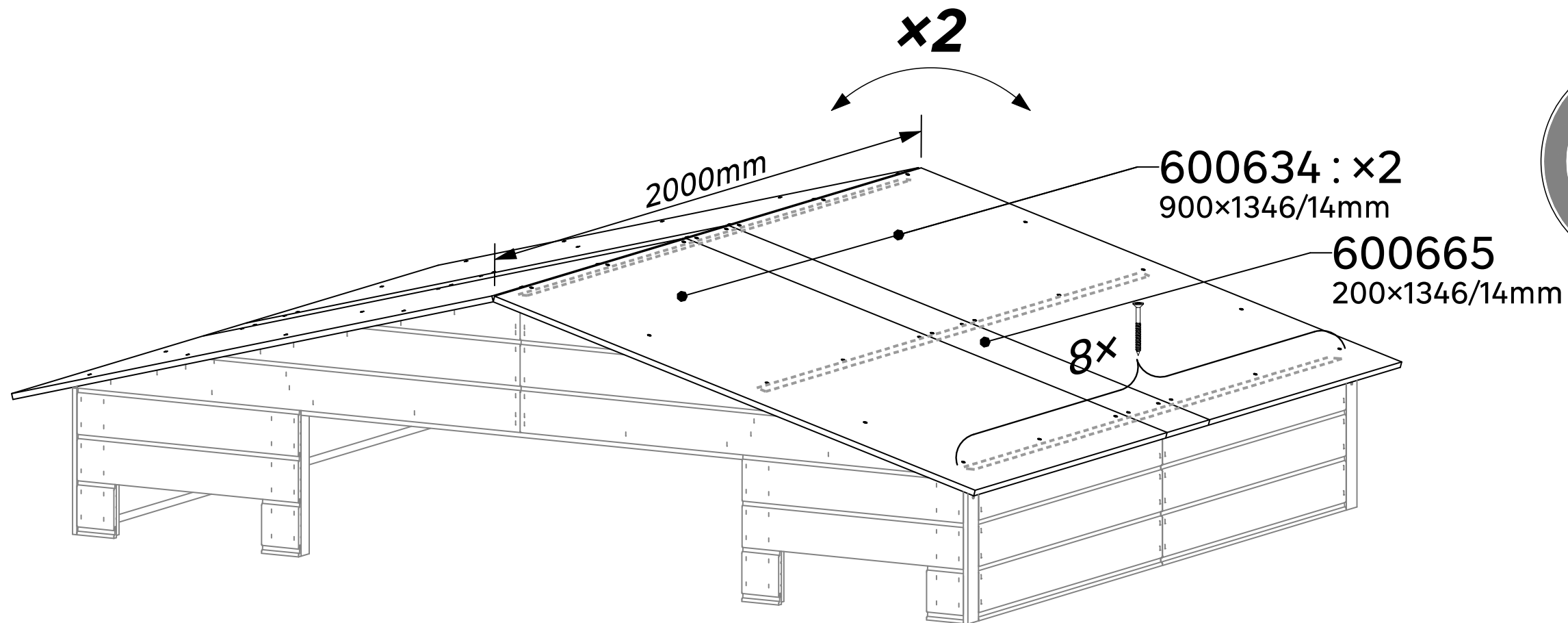
7

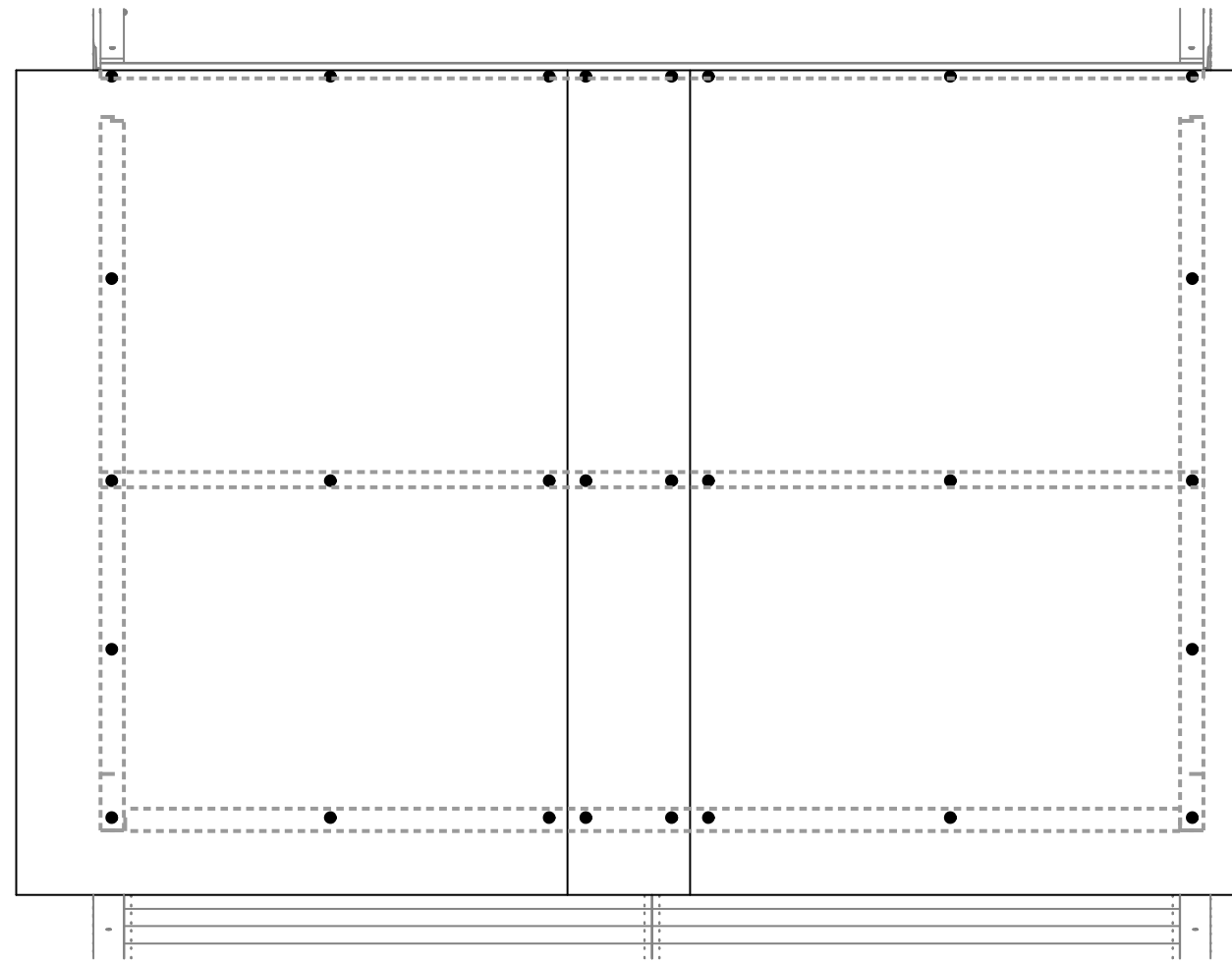
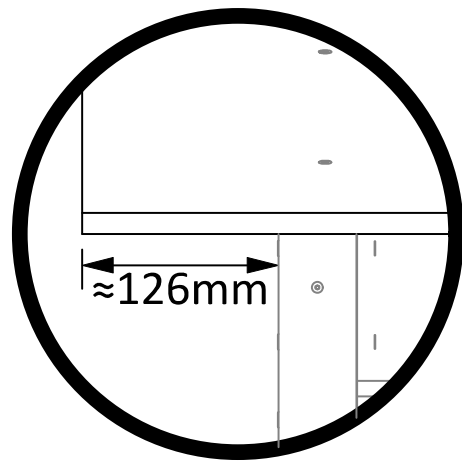



 3023 : x28  
 $\varnothing 4 \times 40$

**x2**

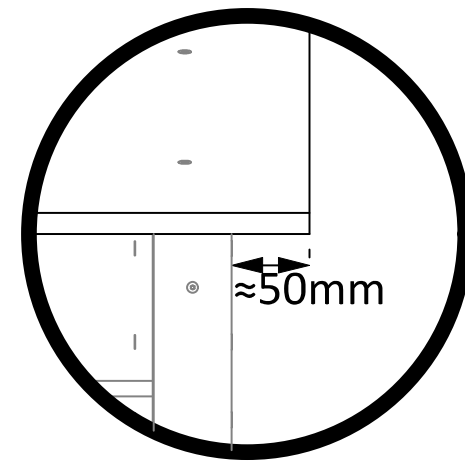

8

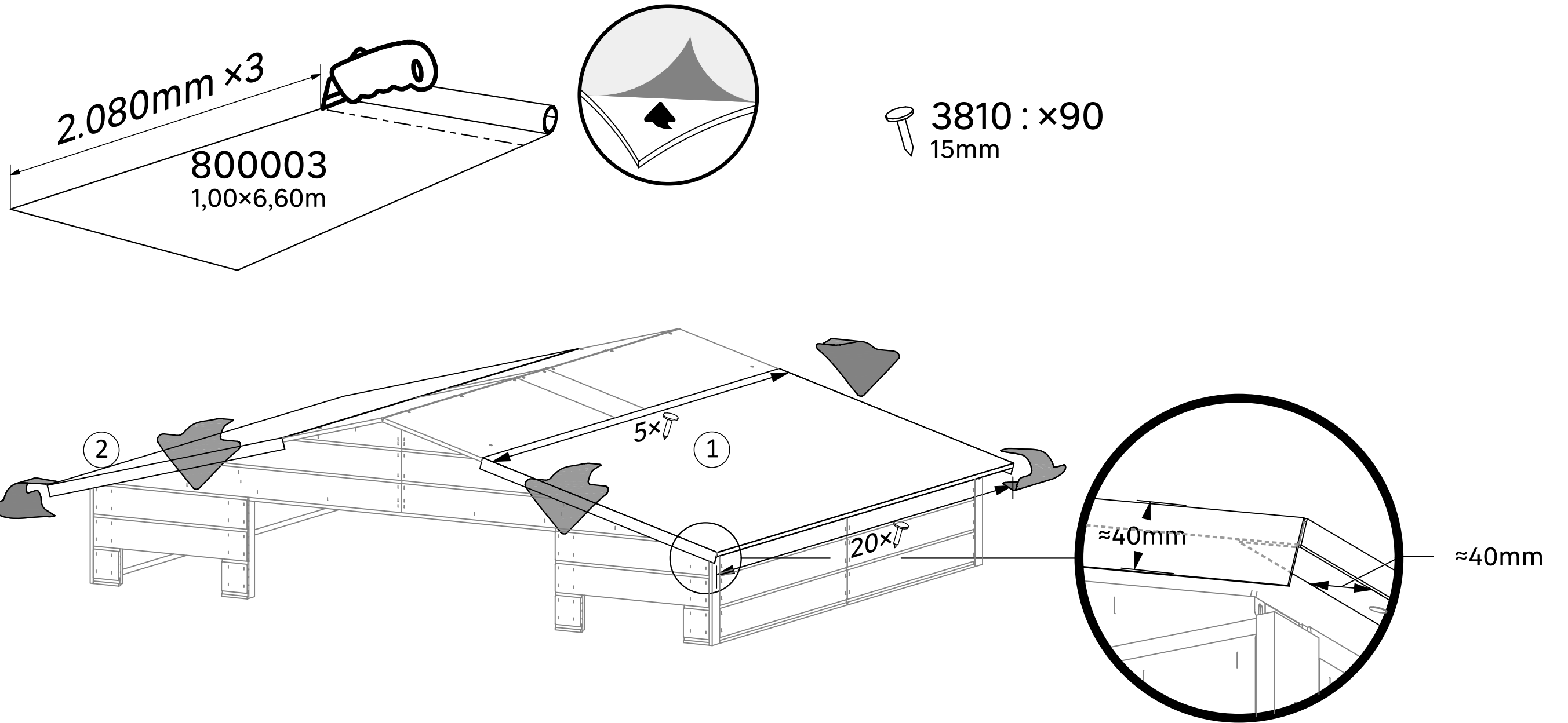



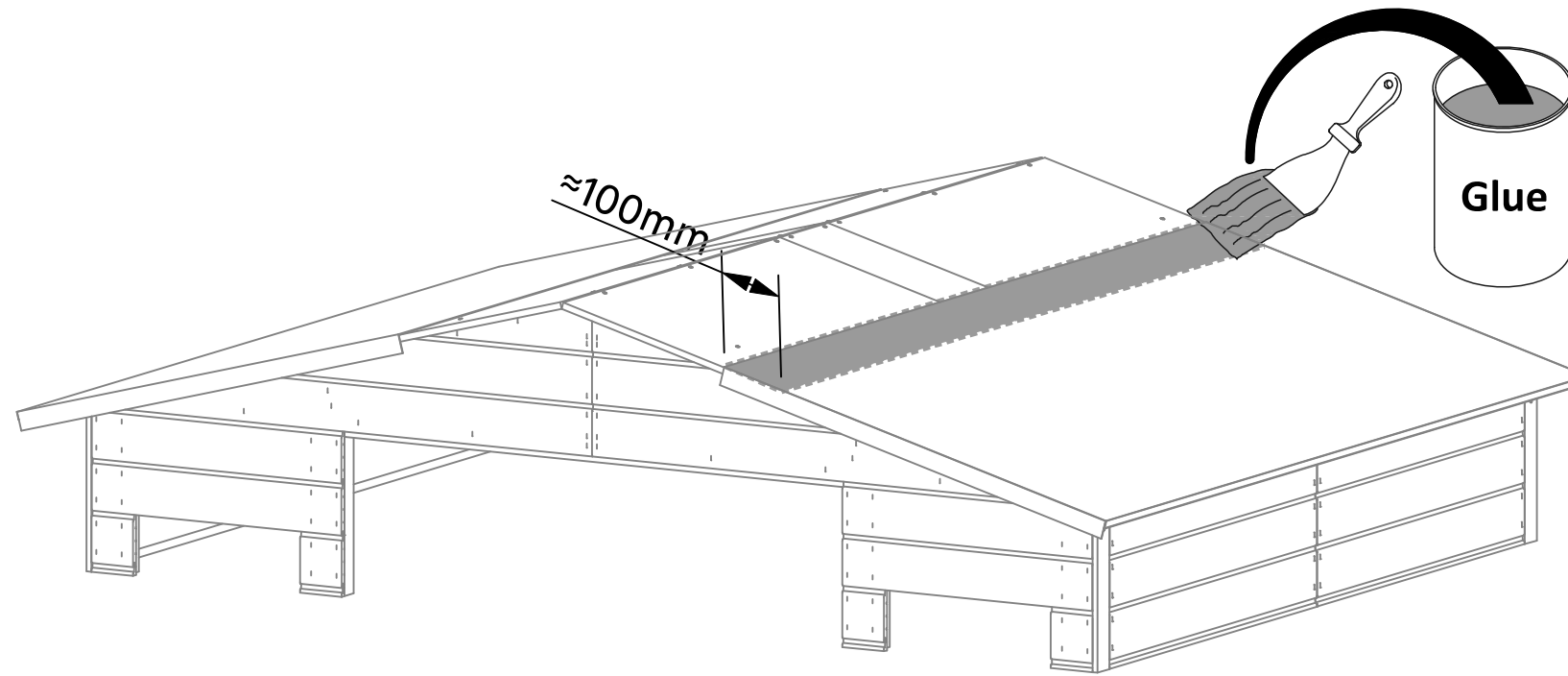

<b>FR</b> non incluse	<b>ES</b> non incluida	<b>PT</b> não incluído
<b>IT</b> non incluso	<b>EL</b> δεν περιλαμβάνεται	<b>PL</b> brak w zestawie
<b>UA</b> не входит у комплект	<b>RO</b> element neinclus	<b>EN</b> not included

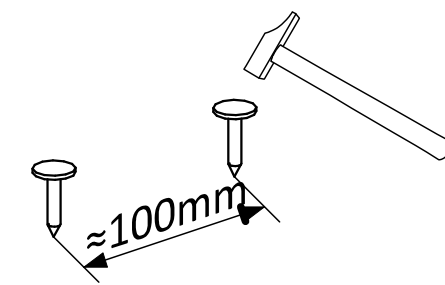
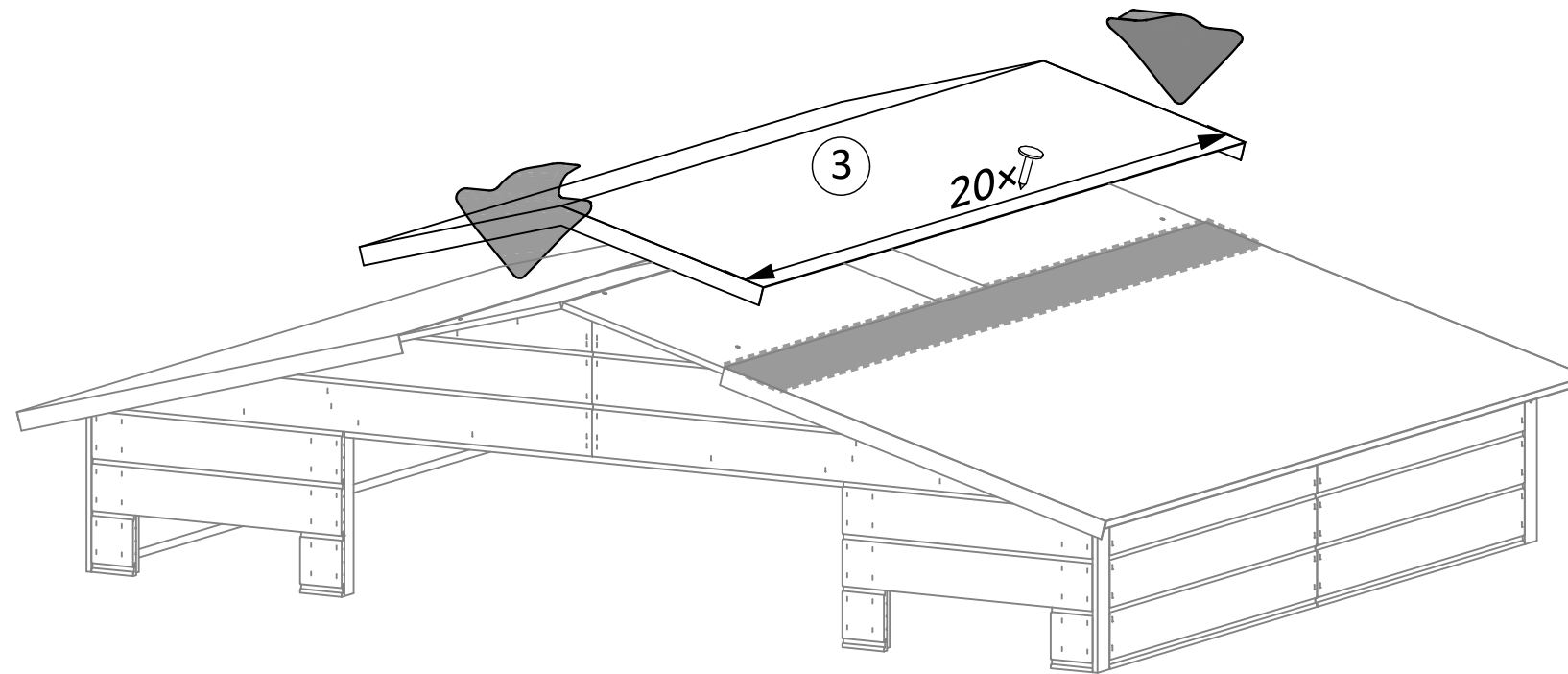

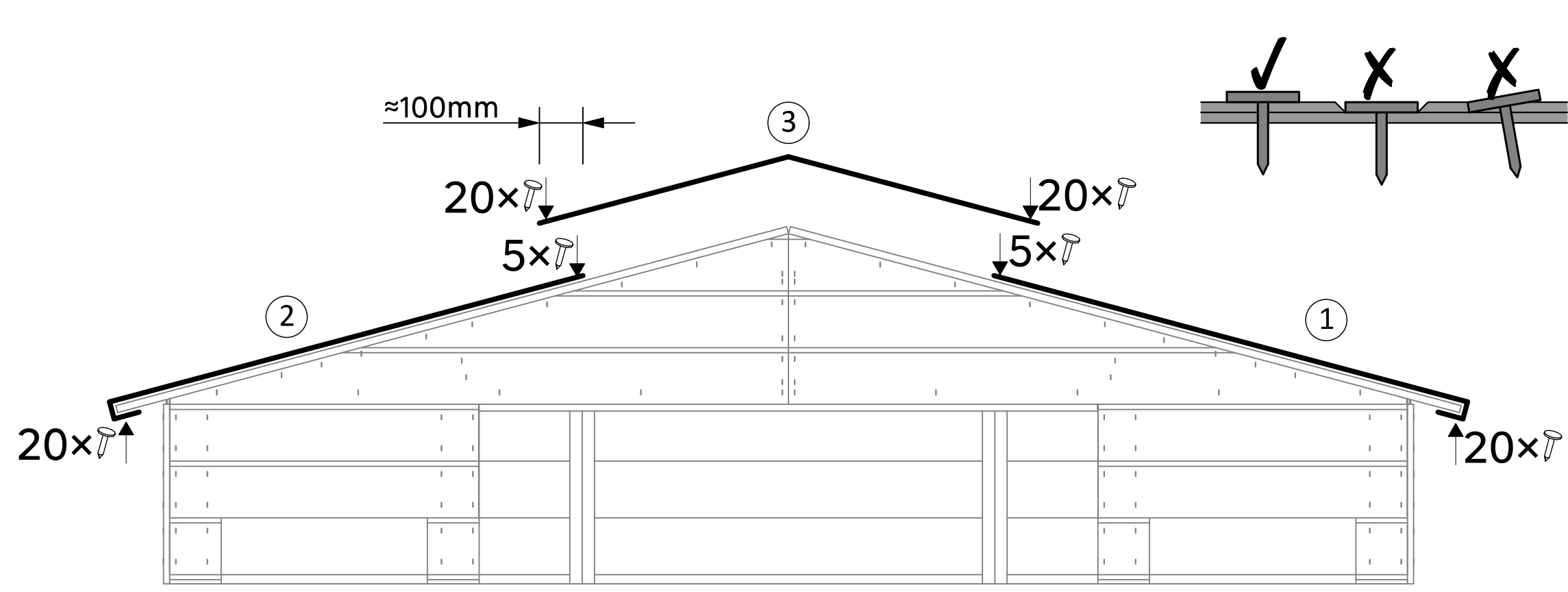

9

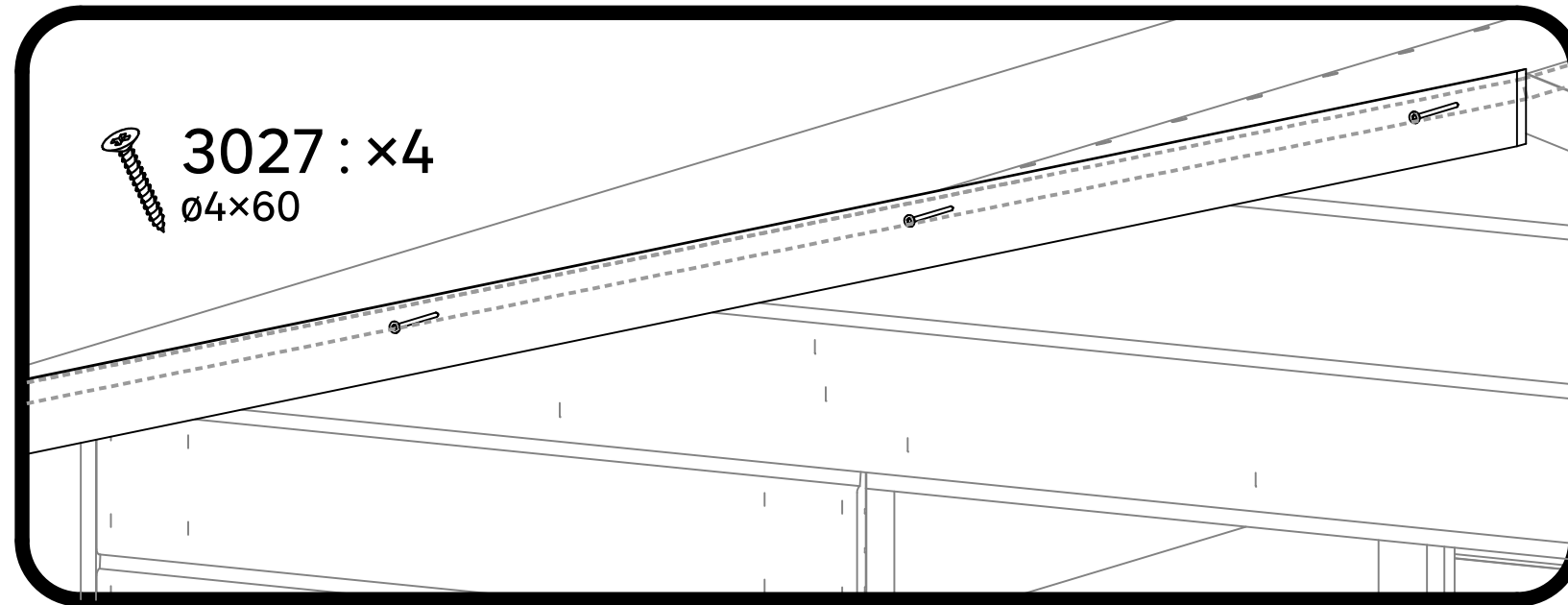
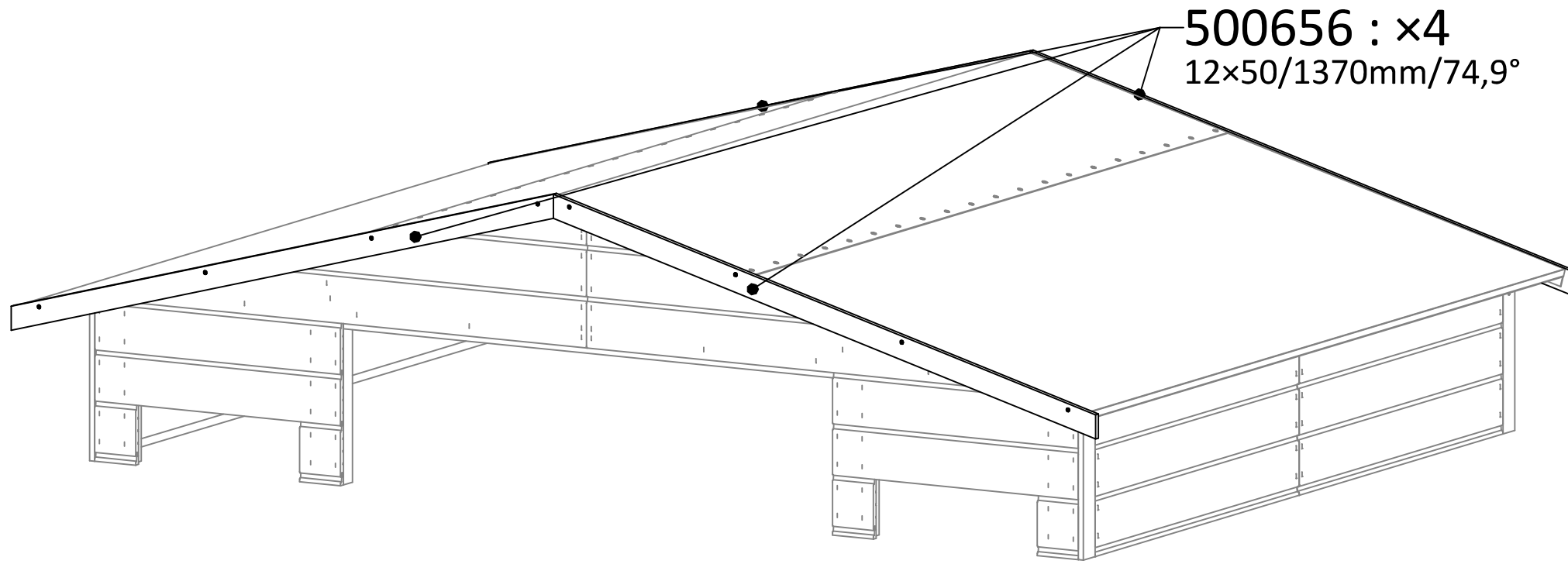

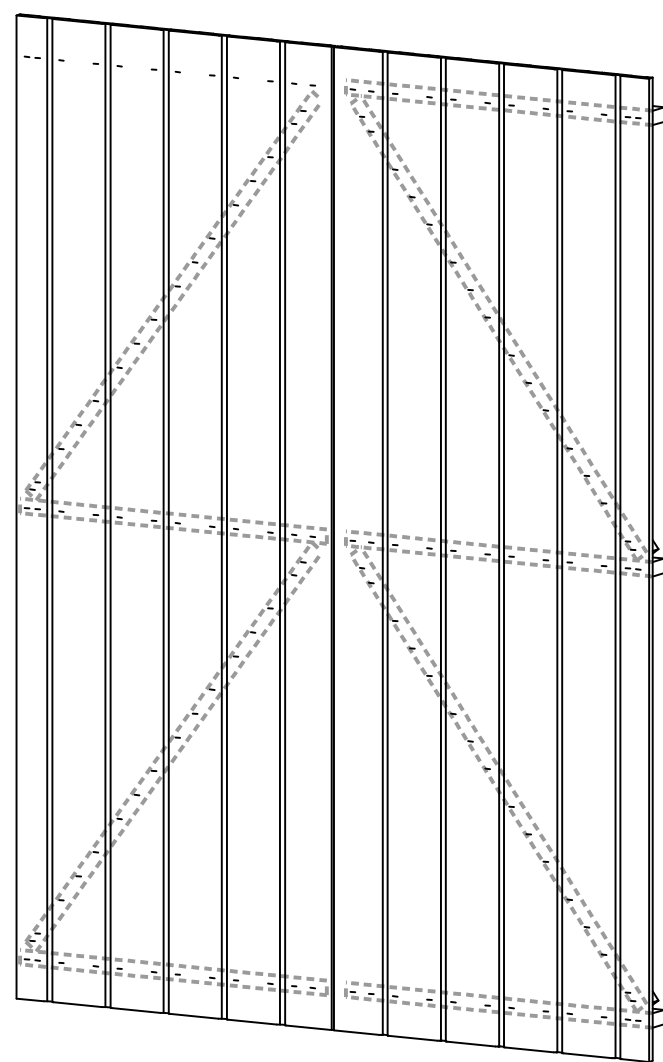

10

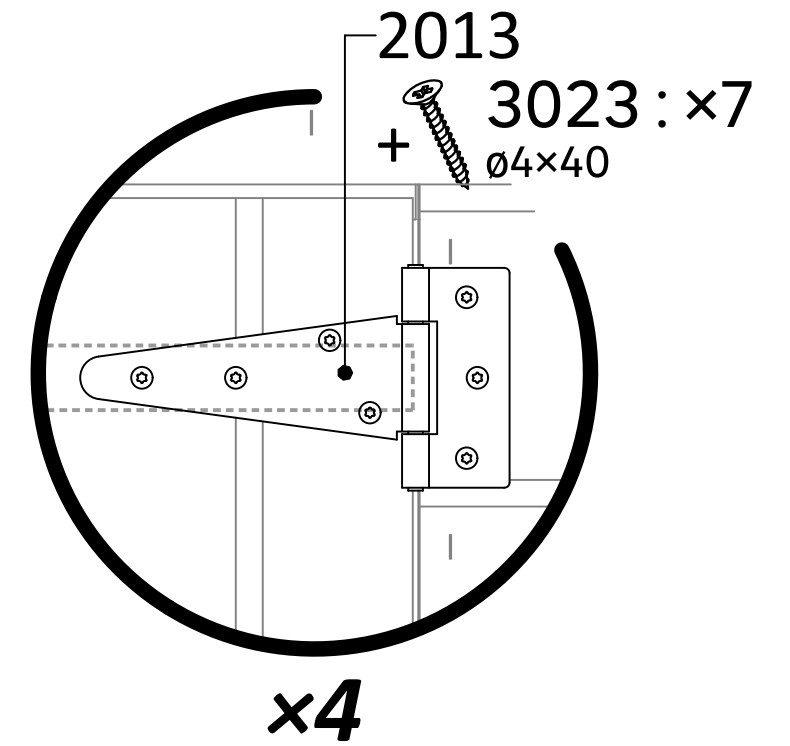
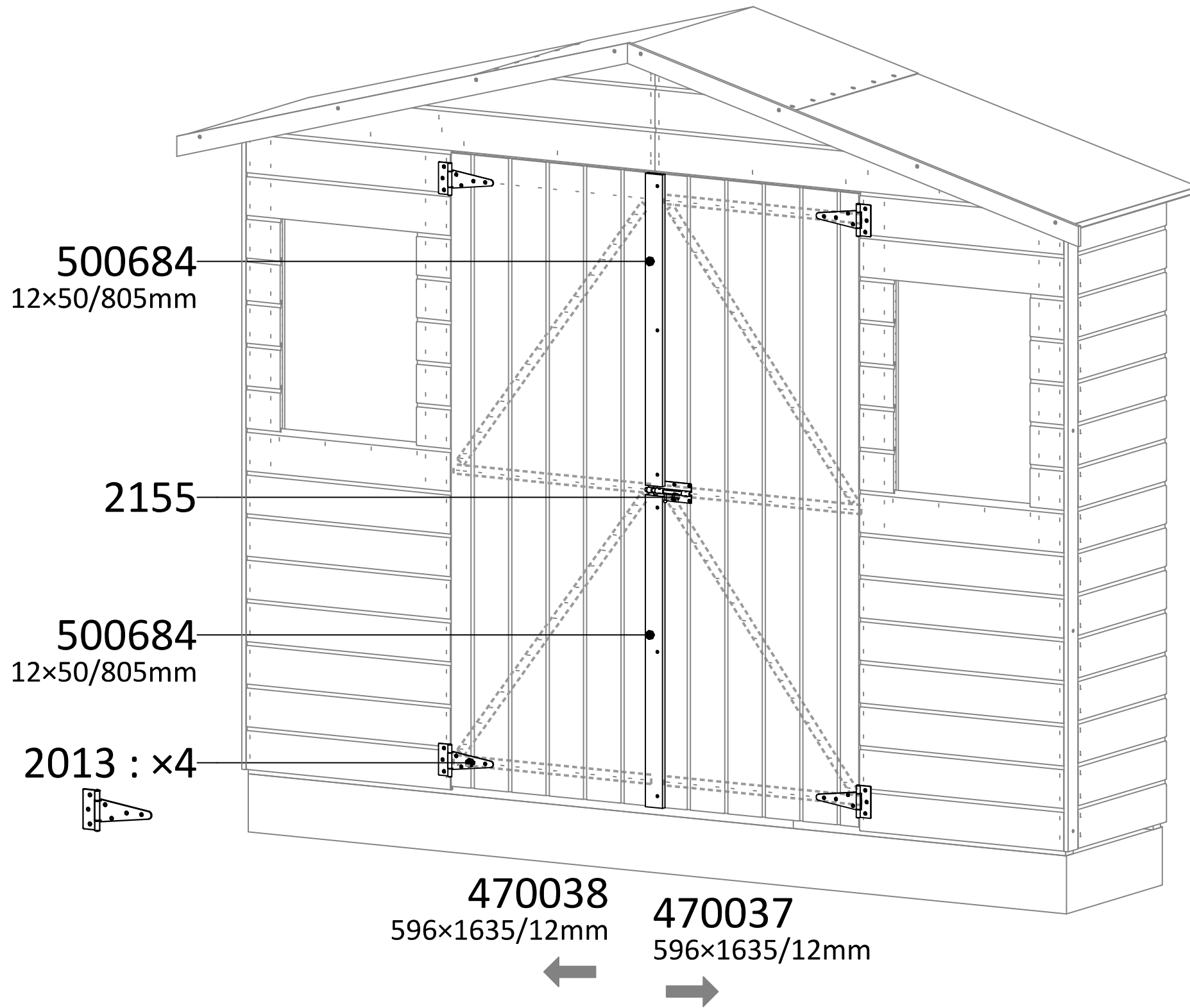

470038 470037  
596×1635/12mm 596×1635/12mm  
← →

# 11



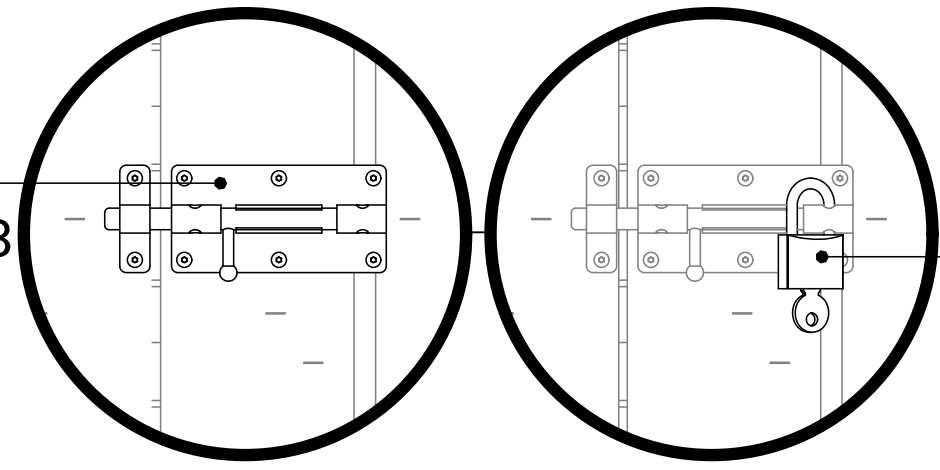

2155  
+  3009 : x8  
ø3,5x12

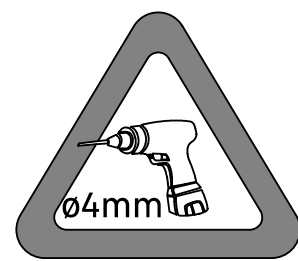

2181

500684  
12x50/805mm  
+  3012 : x3  
ø3,5x25



500684  
12x50/805mm  
+  3012 : x3  
ø3,5x25

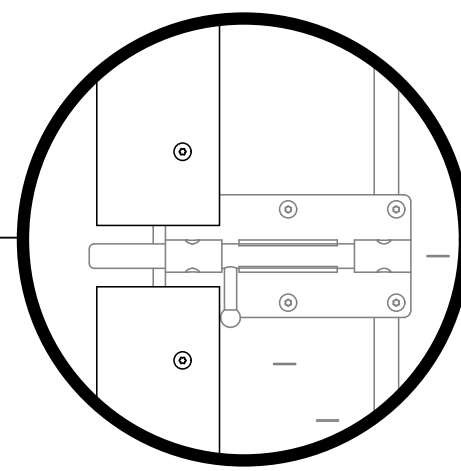
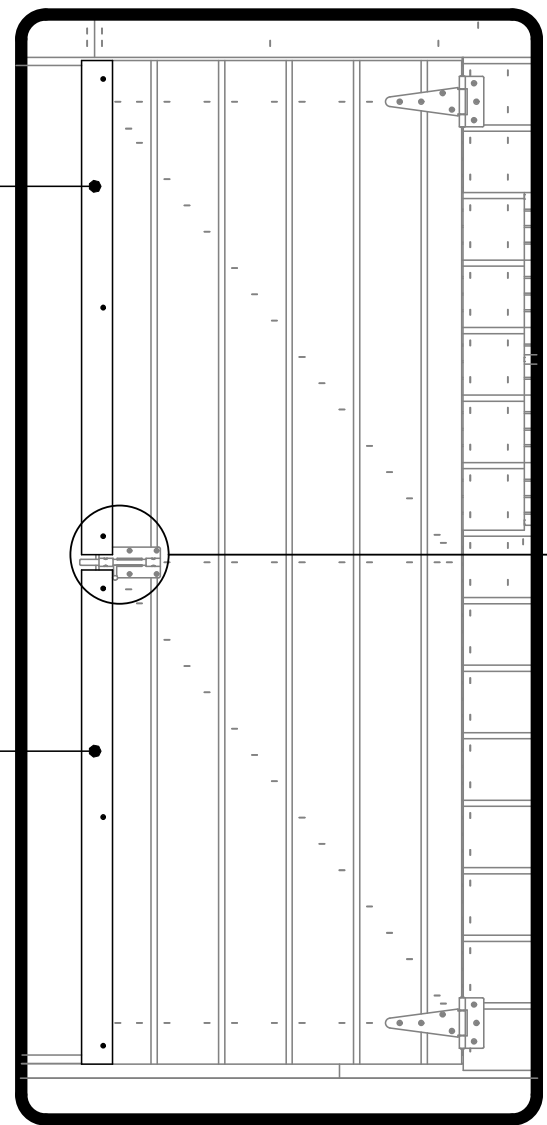

12

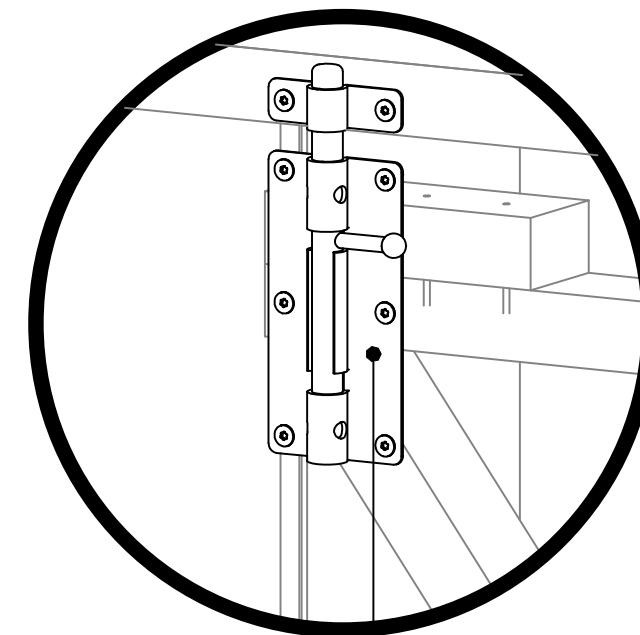
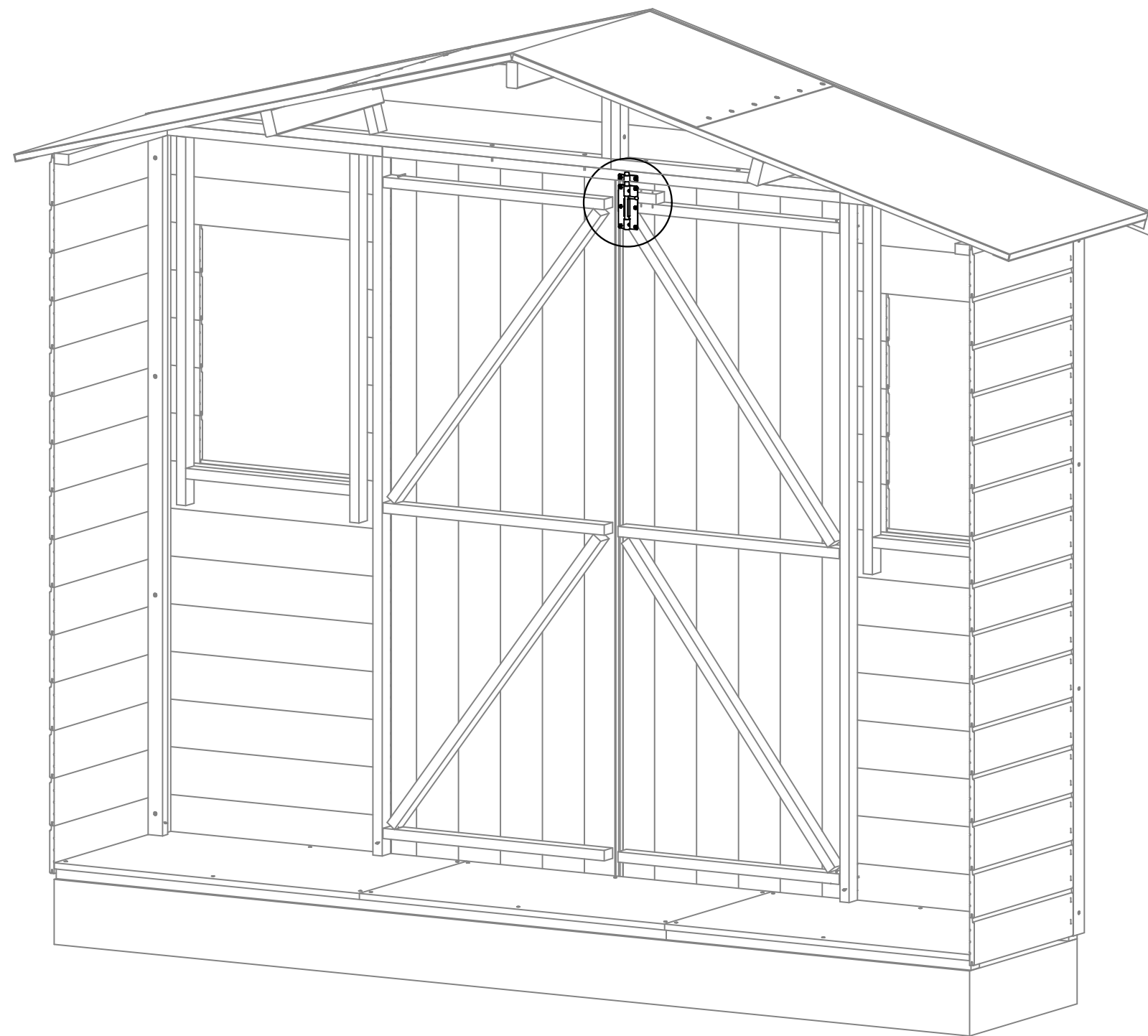

2155  
+  3009 : x8  
ø3,5x12

13

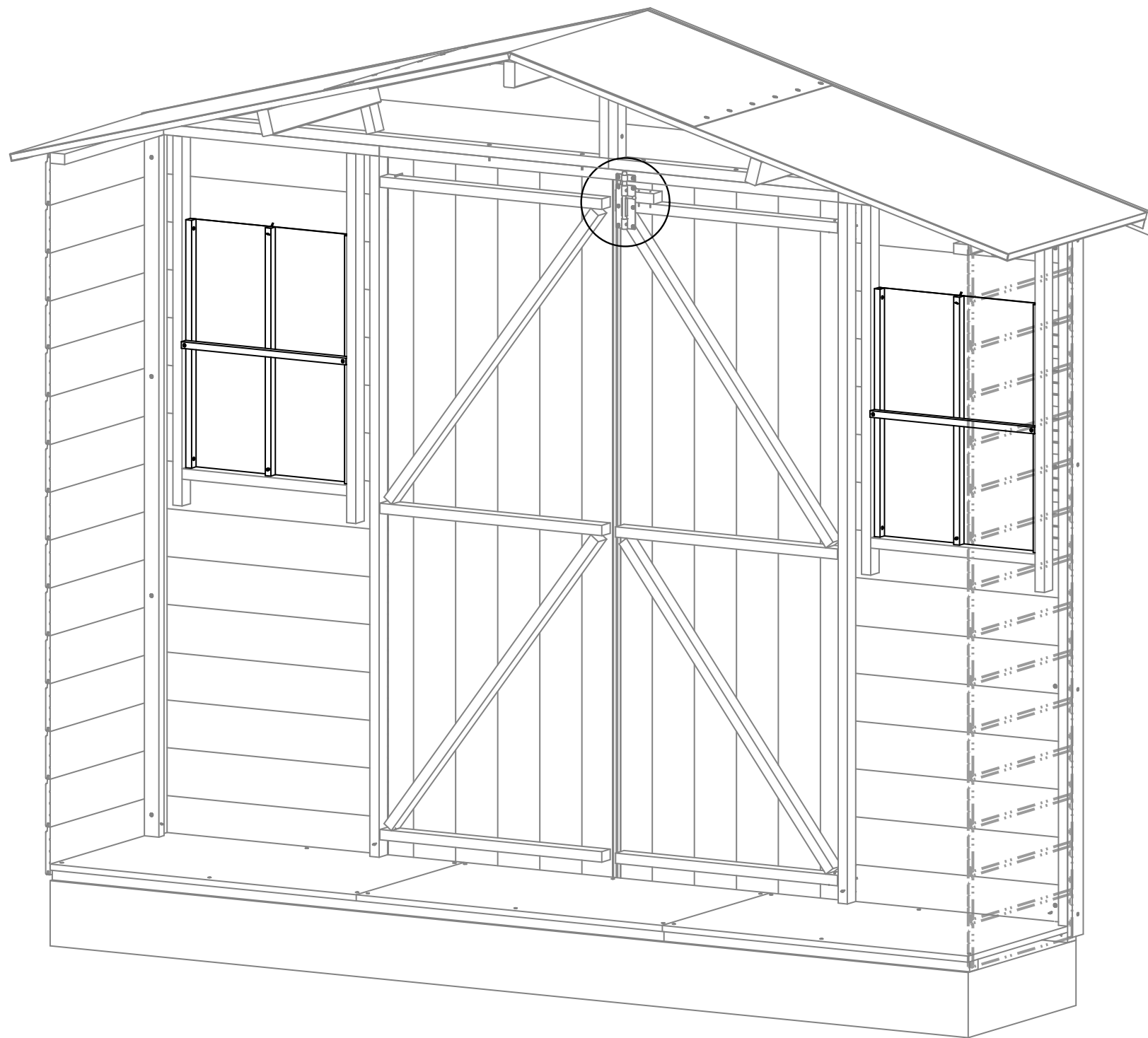



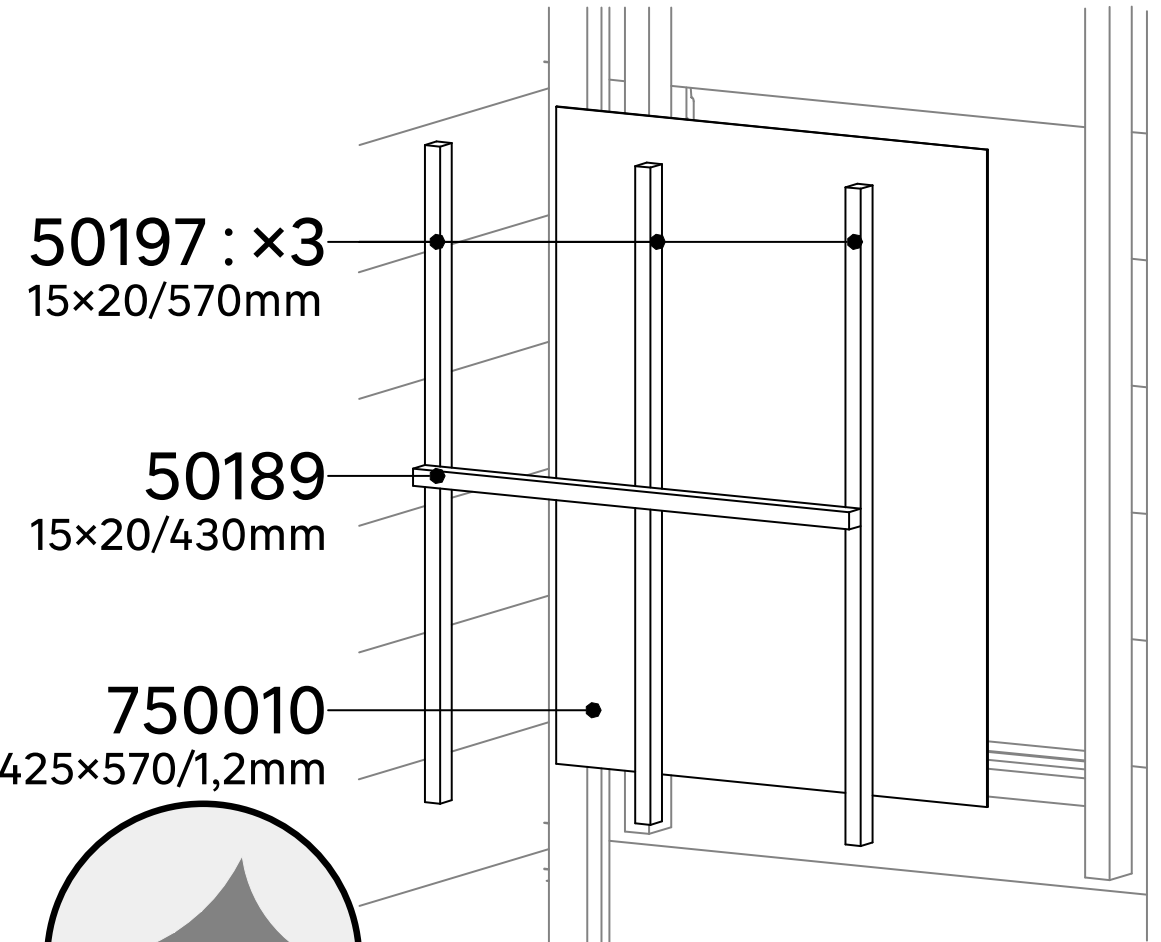

50197 : ×3  
15×20/570mm

50189  
15×20/430mm

750010  
425×570/1,2mm

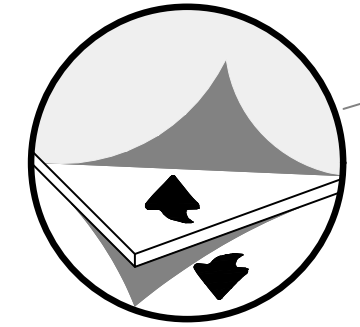

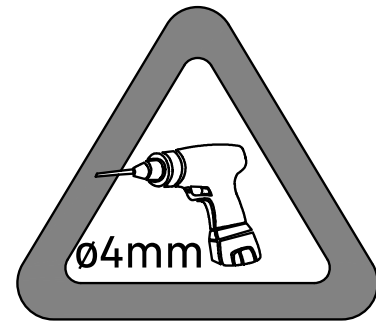

**x2**

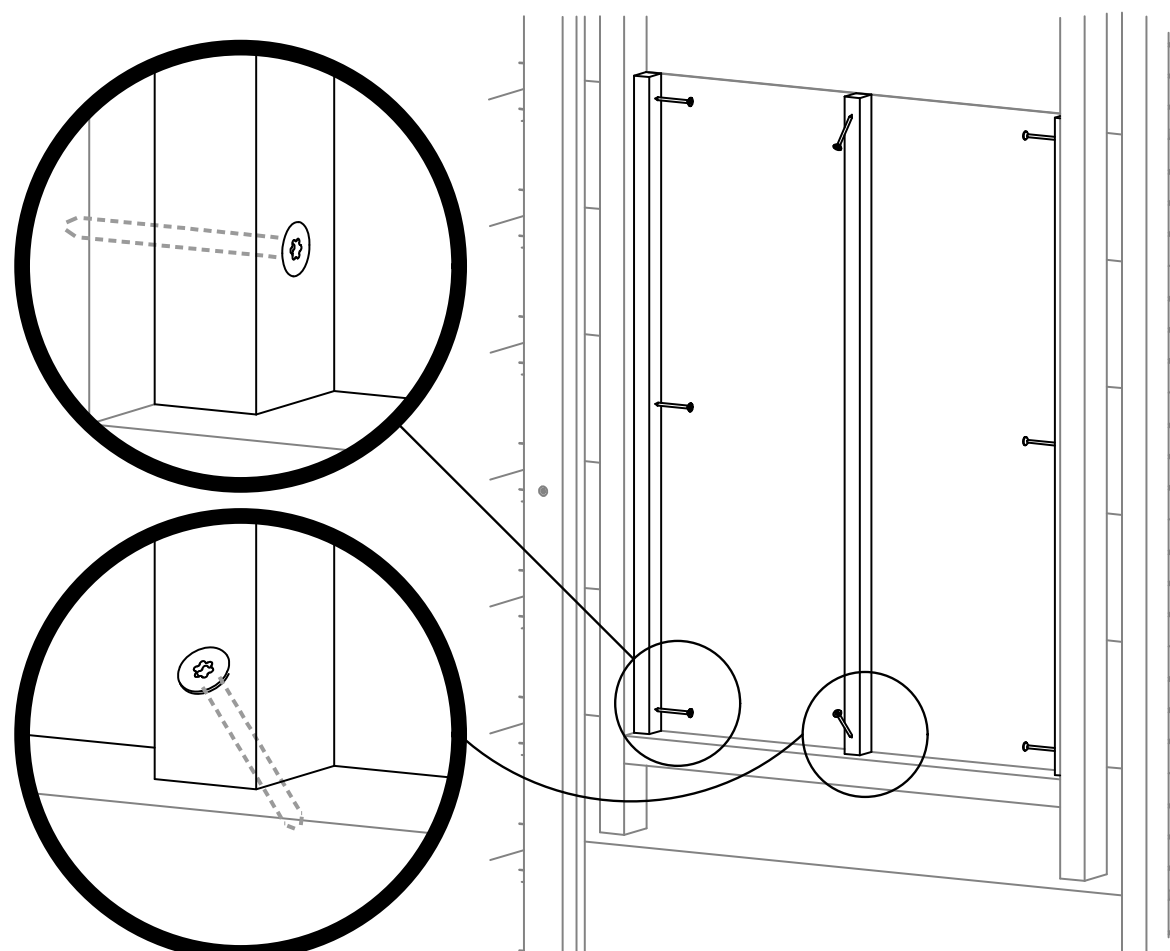

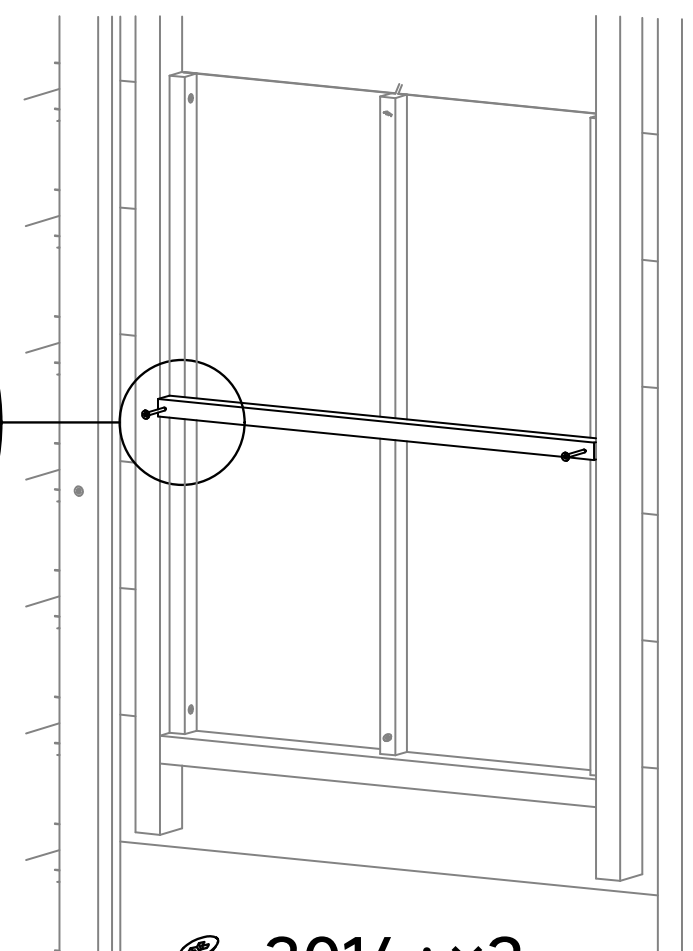
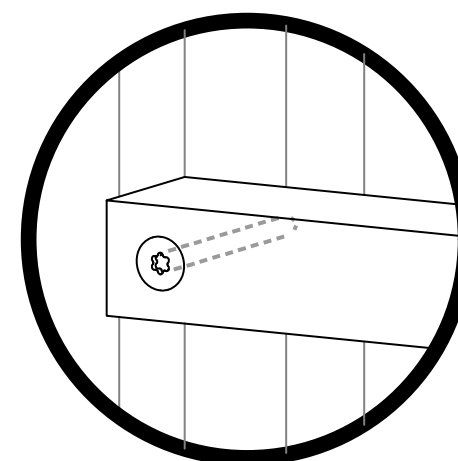

 **3014 : ×8**  
Ø3,5×35



 **3014 : ×2**  
Ø3,5×35



# Silicone / Mastic

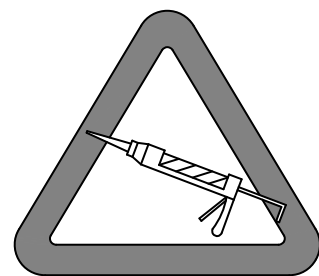

**FR** non incluse

**ES** non incluida

**PT** não incluído

**IT** non incluso

**EL** δεν περιλαμβάνεται

**PL** brak w zestawie

**UA** не входить у комплект

**RO** element neinclus

**EN** not included

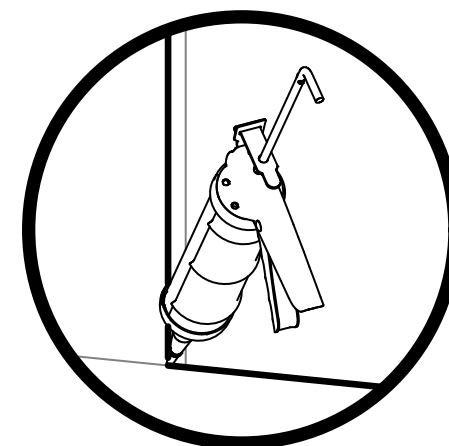
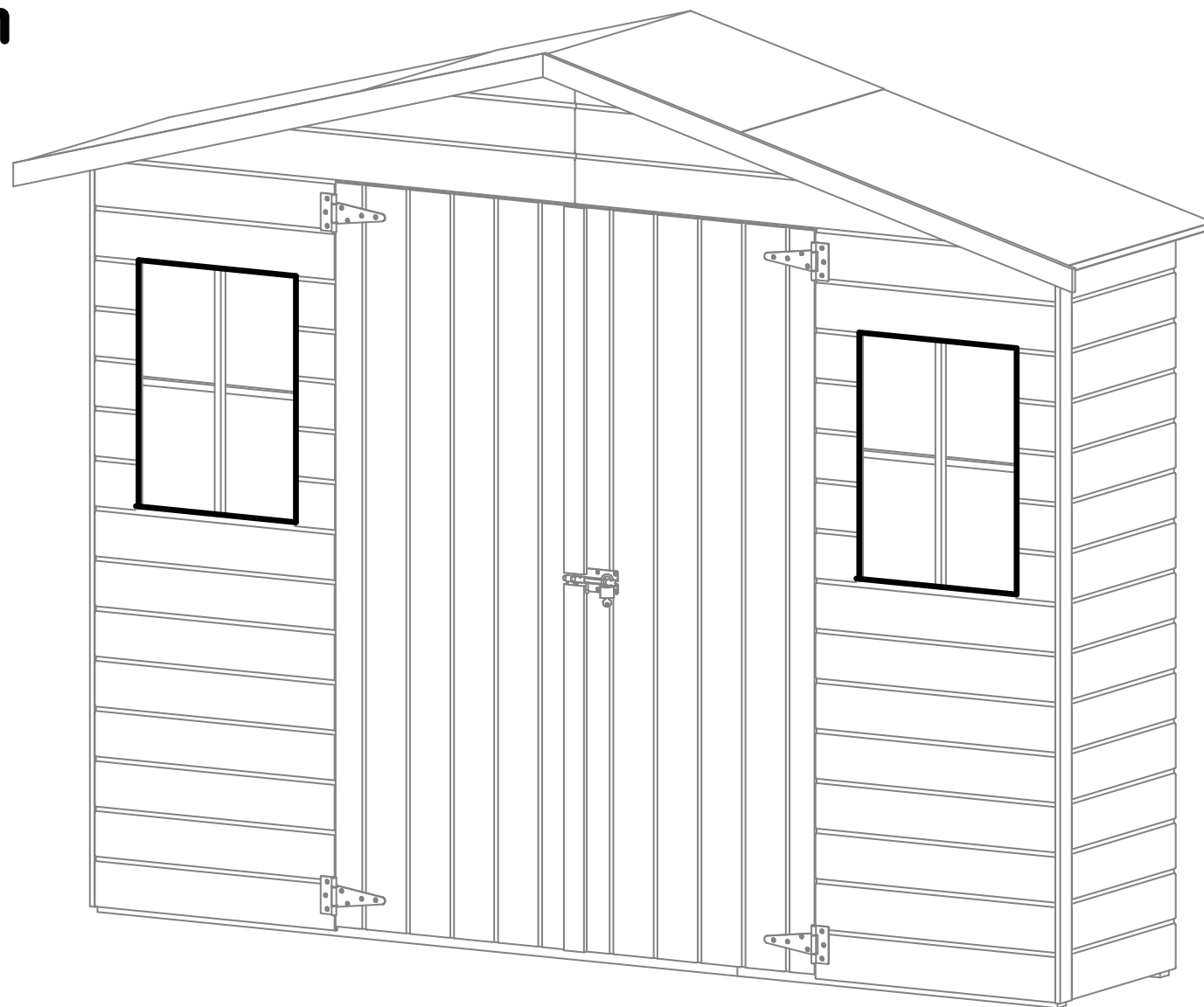
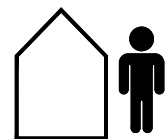

**FR** Ce produit est recyclable. S'il ne peut plus être utilisé, veuillez l'apporter dans un centre de recyclage de déchets.

**ES** Este producto es reciclable. Si ya no se puede usar, llévalo a un centro de reciclaje de residuos.

**PT** Este produto é reciclável. Se deixar de o utilizar, entregue-o num centro de reciclagem de resíduos.

**IT** Questo prodotto può essere riciclato. Se deve essere smaltito, portalo presso un centro di riciclaggio.

**EL** Αυτό το προϊόν είναι ανακυκλώσιμο. Εάν δεν μπορεί πλέον να χρησιμοποιηθεί, μεταφέρετε την σε κάποιο κέντρο ανακύκλωσης απορριμμάτων.

**PL** Ten produkt poddawany jest recyklingowi, kiedy przestaje być użyteczny należy dostarczyć go do punktu zbiórki odpadów.

**UA** Цей продукт може перероблятися. Якщо воно більше не є придатне для використання, здайте його в утилізаційний центр.

**RO** Acest produs este reciclabil. Dacă nu mai poate fi folosit, vă rugăm să îl aduceți într-un centru de reciclare a deșeurilor.

**EN** This product is recyclable. If it cannot be used anymore, please take it to waste recycling centre.



**\* Bois garantie 3 ans / 3 años de garantía maderá / Madeira garantia de 3 anos / Legno garanzia 3 anni / Ξύλο εγγύηση 3 ετών / Drewno gwarancja 3-letnia / Деревина гарантія 3 роки / Lemn garanție 3 ani / 3-year warranty wood**



**\*\* Feutre bitumeux, quincaillerie et accessoires garantie 1 an / 1 año de garantía fieltro asfáltico, ferretería y accesorios / Feltros asfáltico, ferragens e acessórios garantia de 1 ano / Fieltro bituminoso, ferramenta e accessori garanzia 1 anni / Ασφαλτόπανο, ειδηρικά και αξεσουάρ εγγύηση 1 έτος / Filc bitumiczny, sprzęt i akcesoria gwarancja 1 rok / Бітумна покрівля, фурнітура та аксесуари гарантія 1 рік / Fieltro bituminoso, feronerie și accesorii garanție 1 ani / Bituminous felt, hardware, and accessories 1-year warranty**