

EAN : 3276007889758
MATRIX ID : 2025R09P11-0003



FR Manuel d'Instructions

ES Manual de Instrucciones

PT Manual de Instruções

IT Manuale di Istruzioni

EL Εγχειρίδιο Οδηγιών

PL Instrukcja Obsługi

UA Інструкція з експлуатації

RO Manual de Instrucțiuni

EN Instructions Manual

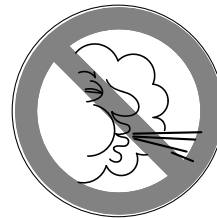
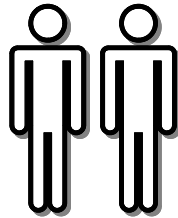
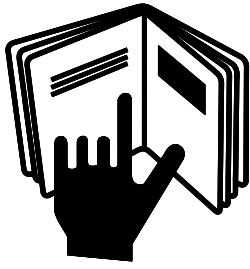

max. 50kg/m²

max. 50km/h

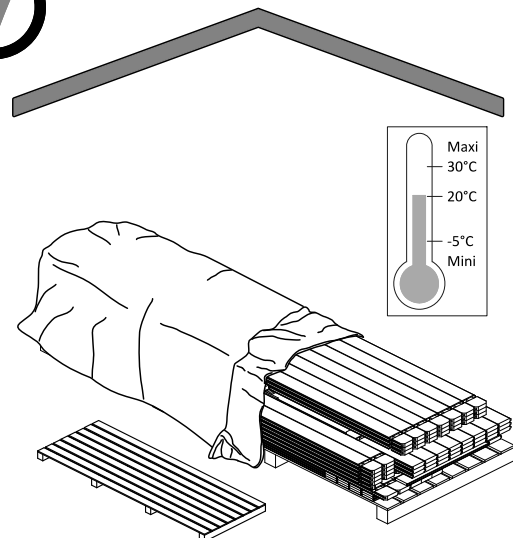
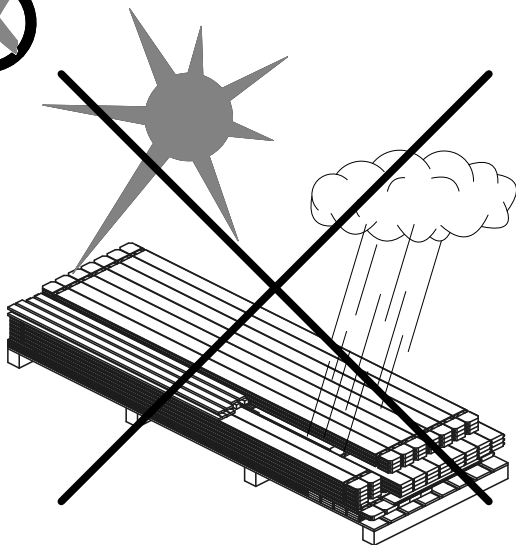
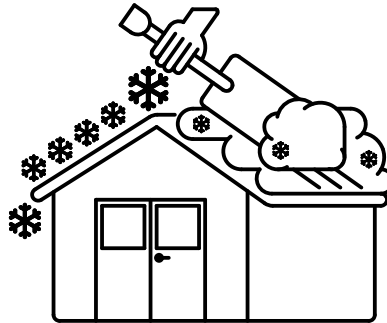

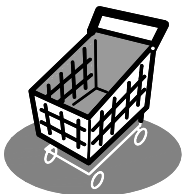
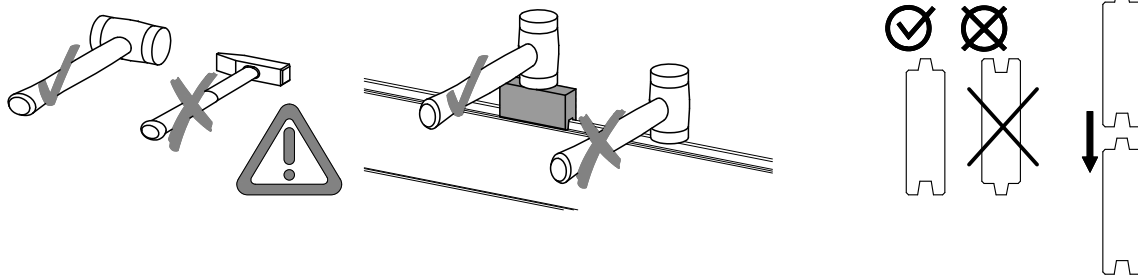
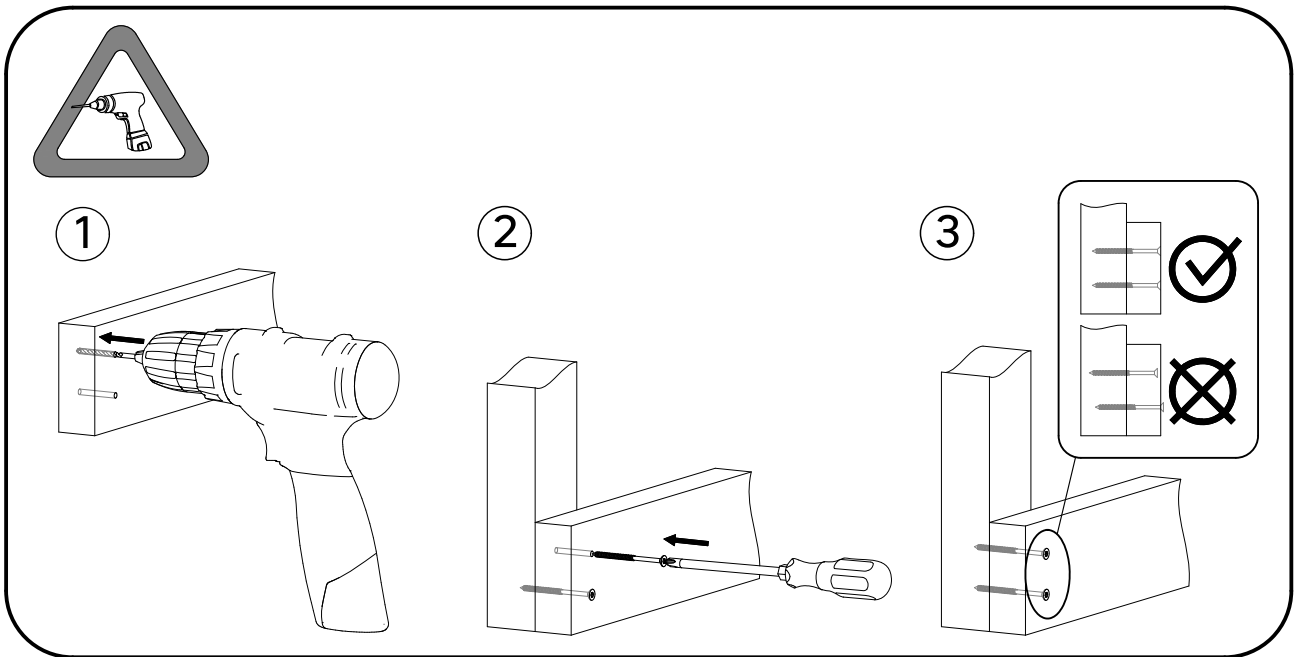
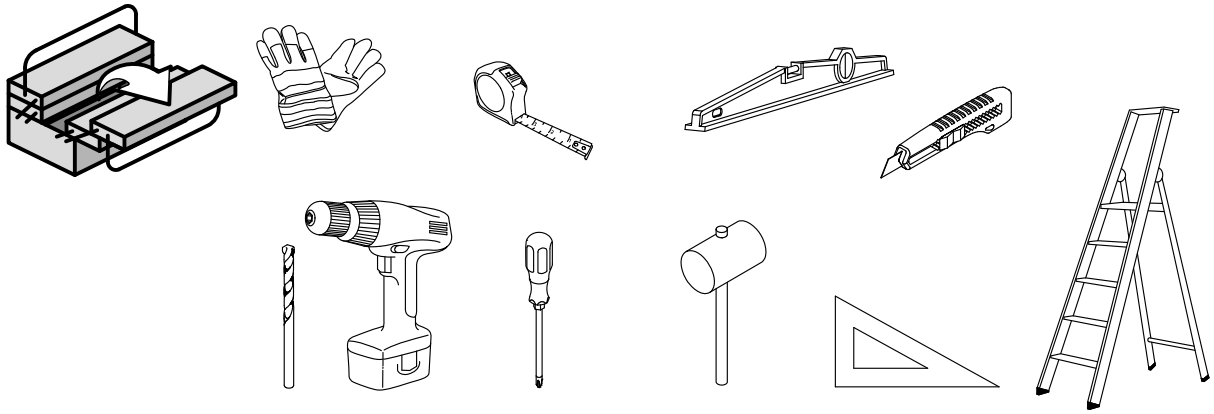

Silicone Mastic



FR Colle pour le feutre bitumeux.

IT Colla per tela buttumata.

UA Адезив pentru membrană bituminoasă.

ES Pegamento para tela asfáltica.

EL Κόλλα για ασφαλτόπανο.

RO Клей для бітумінізованого войлоку.

PT Cola para tecido asfáltico.

PL Klej do papy bitumicznej.

EN Glue for the roof.

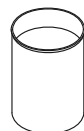

FR Protection pour le bois en extérieur : 2 couches avant montage.

IT Protezione per il legno in esterno : due mani prima del montaggio.

UA Προστασία για ξύλινες επιφάνειες εξωτερικού χώρου: 2 στρώσεις πριν από τη συναρμολόγηση.

ES Protección para la madera de exteriores: 2 manos antes del montaje.

EL Προστασία για ξύλινες επιφάνειες εξωτερικού χώρου: 2 στρώσεις πριν από τη συναρμολόγηση.

RO Protecție pentru lemn la exterior: 2 straturi înainte de montaj.

PT Proteção para madeira exterior: 2 demãos antes da montagem.

PL Ochrona drewna na zewnątrz: 2 warstwy przed montażem.

EN Wood preserver for the outside : 2 layers before assembly.



Denali

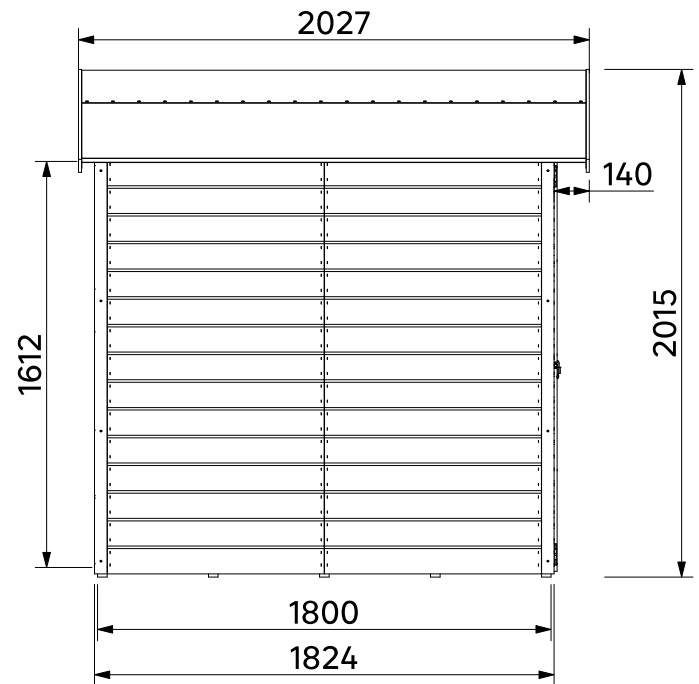
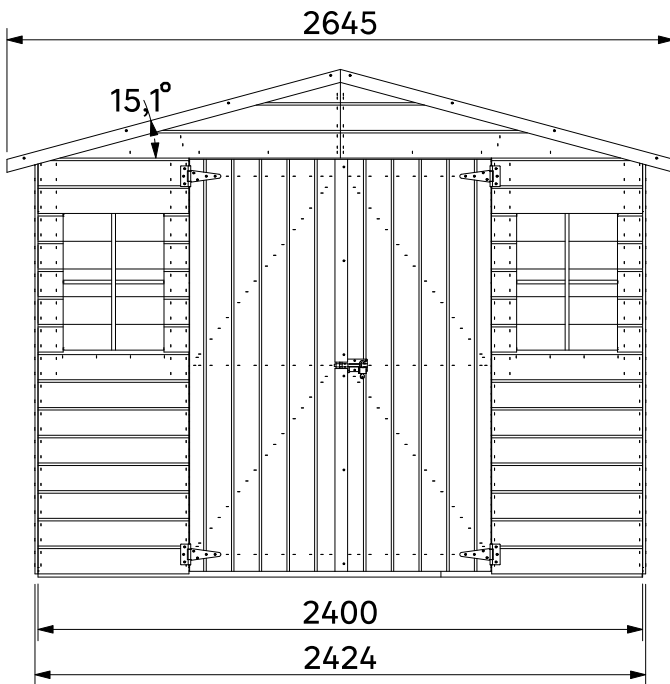

<p>FR Sol nivelé requis. Pose sur dalle béton parfaitement plate et de niveau (non incluse).</p>	<p>ES Es necesario un suelo nivelado. Colocar sobre losa de hormigón perfectamente plana y nivelada (non incluida).</p>	<p>PT É necessário um solo nivelado. Montagem sobre laje de betão perfectamente plana e nivelada (não incluído).</p>
<p>IT È richiesto un fondo livellato. Posare su pavimenti in cemento perfettamente in piano e livellato (non incluso).</p>	<p>EL Απαιτείται επίπεδο έδαφος. Πρέπει να τοποθετείται πάνω σε απόλυτα επίπεδη και οριζόντια πλάκα σκυροδέματος (δεν περιλαμβάνεται).</p>	<p>PL Wymagane wyrównanie i wypoziomowanie podłoża. Montaż na idealnie płaskiej i wypoziomowanej płycie betonowej (brak w zestawie).</p>
<p>UA Necesár teren plat. Montare pe dală de beton perfect plată și la nivel (nu este inclusă).</p>	<p>RO Необхідно забезпечити рівну ділянку землі. Укладання на ідеально рівну і вирівняну бетонну плиту (не входить у комплект).</p>	<p>EN Level ground required. Laying on a perfectly flat and level concrete slab (not included).</p>

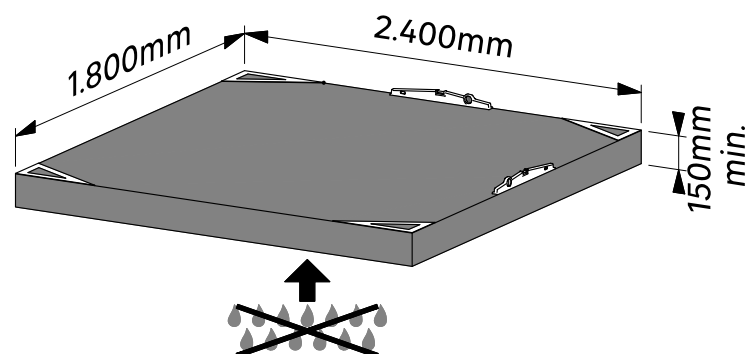

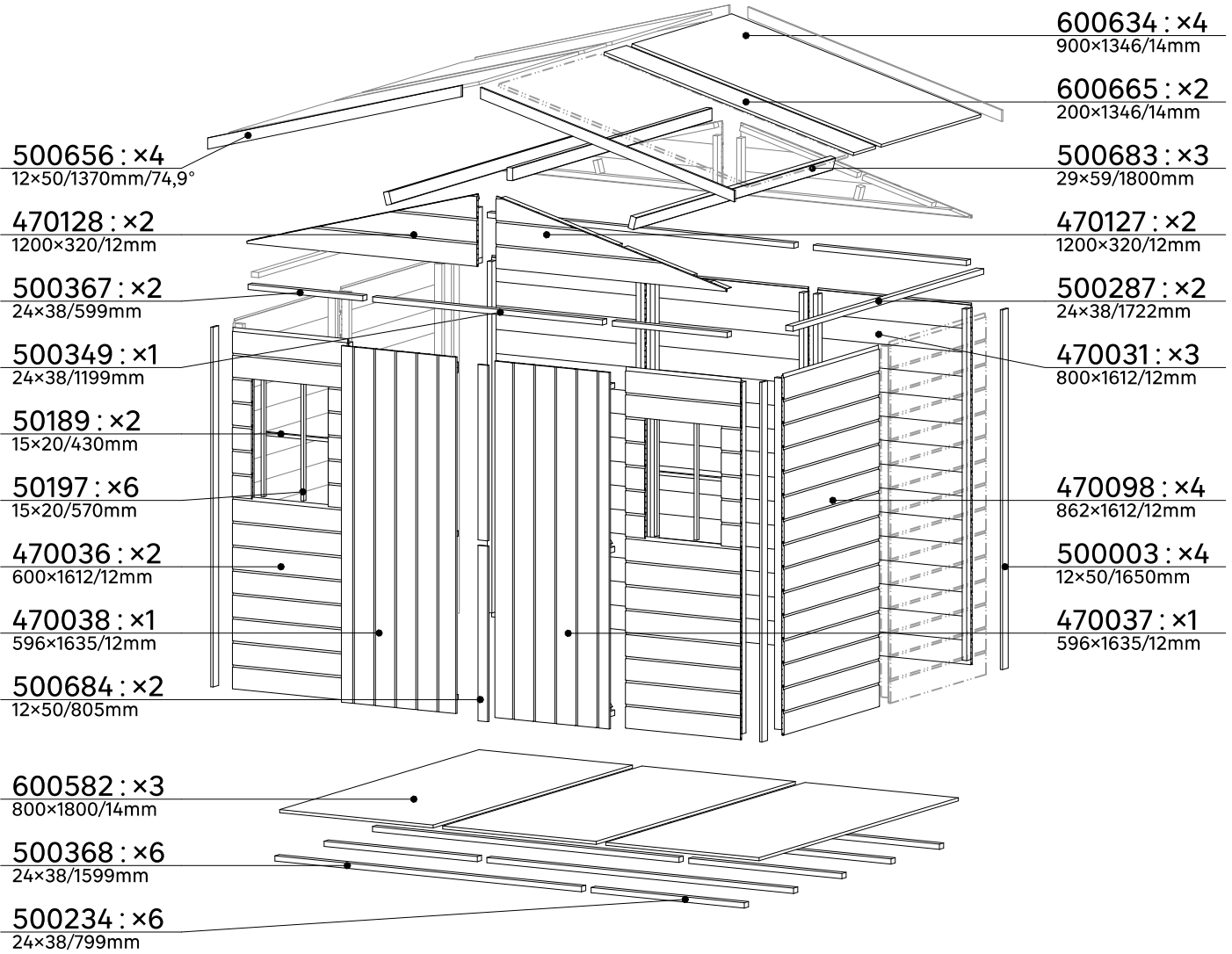

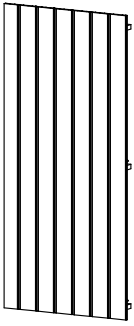

470037 → : 1
596×1635/12mm
470038 ← : 1
596×1635/12mm

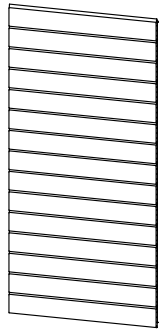

470031 : 3
800 × 1612 / 12mm
470098 : 4
862 × 1612 / 12mm

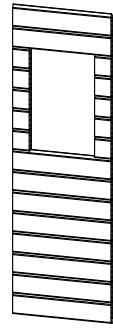

470036 : 2
600 × 1612 / 12mm

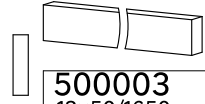

500003 : 4
12×50/1650mm
500684 : 2
12×50/805mm
50189 : 2
15×20/430mm
50197 : 6
15×20/570mm
500349 : 1
24×38/1199mm
500368 : 6
24×38/1599mm
500287 : 2
24×38/1722mm
500367 : 2
24×38/599mm
500234 : 6
24×38/799mm
500683 : 3
29×59/1800mm

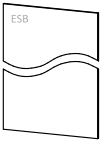

600665 : 2
200 × 1346 / 14mm
600582 : 3
800 × 1800 / 14mm
600634 : 4
900 × 1346 / 14mm



470128 : 2
1200 × 320 / 12mm

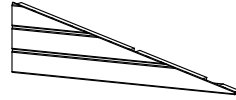

470127 : 2
1200 × 320 / 12mm

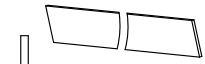

500656 : 4
12×50/1370mm/74,9°

Kit 700394			
	3009	∅3,5×12mm	16
	3012	∅3,5×25mm	22
	3014	∅3,5×35mm	65
	3023	∅4×40mm	128
	3025	∅4×50mm	16
	3027	∅4×60mm	60
Kit 700043			
	3810	∅2×15mm	90
Plexy			
	750010	425×570/1,2mm	2

Kit 700275					
	2013	4		2155	2
	2181	1			
	2915	∅4mm		1	
	1,5mm				
800003		1,00×6,60m		1	

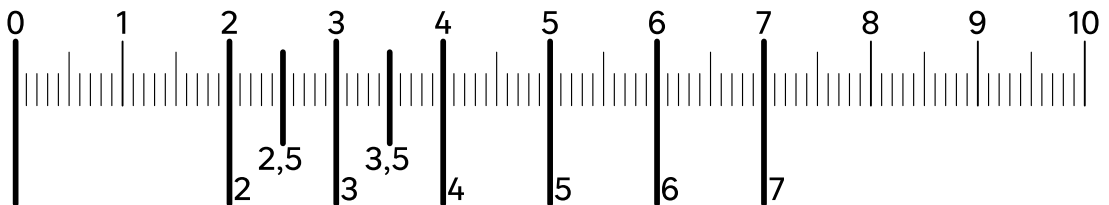



FR Technique pour assembler les panneaux, en les vissant entre-eux.	ES Técnica para ensamblar los paneles atornillándolos entre sí.	PT Técnica para a montagem de painéis aparafusando uns aos outros.
IT Tecnica per assemblare i pannelli, avvitandoli tra loro.	EL Τεχνική συναρμολόγησης πάνελ βιδώνοντάς τα μεταξύ τους.	PL Technika montażu paneli poprzez skręcanie ich ze sobą
UA Техніка монтажу панелей шляхом скріплення їх між собою гвинтами.	RO Tehnică pentru asamblarea panourilor, prin înșurubare între ele.	EN Technique for assembling panels by screwing them together.

1

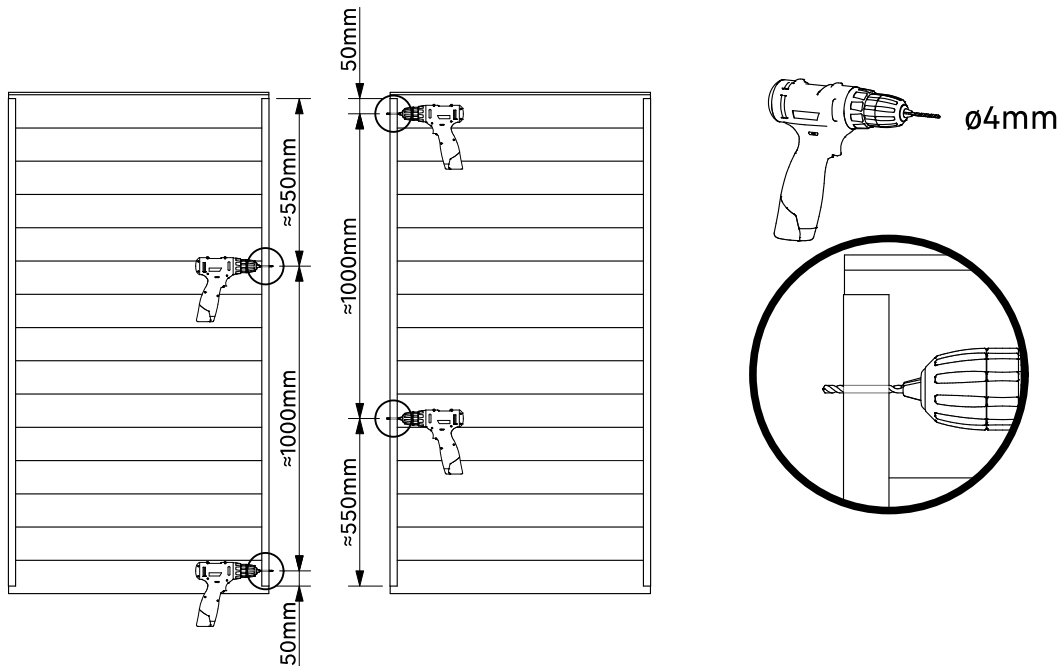

2

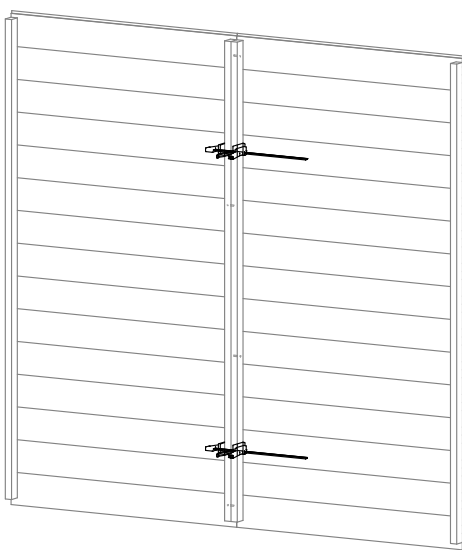

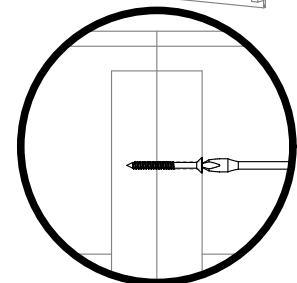
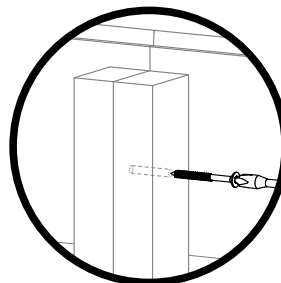
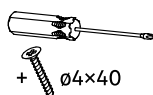
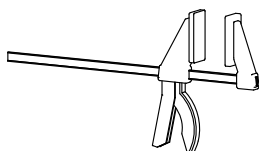

3



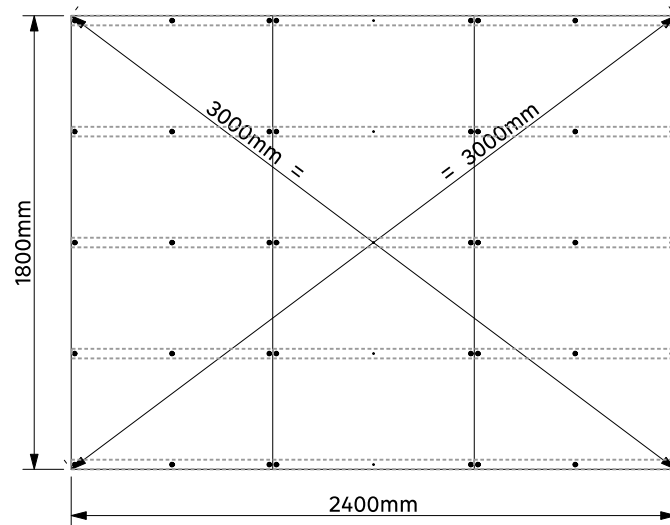
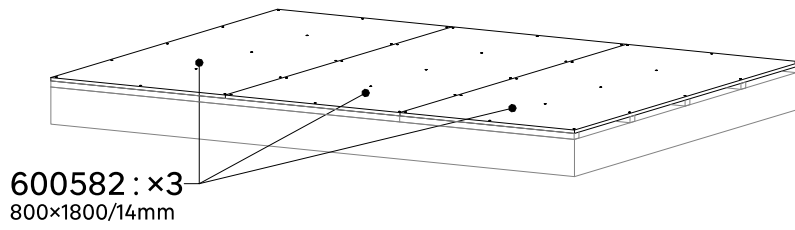
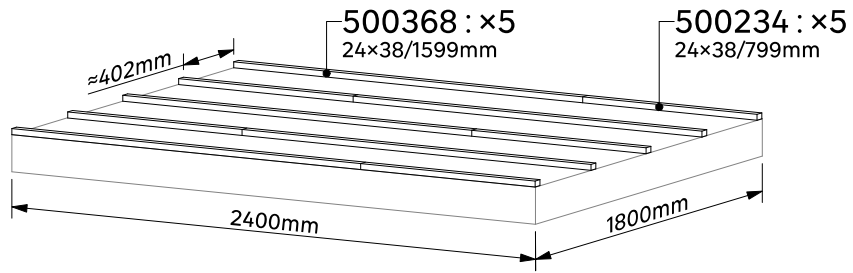

1



 3014 : x45
Ø3,5x35



2



2.1

A=

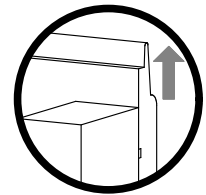
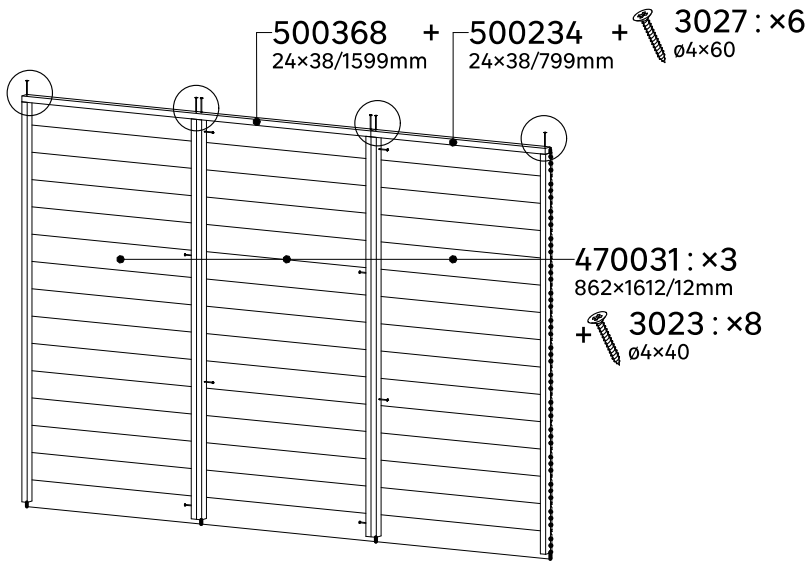

1

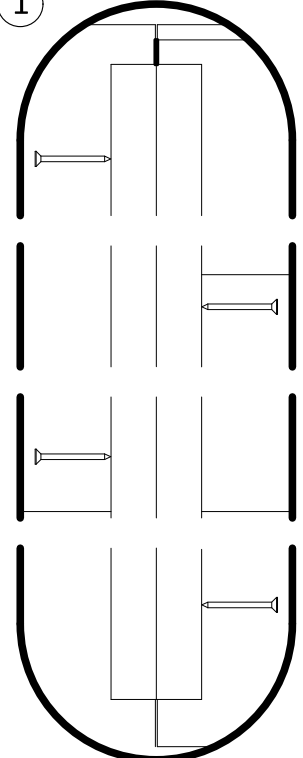

2.2

B=

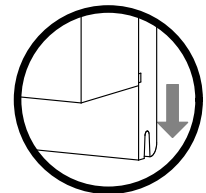
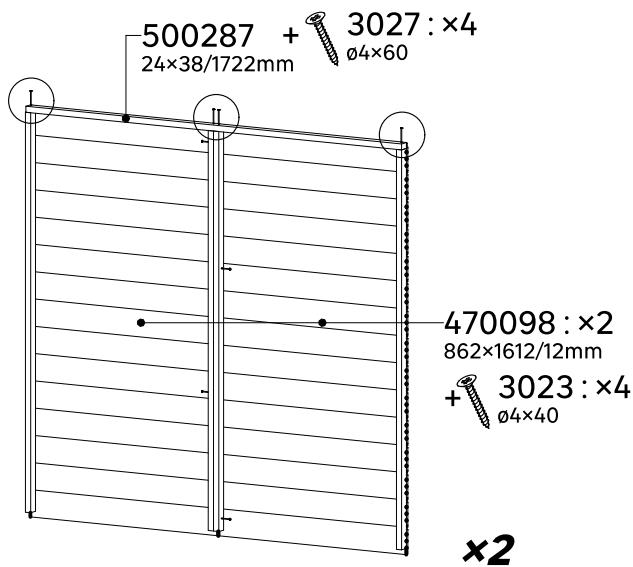

2

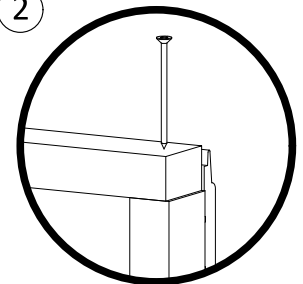

2.3

C=

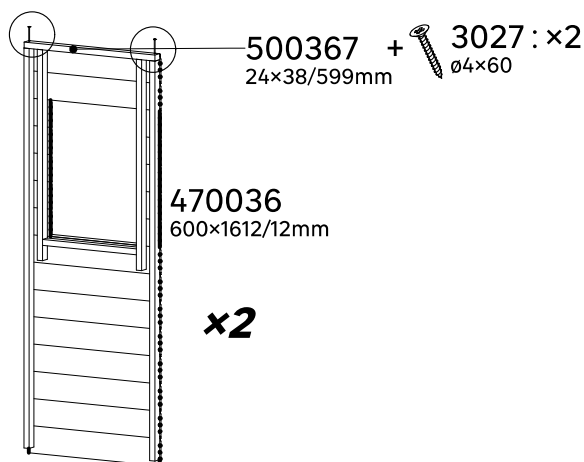



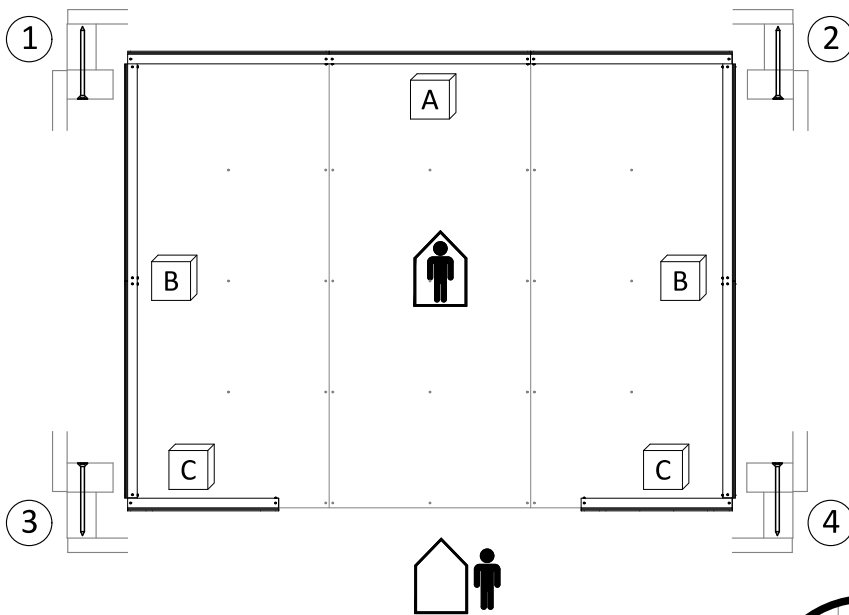
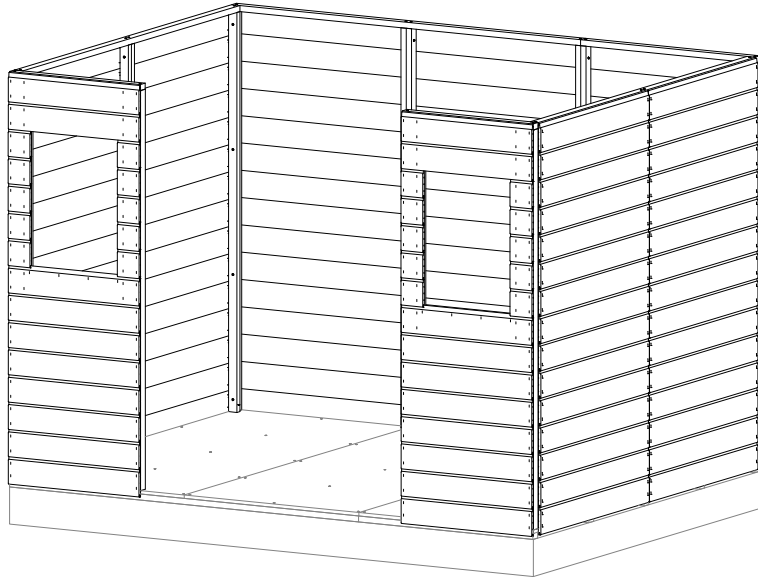

3

3.1

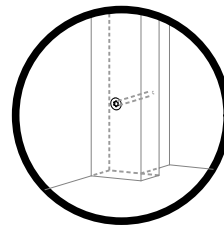
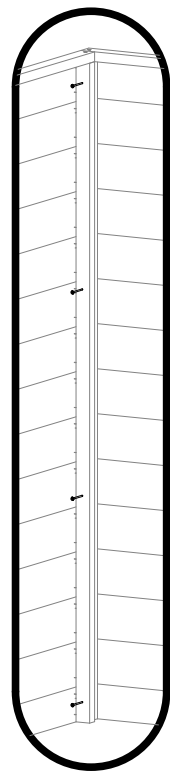

① ②
③ ④
= x4



 3025 : x4
ø4x50



3.2

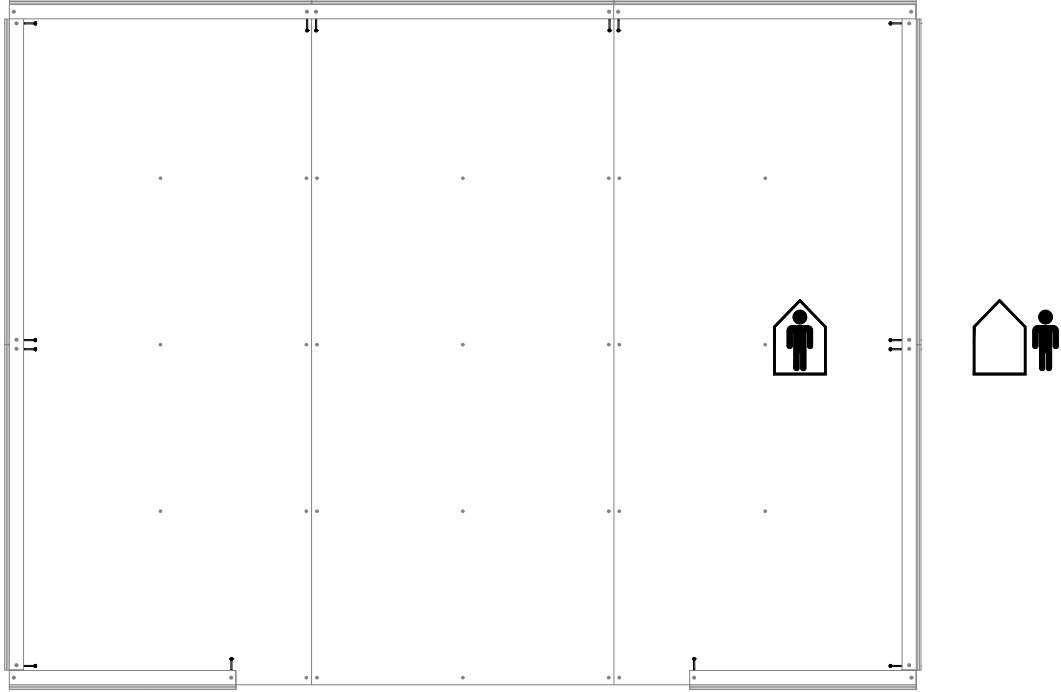

3027 : x14
Ø4x60

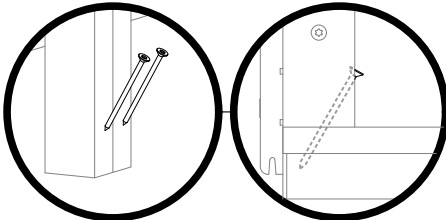
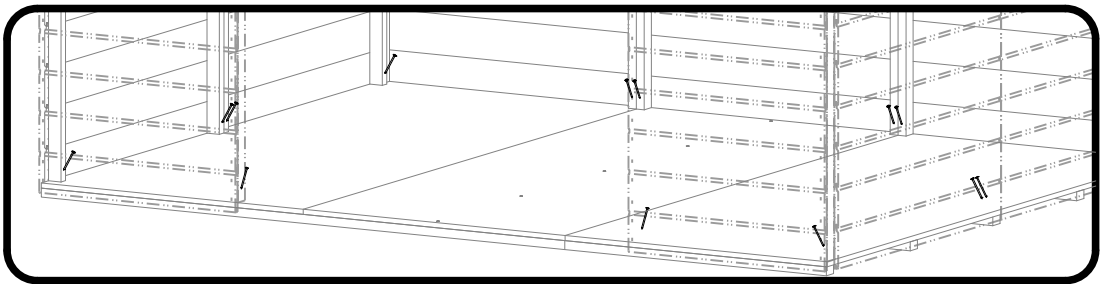



4

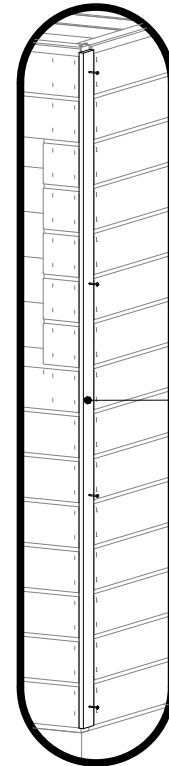
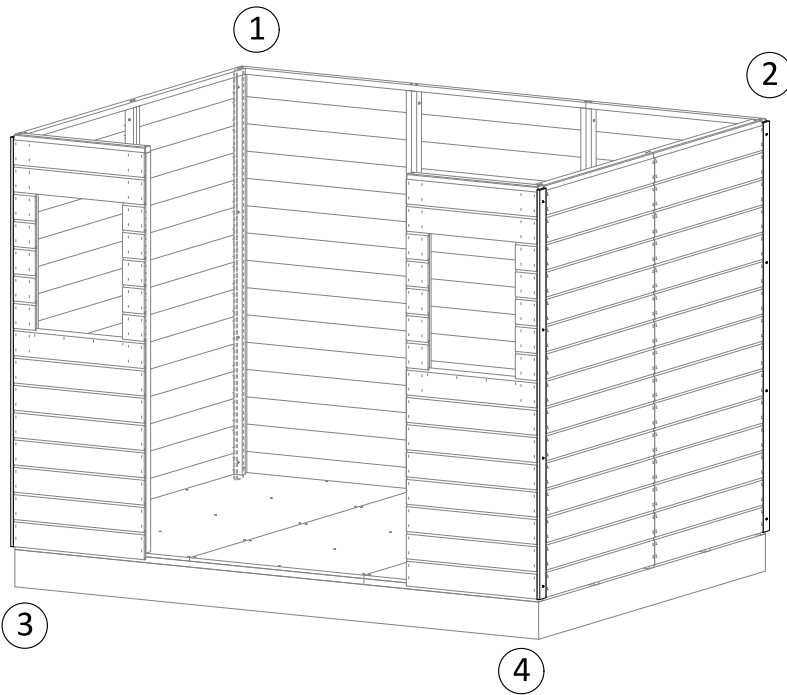

- ①
- ②
- ③
- ④

500003
12×50/1650mm
+ 3012 : ×4
Ø3,5×25
×4

5

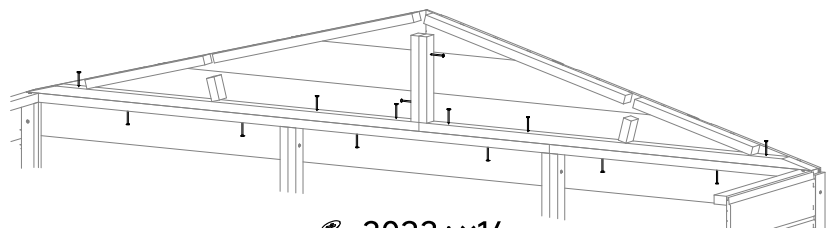
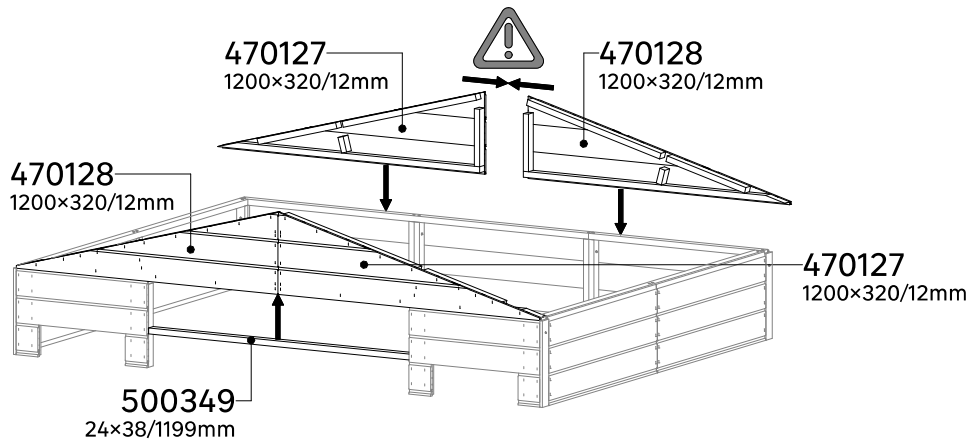

3023 : ×14
Ø4×40

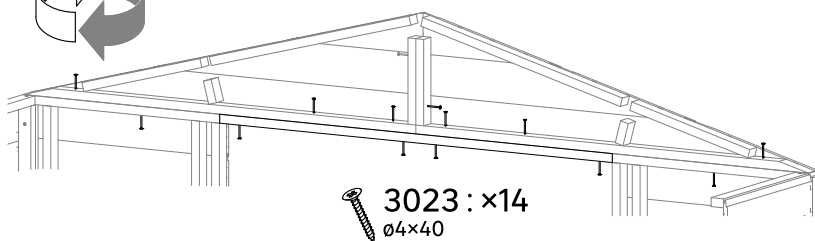

3023 : ×14
Ø4×40



6

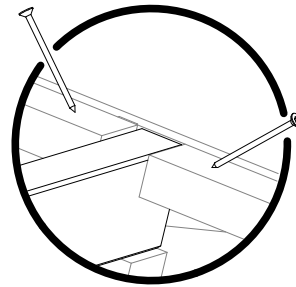
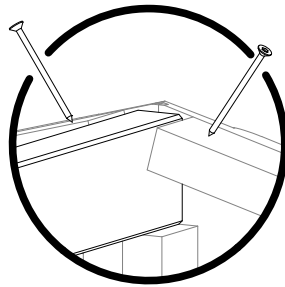
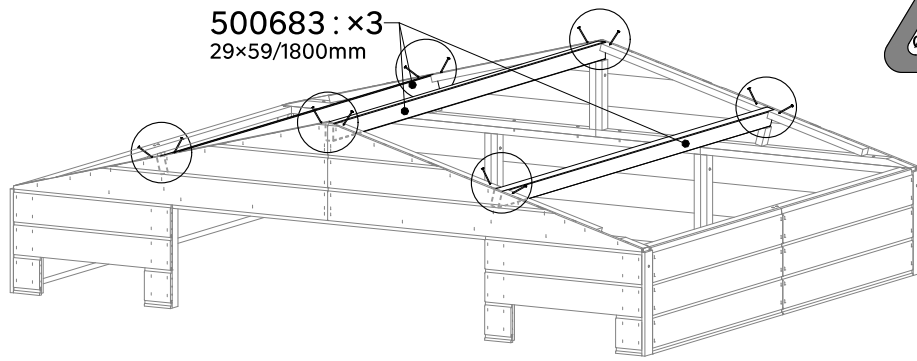

3027 : x2
ø4x60

x6

7

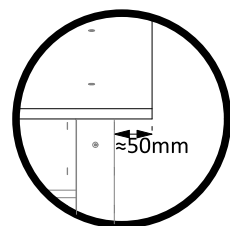
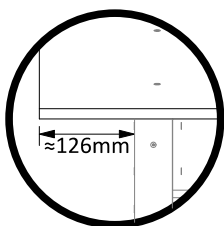
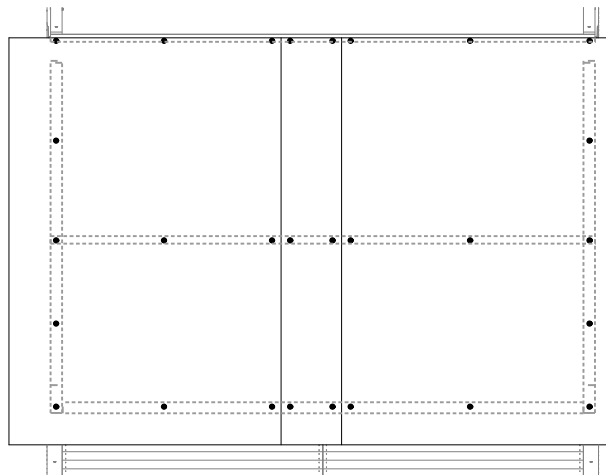
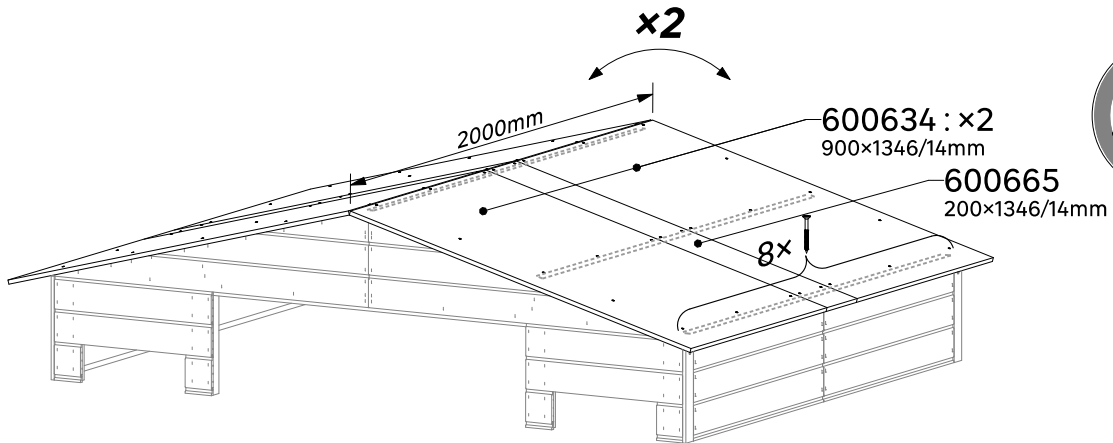



8

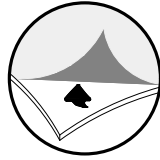
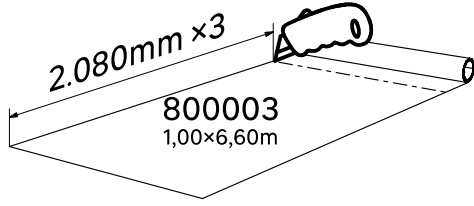

3810 : x90
15mm

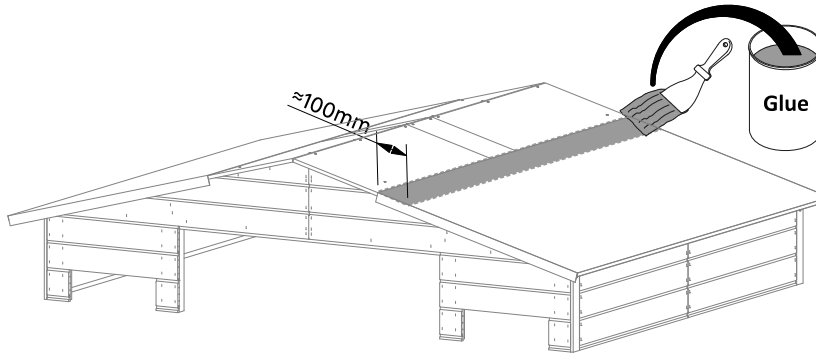
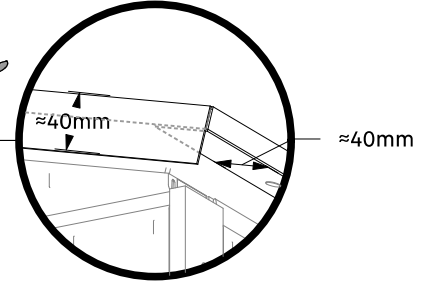
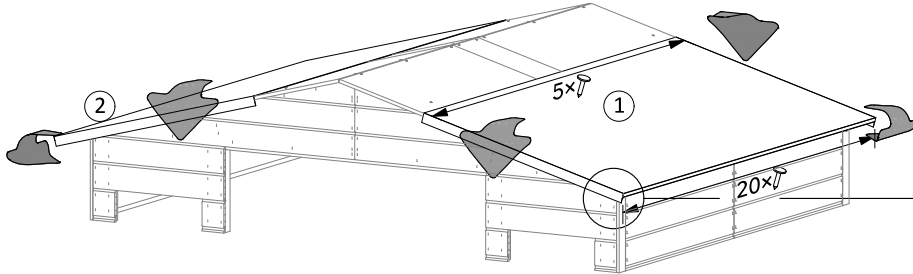

FR	non incluse	ES	non incluida	PT	não incluído
IT	non incluso	EL	δεν περιλαμβάνεται	PL	brak w zestawie
UA	не входить у комплект	RO	element neinclus	EN	not included

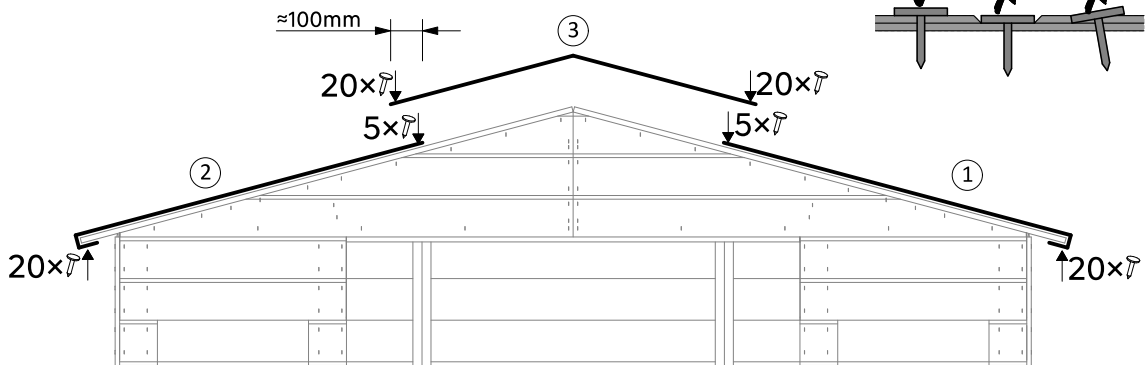
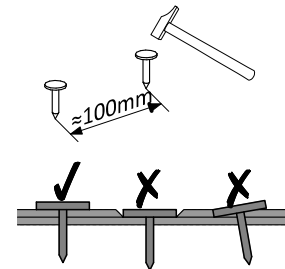
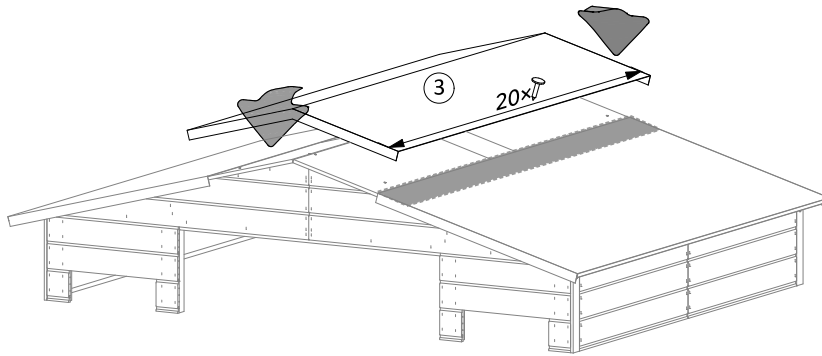



9

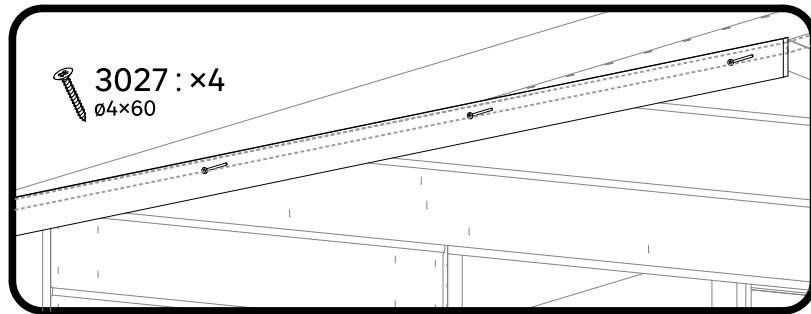
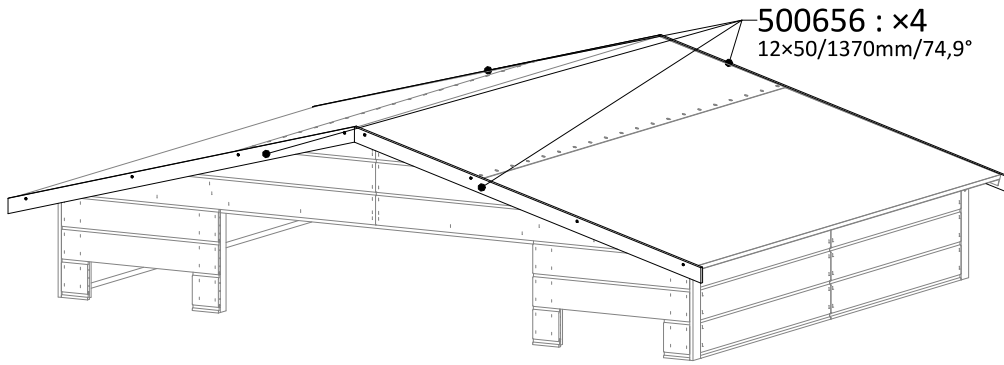

x4

10

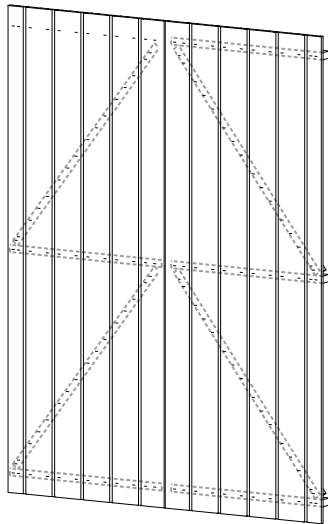

470038 470037
596x1635/12mm 596x1635/12mm

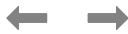



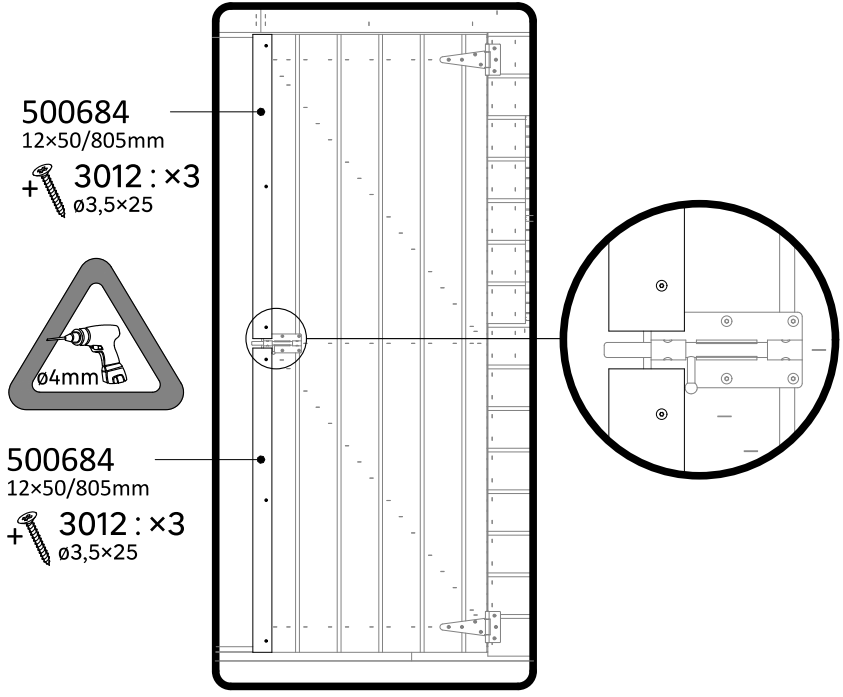
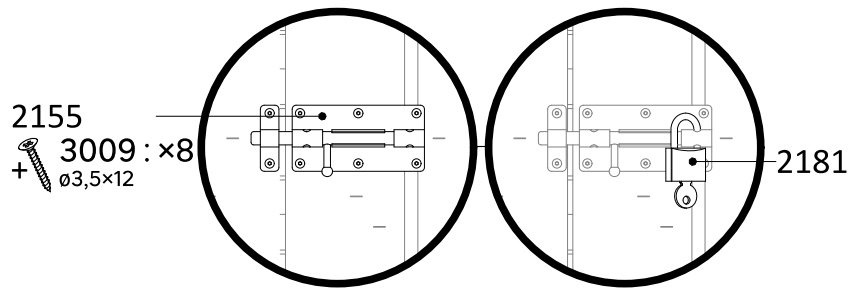
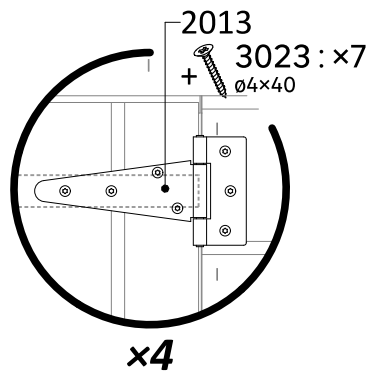
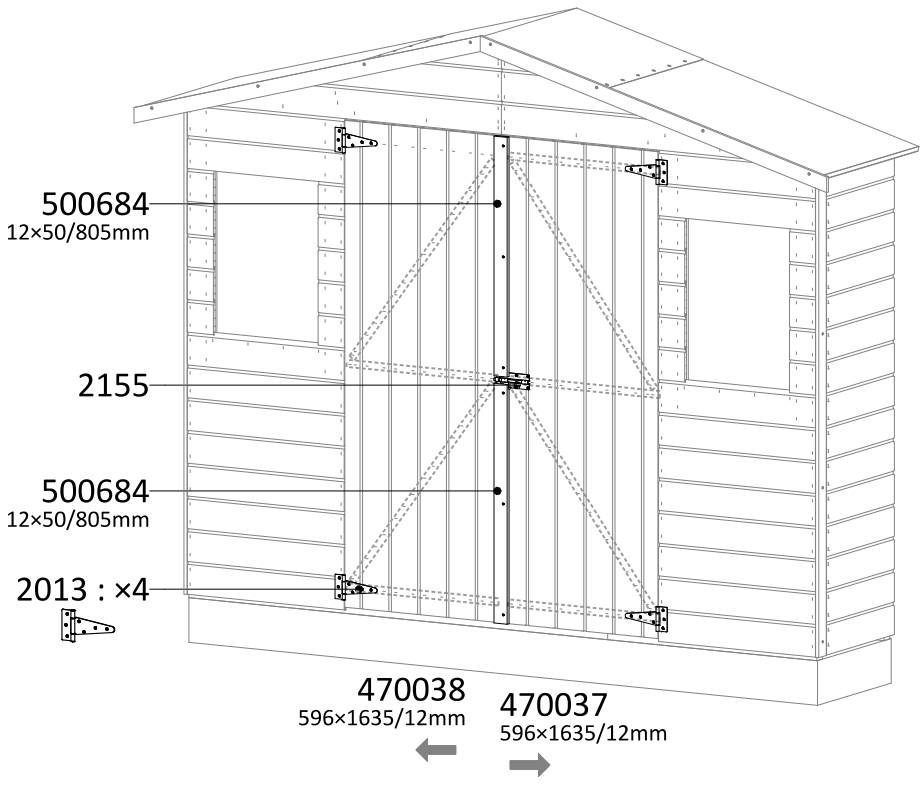

11



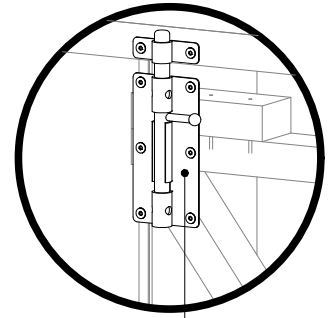
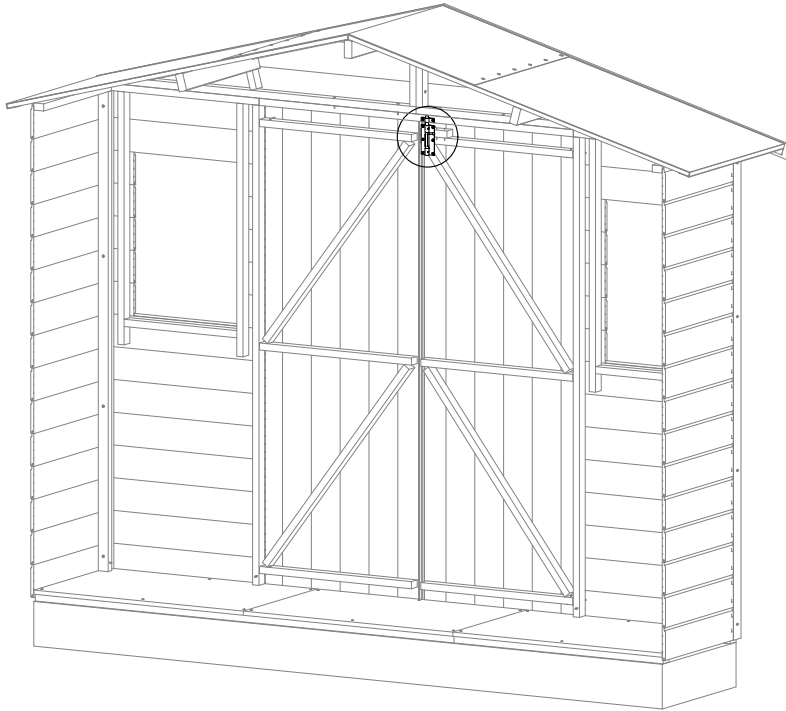

12



2155
+  3009 : x8
ø3,5x12



13

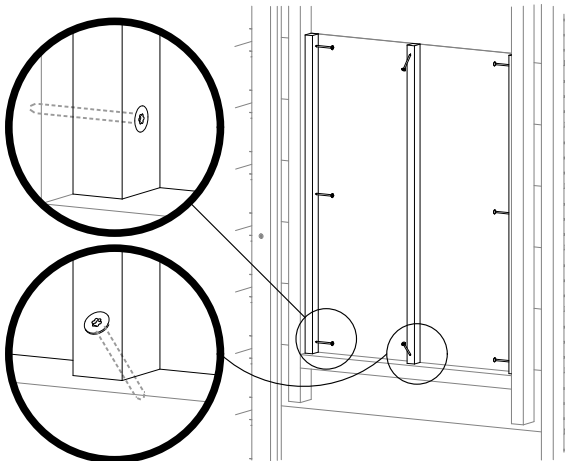
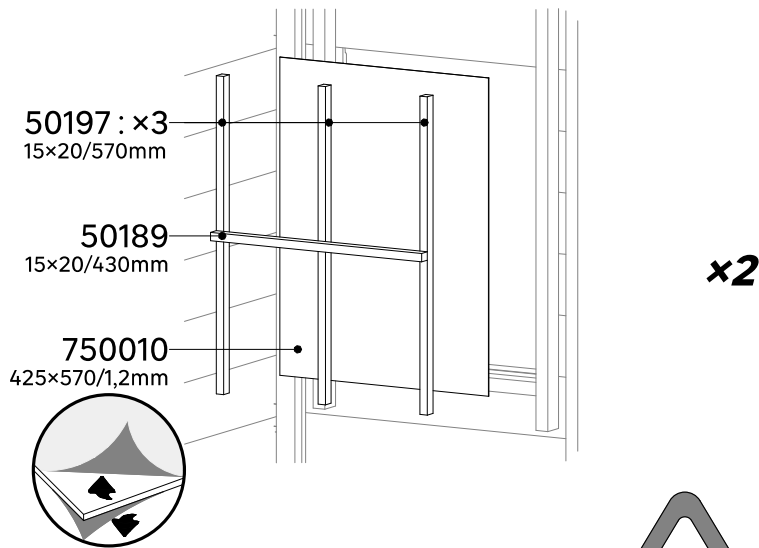
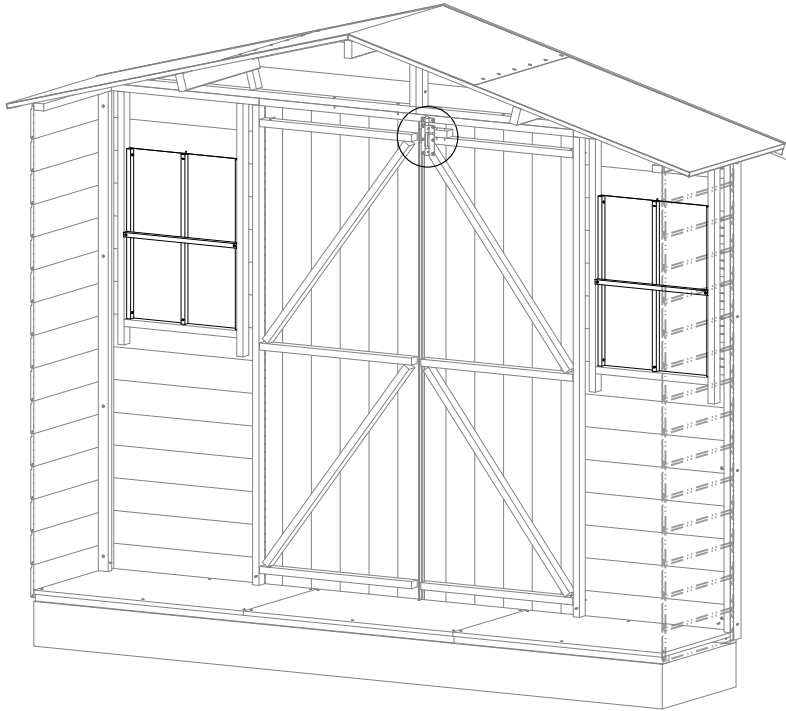

3014 : x8
Ø3,5x35

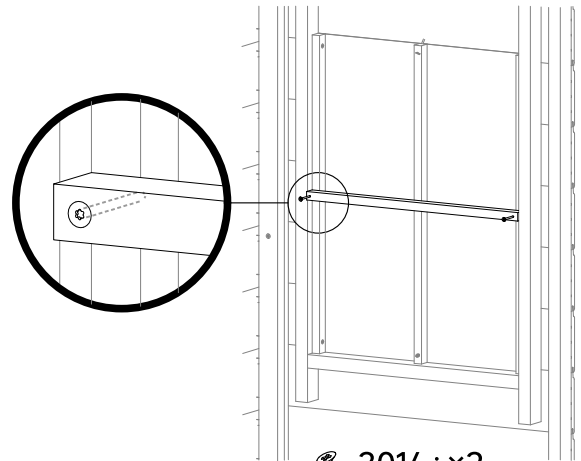

3014 : x2
Ø3,5x35



Silicone Mastic

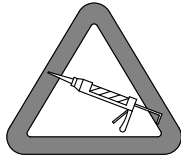

FR non incluse

ES non incluida

PT não incluído

IT non incluso

EL δεν περιλαμβάνεται

PL brak w zestawie

UA не входить у комплект

RO element neinclus

EN not included

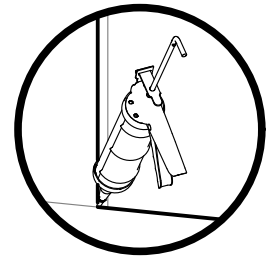
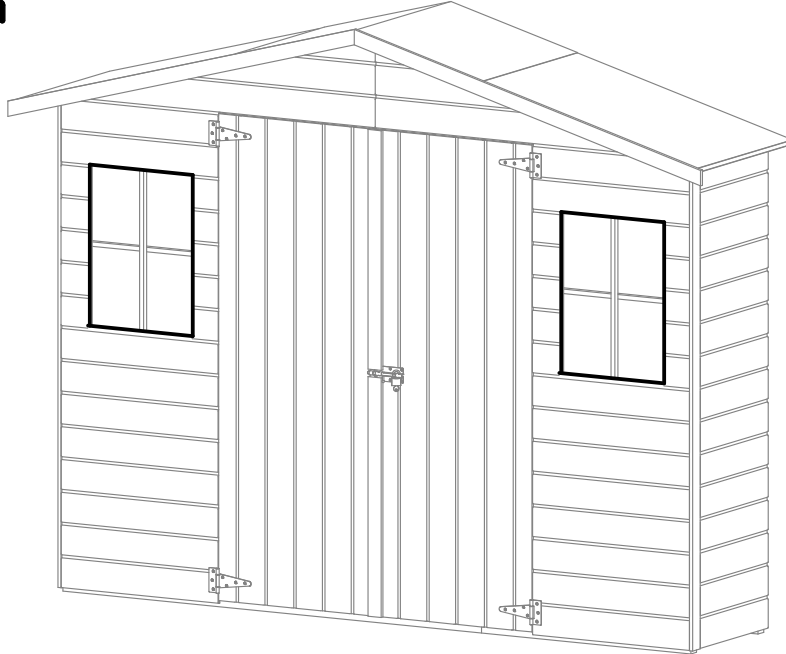

FR Ce produit est recyclable. S'il ne peut plus être utilisé, veuillez l'apporter dans un centre de recyclage de déchets.

ES Este producto es reciclable. Si ya no se puede usar, llévelo a un centro de reciclaje de residuos.

PT Este produto é reciclável. Se deixar de o utilizar, entregue-o num centro de reciclagem de resíduos.

IT Questo prodotto può essere riciclato. Se deve essere smaltito, portalo presso un centro di riciclaggio.

EL Αυτό το προϊόν είναι ανακυκλώσιμο. Εάν δεν μπορεί πλέον να χρησιμοποιηθεί, μεταφέρετε την σε κάποιο κέντρο ανακύκλωσης απορριμμάτων.

PL Ten produkt poddawany jest recyklingowi, kiedy przestaje być użyteczny należy dostarczyć go do punktu zbiórki odpadów.

UA Цей продукт може перероблятися. Якщо воно більше не є придатне для використання, здайте його в утилізаційний центр.

RO Aceast produs este reciclabil. Dacă nu mai poate fi folosit, vă rugăm să îl aduceți într-un centru de reciclare a deșeurilor.

EN This product is recyclable. If it cannot be used anymore, please take it to waste recycling centre.

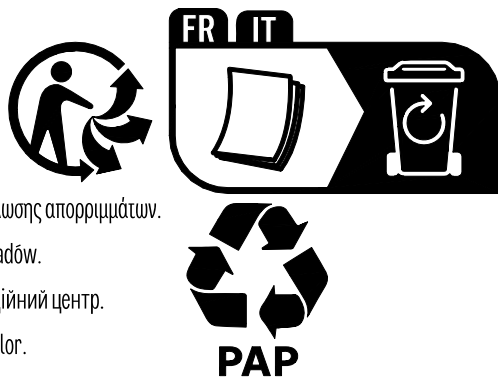

3
YEAR
Warranty

* **Bois garantie 3 ans / 3 años de garantía madera / Madeira garantia de 3 anos / Legno garanzia 3 anni / Ξύλο εγγύηση 3 ετών / Drewno gwarancja 3-letnia / Девянина гарантія 3 роки / Lemn garanție 3 ani / 3-year warranty wood**

1
YEAR
Warranty

** **Feutre bitumeux, quincaillerie et accessoires garantie 1 an / 1 año de garantía fieltro asfáltico, ferretería y accesorios / Feltros asfáltico, ferragens e acessórios garantia de 1 ano / Fieltro bituminoso, ferramenta e accessori garanzia 1 anni / Ασφαλτόπανο, ειδηρικά και αξεσουάρ εγγύηση 1 έτος / Filc bitumiczny, sprzęt i akcesoria gwarancja 1 rok / Бітумна покрівля, фурнітура та аксесуари гарантія 1 рік / Fieltro bituminoso, feronerie și accesorii garanție 1 ani / Bituminous felt, hardware, and accessories 1-year warranty**

EU ADEO : Adeo Services
135, rue Sadi Carnot- CS 00001 59790- RONCHIN- France
www.product-regulatory.adeoservices.com

Made in Belgium

Coller ici l'étiquette de garantie

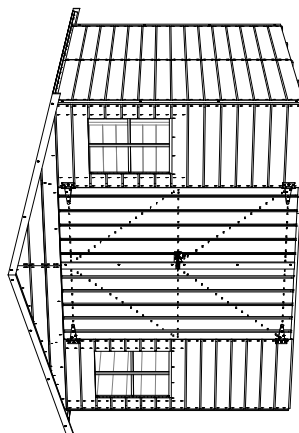

Denali

2,40x1,80m / 12mm

EAN : 3276007889758

MATRIX ID : 2025R09P11-0003

47521P055 - B-00439