 International Purchases	<b>GENERIC TECHNICAL SHEET</b>		Revision date
	<b>STEEL FOLDING CHAIR</b>		Prepared by <b>Letright</b>
<b>P 1/6</b>	<b>IDENTIFICATION</b>	International Quality Dept.	FOR <b>Adeo</b>

Version N° **Aug-18**

Issuing By: Crystal

date : 2018/9/4





**PRODUCTS IDENTIFICATION**

Supplier Reference(s) :	<b>735.000.001</b>	Supplier :	<b>LETRIGHT</b>
EAN 13 code	<b>3276000400578/3276000400561/3276000400554/3276000400547/3276000400530</b>		Jiande Luda Furniture Co.,Ltd
Designation :	<b>STEEL FOLDING CHAIR</b>	Factory(ies) / origin :	<b>ZHEJIANG JIANDE CITY</b>
Colors / finishing :	<b>COLOR:COCKTAIL/ AQUA/CACTUS/CREAM/DARK GREY; FINISHING:POWDER COATING</b>		
MDD :	<b>NATERIAL</b>	1st date on the market :	

**TCF CONTENT**

<input type="checkbox"/>	Technical sheet	<b>Q5</b>
<input type="checkbox"/>	Product conformity lab tests	<b>Q3</b>
<input type="checkbox"/>	Conformity declarations	<b>Q1/2</b>
<input type="checkbox"/>	REACH test report	<b>Q2</b>
<input type="checkbox"/>	Other test report	<b>Q3</b>
<input type="checkbox"/>	Exploded view	<b>Q6</b>
<input type="checkbox"/>	Assembly instruction	<b>Q8</b>
<input type="checkbox"/>	Maintenance instruction	<b>Q8</b>
<input type="checkbox"/>	Warranty leaflet	<b>Q8</b>
<input type="checkbox"/>	Technical drawings	<b>Q6</b>
<input type="checkbox"/>	Golden Sample	
<input type="checkbox"/>	Product Marking / CE marking	<b>Q8/Q3</b>
<input type="checkbox"/>	Shipping marks	<b>Q8</b>
<input type="checkbox"/>	Packaging Packing Process file	<b>Q7</b>
<input type="checkbox"/>	Palletization plan	<b>Q7</b>
<input type="checkbox"/>	Other packaging documents	<b>Q7</b>
<input type="checkbox"/>	Artworks	<b>Q8</b>
<input type="checkbox"/>		<b>Q7</b>
<input type="checkbox"/>	Packaging tests	<b>Q8</b>

**PHOTO (S)**

Photo	Atlas No.	EAN	Supplier Ref.	Color	Description
	847919	3276000400578	735.000.001	AQUA	NATERIAL FLORA ORIGAMI CHAIR FULL STEEL AQUA
	847920	3276000400561	735.000.001	COCKTAIL	NATERIAL FLORA ORIGAMI CHAIR FULL STEEL COCKTAIL
	847921	3276000400554	735.000.001	CACTUS	NATERIAL FLORA ORIGAMI CHAIR FULL STEEL CACTUS
	847922	3276000400547	735.000.001	CREAM	NATERIAL FLORA ORIGAMI CHAIR FULL STEEL CREAM
	847923	3276000400530	735.000.001	DARK GREY	NATERIAL FLORA ORIGAMI CHAIR FULL STEEL DARK GREY

	D (cm)	W (cm)	H (cm)	NW (kg)	Assembling type	FSC / PEFC	TFT	CE marking	Batch number on the product	Registered products	
Type 1	45.3	40.8	79.5	4.2	KIT <input type="checkbox"/> Assembled <input checked="" type="checkbox"/>	no	no	no	no	no	no
Type 2					KIT <input type="checkbox"/> Assembled <input type="checkbox"/>						
Type 3					KIT <input type="checkbox"/> Assembled <input type="checkbox"/>						
Type 4					KIT <input type="checkbox"/> Assembled <input type="checkbox"/>						
<b>t [+/-]</b>	+/-2%	+/-2%	+/-2%								

STEEL FOLDING CHAIR

PRODUCT COMPOSITION DETAILS

Code	Type of elements	QTY	Material		Covering / veneer / finishing	
			Type : for wooden parts don't forget to fill in the sheet 4	Characteristics / dimensions		
1	Back slat	2		STEEL		E-COATING
2	Seat slat	5		STEEL		E-COATING
3	Leg tube	2		STEEL		E-COATING
4	SEAT TUBE	1		STEEL		GALVANIZED IN WHITE
5	Nut	4		STEEL		GALVANIZED IN WHITE
6	SCREW	4		STEEL,M5X15		GALVANIZED IN WHITE
7	Seat cap	4		PLASTIC PP		WHITE
8	Leg cap	4		PLASTIC PP		WHITE

Exploded view / Numbered view (or photo)

Maxi loads on the Tops, shelves and extract

TECHNICAL DRAWING

735.000.001  
UNIT : MM

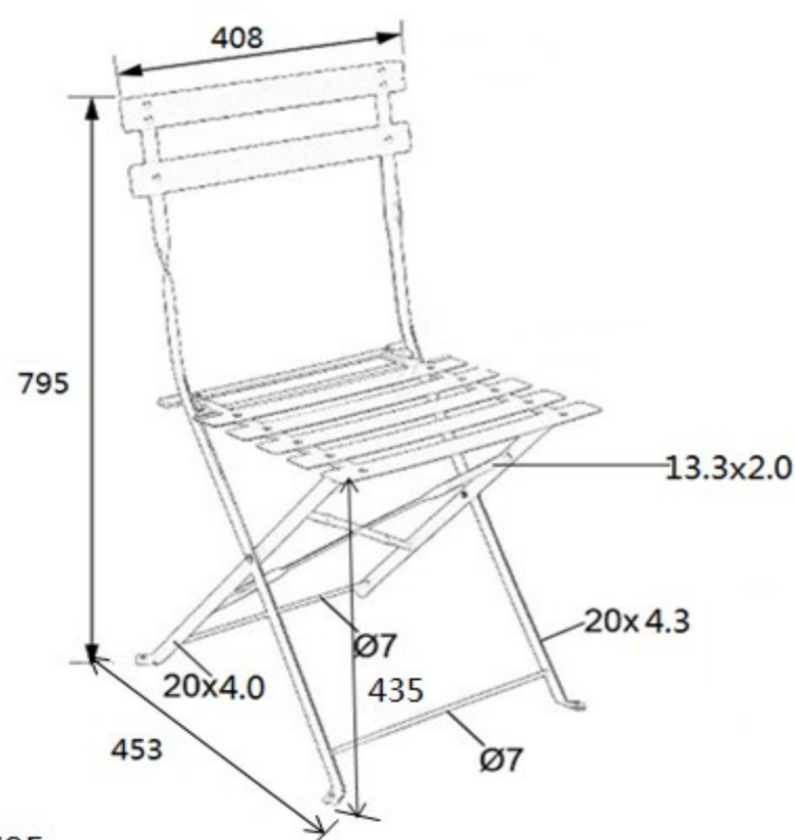

TOLERANCE: +/-2%  
SIZE:W408XD453XH795  
MATERIAL: STEEL POWDER COATING W/E - COATING

EXPLODED DRAWING

